



**TP CENTRAL ODISHA DISTRIBUTION LIMITED**  
(A Tata Power & Odisha Govt. joint venture)  
2nd Floor, IDCO Tower, Janpath Bhubaneswar, Odisha 751022

NIT No.: TPCODL/P&S/72/2020-21

Note: Following steps to be done before last date and time of payment of tender participation fee.

1. Eligible and Interested bidder to send email to TPCODL attaching duly signed and stamped letter on Bidder's letterhead, with following details, expressing their intend to bid against above tender:

- (a). Tender Enquiry number,
- (b). Name of authorized person
- (c). Contact number
- (d) e-mail id
- (e). Details of submission of Tender Participation Fee
- (f) GST Number

2. Non-Refundable Tender Participation Fee, as indicated in tender document, to be submitted in the form of Direct deposit in the following bank account and submit the receipt/details of online payment as mentioned in 1(e) above.

**Account Name: TP Central Odisha Distribution Limited**  
**Bank Name: SBI, IDCO Towers, Bhubaneswar**  
**Bank Account No.: 10835304915**  
**IFSC Code: SBIN0007891**

E-mail with necessary attachment of 1 and 2 above to be send to [vibhor.singh@tpcentralodisha.com](mailto:vibhor.singh@tpcentralodisha.com) , [vibhor.singh@tatapower-ddl.com](mailto:vibhor.singh@tatapower-ddl.com) with copy to [purchase@tpcentralodisha.com](mailto:purchase@tpcentralodisha.com) before "Last date and time for Payment of Tender Participation Fee".

3. Bids are to be submitted only through online e-procurement platform, ARIBA. Any other form of bid submission will not be accepted. **Link for bidding through ARIBA e-procurement platform will be mailed to bidder once Letter received as mentioned in point no 1 & 2 above.**

4. Refer Tender Document for other details.



**TP CENTRAL ODISHA DISTRIBUTION LIMITED**  
(A Tata Power & Odisha Govt. joint venture)  
2nd Floor, IDCO Tower, Janpath Bhubaneswar, Odisha 751022

NIT No.: TPCODL/P&S/72/2020-21

## **OPEN TENDER NOTIFICATION**

### **FOR**

**Rate Contract for 11kV and 1.1 kV associated works (Construction / Augmentation) all over TPCODL area for releasing new HT &LT connection & other misc. Distribution electrical works**

**Tender Enquiry No.: TPCODL/P&S/72/20-21**

**Due Date for Bid Submission: 31-Aug-2020 [15:00 Hrs.]**

**TP Central Odisha Distribution Limited  
(A TATA Power and Odisha Government Joint Venture)  
Procurement & Stores Department,  
2<sup>nd</sup> Floor, IDCO Towers, Janpath, Bhubaneswar – 751022**



**TP CENTRAL ODISHA DISTRIBUTION LIMITED**  
(A Tata Power & Odisha Govt. joint venture)  
2nd Floor, IDCO Tower, Janpath Bhubaneshwar, Odisha 751022

NIT No.: TPCODL/P&S/72/2020-21

**CONTENTS OF THE ENQUIRY**

**Contents**

1.0	Event Information.....	4
2.0	Evaluation Criteria .....	7
3.0	Submission of Bid Documents.....	7
4	Bid Opening & Evaluation process .....	11
5	Award Decision.....	12
6	Order of Preference/Contradiction.....	12
7	Post Award Contract Administration.....	12
8	Specification and standards .....	15
9	General Condition of Contract.....	15
10	Safety.....	16
	ANNEXURE I.....	17
	ANNEXURE II.....	188
	ANNEXURE III.....	189
	ANNEXURE IV.....	190
	ANNEXURE V.....	191
	ANNEXURE VI.....	192
	ANNEXURE VII.....	193
	ANNEXURE VIII.....	195
	ANNEXURE IX.....	196
	ANNEXURE X.....	209
	ANNEXURE XI.....	210



**TP CENTRAL ODISHA DISTRIBUTION LIMITED**  
(A Tata Power & Odisha Govt. joint venture)  
2nd Floor, IDCO Tower, Janpath Bhubaneswar, Odisha 751022

NIT No.: TPCODL/P&S/72/2020-21

## 1.0 Event Information

### 1.1. Scope of work

**Open Tenders** are invited from interested Bidders entering into a Rate Contract valid for 1 years for the following:

S. No.	Description	EMD Amount (Rs.)	Tender Fee* (Rs.)																																	
1.	Construction of new 11KV & 1.1KV Linking line, 11/0.433KV Substation with associated equipment for releasing power supply to new consumers & Misc. electrical activities.	5,00,000	5,000																																	
	<table border="1"><thead><tr><th>Lot Details</th><th>Circle Details</th><th>Division Details</th></tr></thead><tbody><tr><td>Lot-1</td><td>BBSR-I</td><td>BCDD-I &amp; BCDD-II</td></tr><tr><td>Lot-2</td><td>BBSR-I</td><td>BED &amp; NED</td></tr><tr><td>Lot-3</td><td>BBSR-II</td><td>BED &amp; NED</td></tr><tr><td>Lot-4</td><td>BBSR-II</td><td>KED &amp; PED</td></tr><tr><td>Lot-5</td><td>Cuttack</td><td>CDD-I &amp; CDD-II</td></tr><tr><td>Lot-6</td><td>Cuttack</td><td>CED &amp; SED</td></tr><tr><td>Lot-7</td><td>Cuttack / Dhenkanal</td><td>Cuttack -AED &amp; Dhenkanal -DED</td></tr><tr><td>Lot-8</td><td>Dhenkanal</td><td>TED / AED</td></tr><tr><td>Lot-9</td><td>Paradeep</td><td>KED-I &amp; KED-II</td></tr><tr><td>Lot-10</td><td>Paradeep</td><td>PED &amp; JED</td></tr></tbody></table>			Lot Details	Circle Details	Division Details	Lot-1	BBSR-I	BCDD-I & BCDD-II	Lot-2	BBSR-I	BED & NED	Lot-3	BBSR-II	BED & NED	Lot-4	BBSR-II	KED & PED	Lot-5	Cuttack	CDD-I & CDD-II	Lot-6	Cuttack	CED & SED	Lot-7	Cuttack / Dhenkanal	Cuttack -AED & Dhenkanal -DED	Lot-8	Dhenkanal	TED / AED	Lot-9	Paradeep	KED-I & KED-II	Lot-10	Paradeep	PED & JED
	Lot Details			Circle Details	Division Details																															
	Lot-1			BBSR-I	BCDD-I & BCDD-II																															
	Lot-2			BBSR-I	BED & NED																															
	Lot-3			BBSR-II	BED & NED																															
	Lot-4			BBSR-II	KED & PED																															
	Lot-5			Cuttack	CDD-I & CDD-II																															
	Lot-6			Cuttack	CED & SED																															
	Lot-7			Cuttack / Dhenkanal	Cuttack -AED & Dhenkanal -DED																															
	Lot-8			Dhenkanal	TED / AED																															
Lot-9	Paradeep	KED-I & KED-II																																		
Lot-10	Paradeep	PED & JED																																		

*\*inclusive of GST*

### 1.2. Availability of Tender Documents

Non-transferable tender documents may be purchased by interested eligible bidders from address given below, on submission of written application to the under mentioned and upon payment of non-refundable Tender Fee.

**Chief (Procurement & Stores)**

TP Central Odisha Distribution Limited  
2<sup>nd</sup> Floor, IDCO Towers, Janpath, Bhubaneswar – 751022

Tender documents may be downloaded by interested eligible bidders from TPCODL website [www.tpcentralodisha.com](http://www.tpcentralodisha.com) with effect from 5<sup>th</sup> Aug 2020. In the event of detailed tender documents are downloaded from TPCODL website, the Tender Fee shall be compulsorily submitted either online through NEFT/ RTGS or demand draft/ Banker's cheque drawn in favor of "TP Central Odisha Distribution Limited", payable at Bhubaneswar only. Any such bid submitted without this Fee shall be rejected.

Bidders are requested to visit TPCODL website [www.tpcentralodisha.com](http://www.tpcentralodisha.com) regularly for any modification/ clarification to the bid documents.





**TP CENTRAL ODISHA DISTRIBUTION LIMITED**  
(A Tata Power & Odisha Govt. joint venture)  
2nd Floor, IDCO Tower, Janpath Bhubaneshwar, Odisha 751022

NIT No.: TPCODL/P&S/72/2020-21

### 1.3. Calendar of Events

(a)	Date of sale/ availability of tender documents from TPCODL Website	06.07.2020 1000 Hours
(b)	Last date and time of Payment of Tender Fee	18.08.2020 1500 Hours
(c)	Last Date of receipt of pre-bid queries, if any	21.08.2020 1000 Hours
(d)	Last Date of Posting Consolidated replies to all the pre-bid queries as received	25.08.2020 1800 Hours
(e)	Last date and time of receipt of Bids	31.08.2020 1500 Hours
(f)	Date & Time of opening technical bids and EMD (Envelope-1 & 2)	31.08.2020 1700 Hours

**Note:** In the event of last date specified for submission of bids and date of opening of bids is declared as a closed holiday for TPCODL's office, the last date of submission of bids and date of opening of bids will be the day following working day at appointed times.

### 1.4 Mandatory documents required along with the Bid

- 1.4.1 EMD of requisite value and validity
- 1.4.2 Tender Fee in case the tender is downloaded from website
- 1.4.3 Requisite Documents for compliance to Qualification Criteria mentioned in Clause 1.7.
- 1.4.4 Drawing, Type Test details along with a sample of each item as specified at Annexure I (as applicable)
- 1.4.5 Duly signed and stamped 'Schedule of Deviations' as per Annexure III on bidder's letter head.
- 1.4.6 Duly signed and stamped 'Schedule of Commercial Specifications' as per Annexure IV on bidder's letter head.
- 1.4.7 Proper authorization letter/ Power of Attorney to sign the tender on the behalf of bidder.
- 1.4.8 Copy of PAN, GST, PF and ESI Registration (In case any of these documents is not available with the bidder, same to be explicitly mentioned in the 'Schedule of Deviations')

**Please note that in absence of any of the above documents, the bid submitted by a bidder shall be liable for rejection.**

### 1.5. Deviation from Tender

Normally, the deviations to tender terms are not admissible and the bids with deviation are liable for rejection. Hence, the bidders are advised to refrain from taking any deviations on this Tender. Still in case of any deviations, all such deviations shall be set out by the Bidders, clause by clause in the 'Annexure III - Schedule of Deviations' and same shall be submitted as a part of the Technical Bid.

### 1.6. Right of Acceptance/Rejection

Bids are liable for rejection in absence of following documents:

- i. EMD of requisite value and validity
- ii. Tender fee of requisite value



**TP CENTRAL ODISHA DISTRIBUTION LIMITED**  
(A Tata Power & Odisha Govt. joint venture)  
2nd Floor, IDCO Tower, Janpath Bhubaneshwar, Odisha 751022

NIT No.: TPCODL/P&S/72/2020-21

- iii. Price Bid as per the Price Schedule mentioned in Annexure I (BOQ)
- iv. Necessary documents against compliance to Qualification Requirements mentioned at Clause 1.7 of this Tender Document
- v. Filled in Schedule of Deviations as per Annexure III
- vi. Filled in Schedule of Commercial Specifications as per Annexure IV
- vii. Receipt of Bid within the due date and time

TPCODL reserves the right to accept/reject any or all the bids without assigning any reason thereof.

### 1.7 Qualification Criteria

- a) *The bidder should have an average annual turnover of Rs. 2 crore in last three financial years (FY 17-18, FY 18-19 and FY 19-20). Copy of audited Balance Sheet and P&L Account to be submitted in this regard.*
- b) *The bidder must have executed similar jobs for maintenance/ commissioning of 11 kV/33KV/ 1.1KV network in any utility/companies for a total value of Rs. 100 Lac or one single order of Rs. 20 lacs or two orders of Rs. 15 lacs each or three order of Rs 10 lac each during last 3 financial years.*

*Note: - In case the bidder has a previous association with TPCODL for similar products and services, the performance feedback for that bidder by TPCODL's User Group shall only be considered irrespective of performance certificates issued by any third organization.*

- c) *The bidder should have Valid Electrical Contractor License issued by Govt. of NCT of Delhi/Odisha to execute the electrical works in Odisha (valid for only ITC tenders). Copy of valid Electrical Contractor License issued by Govt. of NCT Delhi/Odisha needs to be submitted by bidder. In case bidder is not having this License, Bidder shall submit an undertaking that in case they are the successful bidder, same shall be obtained by them before award of contract by TPCODL.*
- d) *The bidder should have performance certificates from at least 2 reputed companies for similar or higher rating of work. The work against these issued certificates should be completed in last seven years from the date of bid submission.*
- e) *The bidder must have all statutory compliance like valid PAN no., ESI registration, EPF registration, GSTN etc. The bidder must submit the copy of all these registrations*

### 1.8. Marketing Integrity

We have a fair and competitive marketplace. The rules for bidders are outlined in the General Condition of Contracts. Bidders must agree to these rules prior to participating. In addition to other remedies available, TPCODL reserves the right to exclude a bidder from participating in future markets due to the bidder's violation of any of the rules or obligations contained in the General Condition of Contracts. A bidder who violates the market place rules or engages in behavior that disrupts the fair execution of the marketplace, may result in restriction of a bidder from further participation in the marketplace for a length of time, depending upon the seriousness of the violation. Examples of violations include, but are not limited to:

- Failure to honor prices submitted to the marketplace
- Breach of terms as published in TENDER/NIT



**TP CENTRAL ODISHA DISTRIBUTION LIMITED**  
(A Tata Power & Odisha Govt. joint venture)  
2nd Floor, IDCO Tower, Janpath Bhubaneswar, Odisha 751022

NIT No.: TPCODL/P&S/72/2020-21

### 1.9. Supplier Confidentiality

All information contained in this tender is confidential and shall not be disclosed, published or advertised in any manner without written authorization from TPCODL. This includes all bidding information submitted to TPCODL. All tender documents remain the property of TPCODL and all suppliers are required to return these documents to TPCODL upon request. Suppliers who do not honor these confidentiality provisions will be excluded from participating in future bidding events.

### 2.0 Evaluation Criteria

- The bids will be evaluated technically on the compliance to tender terms and conditions.
- The bids will be evaluated commercially on overall BOQ basis (all-inclusive lowest cost) for the complete tender as calculated in Schedule of Items [Annexure I].
- The bids will be evaluated on Safety Parameters as mentioned in Annexure-VIII. Bidders have to submit all the documents related to safety bid.
- Bidder has to mandatorily quote against each item of Schedule of Items [Annexure I]. Failing to do so, TPCODL may reject the bids.

**NOTE:** In case a new bidder is not registered with TPCODL, factory inspection and evaluation shall be carried out to ascertain bidder's manufacturing capability and quality procedures. However, TPCODL reserves the right to carry out factory inspection and evaluation for any bidder prior to technical qualification.

In case a bidder is found as Disqualified in the factory evaluation, their bid shall not be evaluated any further and shall be summarily rejected. The decision of TPCODL shall be final and binding on the bidder in this regard.

**2.1 Price Variation Clause:** The prices shall remain firm during the entire contract period.

### 3.0 Submission of Bid Documents

#### 3.1 Bid Submission

Bidders are requested to submit their offer in line with this Tender document through e-tendering process.

Please note all future correspondence regarding the tender, bid submission, bid submission date extension, etc. will happen only through TPCODL E-Tender system (Ariba).

All communication will be done strictly with the bidder who have done the above step to participate in the Tender.

Bids shall be submitted in 4 (four) parts:

**FIRST PART: "EMD"** as applicable shall be submitted. The EMD shall be valid for 210 days from the due date of bid submission in the form of Bank Guarantee / Bank Draft / Bankers Pay Order (issued from a Scheduled Bank) online NEFT/ RTGS transfer favoring 'TP Central Odisha Distribution Limited' payable at Bhubaneswar. The EMD has to be strictly in the format as mentioned in General Condition of Contract, failing which it shall not be accepted by TPCODL and the bid as submitted shall be liable for rejection. A separate non-refundable tender fee of stipulated amount also needs to be transferred online through NEFT/ RTGS in case the tender document is downloaded from our website.

TPCODL Bank Details for transferring Tender Fee and EMD is as below:

*Property of TPCODL – Not to be reproduced without prior written permission of TPCODL*



**TP CENTRAL ODISHA DISTRIBUTION LIMITED**  
(A Tata Power & Odisha Govt. joint venture)  
2nd Floor, IDCO Tower, Janpath Bhubaneswar, Odisha 751022

NIT No.: TPCODL/P&S/72/2020-21

**Account Name: TP CENTRAL ODISHA DISTRIBUTION LIMITED**  
**Bank Name: SBI, IDCO Towers, Bhubaneswar**  
**Bank Account No.: 10835304915**  
**IFSC Code: SBIN0007891**

**Note-** EMD is preferred in form of Bank Guarantee and to be delivered at the following address. However, in view of present situation if Bidder is finding it difficult to make and submit BG for EMD amount, they can do online transfer of EMD amount in the above mentioned Account and submit proof of the same as part of Bid Submission.

Please note that in such case, Tender Fee and EMD should be strictly 2 separate transactions.

Please note as return of EMD from Bank Account is non-standard practice the same may take more time than return of EMD BG.

**EMD Original Hard Copy shall be delivered at the following address in Envelope clearly indicating Tender Reference/ Enquiry Number, Name of Tender and Bidder Name**

**Chief (Procurement & Stores)**  
**TP Central Odisha Distribution Limited**  
**2<sup>nd</sup> Floor, IDCO Towers, Janapath, Bhubaneswar- 751022**

**SECOND PART: "TECHNICAL BID"** shall contain the following documents:

- a) Documentary evidence in support of qualifying criteria
- b) Technical literature/GTP/Type test report etc. (if applicable)
- c) Qualified manpower (if available)
- d) Testing facilities (if applicable)
- e) No Deviation Certificate as per the Annexure III – Schedule of Deviations
- f) Acceptance to Commercial Terms and Conditions viz. Delivery schedule/period, payment terms etc. as per the Annexure IV – Schedule of Commercial Specifications.
- g) Quality Assurance Plan/Inspection Test Plan for supply items (if applicable)

**The technical bid shall be properly indexed and is to be submitted through TPCODL E-tender System (Ariba) only. Hard Copy of Technical Bids need not be submitted**

**THIRD PART (Safety Bid):** Bidder shall mention the details as required in the safety bid form (As mentioned in annexure- IX). Bidder also has to submit the relevant documents for the same as required by TPCODL

**FOURTH PART: "PRICE BID"** shall contain only the price details and strictly in format as mentioned in Annexure I along with explicit break up of basic prices, Taxes & duties, Freight etc. In case any discrepancy is observed between the item description stated in Schedule of Items mentioned in the tender and the price bid submitted by the bidder, the item description as mentioned in the tender document (to the extent modified through Corrigendum issued if any) shall prevail.

**Price Bid is to be submitted in soft copy through TPCODL E-Tendering system (Ariba) only. Hard copy of Price Bid not be submitted**

The EMD in the form of Bank Draft / BG / Bankers Pay Order shall be submitted in original hard copy and then placed in sealed envelope which shall be clearly marked as below:

EMD



**TP CENTRAL ODISHA DISTRIBUTION LIMITED**  
(A Tata Power & Odisha Govt. joint venture)  
2nd Floor, IDCO Tower, Janpath Bhubaneshwar, Odisha 751022

NIT No.: TPCODL/P&S/72/2020-21

**“Rate Contract for 11kV and 1.1 kV associated works (Construction / Augmentation) all over TPCODL area for releasing new HT &LT connection & other Misc. Distribution electrical works”**

The Bid prepared by the Bidder, and all correspondence and documents relating to the Bid exchanged by the Bidder and the TPCODL, shall be written in the English Language. Any printed literature furnished by the Bidder may be written in another Language, provided that this literature is accompanied by an English translation, in which case, for purposes of interpretation of the Bid, the English translation shall govern.

**SIGNING OF BID DOCUMENTS:**

The bid must contain the name, residence and place of business of the person or persons making the bid and must be signed and sealed by the Bidder with his usual signature. The names of all persons signing should also be typed or printed below the signature.

The Bid being submitted must be signed by a person holding a Power of Attorney authorizing him to do so, certified copies of which shall be enclosed.

The Bid submitted on behalf of companies registered with the Indian Companies Act, for the time being in force, shall be signed by persons duly authorized to submit the Bid on behalf of the Company and shall be accompanied by certified true copies of the resolutions, extracts of Articles of Association, special or general Power of Attorney etc. to show clearly the title, authority and designation of persons signing the Bid on behalf of the Company. Satisfactory evidence of authority of the person signing on behalf of the Bidder shall be furnished with bid.

A bid by a person who affixes to his signature the word ‘President’, ‘Managing Director’, ‘Secretary’, ‘Agent’ or other designation without disclosing his principal will be rejected.

The Bidder’s name stated on the Proposal shall be the exact legal name of the firm.

**3.2 Contact Information**

All the bidders are requested to send their pre-bid queries (if any) against this tender through e-mail within the stipulated timelines. The consolidated reply to all the queries received shall be posted on TPCODL website by the stipulated timelines as detailed in calendar of events.

**Communication Details:**

Handling Executive for this Tender:

Name: Vibhor Kumar Singh  
Contact No.: 8130485135  
E-Mail ID: [vibhor.singh@tpcentralodisha.com](mailto:vibhor.singh@tpcentralodisha.com) / [vibhor.singh@tatapower-ddl.com](mailto:vibhor.singh@tatapower-ddl.com)

Senior General Manager (Material Procurement):

Name: Mr. Deba Prasad Dash  
Contact No.: 9438297571  
E-Mail ID: [purchase@cescoorissa.com](mailto:purchase@cescoorissa.com)

**3.3 Bid Prices**

Bidders shall quote for the entire Scope of Supply/ work with a break up of prices for individual items and Taxes & duties. The bidder shall complete the appropriate Price Schedules included herein, stating the Unit Price for each item & total price with taxes, duties & freight up to destination at various sites of TPCODL. The all-inclusive prices offered shall be inclusive of





**TP CENTRAL ODISHA DISTRIBUTION LIMITED**  
(A Tata Power & Odisha Govt. joint venture)  
2nd Floor, IDCO Tower, Janpath Bhubaneswar, Odisha 751022

NIT No.: TPCODL/P&S/72/2020-21

all costs as well as Duties, Taxes and Levies paid or payable during the execution of the supply work, breakup of price constituents.

**Applicable GST to be specified clearly.**

The quantity break up shown else-where other than Price Schedule is tentative. The bidder shall ascertain himself regarding material required for completeness of the entire work. Any items not indicated in the price schedule but which are required to complete the job as per the Technical Specifications/ Scope of Work/ SLA mentioned in the tender, shall be deemed to be included in prices quoted.

**3.4 Bid Currencies**

Prices shall be quoted in Indian Rupees Only.

**3.5 Period of Validity of Bids**

Bids shall remain valid for 180 days from the due date of submission of the bid.

Notwithstanding clause above, the TPCODL may solicit the Bidder's consent to an extension of the Period of Bid Validity. The request and responses thereto shall be made in writing.

RC Validity: - The validity of this rate contract shall be one year from the date of issuance.

**3.6 Alternative Bids**

Bidders shall submit Bids, which comply with the Bidding documents. Alternative bids will not be considered. The attention of Bidders is drawn to the provisions regarding the rejection of Bids in the terms and conditions, which are not substantially responsive to the requirements of the bidding documents.

**3.7 Modifications and Withdrawal of Bids**

The bidder is not allowed to modify or withdraw its bid after the Bid's submission. The EMD as submitted along with the bid shall be liable for forfeiture in such event.

**3.8 Earnest Money Deposit (EMD)**

The bidder shall furnish, as part of its bid, an EMD amounting as specified in the tender. The EMD is required to protect TPCODL against the risk of bidder's conduct which would warrant forfeiture.

The EMD shall be denominated in any of the following form:

- Banker's Cheque/ Demand Draft/ Pay order drawn in favor of TP Central Odisha Distribution Limited payable at Bhubaneswar.
- Online transfer of requisite amount through NEFT/ RTGS.
- Bank Guarantee valid for 210 days after due date of submission.

***The EMD shall be forfeited in case:***

a) The bidder withdraws its bid during the period of specified bid validity.

**Or**

b) The successful Bidder does not

- a) accept the Purchase Order, or
- b) furnish the required Performance Security Bank Guarantee



**TP CENTRAL ODISHA DISTRIBUTION LIMITED**  
(A Tata Power & Odisha Govt. joint venture)  
2nd Floor, IDCO Tower, Janpath Bhubaneswar, Odisha 751022

NIT No.: TPCODL/P&S/72/2020-21

### **3.9 Type Tests (if applicable)**

The type tests specified in TPCODL specifications should have been carried out within five years prior to the date of opening of technical bids and test reports are to be submitted along with the bids. If type tests carried out are not within the five years prior to the date of bidding, the bidder will arrange to carry out type tests specified, at his cost. The decision to accept/reject such bids rests with TPCODL

## **4 Bid Opening & Evaluation process**

### **4.1. Process to be confidential**

Information relating to the examination, clarification, evaluation and comparison of Bids and recommendations for the award of a contract shall not be disclosed to Bidders or any other persons not officially concerned with such process. Any effort by a Bidder to influence the TPCODL's processing of Bids or award decisions may result in rejection of the Bidder's Bid.

### **4.2. Technical Bid Opening**

Bids will be opened at TPCODL Office, Bhubaneswar. All tender bids shall be opened internally by TPCODL. Presence of any bidder will not be allowed during bid opening process. Technical bid must not contain any cost information whatsoever.

First the envelope marked "EMD" will be opened. Bids without EMD/cost of tender (if applicable) of required amount/ validity in prescribed format, shall be rejected.

Next, the technical bid of the bidders who have furnished the requisite EMD will be opened, one by one.

### **4.3. Preliminary Examination of Bids/Responsiveness**

TPCODL will examine the Bids to determine whether they are complete, whether any computational errors have been made, whether required sureties have been furnished, whether the documents have been properly signed, and whether the Bids are generally in order. TPCODL may ask for submission of original documents in order to verify the documents submitted in support of qualification criteria.

Arithmetical errors will be rectified on the following basis: If there is a discrepancy between the unit price and the total price per item that is obtained by multiplying the unit price and quantity, the unit price shall prevail and the total price per item will be corrected. If there is a discrepancy between the Total Amount and the sum of the total price per item, the sum of the total price per item shall prevail and the Total Amount will be corrected.

Prior to the detailed evaluation, TPCODL will determine the substantial responsiveness of each Bid to the Bidding Documents including production capability and acceptable quality of the Goods offered. A substantially responsive Bid is one, which conforms to all the terms and conditions of the Bidding Documents without material deviation.

Bid determined as not substantially responsive will be rejected by the TPCODL and may not subsequently be made responsive by the Bidder by correction of the non-conformity.

### **4.4. Techno Commercial Clarifications**

Bidders need to ensure that the bids submitted by them are complete in all respects. To assist in the examination, evaluation and comparison of Bids, TPCODL may, at its discretion, ask the Bidder for a clarification on its Bid for any deviations with respect to the TPCODL specifications and attempt will be made to bring all bids on a common footing. All responses



**TP CENTRAL ODISHA DISTRIBUTION LIMITED**  
(A Tata Power & Odisha Govt. joint venture)  
2nd Floor, IDCO Tower, Janpath Bhubaneshwar, Odisha 751022

NIT No.: TPCODL/P&S/72/2020-21

to requests for clarification shall be in writing and no change in the price or substance of the Bid shall be sought, offered or permitted owing to any clarifications sought by TPCODL.

#### **4.5. Price Bid Opening**

Price bids will be opened internally without the presence of any bidder representative. The EMD of the bidder withdrawing or substantially altering his offer at any stage after the technical bid opening will be forfeited at the sole discretion of TPCODL without any further correspondence in this regard.

#### **4.6. Reverse Auctions**

TPCODL reserves the right to conduct the reverse auction (instead of public opening of price bids) for the products/ services being asked for in the tender. The terms and conditions for such reverse auction events shall be as per the Acceptance Form attached as Annexure VI of this document. The bidders along with the tender document shall mandatorily submit a duly signed copy of the Acceptance Form attached as Annexure VI as a token of acceptance for the same.

#### **5 Award Decision**

TPCODL will award the contract to the successful bidder whose bid has been determined to be the lowest-evaluated responsive bid as per the Evaluation Criterion mentioned at Clause 2.0. The Cost for the said calculation shall be taken as the all-inclusive cost quoted by bidder in Annexure I (Schedule of Items) subject to any corrections required in line with Clause 3.2 above. The decision to place purchase order/LOI solely depends on TPCODL on the cost competitiveness across multiple lots, quality, delivery and bidder's capacity, in addition to other factors that TPCODL may deem relevant.

TPCODL reserves the rights to award contract to one or more bidders so as to meet the delivery requirement or nullify award decision without assigning any reason thereof.

In case any supplier is found unsatisfactory during delivery process, the award will be cancelled and TPCODL reserves right to award contract to other suppliers who are found fit.

#### **6 Order of Preference/Contradiction**

In case of contradiction in any part of various documents in tender, following shall prevail in order of preference:

1. Schedule of Items (Annexure I)
2. Post Award Contract Administration (Clause 7.0)
3. Submission of Bid Documents (Clause 3.0)
4. Scope of Work and SLA (Annexure VII)
5. Technical Specifications (Annexure II)
6. Acceptance Form for Participation in Reverse Auction (Annexure VI)
7. General Conditions of Contract (Annexure VIII)

#### **7 Post Award Contract Administration**

##### **7.1. Special Conditions of Contract**

- Rate contract shall be valid for a period of 1 years from the placement of Contract. Release Order (RO) shall be placed as per the requirement of TPCODL. Rate shall remain FIRM till the validity of Rate Contract.
- Business Associate (BA) shall submit applicable Performance Bank Guarantee as per GCC within 30 days of issuance of order. PBG applicable shall be 5% of Order Value.

*Property of TPCODL – Not to be reproduced without prior written permission of TPCODL*





**TP CENTRAL ODISHA DISTRIBUTION LIMITED**  
(A Tata Power & Odisha Govt. joint venture)  
2nd Floor, IDCO Tower, Janpath Bhubaneswar, Odisha 751022

NIT No.: TPCODL/P&S/72/2020-21

PBG submitted, shall be released after completion of applicable guarantee period plus one month.

- Any change in statutory taxes, duties and levies during the contract period shall be borne by TPCODL. However, in case of delay in work execution owing to reasons not attributable to TPCODL, any increase in total liability shall be passed on the Bidder, whereas any benefits arising owing to such statutory variation in taxes and duties shall be passed on TPCODL.
- Statutory Variations: Any changes in existing taxes/ Duties and levies, Introduction of new taxes and duties etc. during the period of the contract shall be paid at actuals to BA subject to BA shall submit the tax break up in details, however, where BA has quoted the all-inclusive prices and not shown the tax break-up, this clause will not be applicable. The date of issue of MDCC shall be used for this purpose.
- Quotation in all BOM items is mandatory, and bid shall be rejected if any line of found blank in un price bid.
- There will be no price escalation given to bidder after issue the RO even if there is delayed the project due to ROW permission.
- Quotation in all BOM items is mandatory, and bid shall be rejected if any line of found blank in un price bid.
- In case any additional material is to be asked to supply after finalization of scope of work in the detailed Engineering, the Extra price and the extension of delivery time (if applicable) as the case may be mutually agreed between TPCODL and Successful Bidder
- **Warranty period:** 18 months from Handing over.
- All other terms and conditions of TPCODL General Conditions of Contract shall be applicable.

**Terms of Payment:**

70% on account payment against the actual executed value certified by EIC of TPCODL in running bill on pro-rate basis. Documents to be provided with invoice/bill: Joint measurement sheet/material verification sheet duly verified by EIC.

Balance 30 % payment of the actual executed order value shall be paid after handing over of the Complete system, including clearance of IHI, compliances of final punch point and after reconciliation of material & adjustment of payments, based on the service entry sheet approved by EIC.

The payment shall be released within 45 days from the date of submission of certified bills/ invoices.

**7.2 Drawing Submission and Approval**

The relevant drawings and GTPs need to be submitted within two weeks of receipt of firm purchase order by the successful bidder to TPCODL for approval. In case, re-submission of drawings is required on request of TPCODL, same needs to be submitted back to TPCODL within 5 days of such request.

**7.3 Delivery Timelines**

1. Release Orders shall be placed against the awarded Rate Contract by TPCODL as and when the requirements arise.



**TP CENTRAL ODISHA DISTRIBUTION LIMITED**  
(A Tata Power & Odisha Govt. joint venture)  
2nd Floor, IDCO Tower, Janpath Bhubaneshwar, Odisha 751022

NIT No.: TPCODL/P&S/72/2020-21

2. Scope and nature of work for individual RO varies from "Providing supply to a single consumer through a DP mounted sub-station" to "Electrification of large areas involving setting up of electrical distribution networks". The completion period of individual RO varies according to the scope and nature of work. Completion periods (in calendar days) for various categories of activities involved in such issued RO, are detailed hereunder.
3. For each issued RO the following will be the guidelines of completion period: -
  - a. Installation/Refurbishment of complete PMSS/Plinth Mounted SS with any rating of transformer/augmentation of DT, including HT/LT line extension up to five pole till consumer premises.: 2 nos. outages and 15 days.  
  
Installation of new 11KV overhead line with bare conductor /HT ABC: Up to 500 circuit meters till consumer premises - 15days. For every 500 circuit meters thereafter - 15 additional days.  
  
Refurbishment/Re-string of Conductor of old 11KV overhead line with bare conductor /HT ABC: Up to 1000 circuit meters with replacement of 5 Poles till consumer premises - 15 days with two outages.
  - b. Laying of HT/LT U/G cable, Feeder pillar installation in trench/ Trenchless duct including making of trench/trenchless duct till consumer premises:  
Up to 500 circuit meters - 30 days. For every 500 circuit meters thereafter - 15 additional days.
  - c. Installation of new LT overhead line with bare conductor /LT ABC till consumer premises: Up to 500 circuit meters - 15 days with two outages. For every 500 circuit meters thereafter - 15 additional days.  
  
Refurbishment/Re-string of Conductor of old LT overhead line with bare conductor /LT ABC with: Up to 1000 circuit meters with replacement of 5 Poles - 7 days with two outages.
  - d. Installation of the 3 /4 RMU Indoor/ outdoor including cable connection - Indoor type RMU - 7 days. Outdoor type RMU - 15 days.
  - e. In case any RO covers two or more categories of activities mentioned herein-above, the longest completion period amongst all the categories of activities covered thereunder, shall be treated as completion period for the RO.
  - f. TPCODL Team will do the quality inspection of all the BA Supplied Material against the RO. TPCODL Team will reject the material if quality & standard of the material found not satisfactory. Penalty of 30% of the total RO order will be imposed for the inferior quality.



**TP CENTRAL ODISHA DISTRIBUTION LIMITED**  
(A Tata Power & Odisha Govt. joint venture)  
2nd Floor, IDCO Tower, Janpath Bhubaneswar, Odisha 751022

NIT No.: TPCODL/P&S/72/2020-21

- g. It is however to be noted that in case of any urgency, TPCODL reserves the right to reduce the above mentioned timelines further as per the requirement. The decision of TPCODL in this regard shall be final and binding on the bidder.

#### **7.4 Warranty Period**

As per SCC

#### **7.5 Payment Terms**

As per SCC

#### **7.6 Climate Change**

Significant quantities of waste are generated during the execution of project and an integrated approach for effective handling, storage, transportation and disposal of the same shall be adopted. This would ensure the minimization of environmental and social impact in order to combat the climate change. Please refer attached Environment Policy and Sustainability Policy, Annexure-XI for more details.

#### **7.7 Ethics**

TPCODL is an ethical organization and as a policy TPCODL lays emphasis on ethical practices across its entire domain. Bidder should ensure that they should abide by all the ethical norms and in no form either directly or indirectly be involved in unethical practice.

TPCODL work practices are governed by the Tata Code of Conduct which emphasizes on the following:

- We shall select our suppliers and service providers fairly and transparently.
- We seek to work with suppliers and service providers who can demonstrate that they share similar values. We expect them to adopt ethical standards comparable to our own.
- Our suppliers and service providers shall represent our company only with duly authorized written permission from our company. They are expected to abide by the Code in their interactions with, and on behalf of us, including respecting the confidentiality of information shared with them.
- We shall ensure that any gifts or hospitality received from, or given to, our suppliers or service providers comply with our company's gifts and hospitality policy.
- We respect our obligations on the use of third party intellectual property and data.

Bidder is advised to refer Tata Code of Conduct (TCOC) attached at Annexure X for more information.

Any ethical concerns with respect to this tender can be reported to the following e-mail ID:

[purchase@cescoorissa.com](mailto:purchase@cescoorissa.com) / [pkjain@tatapower.com](mailto:pkjain@tatapower.com)

#### **8 Specification and standards**

As per Annexure II

#### **9 General Condition of Contract**

Any condition not mentioned above shall be applicable as per GCC attached along with this tender.



**TP CENTRAL ODISHA DISTRIBUTION LIMITED**  
(A Tata Power & Odisha Govt. joint venture)  
2nd Floor, IDCO Tower, Janpath Bhubaneshwar, Odisha 751022

NIT No.: TPCODL/P&S/72/2020-21

### **10 Safety**

All jobs are this tender have to be executed strictly in compliance to the Safety terms and Conditions of TP Central Odisha Distribution Limited. Please refer attached Safety terms and conditions, Annexure-IX, for details. Violation of Safety norms will result in Penalty as mentioned in the above document.

CONFIDENTIAL



**TP CENTRAL ODISHA DISTRIBUTION LIMITED**  
(A Tata Power & Odisha Govt. joint venture)  
2nd Floor, IDCO Tower, Janpath Bhubaneshwar, Odisha 751022

NIT No.: TPCODL/P&S/72/2020-21

**ANNEXURE I**

**Lot-1- Schedule for Items for BBSR-I – BCDD-I & BCDD-II Division**

Sr No	Item Description	Qty	Unit	HSN /SAC Code	Unit Ex-Work Price (Rs./Unit)	GST (Rs/Unit)	Other Taxes and Duties (Rs/Unit)	Freight & Insurance Charges (Rs/Unit)	GST on Freight & Insurance Charges (Rs/Unit)	All Inclusive Unit Rate (Rs.)	Total All Inclusive Value (Rs.)
1	Supply of 150x150mm RS Joist Pole ( 11mtr )	4	No								
2	Supply of 150x150mm RS Joist Pole ( 13mtr )	2	No.								
3	9 mtr. long 116X100 RS Joist Pole(23.0Kg per Meter)	2	No.								
4	9 mtr. long 300 Kg. PSC Pole	3	No.								
5	Supply of 11 KV V cross Arm (10.2 K.g. each )	48	No.								
6	Supply of Top bracket 75x40mm MS channel ( 1.3kg each)for 11KV	48	No.								
7	Supply of Back Clamp for V cross Arm 1.70Kg each For 11KV pole	144	Pair								
8	Supply of 11 K.V.GI Pin	144	No.								
9	Supply of 11 K.V. Pin Insulator polymer	144	No.								
10	Supply of 11 K.V. H.W. Fitting (B & S)	86	No.								
11	Supply of 11 K.V. polymer Insulator (B & S) Double Disc 70KN	518	No.								



**TP CENTRAL ODISHA DISTRIBUTION LIMITED**  
(A Tata Power & Odisha Govt. joint venture)  
2nd Floor, IDCO Tower, Janpath Bhubaneshwar, Odisha 751022

NIT No.: TPCODL/P&S/72/2020-21

12	Supply of H.T. Stay set (Complete ) for 11KV	29	Set								
13	Supply of H.T. Stay Insulator for 11KV pole	29	No.								
14	Supply of H.T. Stay clamp (1.95 K.g./ Pair ) for 11KV Pole	29	Pair								
15	Supply of 7/10 SWG Stay Wire 10kg /stay for 11KV Pole	288	K.g.								
16	Supply of Earthing of Support for 11KV Pole ( Coil Type )	48	No.								
17	Supply of Red Oxide paint (1.2Kg per 11KV Pole)	57.6	Ltr								
18	Supply of Aluminium Paint ( 1.2Kg per 11KV Pole)	57.6	Ltr								
19	Supply of Black Paint ( 0.3Kg per 11KV Pole)	14.4	Ltr								
20	Supply of GI barbed wire anticlimbing device 2 Kg. Per support for 11KV Pole	96	Kg								
21	Supply of 100 x 50 x 6 mm MS channel for 4nos Cut point ( 52Kg per Cutpoint)	748.8	Kg								
22	Supply of 75 x 40 x 6 mm MS channel for 11KV DP	196.8	Kg								
23	Supply of 50X50X6mm Cross Bressing Angel for of 11KV DP	196.8	Kg								
24	Supply of GI Pipe for Earthing 40 Dia Medium gage 3 mtrs. Long	100	No.								
25	40x6mm GI Flat for neutral	400	Kg								
26	Supply of 3 1/2 x 35mm <sup>2</sup> PVC Cable for 25KVA TFR.	150	Mtr								



**TP CENTRAL ODISHA DISTRIBUTION LIMITED**  
(A Tata Power & Odisha Govt. joint venture)  
2nd Floor, IDCO Tower, Janpath Bhubaneshwar, Odisha 751022

NIT No.: TPCODL/P&S/72/2020-21

27	Supply of Ms Nut , Bolt & Washer of different sizes	42.4	Kg								
28	Supply of 11KV AB Switch 3 Pole (200 Amp.)	20	Set								
29	Supply of 11KV AB Switch 3 Pole (400 Amp.)	2.4	Set								
30	Supply of 11KV HG Fuse 3 Pole (400 Amp.)	20	No.								
31	Supply of 11 KV L.A. 12KV-10KA	60	No.								
32	Supply of Pressure Channel 100 x 50 x 6mm MS channel each 2.8 mtr. Long( 9.2 K.g. per mtr.)X2 Nos ( Per Transformer H pole - 51.52Kg)	1030.4	Kg								
33	Supply of Transformer mounting channel 100 x 50 x 6mm MS channel each 2.8 mtr. Long( 9.2 K.g. per mtr.)X2 Nos (Per Transformer H pole -51.52Kg)	1030.4	Kg								
34	Supply of MS Angle for mounting AB Swith & HG .Channel size 75x40x6 -2.8 mtr.long, 4 nos.(6.8K.g. per mtr.)-76.16Kg per H-Pole	1523.2	Kg								
35	Supply of MS Angle for Cantilever channel for supporting AB Switch arm, Channel size 75x40x6-1 mtr. Long, 2 nos.(6.8 K.g. per mtr.) - 13.6Kg per H -Pole	272	Kg								
36	Supply of MS Angle for Cantilever channel for supporting HG Fuse . Channel size 50 x 50 x 6 mm MS	180	Kg								



**TP CENTRAL ODISHA DISTRIBUTION LIMITED**  
(A Tata Power & Odisha Govt. joint venture)  
2nd Floor, IDCO Tower, Janpath Bhubaneshwar, Odisha 751022

NIT No.: TPCODL/P&S/72/2020-21

	Angel (1.0 mtrs. Long 2 nos.)4.5K.g. per mtr. (9Kg per TRF H Pole)										
37	Supply of MS Angle for Cantilever arrangement for AB Switch & HG Fuse. Channel size 50 x 50 x 6 -2 mtr .each 2 nos.(4.5 K.g. per mtr.) ( 18K.g. per TRF H pole)	360	Kg								
38	Supply of MS Angle for Transformer belting. Angle size 50 x 50 x 6 mm - 2.8 mtr. Long 2 nos.(4.5 K.g. per mtr.) with side angel ( Total 7 mtr.)(31.5Kg per TRF H Pole)	630	Kg								
39	Supply of MS Angle for mounting LT distribution Box 50 x 50 x 6 mm MS Angel -2.5 mtrs. each Long 2 nos.( 4.5 Kg per mtr.)(22.5Kg per TRF H Pole)	450	Kg								
40	Supply of L.T. Distribution box including Kit Kat fuse with MCCB for 25KVA S/S ( As pre CESU specification)	10	No.								
41	Supply of 3 1/2C x 35mm <sup>2</sup> PVC Cable for 25KVA TFR.	150	Mtr								
42	Supply of L.T. Distribution box with MCCB, Aluminium Busbar for 2bay with Kit Kat fuse for 100KVA S/S	4	No.								
43	Supply of 3 1/2C x 150mm <sup>2</sup> PVC Cable for 100 KVA TFR	6	Mtr								







**TP CENTRAL ODISHA DISTRIBUTION LIMITED**  
(A Tata Power & Odisha Govt. joint venture)  
2nd Floor, IDCO Tower, Janpath Bhubaneshwar, Odisha 751022

NIT No.: TPCODL/P&S/72/2020-21

61	Supply of 1.1KV, 4C, 240Sqmm for XLPE Cable, AL,ARM	50	Mtr.																
62	Supply of 1.1KV, 4C, 300Sqmm for XLPE Cable,AL,ARM	50	No.																
63	Supply of 11KV, 3C, 95Sqmm for XLPE Cable,AL,ARM	50	No.																
64	Supply of 11KV, 3C, 120Sqmm for XLPE Cable,AL,ARM	50	No.																
65	Supply of 11KV, 3C, 185Sqmm for XLPE Cable,AL,ARM	50	No.																
66	Supply of 11KV, 3C, 300Sqmm for XLPE Cable,AL,ARM	50	No.																
67	Supply of 11KV, 3C, 400Sqmm for XLPE Cable,AL,ARM	50	No.																
68	Supply of 11KV 3C, 400Sqmm Straight thru Jointing KIT, HS for XLPE Cable for Indoor	2	No.																
69	Supply of 11KV, 3C, 300Sqmm Straight thru Jointing KIT ,HS for XLPE Cable	2	No.																
70	Supply of 11KV , 3C, 120Sqmm Straight thru Jointing KIT ,HS for XLPE Cable	2	No.																
71	Supply of 11KV , 3C, 95Sqmm Straight thru Jointing KIT ,HS for XLPE Cable	2	No.																
72	Supply of 1.1KV 4C 300Sqmm Straight thru Jointing KIT,HS for XLPE Cable	2	No.																
73	Supply of 1.1KV 4C 150Sqmm Straight thru Jointing KIT,HS for XLPE Cable	2	No.																



**TP CENTRAL ODISHA DISTRIBUTION LIMITED**  
(A Tata Power & Odisha Govt. joint venture)  
2nd Floor, IDCO Tower, Janpath Bhubaneshwar, Odisha 751022

NIT No.: TPCODL/P&S/72/2020-21

74	Supply of 1.1KV 4C 95Sqmm Straight thru Jointing KIT,HS for XLPE Cable	2	No.																
75	Supply 3CX 300Sqmm,11KV Indoor Termination Kit	2	No.																
76	Supply 3CX 400Sqmm,11KV Indoor Termination Kit	2	No.																
77	Supply 3CX 120Sqmm,11KV Indoor Termination Kit	2	No.																
78	Supply 3CX 185Sqmm,11KV Indoor Termination Kit	2	No.																
79	Supply 3CX 95Sqmm,11KV Indoor Termination Kit	2	No.																
80	Supply 3CX 400Sqmm,11KV Outdoor Termination Kit	2	No.																
81	Supply 3CX 300Sqmm,11KV Outdoor Termination Kit	2	No.																
82	Supply 3CX 185Sqmm,11KV Outdoor Termination Kit	2	No.																
83	Supply 3CX 120Sqmm,11KV Outdoor Termination Kit	2	No.																
84	3P 4 W 11 KV CT PT Combined Metering Unit Class of Accuracy 0.5 with CTR 20/5 A, with burden 15VA, PT with Burden 50VA	4	No																
85	Supply of 4C X 4Sqmm AL PVC Service cable un Arm for releasing 1PH	36720	Mtr																
86	Supply 3.5C * 35Sqmm LT PVC Cable Un armoured	12240	Mtr																
87	Supply 3.5C * 50qmm LT PVC Cable Un armoured	4896	Mtr																



**TP CENTRAL ODISHA DISTRIBUTION LIMITED**  
(A Tata Power & Odisha Govt. joint venture)  
2nd Floor, IDCO Tower, Janpath Bhubaneshwar, Odisha 751022

NIT No.: TPCODL/P&S/72/2020-21

88	Supply 3.5C * 95Sqmm LT PVC Cable Un armoured	4896	Mtr								
89	Concreting of support C.C - 1:4:8 using 40mm BHG metal size - 5'x2'x2' = 20CFT = 0.570Cum Padding 900x600x150mm = 0.081 0.651Cum	88	No's								
90	Coupling of support section 15"x15" ( 3.9Cft) height 2'-6" ( 1' - 6" above G.L & 1' - 0" below G.L ) in C.C 1:2:4 using 12mm BHG metal & curing for 5 days	88	Nos								
91	Erection of RS Joist pole(150x150mm) 13mtr.	88	No.								
92	Erection of RS Joist pole(150x150mm) 11mtr.	88	No.								
93	Erection of 9mtr. long 300kg PSC pole	40	No.								
94	Installation of 11 KV V cross Arm (10.2 Kg each )	48	No.								
95	Installation of Top bracket 75x40mm MS channel ( 1.3kg each)/	48	No.								
96	Installation of Back Clamp for V cross Arm 1.70Kg each	48	Pair								
97	Installation of 11 K.V.GI Pin	144	No.								
98	Installation of 11 K.V. Pin Insulator	144	No.								
99	Installation of 11 K.V. DISC Insulator (B & S) Double Disc 70KN With H/W Fitting	86	No.								
100	Fixing of Stay Set (Complete)	29	No								



**TP CENTRAL ODISHA DISTRIBUTION LIMITED**  
(A Tata Power & Odisha Govt. joint venture)  
2nd Floor, IDCO Tower, Janpath Bhubaneshwar, Odisha 751022

NIT No.: TPCODL/P&S/72/2020-21

101	Fixing of stay set with 0.5Cum cement concrete foundation 1:3:6 size ( 900mmx600mmx900mm) using 40mm BHG metal with all labor and material except stay set , stay wire , stay insulator .	29	No.								
102	Installation of Earthing of Support ( Coil Type )	88	No.								
103	Installation of Earth Pit, Charcoal, Salt etc. including construction of earthing chamber (Size: 2'x2') and RCC slab cover	100	No.								
104	Stringing of 80-100mm <sup>2</sup> AAAC	2.4	KM								
105	Painting of RS Joist Pole with fittings 2 coats of Al paint over a coat of red oxide primer including all Tools & Tackle	88	No.								
106	Installation, Testing and Commissioning of 11/0.4kV, 25kVA 3-Phase Distribution Transformer on existing structure as per TP Central Orissa Distribution Ltd. specification including loading, unloading, shifting/transportation from Division store to site /tent. Scope of work includes, jumpering/connection at HT and LT side , including minor site modification as per the TPCODL Standard Excluding Earthing	10	EA								



**TP CENTRAL ODISHA DISTRIBUTION LIMITED**  
(A Tata Power & Odisha Govt. joint venture)  
2nd Floor, IDCO Tower, Janpath Bhubaneshwar, Odisha 751022

NIT No.: TPCODL/P&S/72/2020-21

107	Installation, Testing and Commissioning of 11/0.4kV, 63kVA 3-Phase Distribution Transformer on existing structure as per TP Central Orissa Distribution Ltd. specification including loading, unloading, shifting/transportation from Division store to site /tent. Scope of work includes, jumpering/connection at HT and LT side , including minor site modification as per the TPCODL Standard Excluding Earthing	4	EA								
108	Installation, Testing and Commissioning of 11/0.4kV, 100kVA 3-Phase Distribution Transformer on existing structure as per TP Central Orissa Distribution Ltd. specification including loading, unloading, shifting/transportation from Division store to site /tent. Scope of work includes, jumpering/connection at HT and LT side , including minor site modification as per the TPCODL Standard Excluding Earthing	4	EA								
109	Installation, Testing and Commissioning of 11/0.4kV, 250kVA 3-Phase Distribution Transformer on existing structure as per TP Central Orissa	2	EA								



**TP CENTRAL ODISHA DISTRIBUTION LIMITED**  
(A Tata Power & Odisha Govt. joint venture)  
2nd Floor, IDCO Tower, Janpath Bhubaneshwar, Odisha 751022

NIT No.: TPCODL/P&S/72/2020-21

	Distribution Ltd. specification including loading, unloading, shifting/transportation from site /tent. Scope of work includes earthing, jumpering/connection at HT and LT side as per the TPCODL Standard										
110	Installation of Outdoor Type Distribution Box with 40A MCCB with O/G for 11/0.4kV,25kVA Three Phase Transformer as per TP Central Orissa Distribution Ltd. specification	10	No								
111	Installation of Outdoor Type Distribution Box with 100A MCCB with O/G for 11/0.4kV,63kVA Three Phase Transformer as per TP Central Orissa Distribution Ltd. specification	4	No								
112	Installation of Outdoor Type Distribution Box (BOX DIST.WITH 160A 35KA TP MCCB 6 O/G) for 100KVA TRF	4	No								
113	Installation testing and commissioning of LT ACB 400 Amps with enclosure for 11/0.4KV 250KVA Threephase Transformer	2	No								
114	Installation of Outdoor Type Distribution Box(BOX DIST.WITH 500A 50KA TP MCCB 5 O/G) with MCCB for 11/0.4kV,250kVA Three Phase Transformer on existing	2	No								







**TP CENTRAL ODISHA DISTRIBUTION LIMITED**  
(A Tata Power & Odisha Govt. joint venture)  
2nd Floor, IDCO Tower, Janpath Bhubaneshwar, Odisha 751022

NIT No.: TPCODL/P&S/72/2020-21

129	Dismantling of MS Channel from 11KV Pole / DP	40	Kg								
130	Dismantling of 55mm <sup>2</sup> AAA Conductor	0.2	KM								
131	Dismantling of 80mm <sup>2</sup> AAA Conductor	0.2	KM								
132	Dismantling of 100mm <sup>2</sup> AAA Conductor	0.2	KM								
133	Sundries for survey tree cutting, small size nut bolt, Aluminium Binding wire / tape & Danger Board 4 Nos. etc. Line length of 1KM	2.4	LS								
134	Sundries for survey tree cutting, small size nut bolt, Aluminium. Binding wire / tape & Danger Board 4 Nos. etc. Substation upto 250KVA	20	LS								
135	Installation of Dead end clamp on LT Pole	24	No.								
136	Installation of Suspension clamp with I-Hook on LT Pole	72	No.								
137	Installation of Strain fittings on LT pole	19	No.								
138	Installation of Guy grip Dead end for LT Pole	19	No.								
139	Installation of Earthing Coil TO POLE	17	No.								
140	Laying / stringing of AB Cable( 3 x50 + 1x35mm <sup>2</sup> )	2400	Mtr.								
141	Laying / Stringing of AB Cable( 3 x35 + 1x25mm <sup>2</sup> )	2400	Mtr.								



**TP CENTRAL ODISHA DISTRIBUTION LIMITED**  
 (A Tata Power & Odisha Govt. joint venture)  
 2nd Floor, IDCO Tower, Janpath Bhubaneshwar, Odisha 751022

NIT No.: TPCODL/P&S/72/2020-21

142	Laying / Stringing of AB Cable( 3 x50 + 1x35mm <sup>2</sup> +1X16mm <sup>2</sup> )	2400	Mtr.								
143	Laying / Stringing of AB Cable( 3 x95 + 1x70mm <sup>2</sup> +1X16mm <sup>2</sup> )	2400	Mtr.								
144	Laying of Service cable 4sqmm x 2C	2	Mtr.								
145	Laying of 1.1KV 3.5C, 35Sqmm AL XLPE Cable	12240	Mtr.								
146	Laying of 1.1KV 3.5C, 150SqmmAL XLPE Cable	4896	Mtr.								
147	Laying of 1.1KV 4C, 240Sqmm AL XLPE Cable	4896	Mtr.								
148	Laying of 1.1KV 3.5C, 300Sqmm AL XLPE Cable	50	Mtr.								
149	Laying & EXCAVATION (1M Depth * 0.875M Width) of 11kV Armoured XLPE AL Cable 3CX95 sqmm/ 3CX120 sqmm in S/Sth. Trench/Tray as per TP Central Orissa Distribution Ltd. specification including testing of cable. Scope of work exclude fixing of Tray.BA will provide support during joint making by OEM of joint kit,no seperate payment will be paid to BA for this support by BA	50	Mtr.								
150	Laying & Excavation (1M Depth * 0.875M) of 11kV Armoured XLPE AL Cable 3CX400/ 3X300 sqmm in S/Sth. Trench/Tray as per TP Central Orissa Distribution Ltd.	50	Mtr.								



**TP CENTRAL ODISHA DISTRIBUTION LIMITED**  
(A Tata Power & Odisha Govt. joint venture)  
2nd Floor, IDCO Tower, Janpath Bhubaneshwar, Odisha 751022

NIT No.: TPCODL/P&S/72/2020-21

	specification including testing of cable. Scope of work exclude fixing of Tray.BA will provide support during joint making by OEM of joint kit,no seperate payment will be paid to BA for this support by BA										
151	Jointing of I/D or O/D of HT (11KV ) UGC & icluding all related work and Approved Jointer	2	No.								
152	Indoor / outdoor Termination of 11 kV Armoured XLPE, AL Cable 3CX95 sqmm,120Sqmm, 185Sqmm, 300SQMM, 400SQMM including consumable	2	EA								
153	Construction of 11KV RMU Plinth with Brick, Mortar, 12 mm cement plaster and painting with enamel paint.	2	EA								
154	Installation, Testing and Commissioning of 11kV 3-way Ring Main Unit on existing structure/foundation as per TP Central Orissa Distribution Ltd. specification including grouting, loading, unloading, shifting/transportation from site/tent. Scope of work includes pipe earthing, jumpering/connection and modification to foundation at Site	2	EA								



**TP CENTRAL ODISHA DISTRIBUTION LIMITED**  
(A Tata Power & Odisha Govt. joint venture)  
2nd Floor, IDCO Tower, Janpath Bhubaneshwar, Odisha 751022

NIT No.: TPCODL/P&S/72/2020-21

155	Installation, Testing and Commissioning of 1.1kV Feeder pillar with new structure/foundation as per TP Central Orissa Distribution Ltd. specification including grouting, loading, unloading, shifting/transportation from site/tent. Scope of work includes Pipe earthing, jumpering/connection and modification to foundation at Site	2	EA								
156	Extension of one LBS in existing 11KV RMU structure specification including grouting, loading, unloading, shifting/transportation from site/tent. Scope of work includes earthing, jumpering/connection and construction / modification of foundation	2	EA								
157	Supply & Installation of HT Danger Board as per TP Central Orissa Distribution Ltd. specification	400	No.								
158	Transportation of various items from TPCODL store/site to other site or vice versa in TPCODL operational area - Truck with labours as required (price per Km). Scope of work also include loading and unloading of materials including heavy items like HT	100	MT/KM								



**TP CENTRAL ODISHA DISTRIBUTION LIMITED**  
(A Tata Power & Odisha Govt. joint venture)  
2nd Floor, IDCO Tower, Janpath Bhubaneshwar, Odisha 751022

NIT No.: TPCODL/P&S/72/2020-21

	Panel, Transformer, Cable Drum, LT Board where loading, unloading is to be done with crane and crane will be paid separately .Transport charges upto 50KM Per Metric Ton@Rs 16/KM										
159	Installation of Fire Extinguisher (5kG DCP) by means of proper hooks clamps etc. as required including providing of grouting material (cement etc.) and painting of hooks/clamps. Scope exclude supply of hook/clamp	40	No.								
160	Painting of Pole In Black & Yellow Strips/Zebra as per TP Central Orissa Distribution Ltd. specifications and indexing/numbering of Poles as per GIS format, scope also include site survey for GIS indexing and supply of ISI Marked good quality paint. (this item shall be paid for old poles only and where this not mentioned in scope)	88	No.								
161	Installation of 11KV CTPT Unit with all connection & Earthing as per TPCODL Drawing	5	No								
<b>Total All Inclusive Price</b>											



**TP CENTRAL ODISHA DISTRIBUTION LIMITED**  
(A Tata Power & Odisha Govt. joint venture)  
2nd Floor, IDCO Tower, Janpath Bhubaneshwar, Odisha 751022

NIT No.: TPCODL/P&S/72/2020-21

**Lot-2- Schedule for Items for BBSR –I BED & BBSR -I NED Division**

Sr No	Item Description	Qty	Unit	HSN /SAC Code	Unit Ex-Work Price (Rs./Unit)	GST (Rs/Unit)	Other Taxes and Duties (Rs/Unit)	Freight & Insurance Charges (Rs/Unit)	GST on Freight & Insurance Charges (Rs/Unit)	All Inclusive Unit Rate (Rs.)	Total All Inclusive Value (Rs.)
1	Supply of 150x150mm RS Joist Pole ( 11mtr )	4	No								
2	Supply of 150x150mm RS Joist Pole ( 13mtr )	2	No.								
3	9 mtr. long 116X100 RS Joist Pole(23.0Kg per Meter)	2	No.								
4	9 mtr. long 300 Kg. PSC Pole	3	No.								
5	Supply of 11 KV V cross Arm (10.2 K.g. each )	48	No.								
6	Supply of Top bracket 75x40mm MS channel ( 1.3kg each)for 11KV	48	No.								
7	Supply of Back Clamp for V cross Arm 1.70Kg each For 11KV pole	144	Pair								
8	Supply of 11 K.V.GI Pin	144	No.								
9	Supply of 11 K.V. Pin Insulator polymer	144	No.								
10	Supply of 11 K.V. H.W. Fitting (B & S)	86	No.								
11	Supply of 11 K.V. polymer Insulator (B & S) Double Disc 70KN	518	No.								
12	Supply of H.T. Stay set (Complete ) for 11KV	29	Set								



**TP CENTRAL ODISHA DISTRIBUTION LIMITED**  
(A Tata Power & Odisha Govt. joint venture)  
2nd Floor, IDCO Tower, Janpath Bhubaneshwar, Odisha 751022

NIT No.: TPCODL/P&S/72/2020-21

13	Supply of H.T. Stay Insulator for 11KV pole	29	No.								
14	Supply of H.T. Stay clamp (1.95 K.g./ Pair ) for 11KV Pole	29	Pair								
15	Supply of 7/10 SWG Stay Wire 10kg /stay for 11KV Pole	288	K.g.								
16	Supply of Earthing of Support for 11KV Pole ( Coil Type )	48	No.								
17	Supply of Red Oxide paint (1.2Kg per 11KV Pole)	57.6	Ltr								
18	Supply of Aluminium Paint ( 1.2Kg per 11KV Pole)	57.6	Ltr								
19	Supply of Black Paint ( 0.3Kg per 11KV Pole)	14.4	Ltr								
20	Supply of GI barbed wire anticlimbing device 2 Kg. Per support for 11KV Pole	96	Kg								
21	Supply of 100 x 50 x 6 mm MS channel for 4nos Cut point ( 52Kg per Cutpoint)	748.8	Kg								
22	Supply of 75 x 40 x 6 mm MS channel for 11KV DP	196.8	Kg								
23	Supply of 50X50X6mm Cross Bressing Angel for of 11KV DP	196.8	Kg								
24	Supply of GI Pipe for Earthing 40 Dia Medium gage 3 mtrs. Long	100	No.								
25	40x6mm GI Flat for neutral	400	Kg								
26	Supply of 3 1/2 x 35mm <sup>2</sup> PVC Cable for 25KVA TFR.	150	Mtr								
27	Supply of Ms Nut , Bolt & Washer of different sizes	42.4	Kg								



**TP CENTRAL ODISHA DISTRIBUTION LIMITED**  
(A Tata Power & Odisha Govt. joint venture)  
2nd Floor, IDCO Tower, Janpath Bhubaneshwar, Odisha 751022

NIT No.: TPCODL/P&S/72/2020-21

28	Supply of 11KV AB Switch 3 Pole (200 Amp.)	20	Set								
29	Supply of 11KV AB Switch 3 Pole (400 Amp.)	2.4	Set								
30	Supply of 11KV HG Fuse 3 Pole (400 Amp.)	20	No.								
31	Supply of 11 KV L.A. 12KV-10KA	60	No.								
32	Supply of Pressure Channel 100 x 50 x 6mm MS channel each 2.8 mtr. Long( 9.2 K.g. per mtr.)X2 Nos ( Per Transformer H pole - 51.52Kg)	1030.4	Kg								
33	Supply of Transformer mounting channel 100 x 50 x 6mm MS channel each 2.8 mtr. Long( 9.2 K.g. per mtr.)X2 Nos (Per Transformer H pole -51.52Kg)	1030.4	Kg								
34	Supply of MS Angle for mounting AB Swith & HG .Channel size 75x40x6 -2.8 mtr.long, 4 nos.(6.8K.g. per mtr.)-76.16Kg per H-Pole	1523.2	Kg								
35	Supply of MS Angle for Cantilever channel for supporting AB Switch arm, Channel size 75x40x6-1 mtr. Long, 2 nos.(6.8 K.g. per mtr.) - 13.6Kg per H -Pole	272	Kg								
36	Supply of MS Angle for Cantilever channel for supporting HG Fuse . Channel size 50 x 50 x 6 mm MS Angel (1.0 mtrs. Long 2	180	Kg								





**TP CENTRAL ODISHA DISTRIBUTION LIMITED**  
(A Tata Power & Odisha Govt. joint venture)  
2nd Floor, IDCO Tower, Janpath Bhubaneshwar, Odisha 751022

NIT No.: TPCODL/P&S/72/2020-21

	nos.)4.5K.g. per mtr. (9Kg per TRF H Pole)										
37	Supply of MS Angle for Cantilever arrangement for AB Switch & HG Fuse. Channel size 50 x 50 x 6 -2 mtr .each 2 nos.(4.5 K.g. per mtr.) ( 18K.g. per TRF H pole)	360	Kg								
38	Supply of MS Angle for Transformer belting. Angle size 50 x 50 x 6 mm - 2.8 mtr. Long 2 nos.(4.5 K.g. per mtr.) with side angel ( Total 7 mtr.)(31.5Kg per TRF H Pole)	630	Kg								
39	Supply of MS Angle for mounting LT distribution Box 50 x 50 x 6 mm MS Angel -2.5 mtrs. each Long 2 nos.( 4.5 Kg per mtr.)(22.5Kg per TRF H Pole)	450	Kg								
40	Supply of L.T. Distribution box including Kit Kat fuse with MCCB for 25KVA S/S ( As pre CESU specification)	10	No.								
41	Supply of 3 1/2C x 35mm <sup>2</sup> PVC Cable for 25KVA TFR.	150	Mtr								
42	Supply of L.T. Distribution box with MCCB, Aluminium Busbar for 2bay with Kit Kat fuse for 100KVA S/S	4	No.								
43	Supply of 3 1/2C x 150mm <sup>2</sup> PVC Cable for 100 KVA TFR	6	Mtr								
44	Supply of L.T. Distribution box with MCCB, Aluminium Busbar for	2	No.								









**TP CENTRAL ODISHA DISTRIBUTION LIMITED**  
(A Tata Power & Odisha Govt. joint venture)  
2nd Floor, IDCO Tower, Janpath Bhubaneshwar, Odisha 751022

NIT No.: TPCODL/P&S/72/2020-21

88	Supply 3.5C * 95Sqmm LT PVC Cable Un armoured	4896	Mtr								
89	Concreting of support C.C - 1:4:8 using 40mm BHG metal size - 5'x2'x2' = 20CFT = 0.570Cum Padding 900x600x150mm = 0.081 0.651Cum	88	No's								
90	Coupling of support section 15"x15" ( 3.9Cft) height 2'-6" ( 1' - 6" above G.L & 1' - 0" below G.L ) in C.C 1:2:4 using 12mm BHG metal & curing for 5 days	88	Nos								
91	Erection of RS Joist pole(150x150mm) 13mtr.	88	No.								
92	Erection of RS Joist pole(150x150mm) 11mtr.	88	No.								
93	Erection of 9mtr. long 300kg PSC pole	40	No.								
94	Installation of 11 KV V cross Arm (10.2 Kg each )	48	No.								
95	Installation of Top bracket 75x40mm MS channel ( 1.3kg each)/	48	No.								
96	Installation of Back Clamp for V cross Arm 1.70Kg each	48	Pair								
97	Installation of 11 K.V.GI Pin	144	No.								
98	Installation of 11 K.V. Pin Insulator	144	No.								
99	Installation of 11 K.V. DISC Insulator (B & S) Double Disc 70KN With H/W Fitting	86	No.								
100	Fixing of Stay Set (Complete)	29	No								



**TP CENTRAL ODISHA DISTRIBUTION LIMITED**  
(A Tata Power & Odisha Govt. joint venture)  
2nd Floor, IDCO Tower, Janpath Bhubaneshwar, Odisha 751022

NIT No.: TPCODL/P&S/72/2020-21

101	Fixing of stay set with 0.5Cum cement concrete foundation 1:3:6 size ( 900mmx600mmx900mm) using 40mm BHG metal with all labor and material except stay set , stay wire , stay insulator .	29	No.								
102	Installation of Earthing of Support ( Coil Type )	88	No.								
103	Installation of Earth Pit, Charcoal, Salt etc. including construction of earthing chamber (Size: 2'x2') and RCC slab cover	100	No.								
104	Stringing of 80-100mm <sup>2</sup> AAAC	2.4	KM								
105	Painting of RS Joist Pole with fittings 2 coats of Al paint over a coat of red oxide primer including all Tools & Tackle	88	No.								
106	Installation, Testing and Commissioning of 11/0.4kV, 25kVA 3-Phase Distribution Transformer on existing structure as per TP Central Orissa Distribution Ltd. specification including loading, unloading, shifting/transportation from Division store to site /tent. Scope of work includes, jumpering/connection at HT and LT side , including minor site modification as per the TPCODL Standard Excluding Earthing	10	EA								



**TP CENTRAL ODISHA DISTRIBUTION LIMITED**  
(A Tata Power & Odisha Govt. joint venture)  
2nd Floor, IDCO Tower, Janpath Bhubaneshwar, Odisha 751022

NIT No.: TPCODL/P&S/72/2020-21

107	Installation, Testing and Commissioning of 11/0.4kV, 63kVA 3-Phase Distribution Transformer on existing structure as per TP Central Orissa Distribution Ltd. specification including loading, unloading, shifting/transportation from Division store to site /tent. Scope of work includes, jumpering/connection at HT and LT side , including minor site modification as per the TPCODL Standard Excluding Earthing	4	EA								
108	Installation, Testing and Commissioning of 11/0.4kV, 100kVA 3-Phase Distribution Transformer on existing structure as per TP Central Orissa Distribution Ltd. specification including loading, unloading, shifting/transportation from Division store to site /tent. Scope of work includes, jumpering/connection at HT and LT side , including minor site modification as per the TPCODL Standard Excluding Earthing	4	EA								
109	Installation, Testing and Commissioning of 11/0.4kV, 250kVA 3-Phase Distribution Transformer on existing structure as per TP Central Orissa	2	EA								



**TP CENTRAL ODISHA DISTRIBUTION LIMITED**  
(A Tata Power & Odisha Govt. joint venture)  
2nd Floor, IDCO Tower, Janpath Bhubaneshwar, Odisha 751022

NIT No.: TPCODL/P&S/72/2020-21

	Distribution Ltd. specification including loading, unloading, shifting/transportation from site /tent. Scope of work includes earthing, jumpering/connection at HT and LT side as per the TPCODL Standard										
110	Installation of Outdoor Type Distribution Box with 40A MCCB with O/G for 11/0.4kV,25kVA Three Phase Transformer as per TP Central Orissa Distribution Ltd. specification	10	No								
111	Installation of Outdoor Type Distribution Box with 100A MCCB with O/G for 11/0.4kV,63kVA Three Phase Transformer as per TP Central Orissa Distribution Ltd. specification	4	No								
112	Installation of Outdoor Type Distribution Box (BOX DIST.WITH 160A 35KA TP MCCB 6 O/G) for 100KVA TRF	4	No								
113	Installation testing and commissioning of LT ACB 400 Amps with enclosure for 11/0.4KV 250KVA Threephase Transformer	2	No								
114	Installation of Outdoor Type Distribution Box(BOX DIST.WITH 500A 50KA TP MCCB 5 O/G) with MCCB for 11/0.4kV,250kVA Three Phase Transformer on existing	2	No								







**TP CENTRAL ODISHA DISTRIBUTION LIMITED**  
(A Tata Power & Odisha Govt. joint venture)  
2nd Floor, IDCO Tower, Janpath Bhubaneshwar, Odisha 751022

NIT No.: TPCODL/P&S/72/2020-21

129	Dismantling of MS Channel from 11KV Pole / DP	40	Kg								
130	Dismantling of 55mm <sup>2</sup> AAA Conductor	0.2	KM								
131	Dismantling of 80mm <sup>2</sup> AAA Conductor	0.2	KM								
132	Dismantling of 100mm <sup>2</sup> AAA Conductor	0.2	KM								
133	Sundries for survey tree cutting, small size nut bolt, Aluminium Binding wire / tape & Danger Board 4 Nos. etc. Line length of 1KM	2.4	LS								
134	Sundries for survey tree cutting, small size nut bolt, Aluminium. Binding wire / tape & Danger Board 4 Nos. etc. Substation upto 250KVA	20	LS								
135	Installation of Dead end clamp on LT Pole	24	No.								
136	Installation of Suspension clamp with I-Hook on LT Pole	72	No.								
137	Installation of Strain fittings on LT pole	19	No.								
138	Installation of Guy grip Dead end for LT Pole	19	No.								
139	Installation of Earthing Coil TO POLE	17	No.								
140	Laying / stringing of AB Cable( 3 x50 + 1x35mm <sup>2</sup> )	2400	Mtr.								
141	Laying / Stringing of AB Cable( 3 x35 + 1x25mm <sup>2</sup> )	2400	Mtr.								



**TP CENTRAL ODISHA DISTRIBUTION LIMITED**  
(A Tata Power & Odisha Govt. joint venture)  
2nd Floor, IDCO Tower, Janpath Bhubaneshwar, Odisha 751022

NIT No.: TPCODL/P&S/72/2020-21

142	Laying / Stringing of AB Cable( 3 x50 + 1x35mm <sup>2</sup> +1X16mm <sup>2</sup> )	2400	Mtr.								
143	Laying / Stringing of AB Cable( 3 x95 + 1x70mm <sup>2</sup> +1X16mm <sup>2</sup> )	2400	Mtr.								
144	Laying of Service cable 4sqmm x 2C	2	Mtr.								
145	Laying of 1.1KV 3.5C, 35Sqmm AL XLPE Cable	12240	Mtr.								
146	Laying of 1.1KV 3.5C, 150SqmmAL XLPE Cable	4896	Mtr.								
147	Laying of 1.1KV 4C, 240Sqmm AL XLPE Cable	4896	Mtr.								
148	Laying of 1.1KV 3.5C, 300Sqmm AL XLPE Cable	50	Mtr.								
149	Laying & EXCAVATION (1M Depth * 0.875M Width) of 11kV Armoured XLPE AL Cable 3CX95 sqmm/ 3CX120 sqmm in S/Sth. Trench/Tray as per TP Central Orissa Distribution Ltd. specification including testing of cable. Scope of work exclude fixing of Tray.BA will provide support during joint making by OEM of joint kit,no seperate payment will be paid to BA for this support by BA	50	Mtr.								
150	Laying & Excavation (1M Depth * 0.875M) of 11kV Armoured XLPE AL Cable 3CX400/ 3X300 sqmm in S/Sth. Trench/Tray as per TP Central Orissa Distribution Ltd.	50	Mtr.								



**TP CENTRAL ODISHA DISTRIBUTION LIMITED**  
(A Tata Power & Odisha Govt. joint venture)  
2nd Floor, IDCO Tower, Janpath Bhubaneshwar, Odisha 751022

NIT No.: TPCODL/P&S/72/2020-21

	specification including testing of cable. Scope of work exclude fixing of Tray.BA will provide support during joint making by OEM of joint kit,no seperate payment will be paid to BA for this support by BA										
151	Jointing of I/D or O/D of HT (11KV ) UGC & including all related work and Approved Jointer	2	No.								
152	Indoor / outdoor Termination of 11 kV Armoured XLPE, AL Cable 3CX95 sqmm,120Sqmm, 185Sqmm, 300SQMM, 400SQMM including consumable	2	EA								
153	Construction of 11KV RMU Plinth with Brick, Mortar, 12 mm cement plaster and painting with enamel paint.	2	EA								
154	Installation, Testing and Commissioning of 11kV 3-way Ring Main Unit on existing structure/foundation as per TP Central Orissa Distribution Ltd. specification including grouting, loading, unloading, shifting/transportation from site/tent. Scope of work includes pipe earthing, jumpering/connection and modification to foundation at Site	2	EA								



**TP CENTRAL ODISHA DISTRIBUTION LIMITED**  
(A Tata Power & Odisha Govt. joint venture)  
2nd Floor, IDCO Tower, Janpath Bhubaneshwar, Odisha 751022

NIT No.: TPCODL/P&S/72/2020-21

155	Installation, Testing and Commissioning of 1.1kV Feeder pillar with new structure/foundation as per TP Central Orissa Distribution Ltd. specification including grouting, loading, unloading, shifting/transportation from site/tent. Scope of work includes Pipe earthing, jumpering/connection and modification to foundation at Site	2	EA								
156	Extension of one LBS in existing 11KV RMU structure specification including grouting, loading, unloading, shifting/transportation from site/tent. Scope of work includes earthing, jumpering/connection and construction / modification of foundation	2	EA								
157	Supply & Installation of HT Danger Board as per TP Central Orissa Distribution Ltd. specification	400	No.								
158	Transportation of various items from TPCODL store/site to other site or vice versa in TPCODL operational area - Truck with labours as required (price per Km). Scope of work also include loading and unloading of materials including heavy items like HT	100	MT/KM								



**TP CENTRAL ODISHA DISTRIBUTION LIMITED**  
(A Tata Power & Odisha Govt. joint venture)  
2nd Floor, IDCO Tower, Janpath Bhubaneshwar, Odisha 751022

NIT No.: TPCODL/P&S/72/2020-21

	Panel, Transformer, Cable Drum, LT Board where loading, unloading is to be done with crane and crane will be paid separately .Transport charges upto 50KM Per Metric Ton@Rs 16/KM										
159	Installation of Fire Extinguisher (5kG DCP) by means of proper hooks clamps etc. as required including providing of grouting material (cement etc.) and painting of hooks/clamps. Scope exclude supply of hook/clamp	40	No.								
160	Painting of Pole In Black & Yellow Strips/Zebra as per TP Central Orissa Distribution Ltd. specifications and indexing/numbering of Poles as per GIS format, scope also include site survey for GIS indexing and supply of ISI Marked good quality paint. (this item shall be paid for old poles only and where this not mentioned in scope)	88	No.								
161	Installation of 11KV CTPT Unit with all connection & Earthing as per TPCODL Drawing	5	No								
<b>Total All Inclusive Price</b>											



**TP CENTRAL ODISHA DISTRIBUTION LIMITED**  
(A Tata Power & Odisha Govt. joint venture)  
2nd Floor, IDCO Tower, Janpath Bhubaneshwar, Odisha 751022

NIT No.: TPCODL/P&S/72/2020-21

**Lot-3-Schedule for Items for BBSR-II – BED & BBSR-II NED Division**

Sr No	Item Description	Qty	Unit	HSN /SAC Code	Unit Ex-Work Price (Rs./Unit)	GST (Rs/Unit)	Other Taxes and Duties (Rs/Unit)	Freight & Insurance Charges (Rs/Unit)	GST on Freight & Insurance Charges (Rs/Unit)	All Inclusive Unit Rate (Rs.)	Total All Inclusive Value (Rs.)
1	Supply of 150x150mm RS Joist Pole ( 11mtr )	4	No								
2	Supply of 150x150mm RS Joist Pole ( 13mtr )	2	No.								
3	9 mtr. long 116X100 RS Joist Pole(23.0Kg per Meter)	2	No.								
4	9 mtr. long 300 Kg. PSC Pole	3	No.								
5	Supply of 11 KV V cross Arm (10.2 K.g. each )	48	No.								
6	Supply of Top bracket 75x40mm MS channel ( 1.3kg each)for 11KV	48	No.								
7	Supply of Back Clamp for V cross Arm 1.70Kg each For 11KV pole	144	Pair								
8	Supply of 11 K.V.GI Pin	144	No.								
9	Supply of 11 K.V. Pin Insulator polymer	144	No.								
10	Supply of 11 K.V. H.W. Fitting (B & S)	86	No.								
11	Supply of 11 K.V. polymer Insulator (B & S) Double Disc 70KN	518	No.								
12	Supply of H.T. Stay set (Complete ) for 11KV	29	Set								
13	Supply of H.T. Stay Insulator for 11KV pole	29	No.								







**TP CENTRAL ODISHA DISTRIBUTION LIMITED**  
(A Tata Power & Odisha Govt. joint venture)  
2nd Floor, IDCO Tower, Janpath Bhubaneshwar, Odisha 751022

NIT No.: TPCODL/P&S/72/2020-21

29	Supply of 11KV AB Switch 3 Pole (400 Amp.)	2.4	Set								
30	Supply of 11KV HG Fuse 3 Pole (400 Amp.)	20	No.								
31	Supply of 11 KV L.A. 12KV-10KA	60	No.								
32	Supply of Pressure Channel 100 x 50 x 6mm MS channel each 2.8 mtr. Long( 9.2 K.g. per mtr.)X2 Nos ( Per Transformer H pole - 51.52Kg)	1030.4	Kg								
33	Supply of Transformer mounting channel 100 x 50 x 6mm MS channel each 2.8 mtr. Long( 9.2 K.g. per mtr.)X2 Nos (Per Transformer H pole -51.52Kg)	1030.4	Kg								
34	Supply of MS Angle for mounting AB Swith & HG .Channel size 75x40x6 -2.8 mtr.long, 4 nos.(6.8K.g. per mtr.)-76.16Kg per H-Pole	1523.2	Kg								
35	Supply of MS Angle for Cantilever channel for supporting AB Switch arm, Channel size 75x40x6-1 mtr. Long, 2 nos.(6.8 K.g. per mtr.) - 13.6Kg per H -Pole	272	Kg								
36	Supply of MS Angle for Cantilever channel for supporting HG Fuse . Channel size 50 x 50 x 6 mm MS Angel (1.0 mtrs. Long 2 nos.)4.5K.g. per mtr. (9Kg per TRF H Pole)	180	Kg								



**TP CENTRAL ODISHA DISTRIBUTION LIMITED**  
(A Tata Power & Odisha Govt. joint venture)  
2nd Floor, IDCO Tower, Janpath Bhubaneshwar, Odisha 751022

NIT No.: TPCODL/P&S/72/2020-21

37	Supply of MS Angle for Cantilever arrangement for AB Switch & HG Fuse. Channel size 50 x 50 x 6 -2 mtr .each 2 nos.(4.5 K.g. per mtr.) ( 18K.g. per TRF H pole)	360	Kg																
38	Supply of MS Angle for Transformer belting. Angle size 50 x 50 x 6 mm - 2.8 mtr. Long 2 nos.(4.5 K.g. per mtr.) with side angel ( Total 7 mtr.)(31.5Kg per TRF H Pole)	630	Kg																
39	Supply of MS Angle for mounting LT distribution Box 50 x 50 x 6 mm MS Angel -2.5 mtrs. each Long 2 nos.( 4.5 Kg per mtr.)(22.5Kg per TRF H Pole)	450	Kg																
40	Supply of L.T. Distribution box including Kit Kat fuse with MCCB for 25KVA S/S ( As pre CESU specification)	10	No.																
41	Supply of 3 1/2C x 35mm <sup>2</sup> PVC Cable for 25KVA TFR.	150	Mtr																
42	Supply of L.T. Distribution box with MCCB, Aluminium Busbar for 2bay with Kit Kat fuse for 100KVA S/S	4	No.																
43	Supply of 3 1/2C x 150mm <sup>2</sup> PVC Cable for 100 KVA TFR	6	Mtr																
44	Supply of L.T. Distribution box with MCCB, Aluminium Busbar for 3bay with Kit Kat fuse for 250KVA S/S	2	No.																



**TP CENTRAL ODISHA DISTRIBUTION LIMITED**  
(A Tata Power & Odisha Govt. joint venture)  
2nd Floor, IDCO Tower, Janpath Bhubaneshwar, Odisha 751022

NIT No.: TPCODL/P&S/72/2020-21

45	Supply of 3 1/2C x 300mm <sup>2</sup> PVC Cable for 500 KVA TFR I/C	6	Mtr								
46	Supply of Concrete slab for base place size 2ftx2ftx2" thickness for each PSC pole	79	No.								
47	Supply of LT Stay set Complete	19	Set								
48	Supply of 7/12 SWG Stay Wire	192	Kg								
49	Supply of LT Stay clamp (1.4 K.g./ Pair )	19	pair								
50	Supply of LT Stay Insulator	19	No.								
51	Supply of Dead end clamp	24	No.								
52	Supply of Suspension clamp with I-Hook	72	No.								
53	Supply of Strain fittings	19	No.								
54	Supply of Guy grip Dead end for Pole	19	No.								
55	Supply of Nuts and Bolts	57.6	Kg								
56	Supply Earthing Coil each 5th pole to earth	17	No.								
57	Supply of AB Cable( 3 x50 + 1x35mm <sup>2</sup> )	0.1	Km								
58	Supply of AB Cable( 3 x35 + 1x25mm <sup>2</sup> )	1	Km								
59	Supply of AB Cable( 3 x50 + 1x35mm <sup>2</sup> +1X16mm <sup>2</sup> )	0.1	Km								
60	Supply of AB Cable( 3 x95 + 1x70mm <sup>2</sup> +1X16mm <sup>2</sup> )	0.1	Km								
61	Supply of 1.1KV, 4C, 240Sqmm for XLPE Cable, AL,ARM	50	Mtr.								
62	Supply of 1.1KV, 4C, 300Sqmm for XLPE Cable,AL,ARM	50	No.								





**TP CENTRAL ODISHA DISTRIBUTION LIMITED**  
(A Tata Power & Odisha Govt. joint venture)  
2nd Floor, IDCO Tower, Janpath Bhubaneshwar, Odisha 751022

NIT No.: TPCODL/P&S/72/2020-21

75	Supply 3CX 300Sqmm,11KV Indoor Termination Kit	2	No.								
76	Supply 3CX 400Sqmm,11KV Indoor Termination Kit	2	No.								
77	Supply 3CX 120Sqmm,11KV Indoor Termination Kit	2	No.								
78	Supply 3CX 185Sqmm,11KV Indoor Termination Kit	2	No.								
79	Supply 3CX 95Sqmm,11KV Indoor Termination Kit	2	No.								
80	Supply 3CX 400Sqmm,11KV Outdoor Termination Kit	2	No.								
81	Supply 3CX 300Sqmm,11KV Outdoor Termination Kit	2	No.								
82	Supply 3CX 185Sqmm,11KV Outdoor Termination Kit	2	No.								
83	Supply 3CX 120Sqmm,11KV Outdoor Termination Kit	2	No.								
84	3P 4 W 11 KV CT PT Combined Metering Unit Class of Accuracy 0.5 with CTR 20/5 A, with burden 15VA, PT with Burden 50VA	4	No								
85	Supply of 4C X 4Sqmm AL PVC Service cable un Arm for releasing 1PH	36720	Mtr								
86	Supply 3.5C * 35Sqmm LT PVC Cable Un armoured	12240	Mtr								
87	Supply 3.5C * 50qmm LT PVC Cable Un armoured	4896	Mtr								
88	Supply 3.5C * 95Sqmm LT PVC Cable Un armoured	4896	Mtr								





**TP CENTRAL ODISHA DISTRIBUTION LIMITED**  
(A Tata Power & Odisha Govt. joint venture)  
2nd Floor, IDCO Tower, Janpath Bhubaneshwar, Odisha 751022

NIT No.: TPCODL/P&S/72/2020-21

	using 40mm BHG metal with all labor and material except stay set , stay wire , stay insulator .										
102	Installation of Earthing of Support ( Coil Type )	88	No.								
103	Installation of Earth Pit, Charcoal, Salt etc. including construction of earthing chamber (Size: 2'x2') and RCC slab cover	100	No.								
104	Stringing of 80-100mm <sup>2</sup> AAAC	2.4	KM								
105	Painting of RS Joist Pole with fittings 2 coats of Al paint over a coat of red oxide primer including all Tools & Tackle	88	No.								
106	Installation, Testing and Commissioning of 11/0.4kV, 25kVA 3-Phase Distribution Transformer on existing structure as per TP Central Orissa Distribution Ltd. specification including loading, unloading, shifting/transportation from Division store to site /tent. Scope of work includes, jumpering/connection at HT and LT side , including minor site modification as per the TPCODL Standard Excluding Earthing	10	EA								
107	Installation, Testing and Commissioning of 11/0.4kV, 63kVA 3-Phase Distribution Transformer on existing structure	4	EA								



**TP CENTRAL ODISHA DISTRIBUTION LIMITED**  
(A Tata Power & Odisha Govt. joint venture)  
2nd Floor, IDCO Tower, Janpath Bhubaneshwar, Odisha 751022

NIT No.: TPCODL/P&S/72/2020-21

	as per TP Central Orissa Distribution Ltd. specification including loading, unloading, shifting/transportation from Division store to site /tent. Scope of work includes, jumpering/connection at HT and LT side , including minor site modification as per the TPCODL Standard Excluding Earthing										
108	Installation, Testing and Commissioning of 11/0.4kV, 100kVA 3-Phase Distribution Transformer on existing structure as per TP Central Orissa Distribution Ltd. specification including loading, unloading, shifting/transportation from Division store to site /tent. Scope of work includes, jumpering/connection at HT and LT side , including minor site modification as per the TPCODL Standard Excluding Earthing	4	EA								
109	Installation, Testing and Commissioning of 11/0.4kV, 250kVA 3-Phase Distribution Transformer on existing structure as per TP Central Orissa Distribution Ltd. specification including loading, unloading, shifting/transportation from site /tent. Scope of work includes	2	EA								





**TP CENTRAL ODISHA DISTRIBUTION LIMITED**  
(A Tata Power & Odisha Govt. joint venture)  
2nd Floor, IDCO Tower, Janpath Bhubaneshwar, Odisha 751022

NIT No.: TPCODL/P&S/72/2020-21

	earthing, jumpering/connection at HT and LT side as per the TPCODL Standard										
110	Installation of Outdoor Type Distribution Box with 40A MCCB with O/G for 11/0.4kV,25kVA Three Phase Transformer as per TP Central Orissa Distribution Ltd. specification	10	No								
111	Installation of Outdoor Type Distribution Box with 100A MCCB with O/G for 11/0.4kV,63kVA Three Phase Transformer as per TP Central Orissa Distribution Ltd. specification	4	No								
112	Installation of Outdoor Type Distribution Box (BOX DIST.WITH 160A 35KA TP MCCB 6 O/G) for 100KVA TRF	4	No								
113	Installation testing and commissioning of LT ACB 400 Amps with enclosure for 11/0.4KV 250KVA Threephase Transformer	2	No								
114	Installation of Outdoor Type Distribution Box(BOX DIST.WITH 500A 50KA TP MCCB 5 O/G) with MCCB for 11/0.4kV,250kVA Three Phase Transformer on existing structure as per TP Central Orissa Distribution Ltd. Specification	2	No								
115	Plinth for TFR 6ft hight (below GL2ft)x5ftx5ft	6	No								



**TP CENTRAL ODISHA DISTRIBUTION LIMITED**  
(A Tata Power & Odisha Govt. joint venture)  
2nd Floor, IDCO Tower, Janpath Bhubaneshwar, Odisha 751022

NIT No.: TPCODL/P&S/72/2020-21

116	Plinth for L.T. Distribution box 6ft high (below GL2ft)x5ftx5ft	2	No								
117	Installation of GI barbed wire anticlimbing device 2 Kg. Per support	176	Kg								
118	Installation of different size MS Channel for 50 S/S	5440	Kg								
119	Installation of different size MS Channel for DP in 6KM line	945.6	Kg								
120	Supply of GI Nut , Bolt & Washer of different sizes For line with DP for 6KM Line (70KG PER KM LINE)	168	Kg								
121	Supply of GI Nut , Bolt & Washer of different sizes For 50S/S ( 36KG Per s/s)	720	Kg								
122	Painting of RS Joist	88	No								
123	Dismantling of RS Joist pole(150x150mm/Rail pole) & return back to section store	8	No								
124	Dismantling of RS Joist pole(116x100mm)	8	No								
125	Dismantling of PSC pole (9mtr)	8	No								
126	Dismantling of 11KV 'V' Cross arm	8	No								
127	Dismantling of 11KV GI pin with insulator	24	No								
128	Dismantling of 11KV Disc insulator with HW Fitting	24	No								
129	Dismantling of MS Channel from 11KV Pole / DP	40	Kg								
130	Dismantling of 55mm <sup>2</sup> AAA Conductor	0.2	KM								



**TP CENTRAL ODISHA DISTRIBUTION LIMITED**  
(A Tata Power & Odisha Govt. joint venture)  
2nd Floor, IDCO Tower, Janpath Bhubaneshwar, Odisha 751022

NIT No.: TPCODL/P&S/72/2020-21

131	Dismantling of 80mm <sup>2</sup> AAA Conductor	0.2	KM								
132	Dismantling of 100mm <sup>2</sup> AAA Conductor	0.2	KM								
133	Sundries for survey tree cutting, small size nut bolt, Aluminium Binding wire / tape & Danger Board 4 Nos. etc. Line length of 1KM	2.4	LS								
134	Sundries for survey tree cutting, small size nut bolt, Aluminium. Binding wire / tape & Danger Board 4 Nos. etc. Substation upto 250KVA	20	LS								
135	Installation of Dead end clamp on LT Pole	24	No.								
136	Installation of Suspension clamp with I-Hook on LT Pole	72	No.								
137	Installation of Strain fittings on LT pole	19	No.								
138	Installation of Guy grip Dead end for LT Pole	19	No.								
139	Installation of Earthing Coil TO POLE	17	No.								
140	Laying / stringing of AB Cable( 3 x50 + 1x35mm <sup>2</sup> )	2400	Mtr.								
141	Laying / Stringing of AB Cable( 3 x35 + 1x25mm <sup>2</sup> )	2400	Mtr.								
142	Laying / Stringing of AB Cable( 3 x50 + 1x35mm <sup>2</sup> +1X16mm <sup>2</sup> )	2400	Mtr.								
143	Laying / Stringing of AB Cable( 3 x95 + 1x70mm <sup>2</sup> +1X16mm <sup>2</sup> )	2400	Mtr.								



**TP CENTRAL ODISHA DISTRIBUTION LIMITED**  
 (A Tata Power & Odisha Govt. joint venture)  
 2nd Floor, IDCO Tower, Janpath Bhubaneshwar, Odisha 751022

NIT No.: TPCODL/P&S/72/2020-21

144	Laying of Service cable 4sqmm x 2C	2	Mtr.								
145	Laying of 1.1KV 3.5C, 35Sqmm AL XLPE Cable	12240	Mtr.								
146	Laying of 1.1KV 3.5C, 150SqmmAL XLPE Cable	4896	Mtr.								
147	Laying of 1.1KV 4C, 240Sqmm AL XLPE Cable	4896	Mtr.								
148	Laying of 1.1KV 3.5C, 300Sqmm AL XLPE Cable	50	Mtr.								
149	Laying & EXCAVATION (1M Depth * 0.875M Width) of 11kV Armoured XLPE AL Cable 3CX95 sqmm/ 3CX120 sqmm in S/Sth. Trench/Tray as per TP Central Orissa Distribution Ltd. specification including testing of cable. Scope of work exclude fixing of Tray.BA will provide support during joint making by OEM of joint kit,no separate payment will be paid to BA for this support by BA	50	Mtr.								
150	Laying & Excavation (1M Depth * 0.875M) of 11kV Armoured XLPE AL Cable 3CX400/ 3X300 sqmm in S/Sth. Trench/Tray as per TP Central Orissa Distribution Ltd. specification including testing of cable. Scope of work exclude fixing of Tray.BA will provide support during joint making by	50	Mtr.								



**TP CENTRAL ODISHA DISTRIBUTION LIMITED**  
(A Tata Power & Odisha Govt. joint venture)  
2nd Floor, IDCO Tower, Janpath Bhubaneshwar, Odisha 751022

NIT No.: TPCODL/P&S/72/2020-21

	OEM of joint kit, no separate payment will be paid to BA for this support by BA										
151	Jointing of I/D or O/D of HT (11KV) UGC & including all related work and Approved Jointer	2	No.								
152	Indoor / outdoor Termination of 11 kV Armoured XLPE, AL Cable 3CX95 sqmm, 120Sqmm, 185Sqmm, 300SQMM, 400SQMM including consumable	2	EA								
153	Construction of 11KV RMU Plinth with Brick, Mortar, 12 mm cement plaster and painting with enamel paint.	2	EA								
154	Installation, Testing and Commissioning of 11kV 3-way Ring Main Unit on existing structure/foundation as per TP Central Orissa Distribution Ltd. specification including grouting, loading, unloading, shifting/transportation from site/tent. Scope of work includes pipe earthing, jumpering/connection and modification to foundation at Site	2	EA								
155	Installation, Testing and Commissioning of 1.1kV Feeder pillar with new structure/foundation as per TP Central Orissa Distribution Ltd. specification	2	EA								



**TP CENTRAL ODISHA DISTRIBUTION LIMITED**  
(A Tata Power & Odisha Govt. joint venture)  
2nd Floor, IDCO Tower, Janpath Bhubaneshwar, Odisha 751022

NIT No.: TPCODL/P&S/72/2020-21

	including grouting, loading, unloading, shifting/transportation from site/tent. Scope of work includes Pipe earthing, jumpering/connection and modification to foundation at Site										
156	Extension of one LBS in existing 11KV RMU structure specification including grouting, loading, unloading, shifting/transportation from site/tent. Scope of work includes earthing, jumpering/connection and construction / modification of foundation	2	EA								
157	Supply & Installation of HT Danger Board as per TP Central Orissa Distribution Ltd. specification	400	No.								
158	Transportation of various items from TPCODL store/site to other site or vice versa in TPCODL operational area - Truck with labours as required (price per Km). Scope of work also include loading and unloading of materials including heavy items like HT Panel, Transformer, Cable Drum, LT Board where loading, unloading is to be done with crane and crane will be paid separately .Transport	100	MT/KM								



**TP CENTRAL ODISHA DISTRIBUTION LIMITED**  
(A Tata Power & Odisha Govt. joint venture)  
2nd Floor, IDCO Tower, Janpath Bhubaneshwar, Odisha 751022

NIT No.: TPCODL/P&S/72/2020-21

	charges upto 50KM Per Metric Ton@Rs 16/KM										
159	Installation of Fire Extinguisher (5kG DCP) by means of proper hooks clamps etc. as required including providing of grouting material (cement etc.) and painting of hooks/clamps. Scope exclude supply of hook/clamp	40	No.								
160	Painting of Pole In Black & Yellow Strips/Zebra as per TP Central Orissa Distribution Ltd. specifications and indexing/numbering of Poles as per GIS format, scope also include site survey for GIS indexing and supply of ISI Marked good quality paint. (this item shall be paid for old poles only and where this not mentioned in scope)	88	No.								
161	Installation of 11KV CTPT Unit with all connection & Earthing as per TPCODL Drawing	5	No								
<b>Total All Inclusive Price</b>											



**TP CENTRAL ODISHA DISTRIBUTION LIMITED**  
(A Tata Power & Odisha Govt. joint venture)  
2nd Floor, IDCO Tower, Janpath Bhubaneshwar, Odisha 751022

NIT No.: TPCODL/P&S/72/2020-21

**Lot-4-Schedule for Items for BBSR-II – PED & BBSR-II KED Division**

Sr No	Item Description	Qty	Unit	HSN /SAC Code	Unit Ex-Work Price (Rs./Unit)	GST (Rs/Unit)	Other Taxes and Duties (Rs/Unit)	Freight & Insurance Charges (Rs/Unit)	GST on Freight & Insurance Charges (Rs/Unit)	All Inclusive Unit Rate (Rs.)	Total All Inclusive Value (Rs.)
1	Supply of 150x150mm RS Joist Pole ( 11mtr )	4	No								
2	Supply of 150x150mm RS Joist Pole ( 13mtr )	2	No.								
3	9 mtr. long 116X100 RS Joist Pole(23.0Kg per Meter)	2	No.								
4	9 mtr. long 300 Kg. PSC Pole	3	No.								
5	Supply of 11 KV V cross Arm (10.2 K.g. each )	48	No.								
6	Supply of Top bracket 75x40mm MS channel ( 1.3kg each)for 11KV	48	No.								
7	Supply of Back Clamp for V cross Arm 1.70Kg each For 11KV pole	144	Pair								
8	Supply of 11 K.V.GI Pin	144	No.								
9	Supply of 11 K.V. Pin Insulator polymer	144	No.								
10	Supply of 11 K.V. H.W. Fitting (B & S)	86	No.								
11	Supply of 11 K.V. polymer Insulator (B & S) Double Disc 70KN	518	No.								
12	Supply of H.T. Stay set (Complete ) for 11KV	29	Set								
13	Supply of H.T. Stay Insulator for 11KV pole	29	No.								





**TP CENTRAL ODISHA DISTRIBUTION LIMITED**  
(A Tata Power & Odisha Govt. joint venture)  
2nd Floor, IDCO Tower, Janpath Bhubaneshwar, Odisha 751022

NIT No.: TPCODL/P&S/72/2020-21

14	Supply of H.T. Stay clamp (1.95 K.g./ Pair ) for 11KV Pole	29	Pair								
15	Supply of 7/10 SWG Stay Wire 10kg /stay for 11KV Pole	288	K.g.								
16	Supply of Earthing of Support for 11KV Pole ( Coil Type )	48	No.								
17	Supply of Red Oxide paint (1.2Kg per 11KV Pole)	57.6	Ltr								
18	Supply of Aluminium Paint ( 1.2Kg per 11KV Pole)	57.6	Ltr								
19	Supply of Black Paint ( 0.3Kg per 11KV Pole)	14.4	Ltr								
20	Supply of GI barbed wire anticlimbing device 2 Kg. Per support for 11KV Pole	96	Kg								
21	Supply of 100 x 50 x 6 mm MS channel for 4nos Cut point ( 52Kg per Cutpoint)	748.8	Kg								
22	Supply of 75 x 40 x 6 mm MS channel for 11KV DP	196.8	Kg								
23	Supply of 50X50X6mm Cross Bressing Angel for of 11KV DP	196.8	Kg								
24	Supply of GI Pipe for Earthing 40 Dia Medium gage 3 mtrs. Long	100	No.								
25	40x6mm GI Flat for neutral	400	Kg								
26	Supply of 3 1/2 x 35mm <sup>2</sup> PVC Cable for 25KVA TFR.	150	Mtr								
27	Supply of Ms Nut , Bolt & Washer of different sizes	42.4	Kg								
28	Supply of 11KV AB Switch 3 Pole (200 Amp.)	20	Set								



**TP CENTRAL ODISHA DISTRIBUTION LIMITED**  
(A Tata Power & Odisha Govt. joint venture)  
2nd Floor, IDCO Tower, Janpath Bhubaneshwar, Odisha 751022

NIT No.: TPCODL/P&S/72/2020-21

29	Supply of 11KV AB Switch 3 Pole (400 Amp.)	2.4	Set								
30	Supply of 11KV HG Fuse 3 Pole (400 Amp.)	20	No.								
31	Supply of 11 KV L.A. 12KV-10KA	60	No.								
32	Supply of Pressure Channel 100 x 50 x 6mm MS channel each 2.8 mtr. Long( 9.2 K.g. per mtr.)X2 Nos ( Per Transformer H pole - 51.52Kg)	1030.4	Kg								
33	Supply of Transformer mounting channel 100 x 50 x 6mm MS channel each 2.8 mtr. Long( 9.2 K.g. per mtr.)X2 Nos (Per Transformer H pole -51.52Kg)	1030.4	Kg								
34	Supply of MS Angle for mounting AB Swith & HG .Channel size 75x40x6 -2.8 mtr.long, 4 nos.(6.8K.g. per mtr.)-76.16Kg per H-Pole	1523.2	Kg								
35	Supply of MS Angle for Cantilever channel for supporting AB Switch arm, Channel size 75x40x6-1 mtr. Long, 2 nos.(6.8 K.g. per mtr.) - 13.6Kg per H -Pole	272	Kg								
36	Supply of MS Angle for Cantilever channel for supporting HG Fuse . Channel size 50 x 50 x 6 mm MS Angel (1.0 mtrs. Long 2 nos.)4.5K.g. per mtr. (9Kg per TRF H Pole)	180	Kg								



**TP CENTRAL ODISHA DISTRIBUTION LIMITED**  
(A Tata Power & Odisha Govt. joint venture)  
2nd Floor, IDCO Tower, Janpath Bhubaneshwar, Odisha 751022

NIT No.: TPCODL/P&S/72/2020-21

37	Supply of MS Angle for Cantilever arrangement for AB Switch & HG Fuse. Channel size 50 x 50 x 6 -2 mtr .each 2 nos.(4.5 K.g. per mtr.) ( 18K.g. per TRF H pole)	360	Kg																	
38	Supply of MS Angle for Transformer belting. Angle size 50 x 50 x 6 mm - 2.8 mtr. Long 2 nos.(4.5 K.g. per mtr.) with side angel ( Total 7 mtr.)(31.5Kg per TRF H Pole)	630	Kg																	
39	Supply of MS Angle for mounting LT distribution Box 50 x 50 x 6 mm MS Angel -2.5 mtrs. each Long 2 nos.( 4.5 Kg per mtr.)(22.5Kg per TRF H Pole)	450	Kg																	
40	Supply of L.T. Distribution box including Kit Kat fuse with MCCB for 25KVA S/S ( As pre CESU specification)	10	No.																	
41	Supply of 3 1/2C x 35mm <sup>2</sup> PVC Cable for 25KVA TFR.	150	Mtr																	
42	Supply of L.T. Distribution box with MCCB, Aluminium Busbar for 2bay with Kit Kat fuse for 100KVA S/S	4	No.																	
43	Supply of 3 1/2C x 150mm <sup>2</sup> PVC Cable for 100 KVA TFR	6	Mtr																	
44	Supply of L.T. Distribution box with MCCB, Aluminium Busbar for 3bay with Kit Kat fuse for 250KVA S/S	2	No.																	



**TP CENTRAL ODISHA DISTRIBUTION LIMITED**  
(A Tata Power & Odisha Govt. joint venture)  
2nd Floor, IDCO Tower, Janpath Bhubaneshwar, Odisha 751022

NIT No.: TPCODL/P&S/72/2020-21

45	Supply of 3 1/2C x 300mm <sup>2</sup> PVC Cable for 500 KVA TFR I/C	6	Mtr								
46	Supply of Concrete slab for base place size 2ftx2ftx2" thickness for each PSC pole	79	No.								
47	Supply of LT Stay set Complete	19	Set								
48	Supply of 7/12 SWG Stay Wire	192	Kg								
49	Supply of LT Stay clamp (1.4 K.g./ Pair )	19	pair								
50	Supply of LT Stay Insulator	19	No.								
51	Supply of Dead end clamp	24	No.								
52	Supply of Suspension clamp with I-Hook	72	No.								
53	Supply of Strain fittings	19	No.								
54	Supply of Guy grip Dead end for Pole	19	No.								
55	Supply of Nuts and Bolts	57.6	Kg								
56	Supply Earthing Coil each 5th pole to earth	17	No.								
57	Supply of AB Cable( 3 x50 + 1x35mm <sup>2</sup> )	0.1	Km								
58	Supply of AB Cable( 3 x35 + 1x25mm <sup>2</sup> )	1	Km								
59	Supply of AB Cable( 3 x50 + 1x35mm <sup>2</sup> +1X16mm <sup>2</sup> )	0.1	Km								
60	Supply of AB Cable( 3 x95 + 1x70mm <sup>2</sup> +1X16mm <sup>2</sup> )	0.1	Km								
61	Supply of 1.1KV, 4C, 240Sqmm for XLPE Cable, AL,ARM	50	Mtr.								
62	Supply of 1.1KV, 4C, 300Sqmm for XLPE Cable,AL,ARM	50	No.								



**TP CENTRAL ODISHA DISTRIBUTION LIMITED**  
(A Tata Power & Odisha Govt. joint venture)  
2nd Floor, IDCO Tower, Janpath Bhubaneshwar, Odisha 751022

NIT No.: TPCODL/P&S/72/2020-21

63	Supply of 11KV, 3C, 95Sqmm for XLPE Cable,AL,ARM	50	No.																
64	Supply of 11KV, 3C, 120Sqmm for XLPE Cable,AL,ARM	50	No.																
65	Supply of 11KV, 3C, 185Sqmm for XLPE Cable,AL,ARM	50	No.																
66	Supply of 11KV, 3C, 300Sqmm for XLPE Cable,AL,ARM	50	No.																
67	Supply of 11KV, 3C, 400Sqmm for XLPE Cable,AL,ARM	50	No.																
68	Supply of 11KV 3C, 400Sqmm Straight thru Jointing KIT, HS for XLPE Cable for Indoor	2	No.																
69	Supply of 11KV, 3C, 300Sqmm Straight thru Jointing KIT ,HS for XLPE Cable	2	No.																
70	Supply of 11KV , 3C, 120Sqmm Straight thru Jointing KIT ,HS for XLPE Cable	2	No.																
71	Supply of 11KV , 3C, 95Sqmm Straight thru Jointing KIT ,HS for XLPE Cable	2	No.																
72	Supply of 1.1KV 4C 300Sqmm Straight thru Jointing KIT,HS for XLPE Cable	2	No.																
73	Supply of 1.1KV 4C 150Sqmm Straight thru Jointing KIT,HS for XLPE Cable	2	No.																
74	Supply of 1.1KV 4C 95Sqmm Straight thru Jointing KIT,HS for XLPE Cable	2	No.																



**TP CENTRAL ODISHA DISTRIBUTION LIMITED**  
(A Tata Power & Odisha Govt. joint venture)  
2nd Floor, IDCO Tower, Janpath Bhubaneshwar, Odisha 751022

NIT No.: TPCODL/P&S/72/2020-21

75	Supply 3CX 300Sqmm,11KV Indoor Termination Kit	2	No.								
76	Supply 3CX 400Sqmm,11KV Indoor Termination Kit	2	No.								
77	Supply 3CX 120Sqmm,11KV Indoor Termination Kit	2	No.								
78	Supply 3CX 185Sqmm,11KV Indoor Termination Kit	2	No.								
79	Supply 3CX 95Sqmm,11KV Indoor Termination Kit	2	No.								
80	Supply 3CX 400Sqmm,11KV Outdoor Termination Kit	2	No.								
81	Supply 3CX 300Sqmm,11KV Outdoor Termination Kit	2	No.								
82	Supply 3CX 185Sqmm,11KV Outdoor Termination Kit	2	No.								
83	Supply 3CX 120Sqmm,11KV Outdoor Termination Kit	2	No.								
84	3P 4 W 11 KV CT PT Combined Metering Unit Class of Accuracy 0.5 with CTR 20/5 A, with burden 15VA, PT with Burden 50VA	4	No								
85	Supply of 4C X 4Sqmm AL PVC Service cable un Arm for releasing 1PH	36720	Mtr								
86	Supply 3.5C * 35Sqmm LT PVC Cable Un armoured	12240	Mtr								
87	Supply 3.5C * 50qmm LT PVC Cable Un armoured	4896	Mtr								
88	Supply 3.5C * 95Sqmm LT PVC Cable Un armoured	4896	Mtr								





**TP CENTRAL ODISHA DISTRIBUTION LIMITED**  
(A Tata Power & Odisha Govt. joint venture)  
2nd Floor, IDCO Tower, Janpath Bhubaneshwar, Odisha 751022

NIT No.: TPCODL/P&S/72/2020-21

	using 40mm BHG metal with all labor and material except stay set , stay wire , stay insulator .										
102	Installation of Earthing of Support ( Coil Type )	88	No.								
103	Installation of Earth Pit, Charcoal, Salt etc. including construction of earthing chamber (Size: 2'x2') and RCC slab cover	100	No.								
104	Stringing of 80-100mm <sup>2</sup> AAAC	2.4	KM								
105	Painting of RS Joist Pole with fittings 2 coats of Al paint over a coat of red oxide primer including all Tools & Tackle	88	No.								
106	Installation, Testing and Commissioning of 11/0.4kV, 25kVA 3-Phase Distribution Transformer on existing structure as per TP Central Orissa Distribution Ltd. specification including loading, unloading, shifting/transportation from Division store to site /tent. Scope of work includes, jumpering/connection at HT and LT side , including minor site modification as per the TPCODL Standard Excluding Earthing	10	EA								
107	Installation, Testing and Commissioning of 11/0.4kV, 63kVA 3-Phase Distribution Transformer on existing structure	4	EA								





**TP CENTRAL ODISHA DISTRIBUTION LIMITED**  
(A Tata Power & Odisha Govt. joint venture)  
2nd Floor, IDCO Tower, Janpath Bhubaneshwar, Odisha 751022

NIT No.: TPCODL/P&S/72/2020-21

	as per TP Central Orissa Distribution Ltd. specification including loading, unloading, shifting/transportation from Division store to site /tent. Scope of work includes, jumpering/connection at HT and LT side , including minor site modification as per the TPCODL Standard Excluding Earthing										
108	Installation, Testing and Commissioning of 11/0.4kV, 100kVA 3-Phase Distribution Transformer on existing structure as per TP Central Orissa Distribution Ltd. specification including loading, unloading, shifting/transportation from Division store to site /tent. Scope of work includes, jumpering/connection at HT and LT side , including minor site modification as per the TPCODL Standard Excluding Earthing	4	EA								
109	Installation, Testing and Commissioning of 11/0.4kV, 250kVA 3-Phase Distribution Transformer on existing structure as per TP Central Orissa Distribution Ltd. specification including loading, unloading, shifting/transportation from site /tent. Scope of work includes	2	EA								



**TP CENTRAL ODISHA DISTRIBUTION LIMITED**  
(A Tata Power & Odisha Govt. joint venture)  
2nd Floor, IDCO Tower, Janpath Bhubaneshwar, Odisha 751022

NIT No.: TPCODL/P&S/72/2020-21

	earthing, jumpering/connection at HT and LT side as per the TPCODL Standard										
110	Installation of Outdoor Type Distribution Box with 40A MCCB with O/G for 11/0.4kV,25kVA Three Phase Transformer as per TP Central Orissa Distribution Ltd. specification	10	No								
111	Installation of Outdoor Type Distribution Box with 100A MCCB with O/G for 11/0.4kV,63kVA Three Phase Transformer as per TP Central Orissa Distribution Ltd. specification	4	No								
112	Installation of Outdoor Type Distribution Box (BOX DIST.WITH 160A 35KA TP MCCB 6 O/G) for 100KVA TRF	4	No								
113	Installation testing and commissioning of LT ACB 400 Amps with enclosure for 11/0.4KV 250KVA Threephase Transformer	2	No								
114	Installation of Outdoor Type Distribution Box(BOX DIST.WITH 500A 50KA TP MCCB 5 O/G) with MCCB for 11/0.4kV,250kVA Three Phase Transformer on existing structure as per TP Central Orissa Distribution Ltd. Specification	2	No								
115	Plinth for TFR 6ft hight (below GL2ft)x5ftx5ft	6	No								



**TP CENTRAL ODISHA DISTRIBUTION LIMITED**  
(A Tata Power & Odisha Govt. joint venture)  
2nd Floor, IDCO Tower, Janpath Bhubaneshwar, Odisha 751022

NIT No.: TPCODL/P&S/72/2020-21

116	Plinth for L.T. Distribution box 6ft high (below GL2ft)x5ftx5ft	2	No								
117	Installation of GI barbed wire anticlimbing device 2 Kg. Per support	176	Kg								
118	Installation of different size MS Channel for 50 S/S	5440	Kg								
119	Installation of different size MS Channel for DP in 6KM line	945.6	Kg								
120	Supply of GI Nut , Bolt & Washer of different sizes For line with DP for 6KM Line (70KG PER KM LINE)	168	Kg								
121	Supply of GI Nut , Bolt & Washer of different sizes For 50S/S ( 36KG Per s/s)	720	Kg								
122	Painting of RS Joist	88	No								
123	Dismantling of RS Joist pole(150x150mm/Rail pole) & return back to section store	8	No								
124	Dismantling of RS Joist pole(116x100mm)	8	No								
125	Dismantling of PSC pole (9mtr)	8	No								
126	Dismantling of 11KV 'V' Cross arm	8	No								
127	Dismantling of 11KV GI pin with insulator	24	No								
128	Dismantling of 11KV Disc insulator with HW Fitting	24	No								
129	Dismantling of MS Channel from 11KV Pole / DP	40	Kg								
130	Dismantling of 55mm <sup>2</sup> AAA Conductor	0.2	KM								



**TP CENTRAL ODISHA DISTRIBUTION LIMITED**  
(A Tata Power & Odisha Govt. joint venture)  
2nd Floor, IDCO Tower, Janpath Bhubaneshwar, Odisha 751022

NIT No.: TPCODL/P&S/72/2020-21

131	Dismantling of 80mm <sup>2</sup> AAA Conductor	0.2	KM								
132	Dismantling of 100mm <sup>2</sup> AAA Conductor	0.2	KM								
133	Sundries for survey tree cutting, small size nut bolt, Aluminium Binding wire / tape & Danger Board 4 Nos. etc. Line length of 1KM	2.4	LS								
134	Sundries for survey tree cutting, small size nut bolt, Aluminium. Binding wire / tape & Danger Board 4 Nos. etc. Substation upto 250KVA	20	LS								
135	Installation of Dead end clamp on LT Pole	24	No.								
136	Installation of Suspension clamp with I-Hook on LT Pole	72	No.								
137	Installation of Strain fittings on LT pole	19	No.								
138	Installation of Guy grip Dead end for LT Pole	19	No.								
139	Installation of Earthing Coil TO POLE	17	No.								
140	Laying / stringing of AB Cable( 3 x50 + 1x35mm <sup>2</sup> )	2400	Mtr.								
141	Laying / Stringing of AB Cable( 3 x35 + 1x25mm <sup>2</sup> )	2400	Mtr.								
142	Laying / Stringing of AB Cable( 3 x50 + 1x35mm <sup>2</sup> +1X16mm <sup>2</sup> )	2400	Mtr.								
143	Laying / Stringing of AB Cable( 3 x95 + 1x70mm <sup>2</sup> +1X16mm <sup>2</sup> )	2400	Mtr.								



**TP CENTRAL ODISHA DISTRIBUTION LIMITED**  
(A Tata Power & Odisha Govt. joint venture)  
2nd Floor, IDCO Tower, Janpath Bhubaneshwar, Odisha 751022

NIT No.: TPCODL/P&S/72/2020-21

144	Laying of Service cable 4sqmm x 2C	2	Mtr.								
145	Laying of 1.1KV 3.5C, 35Sqmm AL XLPE Cable	12240	Mtr.								
146	Laying of 1.1KV 3.5C, 150SqmmAL XLPE Cable	4896	Mtr.								
147	Laying of 1.1KV 4C, 240Sqmm AL XLPE Cable	4896	Mtr.								
148	Laying of 1.1KV 3.5C, 300Sqmm AL XLPE Cable	50	Mtr.								
149	Laying & EXCAVATION (1M Depth * 0.875M Width) of 11kV Armoured XLPE AL Cable 3CX95 sqmm/ 3CX120 sqmm in S/Sth. Trench/Tray as per TP Central Orissa Distribution Ltd. specification including testing of cable. Scope of work exclude fixing of Tray.BA will provide support during joint making by OEM of joint kit,no separate payment will be paid to BA for this support by BA	50	Mtr.								
150	Laying & Excavation (1M Depth * 0.875M) of 11kV Armoured XLPE AL Cable 3CX400/ 3X300 sqmm in S/Sth. Trench/Tray as per TP Central Orissa Distribution Ltd. specification including testing of cable. Scope of work exclude fixing of Tray.BA will provide support during joint making by	50	Mtr.								



**TP CENTRAL ODISHA DISTRIBUTION LIMITED**  
(A Tata Power & Odisha Govt. joint venture)  
2nd Floor, IDCO Tower, Janpath Bhubaneshwar, Odisha 751022

NIT No.: TPCODL/P&S/72/2020-21

	OEM of joint kit, no separate payment will be paid to BA for this support by BA										
151	Jointing of I/D or O/D of HT (11KV) UGC & including all related work and Approved Jointer	2	No.								
152	Indoor / outdoor Termination of 11 kV Armoured XLPE, AL Cable 3CX95 sqmm, 120Sqmm, 185Sqmm, 300SQMM, 400SQMM including consumable	2	EA								
153	Construction of 11KV RMU Plinth with Brick, Mortar, 12 mm cement plaster and painting with enamel paint.	2	EA								
154	Installation, Testing and Commissioning of 11kV 3-way Ring Main Unit on existing structure/foundation as per TP Central Orissa Distribution Ltd. specification including grouting, loading, unloading, shifting/transportation from site/tent. Scope of work includes pipe earthing, jumpering/connection and modification to foundation at Site	2	EA								
155	Installation, Testing and Commissioning of 1.1kV Feeder pillar with new structure/foundation as per TP Central Orissa Distribution Ltd. specification	2	EA								



**TP CENTRAL ODISHA DISTRIBUTION LIMITED**  
(A Tata Power & Odisha Govt. joint venture)  
2nd Floor, IDCO Tower, Janpath Bhubaneshwar, Odisha 751022

NIT No.: TPCODL/P&S/72/2020-21

	including grouting, loading, unloading, shifting/transportation from site/tent. Scope of work includes Pipe earthing, jumpering/connection and modification to foundation at Site										
156	Extension of one LBS in existing 11KV RMU structure specification including grouting, loading, unloading, shifting/transportation from site/tent. Scope of work includes earthing, jumpering/connection and construction / modification of foundation	2	EA								
157	Supply & Installation of HT Danger Board as per TP Central Orissa Distribution Ltd. specification	400	No.								
158	Transportation of various items from TPCODL store/site to other site or vice versa in TPCODL operational area - Truck with labours as required (price per Km). Scope of work also include loading and unloading of materials including heavy items like HT Panel, Transformer, Cable Drum, LT Board where loading, unloading is to be done with crane and crane will be paid separately .Transport	100	MT/KM								



**TP CENTRAL ODISHA DISTRIBUTION LIMITED**  
(A Tata Power & Odisha Govt. joint venture)  
2nd Floor, IDCO Tower, Janpath Bhubaneshwar, Odisha 751022

NIT No.: TPCODL/P&S/72/2020-21

	charges upto 50KM Per Metric Ton@Rs 16/KM										
159	Installation of Fire Extinguisher (5kG DCP) by means of proper hooks clamps etc. as required including providing of grouting material (cement etc.) and painting of hooks/clamps. Scope exclude supply of hook/clamp	40	No.								
160	Painting of Pole In Black & Yellow Strips/Zebra as per TP Central Orissa Distribution Ltd. specifications and indexing/numbering of Poles as per GIS format, scope also include site survey for GIS indexing and supply of ISI Marked good quality paint. (this item shall be paid for old poles only and where this not mentioned in scope)	88	No.								
161	Installation of 11KV CTPT Unit with all connection & Earthing as per TPCODL Drawing	5	No								
<b>Total All Inclusive Price</b>											





**TP CENTRAL ODISHA DISTRIBUTION LIMITED**  
(A Tata Power & Odisha Govt. joint venture)  
2nd Floor, IDCO Tower, Janpath Bhubaneshwar, Odisha 751022

NIT No.: TPCODL/P&S/72/2020-21

**Lot-5- Schedule for Items for Cuttack – CDD-I & Cuttack CDD-II Division**

Sr No	Item Description	Qty	Unit	HSN /SAC Code	Unit Ex-Work Price (Rs./Unit)	GST (Rs/Unit)	Other Taxes and Duties (Rs/Unit)	Freight & Insurance Charges (Rs/Unit)	GST on Freight & Insurance Charges (Rs/Unit)	All Inclusive Unit Rate (Rs.)	Total All Inclusive Value (Rs.)
1	Supply of 150x150mm RS Joist Pole ( 11mtr )	4	No								
2	Supply of 150x150mm RS Joist Pole ( 13mtr )	2	No.								
3	9 mtr. long 116X100 RS Joist Pole(23.0Kg per Meter)	2	No.								
4	9 mtr. long 300 Kg. PSC Pole	3	No.								
5	Supply of 11 KV V cross Arm (10.2 K.g. each )	48	No.								
6	Supply of Top bracket 75x40mm MS channel ( 1.3kg each)for 11KV	48	No.								
7	Supply of Back Clamp for V cross Arm 1.70Kg each For 11KV pole	144	Pair								
8	Supply of 11 K.V.GI Pin	144	No.								
9	Supply of 11 K.V. Pin Insulator polymer	144	No.								
10	Supply of 11 K.V. H.W. Fitting (B & S)	86	No.								
11	Supply of 11 K.V. polymer Insulator (B & S) Double Disc 70KN	518	No.								
12	Supply of H.T. Stay set (Complete ) for 11KV	29	Set								
13	Supply of H.T. Stay Insulator for 11KV pole	29	No.								





**TP CENTRAL ODISHA DISTRIBUTION LIMITED**  
(A Tata Power & Odisha Govt. joint venture)  
2nd Floor, IDCO Tower, Janpath Bhubaneshwar, Odisha 751022

NIT No.: TPCODL/P&S/72/2020-21

29	Supply of 11KV AB Switch 3 Pole (400 Amp.)	2.4	Set								
30	Supply of 11KV HG Fuse 3 Pole (400 Amp.)	20	No.								
31	Supply of 11 KV L.A. 12KV-10KA	60	No.								
32	Supply of Pressure Channel 100 x 50 x 6mm MS channel each 2.8 mtr. Long( 9.2 K.g. per mtr.)X2 Nos ( Per Transformer H pole - 51.52Kg)	1030.4	Kg								
33	Supply of Transformer mounting channel 100 x 50 x 6mm MS channel each 2.8 mtr. Long( 9.2 K.g. per mtr.)X2 Nos (Per Transformer H pole -51.52Kg)	1030.4	Kg								
34	Supply of MS Angle for mounting AB Swith & HG .Channel size 75x40x6 -2.8 mtr.long, 4 nos.(6.8K.g. per mtr.)-76.16Kg per H-Pole	1523.2	Kg								
35	Supply of MS Angle for Cantilever channel for supporting AB Switch arm, Channel size 75x40x6-1 mtr. Long, 2 nos.(6.8 K.g. per mtr.) - 13.6Kg per H -Pole	272	Kg								
36	Supply of MS Angle for Cantilever channel for supporting HG Fuse . Channel size 50 x 50 x 6 mm MS Angel (1.0 mtrs. Long 2 nos.)4.5K.g. per mtr. (9Kg per TRF H Pole)	180	Kg								



**TP CENTRAL ODISHA DISTRIBUTION LIMITED**  
(A Tata Power & Odisha Govt. joint venture)  
2nd Floor, IDCO Tower, Janpath Bhubaneshwar, Odisha 751022

NIT No.: TPCODL/P&S/72/2020-21

37	Supply of MS Angle for Cantilever arrangement for AB Switch & HG Fuse. Channel size 50 x 50 x 6 -2 mtr .each 2 nos.(4.5 K.g. per mtr.) ( 18K.g. per TRF H pole)	360	Kg																
38	Supply of MS Angle for Transformer belting. Angle size 50 x 50 x 6 mm - 2.8 mtr. Long 2 nos.(4.5 K.g. per mtr.) with side angel ( Total 7 mtr.)(31.5Kg per TRF H Pole)	630	Kg																
39	Supply of MS Angle for mounting LT distribution Box 50 x 50 x 6 mm MS Angel -2.5 mtrs. each Long 2 nos.( 4.5 Kg per mtr.)(22.5Kg per TRF H Pole)	450	Kg																
40	Supply of L.T. Distribution box including Kit Kat fuse with MCCB for 25KVA S/S ( As pre CESU specification)	10	No.																
41	Supply of 3 1/2C x 35mm <sup>2</sup> PVC Cable for 25KVA TFR.	150	Mtr																
42	Supply of L.T. Distribution box with MCCB, Aluminium Busbar for 2bay with Kit Kat fuse for 100KVA S/S	4	No.																
43	Supply of 3 1/2C x 150mm <sup>2</sup> PVC Cable for 100 KVA TFR	6	Mtr																
44	Supply of L.T. Distribution box with MCCB, Aluminium Busbar for 3bay with Kit Kat fuse for 250KVA S/S	2	No.																



**TP CENTRAL ODISHA DISTRIBUTION LIMITED**  
(A Tata Power & Odisha Govt. joint venture)  
2nd Floor, IDCO Tower, Janpath Bhubaneshwar, Odisha 751022

NIT No.: TPCODL/P&S/72/2020-21

45	Supply of 3 1/2C x 300mm <sup>2</sup> PVC Cable for 500 KVA TFR I/C	6	Mtr								
46	Supply of Concrete slab for base place size 2ftx2ftx2" thickness for each PSC pole	79	No.								
47	Supply of LT Stay set Complete	19	Set								
48	Supply of 7/12 SWG Stay Wire	192	Kg								
49	Supply of LT Stay clamp (1.4 K.g./ Pair )	19	pair								
50	Supply of LT Stay Insulator	19	No.								
51	Supply of Dead end clamp	24	No.								
52	Supply of Suspension clamp with I-Hook	72	No.								
53	Supply of Strain fittings	19	No.								
54	Supply of Guy grip Dead end for Pole	19	No.								
55	Supply of Nuts and Bolts	57.6	Kg								
56	Supply Earthing Coil each 5th pole to earth	17	No.								
57	Supply of AB Cable( 3 x50 + 1x35mm <sup>2</sup> )	0.1	Km								
58	Supply of AB Cable( 3 x35 + 1x25mm <sup>2</sup> )	1	Km								
59	Supply of AB Cable( 3 x50 + 1x35mm <sup>2</sup> +1X16mm <sup>2</sup> )	0.1	Km								
60	Supply of AB Cable( 3 x95 + 1x70mm <sup>2</sup> +1X16mm <sup>2</sup> )	0.1	Km								
61	Supply of 1.1KV, 4C, 240Sqmm for XLPE Cable, AL,ARM	50	Mtr.								
62	Supply of 1.1KV, 4C, 300Sqmm for XLPE Cable,AL,ARM	50	No.								





**TP CENTRAL ODISHA DISTRIBUTION LIMITED**  
(A Tata Power & Odisha Govt. joint venture)  
2nd Floor, IDCO Tower, Janpath Bhubaneshwar, Odisha 751022

NIT No.: TPCODL/P&S/72/2020-21

75	Supply 3CX 300Sqmm,11KV Indoor Termination Kit	2	No.								
76	Supply 3CX 400Sqmm,11KV Indoor Termination Kit	2	No.								
77	Supply 3CX 120Sqmm,11KV Indoor Termination Kit	2	No.								
78	Supply 3CX 185Sqmm,11KV Indoor Termination Kit	2	No.								
79	Supply 3CX 95Sqmm,11KV Indoor Termination Kit	2	No.								
80	Supply 3CX 400Sqmm,11KV Outdoor Termination Kit	2	No.								
81	Supply 3CX 300Sqmm,11KV Outdoor Termination Kit	2	No.								
82	Supply 3CX 185Sqmm,11KV Outdoor Termination Kit	2	No.								
83	Supply 3CX 120Sqmm,11KV Outdoor Termination Kit	2	No.								
84	3P 4 W 11 KV CT PT Combined Metering Unit Class of Accuracy 0.5 with CTR 20/5 A, with burden 15VA, PT with Burden 50VA	4	No								
85	Supply of 4C X 4Sqmm AL PVC Service cable un Arm for releasing 1PH	36720	Mtr								
86	Supply 3.5C * 35Sqmm LT PVC Cable Un armoured	12240	Mtr								
87	Supply 3.5C * 50qmm LT PVC Cable Un armoured	4896	Mtr								
88	Supply 3.5C * 95Sqmm LT PVC Cable Un armoured	4896	Mtr								







**TP CENTRAL ODISHA DISTRIBUTION LIMITED**  
(A Tata Power & Odisha Govt. joint venture)  
2nd Floor, IDCO Tower, Janpath Bhubaneshwar, Odisha 751022

NIT No.: TPCODL/P&S/72/2020-21

	using 40mm BHG metal with all labor and material except stay set , stay wire , stay insulator .										
102	Installation of Earthing of Support ( Coil Type )	88	No.								
103	Installation of Earth Pit, Charcoal, Salt etc. including construction of earthing chamber (Size: 2'x2') and RCC slab cover	100	No.								
104	Stringing of 80-100mm <sup>2</sup> AAAC	2.4	KM								
105	Painting of RS Joist Pole with fittings 2 coats of Al paint over a coat of red oxide primer including all Tools & Tackle	88	No.								
106	Installation, Testing and Commissioning of 11/0.4kV, 25kVA 3-Phase Distribution Transformer on existing structure as per TP Central Orissa Distribution Ltd. specification including loading, unloading, shifting/transportation from Division store to site /tent. Scope of work includes, jumpering/connection at HT and LT side , including minor site modification as per the TPCODL Standard Excluding Earthing	10	EA								
107	Installation, Testing and Commissioning of 11/0.4kV, 63kVA 3-Phase Distribution Transformer on existing structure	4	EA								



**TP CENTRAL ODISHA DISTRIBUTION LIMITED**  
(A Tata Power & Odisha Govt. joint venture)  
2nd Floor, IDCO Tower, Janpath Bhubaneshwar, Odisha 751022

NIT No.: TPCODL/P&S/72/2020-21

	as per TP Central Orissa Distribution Ltd. specification including loading, unloading, shifting/transportation from Division store to site /tent. Scope of work includes, jumpering/connection at HT and LT side , including minor site modification as per the TPCODL Standard Excluding Earthing									
108	Installation, Testing and Commissioning of 11/0.4kV, 100kVA 3-Phase Distribution Transformer on existing structure as per TP Central Orissa Distribution Ltd. specification including loading, unloading, shifting/transportation from Division store to site /tent. Scope of work includes, jumpering/connection at HT and LT side , including minor site modification as per the TPCODL Standard Excluding Earthing	4	EA							
109	Installation, Testing and Commissioning of 11/0.4kV, 250kVA 3-Phase Distribution Transformer on existing structure as per TP Central Orissa Distribution Ltd. specification including loading, unloading, shifting/transportation from site /tent. Scope of work includes	2	EA							



**TP CENTRAL ODISHA DISTRIBUTION LIMITED**  
(A Tata Power & Odisha Govt. joint venture)  
2nd Floor, IDCO Tower, Janpath Bhubaneshwar, Odisha 751022

NIT No.: TPCODL/P&S/72/2020-21

	earthing, jumpering/connection at HT and LT side as per the TPCODL Standard											
110	Installation of Outdoor Type Distribution Box with 40A MCCB with O/G for 11/0.4kV,25kVA Three Phase Transformer as per TP Central Orissa Distribution Ltd. specification	10	No									
111	Installation of Outdoor Type Distribution Box with 100A MCCB with O/G for 11/0.4kV,63kVA Three Phase Transformer as per TP Central Orissa Distribution Ltd. specification	4	No									
112	Installation of Outdoor Type Distribution Box (BOX DIST.WITH 160A 35KA TP MCCB 6 O/G) for 100KVA TRF	4	No									
113	Installation testing and commissioning of LT ACB 400 Amps with enclosure for 11/0.4KV 250KVA Threephase Transformer	2	No									
114	Installation of Outdoor Type Distribution Box(BOX DIST.WITH 500A 50KA TP MCCB 5 O/G) with MCCB for 11/0.4kV,250kVA Three Phase Transformer on existing structure as per TP Central Orissa Distribution Ltd. Specification	2	No									
115	Plinth for TFR 6ft hight (below GL2ft)x5ftx5ft	6	No									



**TP CENTRAL ODISHA DISTRIBUTION LIMITED**  
(A Tata Power & Odisha Govt. joint venture)  
2nd Floor, IDCO Tower, Janpath Bhubaneshwar, Odisha 751022

NIT No.: TPCODL/P&S/72/2020-21

116	Plinth for L.T. Distribution box 6ft high (below GL2ft)x5ftx5ft	2	No								
117	Installation of GI barbed wire anticlimbing device 2 Kg. Per support	176	Kg								
118	Installation of different size MS Channel for 50 S/S	5440	Kg								
119	Installation of different size MS Channel for DP in 6KM line	945.6	Kg								
120	Supply of GI Nut , Bolt & Washer of different sizes For line with DP for 6KM Line (70KG PER KM LINE)	168	Kg								
121	Supply of GI Nut , Bolt & Washer of different sizes For 50S/S ( 36KG Per s/s)	720	Kg								
122	Painting of RS Joist	88	No								
123	Dismantling of RS Joist pole(150x150mm/Rail pole) & return back to section store	8	No								
124	Dismantling of RS Joist pole(116x100mm)	8	No								
125	Dismantling of PSC pole (9mtr)	8	No								
126	Dismantling of 11KV 'V' Cross arm	8	No								
127	Dismantling of 11KV GI pin with insulator	24	No								
128	Dismantling of 11KV Disc insulator with HW Fitting	24	No								
129	Dismantling of MS Channel from 11KV Pole / DP	40	Kg								
130	Dismantling of 55mm <sup>2</sup> AAA Conductor	0.2	KM								



**TP CENTRAL ODISHA DISTRIBUTION LIMITED**  
(A Tata Power & Odisha Govt. joint venture)  
2nd Floor, IDCO Tower, Janpath Bhubaneshwar, Odisha 751022

NIT No.: TPCODL/P&S/72/2020-21

131	Dismantling of 80mm <sup>2</sup> AAA Conductor	0.2	KM								
132	Dismantling of 100mm <sup>2</sup> AAA Conductor	0.2	KM								
133	Sundries for survey tree cutting, small size nut bolt, Aluminium Binding wire / tape & Danger Board 4 Nos. etc. Line length of 1KM	2.4	LS								
134	Sundries for survey tree cutting, small size nut bolt, Aluminium. Binding wire / tape & Danger Board 4 Nos. etc. Substation upto 250KVA	20	LS								
135	Installation of Dead end clamp on LT Pole	24	No.								
136	Installation of Suspension clamp with I-Hook on LT Pole	72	No.								
137	Installation of Strain fittings on LT pole	19	No.								
138	Installation of Guy grip Dead end for LT Pole	19	No.								
139	Installation of Earthing Coil TO POLE	17	No.								
140	Laying / stringing of AB Cable( 3 x50 + 1x35mm <sup>2</sup> )	2400	Mtr.								
141	Laying / Stringing of AB Cable( 3 x35 + 1x25mm <sup>2</sup> )	2400	Mtr.								
142	Laying / Stringing of AB Cable( 3 x50 + 1x35mm <sup>2</sup> +1X16mm <sup>2</sup> )	2400	Mtr.								
143	Laying / Stringing of AB Cable( 3 x95 + 1x70mm <sup>2</sup> +1X16mm <sup>2</sup> )	2400	Mtr.								



**TP CENTRAL ODISHA DISTRIBUTION LIMITED**  
(A Tata Power & Odisha Govt. joint venture)  
2nd Floor, IDCO Tower, Janpath Bhubaneshwar, Odisha 751022

NIT No.: TPCODL/P&S/72/2020-21

144	Laying of Service cable 4sqmm x 2C	2	Mtr.								
145	Laying of 1.1KV 3.5C, 35Sqmm AL XLPE Cable	12240	Mtr.								
146	Laying of 1.1KV 3.5C, 150SqmmAL XLPE Cable	4896	Mtr.								
147	Laying of 1.1KV 4C, 240Sqmm AL XLPE Cable	4896	Mtr.								
148	Laying of 1.1KV 3.5C, 300Sqmm AL XLPE Cable	50	Mtr.								
149	Laying & EXCAVATION (1M Depth * 0.875M Width) of 11kV Armoured XLPE AL Cable 3CX95 sqmm/ 3CX120 sqmm in S/Sth. Trench/Tray as per TP Central Orissa Distribution Ltd. specification including testing of cable. Scope of work exclude fixing of Tray.BA will provide support during joint making by OEM of joint kit,no separate payment will be paid to BA for this support by BA	50	Mtr.								
150	Laying & Excavation (1M Depth * 0.875M) of 11kV Armoured XLPE AL Cable 3CX400/ 3X300 sqmm in S/Sth. Trench/Tray as per TP Central Orissa Distribution Ltd. specification including testing of cable. Scope of work exclude fixing of Tray.BA will provide support during joint making by	50	Mtr.								



**TP CENTRAL ODISHA DISTRIBUTION LIMITED**  
(A Tata Power & Odisha Govt. joint venture)  
2nd Floor, IDCO Tower, Janpath Bhubaneshwar, Odisha 751022

NIT No.: TPCODL/P&S/72/2020-21

	OEM of joint kit, no separate payment will be paid to BA for this support by BA										
151	Jointing of I/D or O/D of HT (11KV) UGC & including all related work and Approved Joints	2	No.								
152	Indoor / outdoor Termination of 11 kV Armoured XLPE, AL Cable 3CX95 sqmm, 120Sqmm, 185Sqmm, 300SQMM, 400SQMM including consumable	2	EA								
153	Construction of 11KV RMU Plinth with Brick, Mortar, 12 mm cement plaster and painting with enamel paint.	2	EA								
154	Installation, Testing and Commissioning of 11kV 3-way Ring Main Unit on existing structure/foundation as per TP Central Orissa Distribution Ltd. specification including grouting, loading, unloading, shifting/transportation from site/tent. Scope of work includes pipe earthing, jumpering/connection and modification to foundation at Site	2	EA								
155	Installation, Testing and Commissioning of 1.1kV Feeder pillar with new structure/foundation as per TP Central Orissa Distribution Ltd. specification	2	EA								



**TP CENTRAL ODISHA DISTRIBUTION LIMITED**  
(A Tata Power & Odisha Govt. joint venture)  
2nd Floor, IDCO Tower, Janpath Bhubaneshwar, Odisha 751022

NIT No.: TPCODL/P&S/72/2020-21

	including grouting, loading, unloading, shifting/transportation from site/tent. Scope of work includes Pipe earthing, jumpering/connection and modification to foundation at Site										
156	Extension of one LBS in existing 11KV RMU structure specification including grouting, loading, unloading, shifting/transportation from site/tent. Scope of work includes earthing, jumpering/connection and construction / modification of foundation	2	EA								
157	Supply & Installation of HT Danger Board as per TP Central Orissa Distribution Ltd. specification	400	No.								
158	Transportation of various items from TPCODL store/site to other site or vice versa in TPCODL operational area - Truck with labours as required (price per Km). Scope of work also include loading and unloading of materials including heavy items like HT Panel, Transformer, Cable Drum, LT Board where loading, unloading is to be done with crane and crane will be paid separately .Transport	100	MT/KM								





**TP CENTRAL ODISHA DISTRIBUTION LIMITED**  
(A Tata Power & Odisha Govt. joint venture)  
2nd Floor, IDCO Tower, Janpath Bhubaneshwar, Odisha 751022

NIT No.: TPCODL/P&S/72/2020-21

	charges upto 50KM Per Metric Ton@Rs 16/KM										
159	Installation of Fire Extinguisher (5kG DCP) by means of proper hooks clamps etc. as required including providing of grouting material (cement etc.) and painting of hooks/clamps. Scope exclude supply of hook/clamp	40	No.								
160	Painting of Pole In Black & Yellow Strips/Zebra as per TP Central Orissa Distribution Ltd. specifications and indexing/numbering of Poles as per GIS format, scope also include site survey for GIS indexing and supply of ISI Marked good quality paint. (this item shall be paid for old poles only and where this not mentioned in scope)	88	No.								
161	Installation of 11KV CTPT Unit with all connection & Earthing as per TPCODL Drawing	5	No								
<b>Total All Inclusive Price</b>											



**TP CENTRAL ODISHA DISTRIBUTION LIMITED**  
(A Tata Power & Odisha Govt. joint venture)  
2nd Floor, IDCO Tower, Janpath Bhubaneshwar, Odisha 751022

NIT No.: TPCODL/P&S/72/2020-21

**Lot-6- Schedule for Items for Cuttack – SED & Cuttack CED Division**

Sr No	Item Description	Qty	Unit	HSN /SAC Code	Unit Ex-Work Price (Rs./Unit)	GST (Rs/Unit)	Other Taxes and Duties (Rs/Unit)	Freight & Insurance Charges (Rs/Unit)	GST on Freight & Insurance Charges (Rs/Unit)	All Inclusive Unit Rate (Rs.)	Total All Inclusive Value (Rs.)
1	Supply of 150x150mm RS Joist Pole ( 11mtr )	4	No								
2	Supply of 150x150mm RS Joist Pole ( 13mtr )	2	No.								
3	9 mtr. long 116X100 RS Joist Pole(23.0Kg per Meter)	2	No.								
4	9 mtr. long 300 Kg. PSC Pole	3	No.								
5	Supply of 11 KV V cross Arm (10.2 K.g. each )	48	No.								
6	Supply of Top bracket 75x40mm MS channel ( 1.3kg each)for 11KV	48	No.								
7	Supply of Back Clamp for V cross Arm 1.70Kg each For 11KV pole	144	Pair								
8	Supply of 11 K.V.GI Pin	144	No.								
9	Supply of 11 K.V. Pin Insulator polymer	144	No.								
10	Supply of 11 K.V. H.W. Fitting (B & S)	86	No.								
11	Supply of 11 K.V. polymer Insulator (B & S) Double Disc 70KN	518	No.								
12	Supply of H.T. Stay set (Complete ) for 11KV	29	Set								





**TP CENTRAL ODISHA DISTRIBUTION LIMITED**  
(A Tata Power & Odisha Govt. joint venture)  
2nd Floor, IDCO Tower, Janpath Bhubaneshwar, Odisha 751022

NIT No.: TPCODL/P&S/72/2020-21

28	Supply of 11KV AB Switch 3 Pole (200 Amp.)	20	Set								
29	Supply of 11KV AB Switch 3 Pole (400 Amp.)	2.4	Set								
30	Supply of 11KV HG Fuse 3 Pole (400 Amp.)	20	No.								
31	Supply of 11 KV L.A. 12KV-10KA	60	No.								
32	Supply of Pressure Channel 100 x 50 x 6mm MS channel each 2.8 mtr. Long( 9.2 K.g. per mtr.)X2 Nos ( Per Transformer H pole - 51.52Kg)	1030.4	Kg								
33	Supply of Transformer mounting channel 100 x 50 x 6mm MS channel each 2.8 mtr. Long( 9.2 K.g. per mtr.)X2 Nos (Per Transformer H pole -51.52Kg)	1030.4	Kg								
34	Supply of MS Angle for mounting AB Swith & HG .Channel size 75x40x6 -2.8 mtr.long, 4 nos.(6.8K.g. per mtr.)-76.16Kg per H-Pole	1523.2	Kg								
35	Supply of MS Angle for Cantilever channel for supporting AB Switch arm, Channel size 75x40x6-1 mtr. Long, 2 nos.(6.8 K.g. per mtr.) - 13.6Kg per H -Pole	272	Kg								
36	Supply of MS Angle for Cantilever channel for supporting HG Fuse . Channel size 50 x 50 x 6 mm MS Angel (1.0 mtrs. Long 2	180	Kg								



**TP CENTRAL ODISHA DISTRIBUTION LIMITED**  
(A Tata Power & Odisha Govt. joint venture)  
2nd Floor, IDCO Tower, Janpath Bhubaneshwar, Odisha 751022

NIT No.: TPCODL/P&S/72/2020-21

	nos.)4.5K.g. per mtr. (9Kg per TRF H Pole)										
37	Supply of MS Angle for Cantilever arrangement for AB Switch & HG Fuse. Channel size 50 x 50 x 6 -2 mtr .each 2 nos.(4.5 K.g. per mtr.) ( 18K.g. per TRF H pole)	360	Kg								
38	Supply of MS Angle for Transformer belting. Angle size 50 x 50 x 6 mm - 2.8 mtr. Long 2 nos.(4.5 K.g. per mtr.) with side angel ( Total 7 mtr.)(31.5Kg per TRF H Pole)	630	Kg								
39	Supply of MS Angle for mounting LT distribution Box 50 x 50 x 6 mm MS Angel -2.5 mtrs. each Long 2 nos.( 4.5 Kg per mtr.)(22.5Kg per TRF H Pole)	450	Kg								
40	Supply of L.T. Distribution box including Kit Kat fuse with MCCB for 25KVA S/S ( As pre CESU specification)	10	No.								
41	Supply of 3 1/2C x 35mm <sup>2</sup> PVC Cable for 25KVA TFR.	150	Mtr								
42	Supply of L.T. Distribution box with MCCB, Aluminium Busbar for 2bay with Kit Kat fuse for 100KVA S/S	4	No.								
43	Supply of 3 1/2C x 150mm <sup>2</sup> PVC Cable for 100 KVA TFR	6	Mtr								
44	Supply of L.T. Distribution box with MCCB, Aluminium Busbar for	2	No.								











**TP CENTRAL ODISHA DISTRIBUTION LIMITED**  
(A Tata Power & Odisha Govt. joint venture)  
2nd Floor, IDCO Tower, Janpath Bhubaneshwar, Odisha 751022

NIT No.: TPCODL/P&S/72/2020-21

88	Supply 3.5C * 95Sqmm LT PVC Cable Un armoured	4896	Mtr								
89	Concreting of support C.C - 1:4:8 using 40mm BHG metal size - 5'x2'x2' = 20CFT = 0.570Cum Padding 900x600x150mm = 0.081 0.651Cum	88	No's								
90	Coupling of support section 15"x15" ( 3.9Cft) height 2'-6" ( 1' - 6" above G.L & 1' - 0" below G.L ) in C.C 1:2:4 using 12mm BHG metal & curing for 5 days	88	Nos								
91	Erection of RS Joist pole(150x150mm) 13mtr.	88	No.								
92	Erection of RS Joist pole(150x150mm) 11mtr.	88	No.								
93	Erection of 9mtr. long 300kg PSC pole	40	No.								
94	Installation of 11 KV V cross Arm (10.2 Kg each )	48	No.								
95	Installation of Top bracket 75x40mm MS channel ( 1.3kg each)/	48	No.								
96	Installation of Back Clamp for V cross Arm 1.70Kg each	48	Pair								
97	Installation of 11 K.V.GI Pin	144	No.								
98	Installation of 11 K.V. Pin Insulator	144	No.								
99	Installation of 11 K.V. DISC Insulator (B & S) Double Disc 70KN With H/W Fitting	86	No.								
100	Fixing of Stay Set (Complete)	29	No								



**TP CENTRAL ODISHA DISTRIBUTION LIMITED**  
(A Tata Power & Odisha Govt. joint venture)  
2nd Floor, IDCO Tower, Janpath Bhubaneshwar, Odisha 751022

NIT No.: TPCODL/P&S/72/2020-21

101	Fixing of stay set with 0.5Cum cement concrete foundation 1:3:6 size ( 900mmx600mmx900mm) using 40mm BHG metal with all labor and material except stay set , stay wire , stay insulator .	29	No.								
102	Installation of Earthing of Support ( Coil Type )	88	No.								
103	Installation of Earth Pit, Charcoal, Salt etc. including construction of earthing chamber (Size: 2'x2') and RCC slab cover	100	No.								
104	Stringing of 80-100mm <sup>2</sup> AAAC	2.4	KM								
105	Painting of RS Joist Pole with fittings 2 coats of Al paint over a coat of red oxide primer including all Tools & Tackle	88	No.								
106	Installation, Testing and Commissioning of 11/0.4kV, 25kVA 3-Phase Distribution Transformer on existing structure as per TP Central Orissa Distribution Ltd. specification including loading, unloading, shifting/transportation from Division store to site /tent. Scope of work includes, jumpering/connection at HT and LT side , including minor site modification as per the TPCODL Standard Excluding Earthing	10	EA								



**TP CENTRAL ODISHA DISTRIBUTION LIMITED**  
(A Tata Power & Odisha Govt. joint venture)  
2nd Floor, IDCO Tower, Janpath Bhubaneshwar, Odisha 751022

NIT No.: TPCODL/P&S/72/2020-21

107	Installation, Testing and Commissioning of 11/0.4kV, 63kVA 3-Phase Distribution Transformer on existing structure as per TP Central Orissa Distribution Ltd. specification including loading, unloading, shifting/transportation from Division store to site /tent. Scope of work includes, jumpering/connection at HT and LT side , including minor site modification as per the TPCODL Standard Excluding Earthing	4	EA								
108	Installation, Testing and Commissioning of 11/0.4kV, 100kVA 3-Phase Distribution Transformer on existing structure as per TP Central Orissa Distribution Ltd. specification including loading, unloading, shifting/transportation from Division store to site /tent. Scope of work includes, jumpering/connection at HT and LT side , including minor site modification as per the TPCODL Standard Excluding Earthing	4	EA								
109	Installation, Testing and Commissioning of 11/0.4kV, 250kVA 3-Phase Distribution Transformer on existing structure as per TP Central Orissa	2	EA								



**TP CENTRAL ODISHA DISTRIBUTION LIMITED**  
(A Tata Power & Odisha Govt. joint venture)  
2nd Floor, IDCO Tower, Janpath Bhubaneshwar, Odisha 751022

NIT No.: TPCODL/P&S/72/2020-21

	Distribution Ltd. specification including loading, unloading, shifting/transportation from site /tent. Scope of work includes earthing, jumpering/connection at HT and LT side as per the TPCODL Standard										
110	Installation of Outdoor Type Distribution Box with 40A MCCB with O/G for 11/0.4kV,25kVA Three Phase Transformer as per TP Central Orissa Distribution Ltd. specification	10	No								
111	Installation of Outdoor Type Distribution Box with 100A MCCB with O/G for 11/0.4kV,63kVA Three Phase Transformer as per TP Central Orissa Distribution Ltd. specification	4	No								
112	Installation of Outdoor Type Distribution Box (BOX DIST.WITH 160A 35KA TP MCCB 6 O/G) for 100KVA TRF	4	No								
113	Installation testing and commissioning of LT ACB 400 Amps with enclosure for 11/0.4KV 250KVA Threephase Transformer	2	No								
114	Installation of Outdoor Type Distribution Box(BOX DIST.WITH 500A 50KA TP MCCB 5 O/G) with MCCB for 11/0.4kV,250kVA Three Phase Transformer on existing	2	No								





**TP CENTRAL ODISHA DISTRIBUTION LIMITED**  
(A Tata Power & Odisha Govt. joint venture)  
2nd Floor, IDCO Tower, Janpath Bhubaneshwar, Odisha 751022

NIT No.: TPCODL/P&S/72/2020-21

129	Dismantling of MS Channel from 11KV Pole / DP	40	Kg								
130	Dismantling of 55mm <sup>2</sup> AAA Conductor	0.2	KM								
131	Dismantling of 80mm <sup>2</sup> AAA Conductor	0.2	KM								
132	Dismantling of 100mm <sup>2</sup> AAA Conductor	0.2	KM								
133	Sundries for survey tree cutting, small size nut bolt, Aluminium Binding wire / tape & Danger Board 4 Nos. etc. Line length of 1KM	2.4	LS								
134	Sundries for survey tree cutting, small size nut bolt, Aluminium. Binding wire / tape & Danger Board 4 Nos. etc. Substation upto 250KVA	20	LS								
135	Installation of Dead end clamp on LT Pole	24	No.								
136	Installation of Suspension clamp with I-Hook on LT Pole	72	No.								
137	Installation of Strain fittings on LT pole	19	No.								
138	Installation of Guy grip Dead end for LT Pole	19	No.								
139	Installation of Earthing Coil TO POLE	17	No.								
140	Laying / stringing of AB Cable( 3 x50 + 1x35mm <sup>2</sup> )	2400	Mtr.								
141	Laying / Stringing of AB Cable( 3 x35 + 1x25mm <sup>2</sup> )	2400	Mtr.								



**TP CENTRAL ODISHA DISTRIBUTION LIMITED**  
(A Tata Power & Odisha Govt. joint venture)  
2nd Floor, IDCO Tower, Janpath Bhubaneshwar, Odisha 751022

NIT No.: TPCODL/P&S/72/2020-21

142	Laying / Stringing of AB Cable( 3 x50 + 1x35mm <sup>2</sup> +1X16mm <sup>2</sup> )	2400	Mtr.								
143	Laying / Stringing of AB Cable( 3 x95 + 1x70mm <sup>2</sup> +1X16mm <sup>2</sup> )	2400	Mtr.								
144	Laying of Service cable 4sqmm x 2C	2	Mtr.								
145	Laying of 1.1KV 3.5C, 35Sqmm AL XLPE Cable	12240	Mtr.								
146	Laying of 1.1KV 3.5C, 150SqmmAL XLPE Cable	4896	Mtr.								
147	Laying of 1.1KV 4C, 240Sqmm AL XLPE Cable	4896	Mtr.								
148	Laying of 1.1KV 3.5C, 300Sqmm AL XLPE Cable	50	Mtr.								
149	Laying & EXCAVATION (1M Depth * 0.875M Width) of 11kV Armoured XLPE AL Cable 3CX95 sqmm/ 3CX120 sqmm in S/Sth. Trench/Tray as per TP Central Orissa Distribution Ltd. specification including testing of cable. Scope of work exclude fixing of Tray.BA will provide support during joint making by OEM of joint kit,no seperate payment will be paid to BA for this support by BA	50	Mtr.								
150	Laying & Excavation (1M Depth * 0.875M) of 11kV Armoured XLPE AL Cable 3CX400/ 3X300 sqmm in S/Sth. Trench/Tray as per TP Central Orissa Distribution Ltd.	50	Mtr.								



**TP CENTRAL ODISHA DISTRIBUTION LIMITED**  
(A Tata Power & Odisha Govt. joint venture)  
2nd Floor, IDCO Tower, Janpath Bhubaneshwar, Odisha 751022

NIT No.: TPCODL/P&S/72/2020-21

	specification including testing of cable. Scope of work exclude fixing of Tray.BA will provide support during joint making by OEM of joint kit,no seperate payment will be paid to BA for this support by BA										
151	Jointing of I/D or O/D of HT (11KV ) UGC & icluding all related work and Approved Jointer	2	No.								
152	Indoor / outdoor Termination of 11 kV Armoured XLPE, AL Cable 3CX95 sqmm,120Sqmm, 185Sqmm, 300SQMM, 400SQMM including consumable	2	EA								
153	Construction of 11KV RMU Plinth with Brick, Mortar, 12 mm cement plaster and painting with enamel paint.	2	EA								
154	Installation, Testing and Commissioning of 11kV 3-way Ring Main Unit on existing structure/foundation as per TP Central Orissa Distribution Ltd. specification including grouting, loading, unloading, shifting/transportation from site/tent. Scope of work includes pipe earthing, jumpering/connection and modification to foundation at Site	2	EA								





**TP CENTRAL ODISHA DISTRIBUTION LIMITED**  
(A Tata Power & Odisha Govt. joint venture)  
2nd Floor, IDCO Tower, Janpath Bhubaneshwar, Odisha 751022

NIT No.: TPCODL/P&S/72/2020-21

155	Installation, Testing and Commissioning of 1.1kV Feeder pillar with new structure/foundation as per TP Central Orissa Distribution Ltd. specification including grouting, loading, unloading, shifting/transportation from site/tent. Scope of work includes Pipe earthing, jumpering/connection and modification to foundation at Site	2	EA								
156	Extension of one LBS in existing 11KV RMU structure specification including grouting, loading, unloading, shifting/transportation from site/tent. Scope of work includes earthing, jumpering/connection and construction / modification of foundation	2	EA								
157	Supply & Installation of HT Danger Board as per TP Central Orissa Distribution Ltd. specification	400	No.								
158	Transportation of various items from TPCODL store/site to other site or vice versa in TPCODL operational area - Truck with labours as required (price per Km). Scope of work also include loading and unloading of materials including heavy items like HT	100	MT/KM								



**TP CENTRAL ODISHA DISTRIBUTION LIMITED**  
(A Tata Power & Odisha Govt. joint venture)  
2nd Floor, IDCO Tower, Janpath Bhubaneshwar, Odisha 751022

NIT No.: TPCODL/P&S/72/2020-21

	Panel, Transformer, Cable Drum, LT Board where loading, unloading is to be done with crane and crane will be paid separately .Transport charges upto 50KM Per Metric Ton@Rs 16/KM										
159	Installation of Fire Extinguisher (5kG DCP) by means of proper hooks clamps etc. as required including providing of grouting material (cement etc.) and painting of hooks/clamps. Scope exclude supply of hook/clamp	40	No.								
160	Painting of Pole In Black & Yellow Strips/Zebra as per TP Central Orissa Distribution Ltd. specifications and indexing/numbering of Poles as per GIS format, scope also include site survey for GIS indexing and supply of ISI Marked good quality paint. (this item shall be paid for old poles only and where this not mentioned in scope)	88	No.								
161	Installation of 11KV CTPT Unit with all connection & Earthing as per TPCODL Drawing	5	No								
<b>Total All Inclusive Price</b>											



**TP CENTRAL ODISHA DISTRIBUTION LIMITED**  
(A Tata Power & Odisha Govt. joint venture)  
2nd Floor, IDCO Tower, Janpath Bhubaneshwar, Odisha 751022

NIT No.: TPCODL/P&S/72/2020-21

**Lot-7 Schedule for Items for DHENKANAL – DED & Cuttack- AED Division**

Sr No	Item Description	Qty	Unit	HSN /SAC Code	Unit Ex-Work Price (Rs./Unit)	GST (Rs/Unit)	Other Taxes and Duties (Rs/Unit)	Freight & Insurance Charges (Rs/Unit)	GST on Freight & Insurance Charges (Rs/Unit)	All Inclusive Unit Rate (Rs.)	Total All Inclusive Value (Rs.)
1	Supply of 150x150mm RS Joist Pole ( 11mtr )	4	No								
2	Supply of 150x150mm RS Joist Pole ( 13mtr )	2	No.								
3	9 mtr. long 116X100 RS Joist Pole(23.0Kg per Meter)	2	No.								
4	9 mtr. long 300 Kg. PSC Pole	3	No.								
5	Supply of 11 KV V cross Arm (10.2 K.g. each )	48	No.								
6	Supply of Top bracket 75x40mm MS channel ( 1.3kg each)for 11KV	48	No.								
7	Supply of Back Clamp for V cross Arm 1.70Kg each For 11KV pole	144	Pair								
8	Supply of 11 K.V.GI Pin	144	No.								
9	Supply of 11 K.V. Pin Insulator polymer	144	No.								
10	Supply of 11 K.V. H.W. Fitting (B & S)	86	No.								
11	Supply of 11 K.V. polymer Insulator (B & S) Double Disc 70KN	518	No.								
12	Supply of H.T. Stay set (Complete ) for 11KV	29	Set								





**TP CENTRAL ODISHA DISTRIBUTION LIMITED**  
(A Tata Power & Odisha Govt. joint venture)  
2nd Floor, IDCO Tower, Janpath Bhubaneshwar, Odisha 751022

NIT No.: TPCODL/P&S/72/2020-21

28	Supply of 11KV AB Switch 3 Pole (200 Amp.)	20	Set								
29	Supply of 11KV AB Switch 3 Pole (400 Amp.)	2.4	Set								
30	Supply of 11KV HG Fuse 3 Pole (400 Amp.)	20	No.								
31	Supply of 11 KV L.A. 12KV-10KA	60	No.								
32	Supply of Pressure Channel 100 x 50 x 6mm MS channel each 2.8 mtr. Long( 9.2 K.g. per mtr.)X2 Nos ( Per Transformer H pole - 51.52Kg)	1030.4	Kg								
33	Supply of Transformer mounting channel 100 x 50 x 6mm MS channel each 2.8 mtr. Long( 9.2 K.g. per mtr.)X2 Nos (Per Transformer H pole -51.52Kg)	1030.4	Kg								
34	Supply of MS Angle for mounting AB Swith & HG .Channel size 75x40x6 -2.8 mtr.long, 4 nos.(6.8K.g. per mtr.)-76.16Kg per H-Pole	1523.2	Kg								
35	Supply of MS Angle for Cantilever channel for supporting AB Switch arm, Channel size 75x40x6-1 mtr. Long, 2 nos.(6.8 K.g. per mtr.) - 13.6Kg per H -Pole	272	Kg								
36	Supply of MS Angle for Cantilever channel for supporting HG Fuse . Channel size 50 x 50 x 6 mm MS Angel (1.0 mtrs. Long 2	180	Kg								



**TP CENTRAL ODISHA DISTRIBUTION LIMITED**  
(A Tata Power & Odisha Govt. joint venture)  
2nd Floor, IDCO Tower, Janpath Bhubaneshwar, Odisha 751022

NIT No.: TPCODL/P&S/72/2020-21

	nos.)4.5K.g. per mtr. (9Kg per TRF H Pole)																			
37	Supply of MS Angle for Cantilever arrangement for AB Switch & HG Fuse. Channel size 50 x 50 x 6 -2 mtr .each 2 nos.(4.5 K.g. per mtr.) ( 18K.g. per TRF H pole)	360	Kg																	
38	Supply of MS Angle for Transformer belting. Angle size 50 x 50 x 6 mm - 2.8 mtr. Long 2 nos.(4.5 K.g. per mtr.) with side angel ( Total 7 mtr.)(31.5Kg per TRF H Pole)	630	Kg																	
39	Supply of MS Angle for mounting LT distribution Box 50 x 50 x 6 mm MS Angel -2.5 mtrs. each Long 2 nos.( 4.5 Kg per mtr.)(22.5Kg per TRF H Pole)	450	Kg																	
40	Supply of L.T. Distribution box including Kit Kat fuse with MCCB for 25KVA S/S ( As pre CESU specification)	10	No.																	
41	Supply of 3 1/2C x 35mm <sup>2</sup> PVC Cable for 25KVA TFR.	150	Mtr																	
42	Supply of L.T. Distribution box with MCCB, Aluminium Busbar for 2bay with Kit Kat fuse for 100KVA S/S	4	No.																	
43	Supply of 3 1/2C x 150mm <sup>2</sup> PVC Cable for 100 KVA TFR	6	Mtr																	
44	Supply of L.T. Distribution box with MCCB, Aluminium Busbar for	2	No.																	











**TP CENTRAL ODISHA DISTRIBUTION LIMITED**  
(A Tata Power & Odisha Govt. joint venture)  
2nd Floor, IDCO Tower, Janpath Bhubaneshwar, Odisha 751022

NIT No.: TPCODL/P&S/72/2020-21

88	Supply 3.5C * 95Sqmm LT PVC Cable Un armoured	4896	Mtr								
89	Concreting of support C.C - 1:4:8 using 40mm BHG metal size - 5'x2'x2' = 20CFT = 0.570Cum Padding 900x600x150mm = 0.081 0.651Cum	88	No's								
90	Coupling of support section 15"x15" ( 3.9Cft) height 2'-6" ( 1' - 6" above G.L & 1' - 0" below G.L ) in C.C 1:2:4 using 12mm BHG metal & curing for 5 days	88	Nos								
91	Erection of RS Joist pole(150x150mm) 13mtr.	88	No.								
92	Erection of RS Joist pole(150x150mm) 11mtr.	88	No.								
93	Erection of 9mtr. long 300kg PSC pole	40	No.								
94	Installation of 11 KV V cross Arm (10.2 Kg each )	48	No.								
95	Installation of Top bracket 75x40mm MS channel ( 1.3kg each)/	48	No.								
96	Installation of Back Clamp for V cross Arm 1.70Kg each	48	Pair								
97	Installation of 11 K.V.GI Pin	144	No.								
98	Installation of 11 K.V. Pin Insulator	144	No.								
99	Installation of 11 K.V. DISC Insulator (B & S) Double Disc 70KN With H/W Fitting	86	No.								
100	Fixing of Stay Set (Complete)	29	No								



**TP CENTRAL ODISHA DISTRIBUTION LIMITED**  
(A Tata Power & Odisha Govt. joint venture)  
2nd Floor, IDCO Tower, Janpath Bhubaneshwar, Odisha 751022

NIT No.: TPCODL/P&S/72/2020-21

101	Fixing of stay set with 0.5Cum cement concrete foundation 1:3:6 size ( 900mmx600mmx900mm) using 40mm BHG metal with all labor and material except stay set , stay wire , stay insulator .	29	No.								
102	Installation of Earthing of Support ( Coil Type )	88	No.								
103	Installation of Earth Pit, Charcoal, Salt etc. including construction of earthing chamber (Size: 2'x2') and RCC slab cover	100	No.								
104	Stringing of 80-100mm <sup>2</sup> AAAC	2.4	KM								
105	Painting of RS Joist Pole with fittings 2 coats of Al paint over a coat of red oxide primer including all Tools & Tackle	88	No.								
106	Installation, Testing and Commissioning of 11/0.4kV, 25kVA 3-Phase Distribution Transformer on existing structure as per TP Central Orissa Distribution Ltd. specification including loading, unloading, shifting/transportation from Division store to site /tent. Scope of work includes, jumpering/connection at HT and LT side , including minor site modification as per the TPCODL Standard Excluding Earthing	10	EA								



**TP CENTRAL ODISHA DISTRIBUTION LIMITED**  
(A Tata Power & Odisha Govt. joint venture)  
2nd Floor, IDCO Tower, Janpath Bhubaneshwar, Odisha 751022

NIT No.: TPCODL/P&S/72/2020-21

107	Installation, Testing and Commissioning of 11/0.4kV, 63kVA 3-Phase Distribution Transformer on existing structure as per TP Central Orissa Distribution Ltd. specification including loading, unloading, shifting/transportation from Division store to site /tent. Scope of work includes, jumpering/connection at HT and LT side , including minor site modification as per the TPCODL Standard Excluding Earthing	4	EA								
108	Installation, Testing and Commissioning of 11/0.4kV, 100kVA 3-Phase Distribution Transformer on existing structure as per TP Central Orissa Distribution Ltd. specification including loading, unloading, shifting/transportation from Division store to site /tent. Scope of work includes, jumpering/connection at HT and LT side , including minor site modification as per the TPCODL Standard Excluding Earthing	4	EA								
109	Installation, Testing and Commissioning of 11/0.4kV, 250kVA 3-Phase Distribution Transformer on existing structure as per TP Central Orissa	2	EA								



**TP CENTRAL ODISHA DISTRIBUTION LIMITED**  
(A Tata Power & Odisha Govt. joint venture)  
2nd Floor, IDCO Tower, Janpath Bhubaneshwar, Odisha 751022

NIT No.: TPCODL/P&S/72/2020-21

	Distribution Ltd. specification including loading, unloading, shifting/transportation from site /tent. Scope of work includes earthing, jumpering/connection at HT and LT side as per the TPCODL Standard										
110	Installation of Outdoor Type Distribution Box with 40A MCCB with O/G for 11/0.4kV,25kVA Three Phase Transformer as per TP Central Orissa Distribution Ltd. specification	10	No								
111	Installation of Outdoor Type Distribution Box with 100A MCCB with O/G for 11/0.4kV,63kVA Three Phase Transformer as per TP Central Orissa Distribution Ltd. specification	4	No								
112	Installation of Outdoor Type Distribution Box (BOX DIST.WITH 160A 35KA TP MCCB 6 O/G) for 100KVA TRF	4	No								
113	Installation testing and commissioning of LT ACB 400 Amps with enclosure for 11/0.4KV 250KVA Threephase Transformer	2	No								
114	Installation of Outdoor Type Distribution Box(BOX DIST.WITH 500A 50KA TP MCCB 5 O/G) with MCCB for 11/0.4kV,250kVA Three Phase Transformer on existing	2	No								





**TP CENTRAL ODISHA DISTRIBUTION LIMITED**  
(A Tata Power & Odisha Govt. joint venture)  
2nd Floor, IDCO Tower, Janpath Bhubaneshwar, Odisha 751022

NIT No.: TPCODL/P&S/72/2020-21

129	Dismantling of MS Channel from 11KV Pole / DP	40	Kg								
130	Dismantling of 55mm <sup>2</sup> AAA Conductor	0.2	KM								
131	Dismantling of 80mm <sup>2</sup> AAA Conductor	0.2	KM								
132	Dismantling of 100mm <sup>2</sup> AAA Conductor	0.2	KM								
133	Sundries for survey tree cutting, small size nut bolt, Aluminium Binding wire / tape & Danger Board 4 Nos. etc. Line length of 1KM	2.4	LS								
134	Sundries for survey tree cutting, small size nut bolt, Aluminium. Binding wire / tape & Danger Board 4 Nos. etc. Substation upto 250KVA	20	LS								
135	Installation of Dead end clamp on LT Pole	24	No.								
136	Installation of Suspension clamp with I-Hook on LT Pole	72	No.								
137	Installation of Strain fittings on LT pole	19	No.								
138	Installation of Guy grip Dead end for LT Pole	19	No.								
139	Installation of Earthing Coil TO POLE	17	No.								
140	Laying / stringing of AB Cable( 3 x50 + 1x35mm <sup>2</sup> )	2400	Mtr.								
141	Laying / Stringing of AB Cable( 3 x35 + 1x25mm <sup>2</sup> )	2400	Mtr.								



**TP CENTRAL ODISHA DISTRIBUTION LIMITED**  
(A Tata Power & Odisha Govt. joint venture)  
2nd Floor, IDCO Tower, Janpath Bhubaneshwar, Odisha 751022

NIT No.: TPCODL/P&S/72/2020-21

142	Laying / Stringing of AB Cable( 3 x50 + 1x35mm <sup>2</sup> +1X16mm <sup>2</sup> )	2400	Mtr.								
143	Laying / Stringing of AB Cable( 3 x95 + 1x70mm <sup>2</sup> +1X16mm <sup>2</sup> )	2400	Mtr.								
144	Laying of Service cable 4sqmm x 2C	2	Mtr.								
145	Laying of 1.1KV 3.5C, 35Sqmm AL XLPE Cable	12240	Mtr.								
146	Laying of 1.1KV 3.5C, 150SqmmAL XLPE Cable	4896	Mtr.								
147	Laying of 1.1KV 4C, 240Sqmm AL XLPE Cable	4896	Mtr.								
148	Laying of 1.1KV 3.5C, 300Sqmm AL XLPE Cable	50	Mtr.								
149	Laying & EXCAVATION (1M Depth * 0.875M Width) of 11kV Armoured XLPE AL Cable 3CX95 sqmm/ 3CX120 sqmm in S/Sth. Trench/Tray as per TP Central Orissa Distribution Ltd. specification including testing of cable. Scope of work exclude fixing of Tray.BA will provide support during joint making by OEM of joint kit,no seperate payment will be paid to BA for this support by BA	50	Mtr.								
150	Laying & Excavation (1M Depth * 0.875M) of 11kV Armoured XLPE AL Cable 3CX400/ 3X300 sqmm in S/Sth. Trench/Tray as per TP Central Orissa Distribution Ltd.	50	Mtr.								





**TP CENTRAL ODISHA DISTRIBUTION LIMITED**  
(A Tata Power & Odisha Govt. joint venture)  
2nd Floor, IDCO Tower, Janpath Bhubaneshwar, Odisha 751022

NIT No.: TPCODL/P&S/72/2020-21

	specification including testing of cable. Scope of work exclude fixing of Tray.BA will provide support during joint making by OEM of joint kit,no seperate payment will be paid to BA for this support by BA										
151	Jointing of I/D or O/D of HT (11KV ) UGC & icluding all related work and Approved Jointer	2	No.								
152	Indoor / outdoor Termination of 11 kV Armoured XLPE, AL Cable 3CX95 sqmm,120Sqmm, 185Sqmm, 300SQMM, 400SQMM including consumable	2	EA								
153	Construction of 11KV RMU Plinth with Brick, Mortar, 12 mm cement plaster and painting with enamel paint.	2	EA								
154	Installation, Testing and Commissioning of 11kV 3-way Ring Main Unit on existing structure/foundation as per TP Central Orissa Distribution Ltd. specification including grouting, loading, unloading, shifting/transportation from site/tent. Scope of work includes pipe earthing, jumpering/connection and modification to foundation at Site	2	EA								



**TP CENTRAL ODISHA DISTRIBUTION LIMITED**  
(A Tata Power & Odisha Govt. joint venture)  
2nd Floor, IDCO Tower, Janpath Bhubaneshwar, Odisha 751022

NIT No.: TPCODL/P&S/72/2020-21

155	Installation, Testing and Commissioning of 1.1kV Feeder pillar with new structure/foundation as per TP Central Orissa Distribution Ltd. specification including grouting, loading, unloading, shifting/transportation from site/tent. Scope of work includes Pipe earthing, jumpering/connection and modification to foundation at Site	2	EA								
156	Extension of one LBS in existing 11KV RMU structure specification including grouting, loading, unloading, shifting/transportation from site/tent. Scope of work includes earthing, jumpering/connection and construction / modification of foundation	2	EA								
157	Supply & Installation of HT Danger Board as per TP Central Orissa Distribution Ltd. specification	400	No.								
158	Transportation of various items from TPCODL store/site to other site or vice versa in TPCODL operational area - Truck with labours as required (price per Km). Scope of work also include loading and unloading of materials including heavy items like HT	100	MT/KM								



**TP CENTRAL ODISHA DISTRIBUTION LIMITED**  
(A Tata Power & Odisha Govt. joint venture)  
2nd Floor, IDCO Tower, Janpath Bhubaneshwar, Odisha 751022

NIT No.: TPCODL/P&S/72/2020-21

	Panel, Transformer, Cable Drum, LT Board where loading, unloading is to be done with crane and crane will be paid separately .Transport charges upto 50KM Per Metric Ton@Rs 16/KM										
159	Installation of Fire Extinguisher (5kG DCP) by means of proper hooks clamps etc. as required including providing of grouting material (cement etc.) and painting of hooks/clamps. Scope exclude supply of hook/clamp	40	No.								
160	Painting of Pole In Black & Yellow Strips/Zebra as per TP Central Orissa Distribution Ltd. specifications and indexing/numbering of Poles as per GIS format, scope also include site survey for GIS indexing and supply of ISI Marked good quality paint. (this item shall be paid for old poles only and where this not mentioned in scope)	88	No.								
161	Installation of 11KV CTPT Unit with all connection & Earthing as per TPCODL Drawing	5	No								
<b>Total All Inclusive Price</b>											



**TP CENTRAL ODISHA DISTRIBUTION LIMITED**  
(A Tata Power & Odisha Govt. joint venture)  
2nd Floor, IDCO Tower, Janpath Bhubaneshwar, Odisha 751022

NIT No.: TPCODL/P&S/72/2020-21

**Lot 8- Schedule for Items for DHENKANAL – AED & DHENKANAL -TED Division**

Sr No	Item Description	Qty	Unit	HSN /SAC Code	Unit Ex-Work Price (Rs./Unit)	GST (Rs/Unit)	Other Taxes and Duties (Rs/Unit)	Freight & Insurance Charges (Rs/Unit)	GST on Freight & Insurance Charges (Rs/Unit)	All Inclusive Unit Rate (Rs.)	Total All Inclusive Value (Rs.)
1	Supply of 150x150mm RS Joist Pole ( 11mtr )	4	No								
2	Supply of 150x150mm RS Joist Pole ( 13mtr )	2	No.								
3	9 mtr. long 116X100 RS Joist Pole(23.0Kg per Meter)	2	No.								
4	9 mtr. long 300 Kg. PSC Pole	3	No.								
5	Supply of 11 KV V cross Arm (10.2 K.g. each )	48	No.								
6	Supply of Top bracket 75x40mm MS channel ( 1.3kg each)for 11KV	48	No.								
7	Supply of Back Clamp for V cross Arm 1.70Kg each For 11KV pole	144	Pair								
8	Supply of 11 K.V.GI Pin	144	No.								
9	Supply of 11 K.V. Pin Insulator polymer	144	No.								
10	Supply of 11 K.V. H.W. Fitting (B & S)	86	No.								
11	Supply of 11 K.V. polymer Insulator (B & S) Double Disc 70KN	518	No.								
12	Supply of H.T. Stay set (Complete ) for 11KV	29	Set								
13	Supply of H.T. Stay Insulator for 11KV pole	29	No.								





**TP CENTRAL ODISHA DISTRIBUTION LIMITED**  
(A Tata Power & Odisha Govt. joint venture)  
2nd Floor, IDCO Tower, Janpath Bhubaneshwar, Odisha 751022

NIT No.: TPCODL/P&S/72/2020-21

29	Supply of 11KV AB Switch 3 Pole (400 Amp.)	2.4	Set								
30	Supply of 11KV HG Fuse 3 Pole (400 Amp.)	20	No.								
31	Supply of 11 KV L.A. 12KV-10KA	60	No.								
32	Supply of Pressure Channel 100 x 50 x 6mm MS channel each 2.8 mtr. Long( 9.2 K.g. per mtr.)X2 Nos ( Per Transformer H pole - 51.52Kg)	1030.4	Kg								
33	Supply of Transformer mounting channel 100 x 50 x 6mm MS channel each 2.8 mtr. Long( 9.2 K.g. per mtr.)X2 Nos (Per Transformer H pole -51.52Kg)	1030.4	Kg								
34	Supply of MS Angle for mounting AB Swith & HG .Channel size 75x40x6 -2.8 mtr.long, 4 nos.(6.8K.g. per mtr.)-76.16Kg per H-Pole	1523.2	Kg								
35	Supply of MS Angle for Cantilever channel for supporting AB Switch arm, Channel size 75x40x6-1 mtr. Long, 2 nos.(6.8 K.g. per mtr.) - 13.6Kg per H -Pole	272	Kg								
36	Supply of MS Angle for Cantilever channel for supporting HG Fuse . Channel size 50 x 50 x 6 mm MS Angel (1.0 mtrs. Long 2 nos.)4.5K.g. per mtr. (9Kg per TRF H Pole)	180	Kg								



**TP CENTRAL ODISHA DISTRIBUTION LIMITED**  
(A Tata Power & Odisha Govt. joint venture)  
2nd Floor, IDCO Tower, Janpath Bhubaneshwar, Odisha 751022

NIT No.: TPCODL/P&S/72/2020-21

37	Supply of MS Angle for Cantilever arrangement for AB Switch & HG Fuse. Channel size 50 x 50 x 6 -2 mtr .each 2 nos.(4.5 K.g. per mtr.) ( 18K.g. per TRF H pole)	360	Kg																
38	Supply of MS Angle for Transformer belting. Angle size 50 x 50 x 6 mm - 2.8 mtr. Long 2 nos.(4.5 K.g. per mtr.) with side angel ( Total 7 mtr.)(31.5Kg per TRF H Pole)	630	Kg																
39	Supply of MS Angle for mounting LT distribution Box 50 x 50 x 6 mm MS Angel -2.5 mtrs. each Long 2 nos.( 4.5 Kg per mtr.)(22.5Kg per TRF H Pole)	450	Kg																
40	Supply of L.T. Distribution box including Kit Kat fuse with MCCB for 25KVA S/S ( As pre CESU specification)	10	No.																
41	Supply of 3 1/2C x 35mm <sup>2</sup> PVC Cable for 25KVA TFR.	150	Mtr																
42	Supply of L.T. Distribution box with MCCB, Aluminium Busbar for 2bay with Kit Kat fuse for 100KVA S/S	4	No.																
43	Supply of 3 1/2C x 150mm <sup>2</sup> PVC Cable for 100 KVA TFR	6	Mtr																
44	Supply of L.T. Distribution box with MCCB, Aluminium Busbar for 3bay with Kit Kat fuse for 250KVA S/S	2	No.																









**TP CENTRAL ODISHA DISTRIBUTION LIMITED**  
(A Tata Power & Odisha Govt. joint venture)  
2nd Floor, IDCO Tower, Janpath Bhubaneshwar, Odisha 751022

NIT No.: TPCODL/P&S/72/2020-21

75	Supply 3CX 300Sqmm,11KV Indoor Termination Kit	2	No.								
76	Supply 3CX 400Sqmm,11KV Indoor Termination Kit	2	No.								
77	Supply 3CX 120Sqmm,11KV Indoor Termination Kit	2	No.								
78	Supply 3CX 185Sqmm,11KV Indoor Termination Kit	2	No.								
79	Supply 3CX 95Sqmm,11KV Indoor Termination Kit	2	No.								
80	Supply 3CX 400Sqmm,11KV Outdoor Termination Kit	2	No.								
81	Supply 3CX 300Sqmm,11KV Outdoor Termination Kit	2	No.								
82	Supply 3CX 185Sqmm,11KV Outdoor Termination Kit	2	No.								
83	Supply 3CX 120Sqmm,11KV Outdoor Termination Kit	2	No.								
84	3P 4 W 11 KV CT PT Combined Metering Unit Class of Accuracy 0.5 with CTR 20/5 A, with burden 15VA, PT with Burden 50VA	4	No								
85	Supply of 4C X 4Sqmm AL PVC Service cable un Arm for releasing 1PH	36720	Mtr								
86	Supply 3.5C * 35Sqmm LT PVC Cable Un armoured	12240	Mtr								
87	Supply 3.5C * 50qmm LT PVC Cable Un armoured	4896	Mtr								
88	Supply 3.5C * 95Sqmm LT PVC Cable Un armoured	4896	Mtr								





**TP CENTRAL ODISHA DISTRIBUTION LIMITED**  
(A Tata Power & Odisha Govt. joint venture)  
2nd Floor, IDCO Tower, Janpath Bhubaneshwar, Odisha 751022

NIT No.: TPCODL/P&S/72/2020-21

	using 40mm BHG metal with all labor and material except stay set , stay wire , stay insulator .										
102	Installation of Earthing of Support ( Coil Type )	88	No.								
103	Installation of Earth Pit, Charcoal, Salt etc. including construction of earthing chamber (Size: 2'x2') and RCC slab cover	100	No.								
104	Stringing of 80-100mm <sup>2</sup> AAAC	2.4	KM								
105	Painting of RS Joist Pole with fittings 2 coats of Al paint over a coat of red oxide primer including all Tools & Tackle	88	No.								
106	Installation, Testing and Commissioning of 11/0.4kV, 25kVA 3-Phase Distribution Transformer on existing structure as per TP Central Orissa Distribution Ltd. specification including loading, unloading, shifting/transportation from Division store to site /tent. Scope of work includes, jumpering/connection at HT and LT side , including minor site modification as per the TPCODL Standard Excluding Earthing	10	EA								
107	Installation, Testing and Commissioning of 11/0.4kV, 63kVA 3-Phase Distribution Transformer on existing structure	4	EA								



**TP CENTRAL ODISHA DISTRIBUTION LIMITED**  
(A Tata Power & Odisha Govt. joint venture)  
2nd Floor, IDCO Tower, Janpath Bhubaneshwar, Odisha 751022

NIT No.: TPCODL/P&S/72/2020-21

	as per TP Central Orissa Distribution Ltd. specification including loading, unloading, shifting/transportation from Division store to site /tent. Scope of work includes, jumpering/connection at HT and LT side , including minor site modification as per the TPCODL Standard Excluding Earthing										
108	Installation, Testing and Commissioning of 11/0.4kV, 100kVA 3-Phase Distribution Transformer on existing structure as per TP Central Orissa Distribution Ltd. specification including loading, unloading, shifting/transportation from Division store to site /tent. Scope of work includes, jumpering/connection at HT and LT side , including minor site modification as per the TPCODL Standard Excluding Earthing	4	EA								
109	Installation, Testing and Commissioning of 11/0.4kV, 250kVA 3-Phase Distribution Transformer on existing structure as per TP Central Orissa Distribution Ltd. specification including loading, unloading, shifting/transportation from site /tent. Scope of work includes	2	EA								



**TP CENTRAL ODISHA DISTRIBUTION LIMITED**  
(A Tata Power & Odisha Govt. joint venture)  
2nd Floor, IDCO Tower, Janpath Bhubaneshwar, Odisha 751022

NIT No.: TPCODL/P&S/72/2020-21

	earthing, jumpering/connection at HT and LT side as per the TPCODL Standard										
110	Installation of Outdoor Type Distribution Box with 40A MCCB with O/G for 11/0.4kV,25kVA Three Phase Transformer as per TP Central Orissa Distribution Ltd. specification	10	No								
111	Installation of Outdoor Type Distribution Box with 100A MCCB with O/G for 11/0.4kV,63kVA Three Phase Transformer as per TP Central Orissa Distribution Ltd. specification	4	No								
112	Installation of Outdoor Type Distribution Box (BOX DIST.WITH 160A 35KA TP MCCB 6 O/G) for 100KVA TRF	4	No								
113	Installation testing and commissioning of LT ACB 400 Amps with enclosure for 11/0.4KV 250KVA Threephase Transformer	2	No								
114	Installation of Outdoor Type Distribution Box(BOX DIST.WITH 500A 50KA TP MCCB 5 O/G) with MCCB for 11/0.4kV,250kVA Three Phase Transformer on existing structure as per TP Central Orissa Distribution Ltd. Specification	2	No								
115	Plinth for TFR 6ft hight (below GL2ft)x5ftx5ft	6	No								



**TP CENTRAL ODISHA DISTRIBUTION LIMITED**  
(A Tata Power & Odisha Govt. joint venture)  
2nd Floor, IDCO Tower, Janpath Bhubaneshwar, Odisha 751022

NIT No.: TPCODL/P&S/72/2020-21

116	Plinth for L.T. Distribution box 6ft high (below GL2ft)x5ftx5ft	2	No								
117	Installation of GI barbed wire anticlimbing device 2 Kg. Per support	176	Kg								
118	Installation of different size MS Channel for 50 S/S	5440	Kg								
119	Installation of different size MS Channel for DP in 6KM line	945.6	Kg								
120	Supply of GI Nut , Bolt & Washer of different sizes For line with DP for 6KM Line (70KG PER KM LINE)	168	Kg								
121	Supply of GI Nut , Bolt & Washer of different sizes For 50S/S ( 36KG Per s/s)	720	Kg								
122	Painting of RS Joist	88	No								
123	Dismantling of RS Joist pole(150x150mm/Rail pole) & return back to section store	8	No								
124	Dismantling of RS Joist pole(116x100mm)	8	No								
125	Dismantling of PSC pole (9mtr)	8	No								
126	Dismantling of 11KV 'V' Cross arm	8	No								
127	Dismantling of 11KV GI pin with insulator	24	No								
128	Dismantling of 11KV Disc insulator with HW Fitting	24	No								
129	Dismantling of MS Channel from 11KV Pole / DP	40	Kg								
130	Dismantling of 55mm <sup>2</sup> AAA Conductor	0.2	KM								



**TP CENTRAL ODISHA DISTRIBUTION LIMITED**  
(A Tata Power & Odisha Govt. joint venture)  
2nd Floor, IDCO Tower, Janpath Bhubaneshwar, Odisha 751022

NIT No.: TPCODL/P&S/72/2020-21

131	Dismantling of 80mm <sup>2</sup> AAA Conductor	0.2	KM								
132	Dismantling of 100mm <sup>2</sup> AAA Conductor	0.2	KM								
133	Sundries for survey tree cutting, small size nut bolt, Aluminium Binding wire / tape & Danger Board 4 Nos. etc. Line length of 1KM	2.4	LS								
134	Sundries for survey tree cutting, small size nut bolt, Aluminium. Binding wire / tape & Danger Board 4 Nos. etc. Substation upto 250KVA	20	LS								
135	Installation of Dead end clamp on LT Pole	24	No.								
136	Installation of Suspension clamp with I-Hook on LT Pole	72	No.								
137	Installation of Strain fittings on LT pole	19	No.								
138	Installation of Guy grip Dead end for LT Pole	19	No.								
139	Installation of Earthing Coil TO POLE	17	No.								
140	Laying / stringing of AB Cable( 3 x50 + 1x35mm <sup>2</sup> )	2400	Mtr.								
141	Laying / Stringing of AB Cable( 3 x35 + 1x25mm <sup>2</sup> )	2400	Mtr.								
142	Laying / Stringing of AB Cable( 3 x50 + 1x35mm <sup>2</sup> +1X16mm <sup>2</sup> )	2400	Mtr.								
143	Laying / Stringing of AB Cable( 3 x95 + 1x70mm <sup>2</sup> +1X16mm <sup>2</sup> )	2400	Mtr.								





**TP CENTRAL ODISHA DISTRIBUTION LIMITED**  
(A Tata Power & Odisha Govt. joint venture)  
2nd Floor, IDCO Tower, Janpath Bhubaneshwar, Odisha 751022

NIT No.: TPCODL/P&S/72/2020-21

144	Laying of Service cable 4sqmm x 2C	2	Mtr.								
145	Laying of 1.1KV 3.5C, 35Sqmm AL XLPE Cable	12240	Mtr.								
146	Laying of 1.1KV 3.5C, 150SqmmAL XLPE Cable	4896	Mtr.								
147	Laying of 1.1KV 4C, 240Sqmm AL XLPE Cable	4896	Mtr.								
148	Laying of 1.1KV 3.5C, 300Sqmm AL XLPE Cable	50	Mtr.								
149	Laying & EXCAVATION (1M Depth * 0.875M Width) of 11kV Armoured XLPE AL Cable 3CX95 sqmm/ 3CX120 sqmm in S/Sth. Trench/Tray as per TP Central Orissa Distribution Ltd. specification including testing of cable. Scope of work exclude fixing of Tray.BA will provide support during joint making by OEM of joint kit,no separate payment will be paid to BA for this support by BA	50	Mtr.								
150	Laying & Excavation (1M Depth * 0.875M) of 11kV Armoured XLPE AL Cable 3CX400/ 3X300 sqmm in S/Sth. Trench/Tray as per TP Central Orissa Distribution Ltd. specification including testing of cable. Scope of work exclude fixing of Tray.BA will provide support during joint making by	50	Mtr.								



**TP CENTRAL ODISHA DISTRIBUTION LIMITED**  
(A Tata Power & Odisha Govt. joint venture)  
2nd Floor, IDCO Tower, Janpath Bhubaneshwar, Odisha 751022

NIT No.: TPCODL/P&S/72/2020-21

	OEM of joint kit,no seperate payment will be paid to BA for this support by BA										
151	Jointing of I/D or O/D of HT (11KV ) UGC & icluding all related work and Approved Jointer	2	No.								
152	Indoor / outdoor Termination of 11 kV Armoured XLPE, AL Cable 3CX95 sqmm,120Sqmm, 185Sqmm, 300SQMM, 400SQMM including consumable	2	EA								
153	Construction of 11KV RMU Plinth with Brick, Mortar, 12 mm cement plaster and painting with enamel paint.	2	EA								
154	Installation, Testing and Commissioning of 11kV 3-way Ring Main Unit on existing structure/foundation as per TP Central Orissa Distribution Ltd. specification including grouting, loading, unloading, shifting/transportation from site/tent. Scope of work includes pipe earthing, jumpering/connection and modification to foundation at Site	2	EA								
155	Installation, Testing and Commissioning of 1.1kV Feeder pillar with new structure/foundation as per TP Central Orissa Distribution Ltd. specification	2	EA								



**TP CENTRAL ODISHA DISTRIBUTION LIMITED**  
(A Tata Power & Odisha Govt. joint venture)  
2nd Floor, IDCO Tower, Janpath Bhubaneshwar, Odisha 751022

NIT No.: TPCODL/P&S/72/2020-21

	including grouting, loading, unloading, shifting/transportation from site/tent. Scope of work includes Pipe earthing, jumpering/connection and modification to foundation at Site										
156	Extension of one LBS in existing 11KV RMU structure specification including grouting, loading, unloading, shifting/transportation from site/tent. Scope of work includes earthing, jumpering/connection and construction / modification of foundation	2	EA								
157	Supply & Installation of HT Danger Board as per TP Central Orissa Distribution Ltd. specification	400	No.								
158	Transportation of various items from TPCODL store/site to other site or vice versa in TPCODL operational area - Truck with labours as required (price per Km). Scope of work also include loading and unloading of materials including heavy items like HT Panel, Transformer, Cable Drum, LT Board where loading, unloading is to be done with crane and crane will be paid separately .Transport	100	MT/KM								



**TP CENTRAL ODISHA DISTRIBUTION LIMITED**  
(A Tata Power & Odisha Govt. joint venture)  
2nd Floor, IDCO Tower, Janpath Bhubaneshwar, Odisha 751022

NIT No.: TPCODL/P&S/72/2020-21

	charges upto 50KM Per Metric Ton@Rs 16/KM										
159	Installation of Fire Extinguisher (5kG DCP) by means of proper hooks clamps etc. as required including providing of grouting material (cement etc.) and painting of hooks/clamps. Scope exclude supply of hook/clamp	40	No.								
160	Painting of Pole In Black & Yellow Strips/Zebra as per TP Central Orissa Distribution Ltd. specifications and indexing/numbering of Poles as per GIS format, scope also include site survey for GIS indexing and supply of ISI Marked good quality paint. (this item shall be paid for old poles only and where this not mentioned in scope)	88	No.								
161	Installation of 11KV CTPT Unit with all connection & Earthing as per TPCODL Drawing	5	No								
<b>Total All Inclusive Price</b>											



**TP CENTRAL ODISHA DISTRIBUTION LIMITED**  
(A Tata Power & Odisha Govt. joint venture)  
2nd Floor, IDCO Tower, Janpath Bhubaneshwar, Odisha 751022

NIT No.: TPCODL/P&S/72/2020-21

**Lot 9- Schedule for Items for PARADEEP – KED-1 & KED-2 Division**

Sr No	Item Description	Qty	Unit	HSN /SAC Code	Unit Ex-Work Price (Rs./Unit)	GST (Rs/Unit)	Other Taxes and Duties (Rs/Unit)	Freight & Insurance Charges (Rs/Unit)	GST on Freight & Insurance Charges (Rs/Unit)	All Inclusive Unit Rate (Rs.)	Total All Inclusive Value (Rs.)
1	Supply of 150x150mm RS Joist Pole ( 11mtr )	4	No								
2	Supply of 150x150mm RS Joist Pole ( 13mtr )	2	No.								
3	9 mtr. long 116X100 RS Joist Pole(23.0Kg per Meter)	2	No.								
4	9 mtr. long 300 Kg. PSC Pole	3	No.								
5	Supply of 11 KV V cross Arm (10.2 K.g. each )	48	No.								
6	Supply of Top bracket 75x40mm MS channel ( 1.3kg each)for 11KV	48	No.								
7	Supply of Back Clamp for V cross Arm 1.70Kg each For 11KV pole	144	Pair								
8	Supply of 11 K.V.GI Pin	144	No.								
9	Supply of 11 K.V. Pin Insulator polymer	144	No.								
10	Supply of 11 K.V. H.W. Fitting (B & S)	86	No.								
11	Supply of 11 K.V. polymer Insulator (B & S) Double Disc 70KN	518	No.								
12	Supply of H.T. Stay set (Complete ) for 11KV	29	Set								
13	Supply of H.T. Stay Insulator for 11KV pole	29	No.								





**TP CENTRAL ODISHA DISTRIBUTION LIMITED**  
(A Tata Power & Odisha Govt. joint venture)  
2nd Floor, IDCO Tower, Janpath Bhubaneshwar, Odisha 751022

NIT No.: TPCODL/P&S/72/2020-21

29	Supply of 11KV AB Switch 3 Pole (400 Amp.)	2.4	Set								
30	Supply of 11KV HG Fuse 3 Pole (400 Amp.)	20	No.								
31	Supply of 11 KV L.A. 12KV-10KA	60	No.								
32	Supply of Pressure Channel 100 x 50 x 6mm MS channel each 2.8 mtr. Long( 9.2 K.g. per mtr.)X2 Nos ( Per Transformer H pole - 51.52Kg)	1030.4	Kg								
33	Supply of Transformer mounting channel 100 x 50 x 6mm MS channel each 2.8 mtr. Long( 9.2 K.g. per mtr.)X2 Nos (Per Transformer H pole -51.52Kg)	1030.4	Kg								
34	Supply of MS Angle for mounting AB Swith & HG .Channel size 75x40x6 -2.8 mtr.long, 4 nos.(6.8K.g. per mtr.)-76.16Kg per H-Pole	1523.2	Kg								
35	Supply of MS Angle for Cantilever channel for supporting AB Switch arm, Channel size 75x40x6-1 mtr. Long, 2 nos.(6.8 K.g. per mtr.) - 13.6Kg per H -Pole	272	Kg								
36	Supply of MS Angle for Cantilever channel for supporting HG Fuse . Channel size 50 x 50 x 6 mm MS Angel (1.0 mtrs. Long 2 nos.)4.5K.g. per mtr. (9Kg per TRF H Pole)	180	Kg								



**TP CENTRAL ODISHA DISTRIBUTION LIMITED**  
(A Tata Power & Odisha Govt. joint venture)  
2nd Floor, IDCO Tower, Janpath Bhubaneshwar, Odisha 751022

NIT No.: TPCODL/P&S/72/2020-21

37	Supply of MS Angle for Cantilever arrangement for AB Switch & HG Fuse. Channel size 50 x 50 x 6 -2 mtr .each 2 nos.(4.5 K.g. per mtr.) ( 18K.g. per TRF H pole)	360	Kg																	
38	Supply of MS Angle for Transformer belting. Angle size 50 x 50 x 6 mm - 2.8 mtr. Long 2 nos.(4.5 K.g. per mtr.) with side angel ( Total 7 mtr.)(31.5Kg per TRF H Pole)	630	Kg																	
39	Supply of MS Angle for mounting LT distribution Box 50 x 50 x 6 mm MS Angel -2.5 mtrs. each Long 2 nos.( 4.5 Kg per mtr.)(22.5Kg per TRF H Pole)	450	Kg																	
40	Supply of L.T. Distribution box including Kit Kat fuse with MCCB for 25KVA S/S ( As pre CESU specification)	10	No.																	
41	Supply of 3 1/2C x 35mm <sup>2</sup> PVC Cable for 25KVA TFR.	150	Mtr																	
42	Supply of L.T. Distribution box with MCCB, Aluminium Busbar for 2bay with Kit Kat fuse for 100KVA S/S	4	No.																	
43	Supply of 3 1/2C x 150mm <sup>2</sup> PVC Cable for 100 KVA TFR	6	Mtr																	
44	Supply of L.T. Distribution box with MCCB, Aluminium Busbar for 3bay with Kit Kat fuse for 250KVA S/S	2	No.																	





**TP CENTRAL ODISHA DISTRIBUTION LIMITED**  
(A Tata Power & Odisha Govt. joint venture)  
2nd Floor, IDCO Tower, Janpath Bhubaneshwar, Odisha 751022

NIT No.: TPCODL/P&S/72/2020-21

45	Supply of 3 1/2C x 300mm <sup>2</sup> PVC Cable for 500 KVA TFR I/C	6	Mtr								
46	Supply of Concrete slab for base place size 2ftx2ftx2" thickness for each PSC pole	79	No.								
47	Supply of LT Stay set Complete	19	Set								
48	Supply of 7/12 SWG Stay Wire	192	Kg								
49	Supply of LT Stay clamp (1.4 K.g./ Pair )	19	pair								
50	Supply of LT Stay Insulator	19	No.								
51	Supply of Dead end clamp	24	No.								
52	Supply of Suspension clamp with I-Hook	72	No.								
53	Supply of Strain fittings	19	No.								
54	Supply of Guy grip Dead end for Pole	19	No.								
55	Supply of Nuts and Bolts	57.6	Kg								
56	Supply Earthing Coil each 5th pole to earth	17	No.								
57	Supply of AB Cable( 3 x50 + 1x35mm <sup>2</sup> )	0.1	Km								
58	Supply of AB Cable( 3 x35 + 1x25mm <sup>2</sup> )	1	Km								
59	Supply of AB Cable( 3 x50 + 1x35mm <sup>2</sup> +1X16mm <sup>2</sup> )	0.1	Km								
60	Supply of AB Cable( 3 x95 + 1x70mm <sup>2</sup> +1X16mm <sup>2</sup> )	0.1	Km								
61	Supply of 1.1KV, 4C, 240Sqmm for XLPE Cable, AL,ARM	50	Mtr.								
62	Supply of 1.1KV, 4C, 300Sqmm for XLPE Cable,AL,ARM	50	No.								





**TP CENTRAL ODISHA DISTRIBUTION LIMITED**  
(A Tata Power & Odisha Govt. joint venture)  
2nd Floor, IDCO Tower, Janpath Bhubaneshwar, Odisha 751022

NIT No.: TPCODL/P&S/72/2020-21

75	Supply 3CX 300Sqmm,11KV Indoor Termination Kit	2	No.								
76	Supply 3CX 400Sqmm,11KV Indoor Termination Kit	2	No.								
77	Supply 3CX 120Sqmm,11KV Indoor Termination Kit	2	No.								
78	Supply 3CX 185Sqmm,11KV Indoor Termination Kit	2	No.								
79	Supply 3CX 95Sqmm,11KV Indoor Termination Kit	2	No.								
80	Supply 3CX 400Sqmm,11KV Outdoor Termination Kit	2	No.								
81	Supply 3CX 300Sqmm,11KV Outdoor Termination Kit	2	No.								
82	Supply 3CX 185Sqmm,11KV Outdoor Termination Kit	2	No.								
83	Supply 3CX 120Sqmm,11KV Outdoor Termination Kit	2	No.								
84	3P 4 W 11 KV CT PT Combined Metering Unit Class of Accuracy 0.5 with CTR 20/5 A, with burden 15VA, PT with Burden 50VA	4	No								
85	Supply of 4C X 4Sqmm AL PVC Service cable un Arm for releasing 1PH	36720	Mtr								
86	Supply 3.5C * 35Sqmm LT PVC Cable Un armoured	12240	Mtr								
87	Supply 3.5C * 50qmm LT PVC Cable Un armoured	4896	Mtr								
88	Supply 3.5C * 95Sqmm LT PVC Cable Un armoured	4896	Mtr								





**TP CENTRAL ODISHA DISTRIBUTION LIMITED**  
(A Tata Power & Odisha Govt. joint venture)  
2nd Floor, IDCO Tower, Janpath Bhubaneshwar, Odisha 751022

NIT No.: TPCODL/P&S/72/2020-21

	using 40mm BHG metal with all labor and material except stay set , stay wire , stay insulator .										
102	Installation of Earthing of Support ( Coil Type )	88	No.								
103	Installation of Earth Pit, Charcoal, Salt etc. including construction of earthing chamber (Size: 2'x2') and RCC slab cover	100	No.								
104	Stringing of 80-100mm <sup>2</sup> AAAC	2.4	KM								
105	Painting of RS Joist Pole with fittings 2 coats of Al paint over a coat of red oxide primer including all Tools & Tackle	88	No.								
106	Installation, Testing and Commissioning of 11/0.4kV, 25kVA 3-Phase Distribution Transformer on existing structure as per TP Central Orissa Distribution Ltd. specification including loading, unloading, shifting/transportation from Division store to site /tent. Scope of work includes, jumpering/connection at HT and LT side , including minor site modification as per the TPCODL Standard Excluding Earthing	10	EA								
107	Installation, Testing and Commissioning of 11/0.4kV, 63kVA 3-Phase Distribution Transformer on existing structure	4	EA								



**TP CENTRAL ODISHA DISTRIBUTION LIMITED**  
(A Tata Power & Odisha Govt. joint venture)  
2nd Floor, IDCO Tower, Janpath Bhubaneshwar, Odisha 751022

NIT No.: TPCODL/P&S/72/2020-21

	as per TP Central Orissa Distribution Ltd. specification including loading, unloading, shifting/transportation from Division store to site /tent. Scope of work includes, jumpering/connection at HT and LT side , including minor site modification as per the TPCODL Standard Excluding Earthing										
108	Installation, Testing and Commissioning of 11/0.4kV, 100kVA 3-Phase Distribution Transformer on existing structure as per TP Central Orissa Distribution Ltd. specification including loading, unloading, shifting/transportation from Division store to site /tent. Scope of work includes, jumpering/connection at HT and LT side , including minor site modification as per the TPCODL Standard Excluding Earthing	4	EA								
109	Installation, Testing and Commissioning of 11/0.4kV, 250kVA 3-Phase Distribution Transformer on existing structure as per TP Central Orissa Distribution Ltd. specification including loading, unloading, shifting/transportation from site /tent. Scope of work includes	2	EA								



**TP CENTRAL ODISHA DISTRIBUTION LIMITED**  
(A Tata Power & Odisha Govt. joint venture)  
2nd Floor, IDCO Tower, Janpath Bhubaneshwar, Odisha 751022

NIT No.: TPCODL/P&S/72/2020-21

	earthing, jumpering/connection at HT and LT side as per the TPCODL Standard										
110	Installation of Outdoor Type Distribution Box with 40A MCCB with O/G for 11/0.4kV,25kVA Three Phase Transformer as per TP Central Orissa Distribution Ltd. specification	10	No								
111	Installation of Outdoor Type Distribution Box with 100A MCCB with O/G for 11/0.4kV,63kVA Three Phase Transformer as per TP Central Orissa Distribution Ltd. specification	4	No								
112	Installation of Outdoor Type Distribution Box (BOX DIST.WITH 160A 35KA TP MCCB 6 O/G) for 100KVA TRF	4	No								
113	Installation testing and commissioning of LT ACB 400 Amps with enclosure for 11/0.4KV 250KVA Threephase Transformer	2	No								
114	Installation of Outdoor Type Distribution Box(BOX DIST.WITH 500A 50KA TP MCCB 5 O/G) with MCCB for 11/0.4kV,250kVA Three Phase Transformer on existing structure as per TP Central Orissa Distribution Ltd. Specification	2	No								
115	Plinth for TFR 6ft hight (below GL2ft)x5ftx5ft	6	No								







**TP CENTRAL ODISHA DISTRIBUTION LIMITED**  
(A Tata Power & Odisha Govt. joint venture)  
2nd Floor, IDCO Tower, Janpath Bhubaneshwar, Odisha 751022

NIT No.: TPCODL/P&S/72/2020-21

131	Dismantling of 80mm <sup>2</sup> AAA Conductor	0.2	KM								
132	Dismantling of 100mm <sup>2</sup> AAA Conductor	0.2	KM								
133	Sundries for survey tree cutting, small size nut bolt, Aluminium Binding wire / tape & Danger Board 4 Nos. etc. Line length of 1KM	2.4	LS								
134	Sundries for survey tree cutting, small size nut bolt, Aluminium. Binding wire / tape & Danger Board 4 Nos. etc. Substation upto 250KVA	20	LS								
135	Installation of Dead end clamp on LT Pole	24	No.								
136	Installation of Suspension clamp with I-Hook on LT Pole	72	No.								
137	Installation of Strain fittings on LT pole	19	No.								
138	Installation of Guy grip Dead end for LT Pole	19	No.								
139	Installation of Earthing Coil TO POLE	17	No.								
140	Laying / stringing of AB Cable( 3 x50 + 1x35mm <sup>2</sup> )	2400	Mtr.								
141	Laying / Stringing of AB Cable( 3 x35 + 1x25mm <sup>2</sup> )	2400	Mtr.								
142	Laying / Stringing of AB Cable( 3 x50 + 1x35mm <sup>2</sup> +1X16mm <sup>2</sup> )	2400	Mtr.								
143	Laying / Stringing of AB Cable( 3 x95 + 1x70mm <sup>2</sup> +1X16mm <sup>2</sup> )	2400	Mtr.								



**TP CENTRAL ODISHA DISTRIBUTION LIMITED**  
(A Tata Power & Odisha Govt. joint venture)  
2nd Floor, IDCO Tower, Janpath Bhubaneshwar, Odisha 751022

NIT No.: TPCODL/P&S/72/2020-21

144	Laying of Service cable 4sqmm x 2C	2	Mtr.								
145	Laying of 1.1KV 3.5C, 35Sqmm AL XLPE Cable	12240	Mtr.								
146	Laying of 1.1KV 3.5C, 150SqmmAL XLPE Cable	4896	Mtr.								
147	Laying of 1.1KV 4C, 240Sqmm AL XLPE Cable	4896	Mtr.								
148	Laying of 1.1KV 3.5C, 300Sqmm AL XLPE Cable	50	Mtr.								
149	Laying & EXCAVATION (1M Depth * 0.875M Width) of 11kV Armoured XLPE AL Cable 3CX95 sqmm/ 3CX120 sqmm in S/Sth. Trench/Tray as per TP Central Orissa Distribution Ltd. specification including testing of cable. Scope of work exclude fixing of Tray.BA will provide support during joint making by OEM of joint kit,no separate payment will be paid to BA for this support by BA	50	Mtr.								
150	Laying & Excavation (1M Depth * 0.875M) of 11kV Armoured XLPE AL Cable 3CX400/ 3X300 sqmm in S/Sth. Trench/Tray as per TP Central Orissa Distribution Ltd. specification including testing of cable. Scope of work exclude fixing of Tray.BA will provide support during joint making by	50	Mtr.								



**TP CENTRAL ODISHA DISTRIBUTION LIMITED**  
(A Tata Power & Odisha Govt. joint venture)  
2nd Floor, IDCO Tower, Janpath Bhubaneshwar, Odisha 751022

NIT No.: TPCODL/P&S/72/2020-21

	OEM of joint kit,no seperate payment will be paid to BA for this support by BA										
151	Jointing of I/D or O/D of HT (11KV ) UGC & icluding all related work and Approved Jointer	2	No.								
152	Indoor / outdoor Termination of 11 kV Armoured XLPE, AL Cable 3CX95 sqmm,120Sqmm, 185Sqmm, 300SQMM, 400SQMM including consumable	2	EA								
153	Construction of 11KV RMU Plinth with Brick, Mortar, 12 mm cement plaster and painting with enamel paint.	2	EA								
154	Installation, Testing and Commissioning of 11kV 3-way Ring Main Unit on existing structure/foundation as per TP Central Orissa Distribution Ltd. specification including grouting, loading, unloading, shifting/transportation from site/tent. Scope of work includes pipe earthing, jumpering/connection and modification to foundation at Site	2	EA								
155	Installation, Testing and Commissioning of 1.1kV Feeder pillar with new structure/foundation as per TP Central Orissa Distribution Ltd. specification	2	EA								



**TP CENTRAL ODISHA DISTRIBUTION LIMITED**  
(A Tata Power & Odisha Govt. joint venture)  
2nd Floor, IDCO Tower, Janpath Bhubaneshwar, Odisha 751022

NIT No.: TPCODL/P&S/72/2020-21

	including grouting, loading, unloading, shifting/transportation from site/tent. Scope of work includes Pipe earthing, jumpering/connection and modification to foundation at Site										
156	Extension of one LBS in existing 11KV RMU structure specification including grouting, loading, unloading, shifting/transportation from site/tent. Scope of work includes earthing, jumpering/connection and construction / modification of foundation	2	EA								
157	Supply & Installation of HT Danger Board as per TP Central Orissa Distribution Ltd. specification	400	No.								
158	Transportation of various items from TPCODL store/site to other site or vice versa in TPCODL operational area - Truck with labours as required (price per Km). Scope of work also include loading and unloading of materials including heavy items like HT Panel, Transformer, Cable Drum, LT Board where loading, unloading is to be done with crane and crane will be paid separately .Transport	100	MT/KM								



**TP CENTRAL ODISHA DISTRIBUTION LIMITED**  
(A Tata Power & Odisha Govt. joint venture)  
2nd Floor, IDCO Tower, Janpath Bhubaneshwar, Odisha 751022

NIT No.: TPCODL/P&S/72/2020-21

	charges upto 50KM Per Metric Ton@Rs 16/KM										
159	Installation of Fire Extinguisher (5kG DCP) by means of proper hooks clamps etc. as required including providing of grouting material (cement etc.) and painting of hooks/clamps. Scope exclude supply of hook/clamp	40	No.								
160	Painting of Pole In Black & Yellow Strips/Zebra as per TP Central Orissa Distribution Ltd. specifications and indexing/numbering of Poles as per GIS format, scope also include site survey for GIS indexing and supply of ISI Marked good quality paint. (this item shall be paid for old poles only and where this not mentioned in scope)	88	No.								
161	Installation of 11KV CTPT Unit with all connection & Earthing as per TPCODL Drawing	5	No								
<b>Total All Inclusive Price</b>											



**TP CENTRAL ODISHA DISTRIBUTION LIMITED**  
(A Tata Power & Odisha Govt. joint venture)  
2nd Floor, IDCO Tower, Janpath Bhubaneshwar, Odisha 751022

NIT No.: TPCODL/P&S/72/2020-21

**Lot 10- Schedule for Items for PARADEEP – PED & JED Division**

Sr No	Item Description	Qty	Unit	HSN /SAC Code	Unit Ex-Work Price (Rs./Unit)	GST (Rs/Unit)	Other Taxes and Duties (Rs/Unit)	Freight & Insurance Charges (Rs/Unit)	GST on Freight & Insurance Charges (Rs/Unit)	All Inclusive Unit Rate (Rs.)	Total All Inclusive Value (Rs.)
1	Supply of 150x150mm RS Joist Pole ( 11mtr )	4	No								
2	Supply of 150x150mm RS Joist Pole ( 13mtr )	2	No.								
3	9 mtr. long 116X100 RS Joist Pole(23.0Kg per Meter)	2	No.								
4	9 mtr. long 300 Kg. PSC Pole	3	No.								
5	Supply of 11 KV V cross Arm (10.2 K.g. each )	48	No.								
6	Supply of Top bracket 75x40mm MS channel ( 1.3kg each)for 11KV	48	No.								
7	Supply of Back Clamp for V cross Arm 1.70Kg each For 11KV pole	144	Pair								
8	Supply of 11 K.V.GI Pin	144	No.								
9	Supply of 11 K.V. Pin Insulator polymer	144	No.								
10	Supply of 11 K.V. H.W. Fitting (B & S)	86	No.								
11	Supply of 11 K.V. polymer Insulator (B & S) Double Disc 70KN	518	No.								
12	Supply of H.T. Stay set (Complete ) for 11KV	29	Set								
13	Supply of H.T. Stay Insulator for 11KV pole	29	No.								



**TP CENTRAL ODISHA DISTRIBUTION LIMITED**  
(A Tata Power & Odisha Govt. joint venture)  
2nd Floor, IDCO Tower, Janpath Bhubaneshwar, Odisha 751022

NIT No.: TPCODL/P&S/72/2020-21

14	Supply of H.T. Stay clamp (1.95 K.g./ Pair ) for 11KV Pole	29	Pair																
15	Supply of 7/10 SWG Stay Wire 10kg /stay for 11KV Pole	288	K.g.																
16	Supply of Earthing of Support for 11KV Pole ( Coil Type )	48	No.																
17	Supply of Red Oxide paint (1.2Kg per 11KV Pole)	57.6	Ltr																
18	Supply of Aluminium Paint ( 1.2Kg per 11KV Pole)	57.6	Ltr																
19	Supply of Black Paint ( 0.3Kg per 11KV Pole)	14.4	Ltr																
20	Supply of GI barbed wire anticlimbing device 2 Kg. Per support for 11KV Pole	96	Kg																
21	Supply of 100 x 50 x 6 mm MS channel for 4nos Cut point ( 52Kg per Cutpoint)	748.8	Kg																
22	Supply of 75 x 40 x 6 mm MS channel for 11KV DP	196.8	Kg																
23	Supply of 50X50X6mm Cross Bressing Angel for of 11KV DP	196.8	Kg																
24	Supply of GI Pipe for Earthing 40 Dia Medium gage 3 mtrs. Long	100	No.																
25	40x6mm GI Flat for neutral	400	Kg																
26	Supply of 3 1/2 x 35mm <sup>2</sup> PVC Cable for 25KVA TFR.	150	Mtr																
27	Supply of Ms Nut , Bolt & Washer of different sizes	42.4	Kg																
28	Supply of 11KV AB Switch 3 Pole (200 Amp.)	20	Set																



**TP CENTRAL ODISHA DISTRIBUTION LIMITED**  
(A Tata Power & Odisha Govt. joint venture)  
2nd Floor, IDCO Tower, Janpath Bhubaneshwar, Odisha 751022

NIT No.: TPCODL/P&S/72/2020-21

29	Supply of 11KV AB Switch 3 Pole (400 Amp.)	2.4	Set								
30	Supply of 11KV HG Fuse 3 Pole (400 Amp.)	20	No.								
31	Supply of 11 KV L.A. 12KV-10KA	60	No.								
32	Supply of Pressure Channel 100 x 50 x 6mm MS channel each 2.8 mtr. Long( 9.2 K.g. per mtr.)X2 Nos ( Per Transformer H pole - 51.52Kg)	1030.4	Kg								
33	Supply of Transformer mounting channel 100 x 50 x 6mm MS channel each 2.8 mtr. Long( 9.2 K.g. per mtr.)X2 Nos (Per Transformer H pole -51.52Kg)	1030.4	Kg								
34	Supply of MS Angle for mounting AB Swith & HG .Channel size 75x40x6 -2.8 mtr.long, 4 nos.(6.8K.g. per mtr.)-76.16Kg per H-Pole	1523.2	Kg								
35	Supply of MS Angle for Cantilever channel for supporting AB Switch arm, Channel size 75x40x6-1 mtr. Long, 2 nos.(6.8 K.g. per mtr.) - 13.6Kg per H -Pole	272	Kg								
36	Supply of MS Angle for Cantilever channel for supporting HG Fuse . Channel size 50 x 50 x 6 mm MS Angel (1.0 mtrs. Long 2 nos.)4.5K.g. per mtr. (9Kg per TRF H Pole)	180	Kg								





**TP CENTRAL ODISHA DISTRIBUTION LIMITED**  
(A Tata Power & Odisha Govt. joint venture)  
2nd Floor, IDCO Tower, Janpath Bhubaneshwar, Odisha 751022

NIT No.: TPCODL/P&S/72/2020-21

37	Supply of MS Angle for Cantilever arrangement for AB Switch & HG Fuse. Channel size 50 x 50 x 6 -2 mtr .each 2 nos.(4.5 K.g. per mtr.) ( 18K.g. per TRF H pole)	360	Kg								
38	Supply of MS Angle for Transformer belting. Angle size 50 x 50 x 6 mm - 2.8 mtr. Long 2 nos.(4.5 K.g. per mtr.) with side angel ( Total 7 mtr.)(31.5Kg per TRF H Pole)	630	Kg								
39	Supply of MS Angle for mounting LT distribution Box 50 x 50 x 6 mm MS Angel -2.5 mtrs. each Long 2 nos.( 4.5 Kg per mtr.)(22.5Kg per TRF H Pole)	450	Kg								
40	Supply of L.T. Distribution box including Kit Kat fuse with MCCB for 25KVA S/S ( As pre CESU specification)	10	No.								
41	Supply of 3 1/2C x 35mm <sup>2</sup> PVC Cable for 25KVA TFR.	150	Mtr								
42	Supply of L.T. Distribution box with MCCB, Aluminium Busbar for 2bay with Kit Kat fuse for 100KVA S/S	4	No.								
43	Supply of 3 1/2C x 150mm <sup>2</sup> PVC Cable for 100 KVA TFR	6	Mtr								
44	Supply of L.T. Distribution box with MCCB, Aluminium Busbar for 3bay with Kit Kat fuse for 250KVA S/S	2	No.								



**TP CENTRAL ODISHA DISTRIBUTION LIMITED**  
(A Tata Power & Odisha Govt. joint venture)  
2nd Floor, IDCO Tower, Janpath Bhubaneshwar, Odisha 751022

NIT No.: TPCODL/P&S/72/2020-21

45	Supply of 3 1/2C x 300mm <sup>2</sup> PVC Cable for 500 KVA TFR I/C	6	Mtr								
46	Supply of Concrete slab for base place size 2ftx2ftx2" thickness for each PSC pole	79	No.								
47	Supply of LT Stay set Complete	19	Set								
48	Supply of 7/12 SWG Stay Wire	192	Kg								
49	Supply of LT Stay clamp (1.4 K.g./ Pair )	19	pair								
50	Supply of LT Stay Insulator	19	No.								
51	Supply of Dead end clamp	24	No.								
52	Supply of Suspension clamp with I-Hook	72	No.								
53	Supply of Strain fittings	19	No.								
54	Supply of Guy grip Dead end for Pole	19	No.								
55	Supply of Nuts and Bolts	57.6	Kg								
56	Supply Earthing Coil each 5th pole to earth	17	No.								
57	Supply of AB Cable( 3 x50 + 1x35mm <sup>2</sup> )	0.1	Km								
58	Supply of AB Cable( 3 x35 + 1x25mm <sup>2</sup> )	1	Km								
59	Supply of AB Cable( 3 x50 + 1x35mm <sup>2</sup> +1X16mm <sup>2</sup> )	0.1	Km								
60	Supply of AB Cable( 3 x95 + 1x70mm <sup>2</sup> +1X16mm <sup>2</sup> )	0.1	Km								
61	Supply of 1.1KV, 4C, 240Sqmm for XLPE Cable, AL,ARM	50	Mtr.								
62	Supply of 1.1KV, 4C, 300Sqmm for XLPE Cable,AL,ARM	50	No.								





**TP CENTRAL ODISHA DISTRIBUTION LIMITED**  
(A Tata Power & Odisha Govt. joint venture)  
2nd Floor, IDCO Tower, Janpath Bhubaneshwar, Odisha 751022

NIT No.: TPCODL/P&S/72/2020-21

75	Supply 3CX 300Sqmm,11KV Indoor Termination Kit	2	No.								
76	Supply 3CX 400Sqmm,11KV Indoor Termination Kit	2	No.								
77	Supply 3CX 120Sqmm,11KV Indoor Termination Kit	2	No.								
78	Supply 3CX 185Sqmm,11KV Indoor Termination Kit	2	No.								
79	Supply 3CX 95Sqmm,11KV Indoor Termination Kit	2	No.								
80	Supply 3CX 400Sqmm,11KV Outdoor Termination Kit	2	No.								
81	Supply 3CX 300Sqmm,11KV Outdoor Termination Kit	2	No.								
82	Supply 3CX 185Sqmm,11KV Outdoor Termination Kit	2	No.								
83	Supply 3CX 120Sqmm,11KV Outdoor Termination Kit	2	No.								
84	3P 4 W 11 KV CT PT Combined Metering Unit Class of Accuracy 0.5 with CTR 20/5 A, with burden 15VA, PT with Burden 50VA	4	No								
85	Supply of 4C X 4Sqmm AL PVC Service cable un Arm for releasing 1PH	36720	Mtr								
86	Supply 3.5C * 35Sqmm LT PVC Cable Un armoured	12240	Mtr								
87	Supply 3.5C * 50qmm LT PVC Cable Un armoured	4896	Mtr								
88	Supply 3.5C * 95Sqmm LT PVC Cable Un armoured	4896	Mtr								





**TP CENTRAL ODISHA DISTRIBUTION LIMITED**  
(A Tata Power & Odisha Govt. joint venture)  
2nd Floor, IDCO Tower, Janpath Bhubaneshwar, Odisha 751022

NIT No.: TPCODL/P&S/72/2020-21

	using 40mm BHG metal with all labor and material except stay set , stay wire , stay insulator .										
102	Installation of Earthing of Support ( Coil Type )	88	No.								
103	Installation of Earth Pit, Charcoal, Salt etc. including construction of earthing chamber (Size: 2'x2') and RCC slab cover	100	No.								
104	Stringing of 80-100mm <sup>2</sup> AAAC	2.4	KM								
105	Painting of RS Joist Pole with fittings 2 coats of Al paint over a coat of red oxide primer including all Tools & Tackle	88	No.								
106	Installation, Testing and Commissioning of 11/0.4kV, 25kVA 3-Phase Distribution Transformer on existing structure as per TP Central Orissa Distribution Ltd. specification including loading, unloading, shifting/transportation from Division store to site /tent. Scope of work includes, jumpering/connection at HT and LT side , including minor site modification as per the TPCODL Standard Excluding Earthing	10	EA								
107	Installation, Testing and Commissioning of 11/0.4kV, 63kVA 3-Phase Distribution Transformer on existing structure	4	EA								



**TP CENTRAL ODISHA DISTRIBUTION LIMITED**  
(A Tata Power & Odisha Govt. joint venture)  
2nd Floor, IDCO Tower, Janpath Bhubaneshwar, Odisha 751022

NIT No.: TPCODL/P&S/72/2020-21

	as per TP Central Orissa Distribution Ltd. specification including loading, unloading, shifting/transportation from Division store to site /tent. Scope of work includes, jumpering/connection at HT and LT side , including minor site modification as per the TPCODL Standard Excluding Earthing									
108	Installation, Testing and Commissioning of 11/0.4kV, 100kVA 3-Phase Distribution Transformer on existing structure as per TP Central Orissa Distribution Ltd. specification including loading, unloading, shifting/transportation from Division store to site /tent. Scope of work includes, jumpering/connection at HT and LT side , including minor site modification as per the TPCODL Standard Excluding Earthing	4	EA							
109	Installation, Testing and Commissioning of 11/0.4kV, 250kVA 3-Phase Distribution Transformer on existing structure as per TP Central Orissa Distribution Ltd. specification including loading, unloading, shifting/transportation from site /tent. Scope of work includes	2	EA							



**TP CENTRAL ODISHA DISTRIBUTION LIMITED**  
(A Tata Power & Odisha Govt. joint venture)  
2nd Floor, IDCO Tower, Janpath Bhubaneshwar, Odisha 751022

NIT No.: TPCODL/P&S/72/2020-21

	earthing, jumpering/connection at HT and LT side as per the TPCODL Standard										
110	Installation of Outdoor Type Distribution Box with 40A MCCB with O/G for 11/0.4kV,25kVA Three Phase Transformer as per TP Central Orissa Distribution Ltd. specification	10	No								
111	Installation of Outdoor Type Distribution Box with 100A MCCB with O/G for 11/0.4kV,63kVA Three Phase Transformer as per TP Central Orissa Distribution Ltd. specification	4	No								
112	Installation of Outdoor Type Distribution Box (BOX DIST.WITH 160A 35KA TP MCCB 6 O/G) for 100KVA TRF	4	No								
113	Installation testing and commissioning of LT ACB 400 Amps with enclosure for 11/0.4KV 250KVA Threephase Transformer	2	No								
114	Installation of Outdoor Type Distribution Box(BOX DIST.WITH 500A 50KA TP MCCB 5 O/G) with MCCB for 11/0.4kV,250kVA Three Phase Transformer on existing structure as per TP Central Orissa Distribution Ltd. Specification	2	No								
115	Plinth for TFR 6ft hight (below GL2ft)x5ftx5ft	6	No								





**TP CENTRAL ODISHA DISTRIBUTION LIMITED**  
(A Tata Power & Odisha Govt. joint venture)  
2nd Floor, IDCO Tower, Janpath Bhubaneshwar, Odisha 751022

NIT No.: TPCODL/P&S/72/2020-21

116	Plinth for L.T. Distribution box 6ft high (below GL2ft)x5ftx5ft	2	No								
117	Installation of GI barbed wire anticlimbing device 2 Kg. Per support	176	Kg								
118	Installation of different size MS Channel for 50 S/S	5440	Kg								
119	Installation of different size MS Channel for DP in 6KM line	945.6	Kg								
120	Supply of GI Nut , Bolt & Washer of different sizes For line with DP for 6KM Line (70KG PER KM LINE)	168	Kg								
121	Supply of GI Nut , Bolt & Washer of different sizes For 50S/S ( 36KG Per s/s)	720	Kg								
122	Painting of RS Joist	88	No								
123	Dismantling of RS Joist pole(150x150mm/Rail pole) & return back to section store	8	No								
124	Dismantling of RS Joist pole(116x100mm)	8	No								
125	Dismantling of PSC pole (9mtr)	8	No								
126	Dismantling of 11KV 'V' Cross arm	8	No								
127	Dismantling of 11KV GI pin with insulator	24	No								
128	Dismantling of 11KV Disc insulator with HW Fitting	24	No								
129	Dismantling of MS Channel from 11KV Pole / DP	40	Kg								
130	Dismantling of 55mm <sup>2</sup> AAA Conductor	0.2	KM								



**TP CENTRAL ODISHA DISTRIBUTION LIMITED**  
(A Tata Power & Odisha Govt. joint venture)  
2nd Floor, IDCO Tower, Janpath Bhubaneshwar, Odisha 751022

NIT No.: TPCODL/P&S/72/2020-21

131	Dismantling of 80mm <sup>2</sup> AAA Conductor	0.2	KM								
132	Dismantling of 100mm <sup>2</sup> AAA Conductor	0.2	KM								
133	Sundries for survey tree cutting, small size nut bolt, Aluminium Binding wire / tape & Danger Board 4 Nos. etc. Line length of 1KM	2.4	LS								
134	Sundries for survey tree cutting, small size nut bolt, Aluminium. Binding wire / tape & Danger Board 4 Nos. etc. Substation upto 250KVA	20	LS								
135	Installation of Dead end clamp on LT Pole	24	No.								
136	Installation of Suspension clamp with I-Hook on LT Pole	72	No.								
137	Installation of Strain fittings on LT pole	19	No.								
138	Installation of Guy grip Dead end for LT Pole	19	No.								
139	Installation of Earthing Coil TO POLE	17	No.								
140	Laying / stringing of AB Cable( 3 x50 + 1x35mm <sup>2</sup> )	2400	Mtr.								
141	Laying / Stringing of AB Cable( 3 x35 + 1x25mm <sup>2</sup> )	2400	Mtr.								
142	Laying / Stringing of AB Cable( 3 x50 + 1x35mm <sup>2</sup> +1X16mm <sup>2</sup> )	2400	Mtr.								
143	Laying / Stringing of AB Cable( 3 x95 + 1x70mm <sup>2</sup> +1X16mm <sup>2</sup> )	2400	Mtr.								



**TP CENTRAL ODISHA DISTRIBUTION LIMITED**  
(A Tata Power & Odisha Govt. joint venture)  
2nd Floor, IDCO Tower, Janpath Bhubaneshwar, Odisha 751022

NIT No.: TPCODL/P&S/72/2020-21

144	Laying of Service cable 4sqmm x 2C	2	Mtr.								
145	Laying of 1.1KV 3.5C, 35Sqmm AL XLPE Cable	12240	Mtr.								
146	Laying of 1.1KV 3.5C, 150SqmmAL XLPE Cable	4896	Mtr.								
147	Laying of 1.1KV 4C, 240Sqmm AL XLPE Cable	4896	Mtr.								
148	Laying of 1.1KV 3.5C, 300Sqmm AL XLPE Cable	50	Mtr.								
149	Laying & EXCAVATION (1M Depth * 0.875M Width) of 11kV Armoured XLPE AL Cable 3CX95 sqmm/ 3CX120 sqmm in S/Sth. Trench/Tray as per TP Central Orissa Distribution Ltd. specification including testing of cable. Scope of work exclude fixing of Tray.BA will provide support during joint making by OEM of joint kit,no separate payment will be paid to BA for this support by BA	50	Mtr.								
150	Laying & Excavation (1M Depth * 0.875M) of 11kV Armoured XLPE AL Cable 3CX400/ 3X300 sqmm in S/Sth. Trench/Tray as per TP Central Orissa Distribution Ltd. specification including testing of cable. Scope of work exclude fixing of Tray.BA will provide support during joint making by	50	Mtr.								



**TP CENTRAL ODISHA DISTRIBUTION LIMITED**  
(A Tata Power & Odisha Govt. joint venture)  
2nd Floor, IDCO Tower, Janpath Bhubaneshwar, Odisha 751022

NIT No.: TPCODL/P&S/72/2020-21

	OEM of joint kit, no separate payment will be paid to BA for this support by BA										
151	Jointing of I/D or O/D of HT (11KV) UGC & including all related work and Approved Jointer	2	No.								
152	Indoor / outdoor Termination of 11 kV Armoured XLPE, AL Cable 3CX95 sqmm, 120Sqmm, 185Sqmm, 300SQMM, 400SQMM including consumable	2	EA								
153	Construction of 11KV RMU Plinth with Brick, Mortar, 12 mm cement plaster and painting with enamel paint.	2	EA								
154	Installation, Testing and Commissioning of 11kV 3-way Ring Main Unit on existing structure/foundation as per TP Central Orissa Distribution Ltd. specification including grouting, loading, unloading, shifting/transportation from site/tent. Scope of work includes pipe earthing, jumpering/connection and modification to foundation at Site	2	EA								
155	Installation, Testing and Commissioning of 1.1kV Feeder pillar with new structure/foundation as per TP Central Orissa Distribution Ltd. specification	2	EA								



**TP CENTRAL ODISHA DISTRIBUTION LIMITED**  
(A Tata Power & Odisha Govt. joint venture)  
2nd Floor, IDCO Tower, Janpath Bhubaneshwar, Odisha 751022

NIT No.: TPCODL/P&S/72/2020-21

	including grouting, loading, unloading, shifting/transportation from site/tent. Scope of work includes Pipe earthing, jumpering/connection and modification to foundation at Site										
156	Extension of one LBS in existing 11KV RMU structure specification including grouting, loading, unloading, shifting/transportation from site/tent. Scope of work includes earthing, jumpering/connection and construction / modification of foundation	2	EA								
157	Supply & Installation of HT Danger Board as per TP Central Orissa Distribution Ltd. specification	400	No.								
158	Transportation of various items from TPCODL store/site to other site or vice versa in TPCODL operational area - Truck with labours as required (price per Km). Scope of work also include loading and unloading of materials including heavy items like HT Panel, Transformer, Cable Drum, LT Board where loading, unloading is to be done with crane and crane will be paid separately .Transport	100	MT/KM								



**TP CENTRAL ODISHA DISTRIBUTION LIMITED**  
(A Tata Power & Odisha Govt. joint venture)  
2nd Floor, IDCO Tower, Janpath Bhubaneshwar, Odisha 751022

NIT No.: TPCODL/P&S/72/2020-21

	charges upto 50KM Per Metric Ton@Rs 16/KM										
159	Installation of Fire Extinguisher (5kG DCP) by means of proper hooks clamps etc. as required including providing of grouting material (cement etc.) and painting of hooks/clamps. Scope exclude supply of hook/clamp	40	No.								
160	Painting of Pole In Black & Yellow Strips/Zebra as per TP Central Orissa Distribution Ltd. specifications and indexing/numbering of Poles as per GIS format, scope also include site survey for GIS indexing and supply of ISI Marked good quality paint. (this item shall be paid for old poles only and where this not mentioned in scope)	88	No.								
161	Installation of 11KV CTPT Unit with all connection & Earthing as per TPCODL Drawing	5	No								
<b>Total All Inclusive Price</b>											

**Signature & Seal of the Bidder**

**NOTE:**

- The bidders are advised to quote prices strictly in the format attached.



**TP CENTRAL ODISHA DISTRIBUTION LIMITED**  
(A Tata Power & Odisha Govt. joint venture)  
2nd Floor, IDCO Tower, Janpath Bhubaneshwar, Odisha 751022

NIT No.: TPCODL/P&S/72/2020-21

- The bidder must fill each and every column of the format attached. ***Mentioning “extra/inclusive” in any of the column may lead for rejection of the price bid.***
- No cutting/ overwriting in the prices is permissible.
- The bidder should provide both supply of material as well as installation work. Individual bidding for supply or installation is not accepted.
- During execution of scheme major items like (Pole, Transformer, ABC Cable, HT Cable etc.) will be provided by TPCODL however in case it is required on work exigency same can be supplied by Vendor as per RC Price.
- The unit price to be indicated in col. No. 6 should be exclusive of taxes & duties which are to be indicated in separate columns meant for the purpose.
- **The bids will be evaluated commercially on overall BOQ basis (all-inclusive lowest cost) for the complete tender as calculated in Schedule of Items**
- **All the Bidder should participate for 10No’s of lot for supply as well as installation work. Selective bidding by the bidder for lot wise is not allowed.**
- The prices shall be FOR TPCODL Locations.



**TP CENTRAL ODISHA DISTRIBUTION LIMITED**  
(A Tata Power & Odisha Govt. joint venture)  
2nd Floor, IDCO Tower, Janpath Bhubaneshwar, Odisha 751022

NIT No.: TPCODL/P&S/72/2020-21

**ANNEXURE II**

**Technical Specifications**

**Attached:** Technical Specifications & reference drawing

Sl.No.	DESCRIPTION
1	SPECIFICATION FOR SUPPLY OF MATERIAL & CONSTRN/AGUMENTATION OF HT/LT LINES,SUBSTATION
2	SPECIFICATION FOR DANGER BOARD
3	SPECIFICATION FOR TOP BRACKET
4	SPECIFICATION FOR STAY SET ARRANGMRNT
5	SPECIFICATION FOR STAY WIRE 7/8 SWG
6	SPECIFICATION FOR TOP BRACKET
7	SPECIFICATION FOR LT ABC CONDUCTOR
8	SPECIFICATION FOR LT DISTRIBUTION BOX WITH MCCB
9	SPECIFICATION FOR 11KV / 33KV LA WITH PORCELAIN POLYMER INSULATOR
10	SPECIFICATION FOR 11KV AB SWITCH 200A WITH PORCELAIN / POLYMER INSULATOR
11	SPECIFICATION FOR 11KV AB SWITCH 400A WITH PORCELAIN / POLYMER INSULATOR
12	SPECIFICATION FOR 33KV AB SWITCH 400A WITH PORCELAIN / POLYMER INSULATOR
13	SPECIFICATION FOR EYE HOOK FOR LT PSC POLE
14	SPECIFICATION FOR 11KV DO FUSE UNIT
15	SPECIFICATION FOR 11KV ,22KV AND 33 KV UG CABLE JOINTS AND TERMINATIONS
16	SPECIFICATION FOR 11KV,33KV CABLES
17	SPECIFICATION FOR ALL ALUMINIUM ALLOY CONDUCTOR (AAAC) FOR 80SQMM AND 100SQMM
18	DRAWINGS





**TP CENTRAL ODISHA DISTRIBUTION LIMITED**  
(A Tata Power & Odisha Govt. joint venture)  
2nd Floor, IDCO Tower, Janpath Bhubaneshwar, Odisha 751022

NIT No.: TPCODL/P&S/72/2020-21

**ANNEXURE III**

**Schedule of Deviations**

*Bidders are advised to refrain from taking any deviations on this TENDER. Still in case of any deviations, all such deviations from this tender document shall be set out by the Bidders, Clause by Clause in this schedule and submit the same as a part of the **Technical Bid**.*

***Unless specifically mentioned in this schedule, the tender shall be deemed to confirm the TPCODL's specifications:***

<b>S. No.</b>	<b>Clause No.</b>	<b>Tender Clause Details</b>	<b>Details of deviation with justifications</b>

***By signing this document we hereby withdraw all the deviations whatsoever taken anywhere in this bid document and comply to all the terms and conditions, technical specifications, scope of work etc. as mentioned in the standard document except those as mentioned above.***

**Seal of the Bidder:**

**Signature:**

**Name:**



**TP CENTRAL ODISHA DISTRIBUTION LIMITED**  
(A Tata Power & Odisha Govt. joint venture)  
2nd Floor, IDCO Tower, Janpath Bhubaneswar, Odisha 751022

NIT No.: TPCODL/P&S/72/2020-21

**ANNEXURE IV**

**Schedule of Commercial Specifications**

***(The bidders shall mandatorily fill in this schedule and enclose it with the offer Part I: Technical Bid. In the absence of all these details, the offer may not be acceptable.)***

<b>S. No.</b>	<b>Particulars</b>	<b>Remarks</b>
1.	Prices firm or subject to variation (If variable indicate the price variation clause with the ceiling if applicable)	Firm / Variable
1a.	If variable price variation on clause given	Yes / No
1b.	Ceiling	----- %
1c.	Inclusive of GST	Yes / No (If Yes, indicate % rate)
1d.	Inclusive of transit insurance	Yes / No
2.	Delivery	Weeks / months
3.	Guarantee clause acceptable	Yes / No
4.	Terms of payment acceptable	Yes / No
5.	Performance Bank Guarantee acceptable	Yes / No
6.	Liquidated damages clause acceptable	Yes / No
7.	Validity (180 days) (From the date of opening of bid)	Yes / No
8.	Inspection during stage of manufacture	Yes / No
9.	Rebate for increased quantity	Yes / No (If Yes, indicate value)
10.	Change in price for reduced quantity	Yes / No (If Yes, indicate value)
11.	Covered under Small Scale and Ancillary Industrial Undertaking Act 1992	Yes / No (If Yes, indicate, SSI Reg'n No.)

**Seal of the Bidder:**

**Signature:**

**Name:**



**TP CENTRAL ODISHA DISTRIBUTION LIMITED**  
(A Tata Power & Odisha Govt. joint venture)  
2nd Floor, IDCO Tower, Janpath Bhubaneshwar, Odisha 751022

NIT No.: TPCODL/P&S/72/2020-21

**ANNEXURE V**

**Checklist of all the documents to be submitted with the Bid**

Bidder has to mandatorily fill in the checklist mentioned below:

<b>S. No.</b>	<b>Documents attached</b>	<b>Yes / No / Not Applicable</b>
1	EMD of required value	
2	Tender Fee as mentioned in this tender	
3	Signed copy of this tender as an unconditional acceptance	
5	Duly filled schedule of commercial specifications (Annexure IV)	
6	Sheet of commercial/technical deviation if any (Annexure III)	
7	Balance sheet for the last completed three financial years; mandatorily enclosing Profit & loss account statement	
8	Acknowledgement for Testing facilities if available (duly mentioned on bidder letter head)	
9	List of Machine/tools with updated calibration certificates if applicable	
10	Details of order copy (duly mentioned on bidder letter head)	
11	Order copies as a proof of quantity executed	
12	Details of Type Tests if applicable (duly mentioned on bidder letter head)	
13	All the relevant Type test certificates as per relevant IS/IEC (CPRI/ERDA/other certified agency) if applicable	
14	Project/supply Completion certificates	
15	Performance certificates	
16	Client Testimonial/Performance Certificates	
17	Credit rating/solvency certificate	
18	Undertaking regarding non blacklisting (On company letter head)	
19	List of trained/untrained Manpower	

**Seal of the Bidder:**

**Signature:**

**Name**



**TP CENTRAL ODISHA DISTRIBUTION LIMITED**  
(A Tata Power & Odisha Govt. joint venture)  
2nd Floor, IDCO Tower, Janpath Bhubaneswar, Odisha 751022

NIT No.: TPCODL/P&S/72/2020-21

**ANNEXURE VI**

**ACCEPTANCE FORM FOR PARTICIPATION IN REVERSE AUCTION EVENT**

*(To be signed and stamped by the bidder)*

In a bid to make our entire procurement process more fair and transparent, TPCODL intends to use the reverse auctions as an integral part of the entire tendering process. All the bidders who are found as technically qualified based on the tender requirements shall be eligible to participate in the reverse auction event.

**The following terms and conditions are deemed as accepted by the bidder on participation in the bid event:**

1. TPCODL shall provide the user id and password to the authorized representative of the bidder. *(Authorization Letter in lieu of the same shall be submitted along with the signed and stamped Acceptance Form).*
2. TPCODL will make every effort to make the bid process transparent. However, the award decision by TPCODL would be final and binding on the supplier.
3. The bidder agrees to non-disclosure of trade information regarding the purchase, identity of TPCODL, bid process, bid technology, bid documentation and bid details.
4. The bidder is advised to understand the auto bid process to safeguard themselves against any possibility of non-participation in the auction event.
5. In case of bidding through Internet medium, bidders are further advised to ensure availability of the entire infrastructure as required at their end to participate in the auction event. Inability to bid due to telephone line glitch, internet response issues, software or hardware hangs, power failure or any other reason shall not be the responsibility of TPCODL.
6. In case of intranet medium, TPCODL shall provide the infrastructure to bidders. Further, TPCODL has sole discretion to extend or restart the auction event in case of any glitches in infrastructure observed which has restricted the bidders to submit the bids to ensure fair & transparent competitive bidding. In case of an auction event is restarted, the best bid as already available in the system shall become the start price for the new auction.
7. In case the bidder fails to participate in the auction event due any reason whatsoever, it shall be presumed that the bidder has no further discounts to offer and the initial bid as submitted by the bidder as a part of the tender shall be considered as the bidder's final no regret offer. Any offline price bids received from a bidder in lieu of non-participation in the auction event shall be out-rightly rejected by TPCODL.
8. The bidder shall be prepared with competitive price quotes on the day of the bidding event.
9. The prices as quoted by the bidder during the auction event shall be inclusive of all the applicable taxes, duties and levies and shall be FOR at TPCODL site.
10. The prices submitted by a bidder during the auction event shall be binding on the bidder.
11. No requests for time extension of auction event shall be considered by TPCODL.
12. The original price bids of the bidders shall be reduced on pro-rata basis against each line item based on the final all-inclusive prices offered during conclusion of the auction event for arriving at Contract amount.

**Signature & Seal of the Bidder**



**TP CENTRAL ODISHA DISTRIBUTION LIMITED**  
(A Tata Power & Odisha Govt. joint venture)  
2nd Floor, IDCO Tower, Janpath Bhubaneswar, Odisha 751022

NIT No.: TPCODL/P&S/72/2020-21

**ANNEXURE VII**  
**SCOPE OF WORK**

**Scope of Work:**

1. Construction and Augmentation of 11 kV line, 1.1KV Line , U/G ( 1.1KV & 11KV) Cable laying Installation of DT's of different capacity (25Kva/63kva/100KVA/ 250KVA) in Plinth / pole mounted substation, RMU's installation, feeder pillar Box, 11KV CTPT Unit indoor & outdoor installation and other related Distribution work as per Annexure-1 at all over TPCODL area
2. Necessary statutory clearance from CEI of Orissa & any other authority for energizing the Circuit shall be in the scope of this tender. However, any statutory fees shall be borne by TPCODL on production of documentary evidence.
3. Bidders are requested to visit the site to understand the scope of work, site conditions and requirement prior to bidding. Hence, no price/time escalation shall be admissible on these accounts.
4. Prior erecting any extra items for these scheme- rates should be approved from competent authority.
5. The Bidder should have own Safety equipment like Neon Tester, Portable Earth, Earthing discharge rod, hard barricading, PPEs etc. along with Calibration certificates of all equipment.
6. Successful Bidder will ensure safety and Quality of work by ensuring deployment of competent man-power at site for whole duration and they have to submit the safety report and quality report to TPCODL E-I-C if required.
7. **Taking Over:** After commissioning of the complete system and final approval of Electrical Inspector & compliance to punch points observed to the satisfaction of Projects as per statutory requirements, system shall be handed over to TPCODL. In case taking over by TPCODL is delayed because of reasons not attributable to BA, taking over certificate will be issued by TPCODL & Retention money will be released. It would be considered to be deemed taking over by TPCODL after fully compliance by bidder to all applicable successful testing & compliance to Inspections carried out to the satisfaction of TPCODL Projects & further taking over is pending due to reasons attributable to TPCODL beyond one-month time. However, Retention amount shall be cleared after 03 months at the option of bidder after successful Pre commissioning & EI clearance subject to fulfilling of other terms of Tender (i.e Submission of EPBG etc.) & submission of undertaking from bidder to provide fullest support in future at the time of commissioning.
8. Permissions from road owning agencies & statutory clearances shall be taken by TPCODL, however full support shall be provided by bidder to achieve it.
9. There will be no price escalation given to bidder after issue the RO even if there is delay in the project due to ROW permission.
10. In case any additional material is to be asked to supply after finalization of scope of work in the detailed Engineering, the Extra price and the extension of delivery time (if applicable) as the case may be mutually agreed between TPCODL and Successful Bidder.



**TP CENTRAL ODISHA DISTRIBUTION LIMITED**  
(A Tata Power & Odisha Govt. joint venture)  
2nd Floor, IDCO Tower, Janpath Bhubaneswar, Odisha 751022

NIT No.: TPCODL/P&S/72/2020-21

11. Providing the steel barricading/ any other (as per site requirement) as per TPCODL specification will be in Bidder scope, TPCODL will not give any additional cost for this activity. This line item is not mentioned in Tender BOQ and no extra item will be paid to successful bidder in future for this activity.
12. Normal De-watering will be in bidder scope, TPCODL will not give additional cost for this activity, but if there will be huge de-watering or level of water is huge than prices for this activity will be decided mutually. In this case successful bidder has to provide the details back up for this activity.
13. Loading, Unloading & Transportation of all the scrap material to be stacked counted (where material supplied by BA) and loading unloading, transportation of this scrap to TPCODL site/Store as per direction of Engg. In-Charge will be in bidder scope.
14. Crane/ New Generation Hydra shall be used for loading, unloading, handling & erection of equipments at site. Normal Hydra shall not be used at site. In case of site related issues where crane or New Gen Hydra cannot be used due to site constraint or other reasons, the Normal Hydra can be used only post receipt of permission from TPCODL E-I-C.
15. Sign writing of equipments / poles where erection of such equipments is also in bidder scope shall be in bidder scope. No additional price shall be given to BA.
16. Providing Infrastructure and Supporting to Jointer for making the joints in HT/LT in O/H Line and underground line shall be in bidder Scope. This item shall not be paid additional.
17. Watch & Ward, de-watering (normal) shall be in bidder scope.
18. Wherever TPCODL specifications are not available relevant IS/IEC to be followed. All Drawings mentioned in the Tender Specification and other required for the completeness of the tender shall be submitted. Drawing submission process shall not be deemed complete if all the requirements are not complied during the submission of the same.
19. The successful bidder has to follow the Contract safety management (CSM) as per GCC. The penalty will be imposing to bidder for any safety violence as per CSM matrix.
20. The scope of supply items- includes design, Engineering, Manufacturing; testing, loading, unloading, transportation to site storage, preservation, insurance, along with supply of all accessories, tools, spares, O&M catalogs for successful ITC is in the scope of Bidder.
21. All required and applicable type tests has to be performed by supplier
22. All Bidders are requested to see the detail scope of work in long text of tender BOQ and also visit the site as per details mentioned in above schedule.



**TP CENTRAL ODISHA DISTRIBUTION LIMITED**  
(A Tata Power & Odisha Govt. joint venture)  
2nd Floor, IDCO Tower, Janpath Bhubaneshwar, Odisha 751022

NIT No.: TPCODL/P&S/72/2020-21

**ANNEXURE VIII**  
**GENERAL CONDITIONS OF CONTRACT**

**Attached:** General Conditions of Contract for Composite Orders

CONFIDENTIAL



**TP CENTRAL ODISHA DISTRIBUTION LIMITED**  
(A Tata Power & Odisha Govt. joint venture)  
2nd Floor, IDCO Tower, Janpath Bhubaneshwar, Odisha 751022

NIT No.: TPCODL/P&S/72/2020-21

## **ANNEXURE IX**

### **SAFETY POLICY AND SAFETY TERMS AND CONDITIONS**

#### **Definitions**

**Order Manager:** Order Manager is the TPCODL representative, who has the ownership of the given job under the signed contract.

**Service Provider/Contractor/Vendor:** An individual or an organization that provides services to TPCODL under a signed contract.

**Site Safety Management Plan:** It is the safety plan agreed between Contractor / Service provider and TPCODL. It will contain the entire job specific safety requirement and will be signed by the service provider.

**High Risk Job:** Any job which has significant health and safety risk associated to it. The list of high risk jobs has been identified at TPCODL level.

**Emergency:** A serious, unexpected, business discontinuity and often dangerous situation resulting into loss of revenue / property and requiring immediate action.





**TP CENTRAL ODISHA DISTRIBUTION LIMITED**  
(A Tata Power & Odisha Govt. joint venture)  
2nd Floor, IDCO Tower, Janpath Bhubaneswar, Odisha 751022

NIT No.: TPCODL/P&S/72/2020-21

## 1. Safety Policy



### HEALTH AND SAFETY POLICY

Tata Power is committed to provide safe and healthy working environment for the prevention of work related injuries and ill-health. Safety is one of our core values. We strive to be a leader in safety excellence in the global power and energy business. In pursuit of this, we are committed to the following:

- Maintain and continually improve our management systems to eliminate hazards and reduce health & safety risks to all our stakeholders.
- Incorporate appropriate health & safety criteria into business decisions for selection of plant and technology, performance appraisal of individuals and appointments in key positions.
- Comply and endeavour to exceed all applicable health & safety legal and other requirements
- Integrate health & safety procedures and best practices into every operational activity with assigned line-functional responsibilities at all levels.
- Involve our employees and business associates in maintaining a safe and healthy work environment through consultation and participation
- Inculcate safety culture by visible leadership and empowerment.
- Ensure required competency to enable our employees and business associates for working safely.
- ↳ Promptly report incidents, investigate, share crucial learnings and prevent recurrences.
- Influence our business associates in enhancing their health and safety standards and align with Tata Power's health & safety codes and practices.
- Set safety & health metrics as indicators of excellence, monitor progress and continually improve health and safety performance.

We shall ensure the availability of appropriate resources at all times to fully implement and communicate this policy to all stakeholders by suitable means and periodically review its relevance in continuously changing business environment.

(Praveer Sinha)  
CEO & Managing Director

Date: 11<sup>th</sup> March, 2019  
**TATA POWER**  
Lighting up Lives!





**TP CENTRAL ODISHA DISTRIBUTION LIMITED**  
(A Tata Power & Odisha Govt. joint venture)  
2nd Floor, IDCO Tower, Janpath Bhubaneshwar, Odisha 751022

NIT No.: TPCODL/P&S/72/2020-21

## **2. Safety Organization & Responsibilities**

### **2.1 Contractor Site Management and Supervision**

Each Contractor will be responsible for fulfilling all statutory and safety requirements as per the laws of the land and not limited to Factory Act, Electricity Act, Electricity Rules and Regulations, Shop and Establishment Act etc.

Each Contractor shall provide at least one competent full time safety supervisor for workforce of less than 100 numbers. When workforce ranges from 100 to 1000, the contractor has to provide at least one qualified safety officer and safety supervisors (reporting to the safety officer) in the ratio 1:100. For every 1000 addition in workforce, the contractor has to add 1 safety officer. The TPCODL Project Safety Manager will review and approve the appointment of all safety supervisors. Contractor/Subcontractor safety supervisors/officers will work with Tata Power Safety Managers and align themselves with Tata Power safety requirements.

Each Contractors'/Subcontractors' Site Manager is responsible, and will be held accountable, for the safety of their sub-contractors and workforce and for ensuring that all equipment, materials, tools and procedures remain in safety compliance at job site, including:

- Holding officer/supervisors accountable for safety and actively promote safe work performance.
- Participate in and cooperate with all safety program requirements to be implemented in order to meet Tata Power safety objectives.
- Ensure timely reporting of safety incidents, near misses, unsafe acts and conditions.
- Identify the training needs of its employees and maintain all safety training documents.
- Provide safety performance report at an agreed frequency.
- Stopping of unsafe work (acts and/or conditions) immediately, until corrective action be taken.

### **2.2 Contractor Supervisors and General Staff**

Contractors' site supervisors and general staff members in charge of job site functions such as field engineering, warehousing, purchasing, cost and scheduling, etc. are responsible for the safe performance of the work of those they supervise. They must set an example for their fellow employees by being familiar with applicable sections of the Site Safety program and ensuring that all site activities are performed with SAFETY as the primary objective.

Each site supervisor is responsible and will be held accountable for identifying, analyzing and eliminating or controlling all hazards through implementation of an aggressive, pro-active Health, Safety and Environmental Program from project inception through project completion. Each supervisor will proactively participate in the SHE program by observing, correcting unsafe acts, and recording these observations.

### **2.3 Contractor Workforce**



**TP CENTRAL ODISHA DISTRIBUTION LIMITED**  
(A Tata Power & Odisha Govt. joint venture)  
2nd Floor, IDCO Tower, Janpath Bhubaneshwar, Odisha 751022

NIT No.: TPCODL/P&S/72/2020-21

Contractor workforce must make safety a part of their job by following safety rules and regulations and by using all safeguards and safety equipment. They must take an active part in the Site Safety program to ensure their own safety and injury-free employment as well as being alert to unsafe practices of their fellow employees.

Every member of the workforce is expected to report for work without influence of any Drug/Alcohol. All employees are expected to report any hazardous conditions practices and behaviors in their work areas and correct where ever possible. Workforce is responsible for active participation in safety and health programs, suggestion systems, trainings and in immediate reporting of all injuries, any unsafe practices, conditions or incidents to their supervisors.

#### 2.4 Vendor/Contractor

Vendors/Contractor shall at all times comply with, and ensure that their workforce comply with all site safety rules and regulations. Specifically, with applicable provisions of the Tata Power Site Safety Management Plan, and all statutory safety rules and regulations.

### 3. Site Safety Rules and Procedures

The work in the safest possible manner can only happen when it has been carefully planned and all applicable procedures are followed. The Tata Power Safety Procedures are derived from Tata Power best practices and the applicable Government acts regulations. In each case, the most stringent regulation is used.

Following is the list of Tata Power's critical Safety Rules and Procedures. Contractor shall refer to approved Rules and Procedures for detailed requirements and ensure conformance.

#### 3.1 Lock Out and Tag Out Procedure

This procedure is intended to be used for the protection of Personnel while servicing or performing maintenance on equipment / pipeline / vessel / process systems. This is a general procedure that shall be used as the minimum requirements for isolation of equipment, pipelines, machines, system from all possible sources of hazardous energy and / or material such as Steam, Hot Water, Compressed Air, any other process fluid / chemical energy/Mechanical energy or Electrical energy. For complete procedure kindly refer Procedure Document No. TPSMS/CSP/LOTO/001 REV 01 available on official website of Tata Power ([www.tatapower.com](http://www.tatapower.com))

#### 3.2 Excavation Safety (Shoring and Sloping) Procedure

This procedure is developed to cover the safe practices required for shoring and sloping in excavation and trenching jobs. This procedure is developed to establish mandatory requirements for practices to protect personnel, property and equipment from hazards associated with above activities. For complete procedure kindly refer Procedure Document No TPSMS/CSP/EXS/002 REV 01 available on official website of Tata Power ([www.tatapower.com](http://www.tatapower.com))

#### 3.3 Confined Space Entry Procedure



**TP CENTRAL ODISHA DISTRIBUTION LIMITED**  
(A Tata Power & Odisha Govt. joint venture)  
2nd Floor, IDCO Tower, Janpath Bhubaneshwar, Odisha 751022

NIT No.: TPCODL/P&S/72/2020-21

This procedure outlines the steps required to perform the confined space entry and to protect personnel from the hazards of entering and conducting operations in confined spaces. For complete procedure kindly refer Procedure Document No –TPSMS/CSP/CSE/003 REV 01 available on official website of Tata Power ([www.tatapower.com](http://www.tatapower.com))

#### 3.4 Working at Height Procedure

This procedure describes the rules and procedures to protect employees from the hazards of working at heights.

This procedure is developed to cover the safe practices required for Working at Heights. This procedure is developed to establish mandatory requirements for practices to protect personnel from hazards associated in this area. For complete procedure kindly refer Procedure Document No –TPSMS/CSP/WAH/004 REV 01 available on official website of Tata Power ([www.tatapower.com](http://www.tatapower.com))

#### 3.5 Heavy Equipment Movement Safety Procedure

Heavy equipment lifting and movement is an activity involving loading, unloading, storage and movement from one place to another including lifting and erection or repairing of equipment with cranes or hoists. Material, machinery and equipment handling operations are being carried out by large capacity cranes and hoists, which make the job safer and faster. This procedure addresses the hazards and precautions associated with such equipment and their use. For complete procedure kindly refer Procedure Document No –TPSMS/CSP/HEMS/005 REV 01 available on official website of Tata Power ([www.tatapower.com](http://www.tatapower.com))

#### 3.6 Mobile Crane Safety Procedure

Mobile cranes are responsible for many incidents, injuries. Falling loads from mobile cranes pose a severe hazard to operators and nearby workers and property. Many types of cranes, hoists, and rigging devices are used for lifting and moving materials. To maintain safe, appropriate standards has to be adhered to and only qualified and licensed individuals shall operate these devices. For complete procedure kindly refer Procedure Document No –TPSMS/CSP/MCS/006 REV 01.

#### 3.7 Scaffold Safety Procedure

This procedure is developed to provide information on the safe erection, use, dismantling and maintenance of access scaffolding in the workplace. It is developed to establish mandatory requirements for practices to protect personnel from hazards associated with erection, use and dismantling of scaffolds. For complete procedure kindly refer Procedure Document No –TPSMS/CSP/SCAF/007 REV 01 available on official website of Tata Power ([www.tatapower.com](http://www.tatapower.com))

#### 3.8 Electrical Safety Procedure

The objective of these standards is to specify minimum mandatory requirements and advisory guidance for identifying and controlling hazards to ensure 'Zero Harm' with regard to operation maintenance and



**TP CENTRAL ODISHA DISTRIBUTION LIMITED**  
(A Tata Power & Odisha Govt. joint venture)  
2nd Floor, IDCO Tower, Janpath Bhubaneshwar, Odisha 751022

NIT No.: TPCODL/P&S/72/2020-21

testing of electrical equipment. For complete procedure kindly refer Procedure Document No-TPSMS/CSP/ELEC/010 REV 01 available on official website of Tata Power ([www.tatapower.com](http://www.tatapower.com))

### 3.9 Job Safety Analysis (JSA) Procedure

This objective of this procedure is to have a task based risk assessment process in place that identifies, evaluates and controls the risks associated with work activities, and as a result, prevents those involved in the task or those potentially affected by the task, from being harmed. For complete procedure kindly refer Procedure Document No- TPSMS/CSP/JSA/009 REV 01 available on official website of Tata Power ([www.tatapower.com](http://www.tatapower.com))

### 3.10 Fire Safety Management Procedure

Objective of This standard is to specify the minimum mandatory requirements and advisory guidelines to ensure prevention of fire related incidents and managing / controlling their impacts if they do occur. For complete procedure kindly refer Procedure Document No- TPSMS/CSP/FSM/011 REV 01

### 3.11 Permit To Work Procedure

Given the inherent hazards of the power generation and distribution industry, a significant number of TATA POWER operations and installations are critical. Work Permit (WP) System is an essential element in controlling the workplace risks in an effective manner. For complete procedure kindly refer Procedure Document No –TPSMS/CSP/PTW/008 REV 01 available on official website of Tata Power ([www.tatapower.com](http://www.tatapower.com))

### 3.12 Lift (Elevator) Safety Procedure

To provide safe operating procedure for taking control of lift car before entering and existing the pit of OTIS make elevators. For complete procedure kindly refer Procedure Document No – TPSMS/GSP/LIFT/001 REV 01 available on official website of Tata Power ([www.tatapower.com](http://www.tatapower.com))

### 3.13 Working on conveyor belt Procedure

This procedure is developed to cover the safe practices required for Working on live equipment and to protect personnel from hazards associated with it. For complete procedure kindly refer Procedure Document No – TPSMS/GSP/CONV/002 REV 01 available on official website of Tata Power ([www.tatapower.com](http://www.tatapower.com))

### 3.14 Handling Hazardous Materials Procedure

This Procedure is developed to provide procedure for recycling and / or safe disposal of used / waste batteries in compliance with all legislation. For complete procedure kindly refer Procedure Document No-TPSMS/GSP/HAZM/003 REV 01 available on official website of Tata Power ([www.tatapower.com](http://www.tatapower.com))

### 3.15 Material Handling and Storage Procedure





**TP CENTRAL ODISHA DISTRIBUTION LIMITED**  
(A Tata Power & Odisha Govt. joint venture)  
2nd Floor, IDCO Tower, Janpath Bhubaneshwar, Odisha 751022

NIT No.: TPCODL/P&S/72/2020-21

The purpose of this document is to provide procedures to assist the safe handling of materials (manual handling and mechanical handling). For complete procedure kindly refer Procedure Document No – TPSMS/GSP/MATL/004 REV 01 available on official website of Tata Power ([www.tatapower.com](http://www.tatapower.com))

### 3.16 Contractor Safety Management Procedure

The purpose of this document is to engage with contractors in a way to create safe work environment for everyone working for Tata Power. For complete procedure kindly refer Procedure Document No – TPSMS/GSP/CSM/015 REV 01 available on official website of Tata Power ([www.tatapower.com](http://www.tatapower.com))

The above procedures will be updated periodically and the updated version of the procedures as well as any additional critical procedure will be available on official website of Tata Power ([www.tatapower.com](http://www.tatapower.com)) for your reference.

## 4. Training and Capability Building

Safety Training and capability building of workforce is a major component of safety management program. All training required must be provided and documented as specified by Tata Power and Indian Regulations. Tata Power Safety Manager will audit contractors training and related documentation to assure its adequacy.

### 4.1 Tata Power Site Safety Orientation

All Tata Power contractor and subcontractor workforce is required to attend Tata Power Site Safety Orientation Training to receive a Safety Training Card, which is required to obtain a Gate Pass to the site, prior to entry.

This Safety Orientation Course will be for duration of minimum half day. The information provided during the orientation will include, but is not limited to following:

- Job rules, personal safety and conduct
- Hazards reporting
- Reporting of injuries
- Emergency procedures
- Safety Activities and Program including disciplinary measure and incentives.
- Critical safety procedure relevant to the job

### 4.2 Capability Building

Appropriate training such as L1, L2 & L3 is given to ensure that a jobholder, either supervisor or worker, is competent to do his/her job safely. The skill training is provided through TPSDI and other agencies authorized by Tata Power on the list of 15 procedures mentioned under safety procedure.

Contractor shall ensure that concerned workmen are provided with adequate training before he/she is allowed to execute the work.



**TP CENTRAL ODISHA DISTRIBUTION LIMITED**  
(A Tata Power & Odisha Govt. joint venture)  
2nd Floor, IDCO Tower, Janpath Bhubaneshwar, Odisha 751022

NIT No.: TPCODL/P&S/72/2020-21

An evaluation test will be conducted after the completion of the training. Those workmen employee who meet the minimum required competency will be provided with Gold Card which is valid for 3 years, post which the workmen has to reappear for the assessment. If the workman is not able to qualify the assessment, he/she will be given 3 additional attempts to clear in 3 month timeframe failing which he/she will not be allowed to work on high risk jobs.

**5. Pre-Employment and Periodic Medical check up**

Contractor shall arrange to conduct a pre-employment and periodic medical check-up for its entire workforce by Tata Power medical officer or Tata Power authorized medical officer. The contractor shall be able to produce the certificate prior to the employment. The contractor shall also organize to conduct periodical medical checkup (six monthly) for the following category of employees:

- Drivers (Check for Vision & Hearing)
- Equipment Operators (Check for Vision & Hearing)
- Workforce working at Height (Check for Vision, Hearing, Vertigo & Height Phobia)
- Workforce Handling the hazardous substances (Coal, ash and chemicals)
- Workforce in high decibel area (> 90 Decibel, Check for Hearing)
- Workforce, working in specific areas requiring specific medical attention should conduct the medical test as laid down in the respective Site Safety Management Plan.

**6. Safety Performance Evaluation and Penalties**

A certain percentage of the bill value will be retained against every running bill as safety performance retention. The amount will be released with the last invoice based on "Safety Performance score" attached in CSM-F-3 of CSM procedure. The amount is based on following table

Contract Value	Retention Amount (%)
Upto 10 Lakhs	2.5
10 – 50 lakhs	2
0.5 to 10 Cr	1.5
>10 Cr	1

- Safety performance Score will be monitored by the Order Manager every month.
- For the contract value of more than Rs 1 Cr or contract duration more than 12 months, the retention amount shall be released half yearly based on safety performance. For all remaining contracts, the retention amount will be released with the final bill.
- In case of job stoppage due to safety violations/ unsafe observations at the site, no time extension shall be given to the contractor, if such delays are attributable to contractor.



**TP CENTRAL ODISHA DISTRIBUTION LIMITED**  
(A Tata Power & Odisha Govt. joint venture)  
2nd Floor, IDCO Tower, Janpath Bhubaneshwar, Odisha 751022

NIT No.: TPCODL/P&S/72/2020-21

- In case of fatality, limb loss or loss of property, vendor has to pay for liability, legal, statutory and additional mutually agreed settlement charges imposed by the appointed committee. This charge is over and above the retention amount.
- The committee will finalize an amount between 5 -50 lakhs based on factors such as advise by statutory authorities, contract value and impact of accident etc.
- Safety performance bonus 1% (limiting to 50 lakhs) of the invoice value will be considered at the end of the job if the contractual safety performance score is 100%.
- During the progress of the work, concerned Supervisor/Engineer will visit and inspect the work site regularly and evaluate the safety performance of the contractor based on matrix attached herewith.
- Order Manager, divisional chief and SBU head have the authority to terminate the contract in case of three consecutive serious violations.

**7. Safety Performance Evaluation - CSM-F-3**

S. No.	Lead Indicators	Unit Of measurement	Target	Weightage
1	% of Employee certified in TPSDI/Authorized agency	%	50	10
2	CFSA score (Annexure 6.1)	Average Severity of Violations	1.49	20
3	Monthly inspection completed for Critical Equipments, lifting Tools & Tackles and hand tools used at site	%	80	5
4	Condition of tools, tackles and equipments	%	100	15
	<b>Lag Indicators</b>			
1	Number of Fatalities	No.	0	30
2	Number of Lost work day case (LWDC)	No.	0	10
3	Man-days Lost	No.	0	10

In addition to above evaluation criteria, for specific violations penalty shall be imposed on the contractors under following circumstances:





**TP CENTRAL ODISHA DISTRIBUTION LIMITED**  
(A Tata Power & Odisha Govt. joint venture)  
2nd Floor, IDCO Tower, Janpath Bhubaneswar, Odisha 751022

NIT No.: TPCODL/P&S/72/2020-21

Sr No	Description of violation	Severity	Penalty /
1.	Working without Permit	5	5000/-
2.	Untrained (TPSDI) worker on high-risk jobs.	5	5000/-
3.	Unhygienic/Bad condition of PPE	2	250/-
4.	Not following Tata Power Procedure & Standard	4	2000/-
5.	Unsafe Act/Condition of Severity 4	4	2000/-
6.	Unsafe Act/Condition of Severity 5	5	5000/-
7.	No Earthing of Electrical equipment	5	5000/-
8.	Damaged welding cable	5	5000/-
9.	Violation of Positive Isolation Procedure ( LOTO Not followed )	5	5000/-
10.	ELCB of more than 30 mA/ELCB not working	5	5000/-
11.	On/Off switch of welding m/c not working	5	5000/-
12.	Electric cable tied with metal wire	5	5000/-
13.	Leakage found DA hose / cylinder	5	5000/-
14.	Use of LPG	5	5000/-
15.	Use of Three-wheeler at the work site.	5	5000/-
16.	Starting the job without Tool Box Talk	5	5000/-
17.	Spatter falling on DA hose / Gas-line/ pathways / Equipment	5	5000/-
18.	No safety latch in crane hook	5	5000/-
19.	Load raised or swung over people or occupied areas of buildings	5	5000/-
20.	Persons standing in swing area of construction equipments.	5	5000/-
21.	Using damaged slings.	5	5000/-
22.	Unstable scaffolding/non standard Scaffolding in use	5	5000/-
23.	Handrails and mid-rails are missing	5	5000/-
24.	Safety Harness not anchored with lifeline/fixed structure	5	5000/-
25.	Fall arrestor not provided/ Not being used.	5	5000/-
26.	Double life line not used for working at height	5	5000/-
27.	No rubber mat in DB room	4	2000/-
28.	Water found accumulated in DB room/near welding machine.	4	2000/-
29.	Inserting electric cables into socket, without using plug.	4	2000/-
30.	Use of damaged electrical cable/two core cables.	4	2000/-
31.	Inflammable material found in D.B Room./ welding areas.	4	2000/-
32.	Loose material falling into excavated pit	4	2000/-
33.	Water logging into excavated pit	4	2000/-
34.	No / inadequate Barricade	4	2000/-



**TP CENTRAL ODISHA DISTRIBUTION LIMITED**  
(A Tata Power & Odisha Govt. joint venture)  
2nd Floor, IDCO Tower, Janpath Bhubaneshwar, Odisha 751022

NIT No.: TPCODL/P&S/72/2020-21

Sr No	Description of violation	Severity	Penalty /
35.	Undercut / cave-in found on sides of excavated pits	4	2000/
36.	Grinding wheel/ Coupling/ Piling winch/other rotating parts without guard	4	2000/
37.	The HMV/Mobile Crane operator does not having a valid HMV driving license.	4	2000/
38.	The loading area is not leveled properly.	4	2000/
39.	Ladder not anchored at top	4	2000/
40.	Opening found in working platform of scaffolding/floor	4	2000/
41.	Inadequate illumination at the working area	4	2000/
42.	Loose material lying on Gantry ,platform	4	2000/
43.	Cleaning body with Compressed Air.	3	500/-
44.	Gas Cylinders using without cap.	3	500/
45.	Gas Cylinders stored without securing	3	500/
46.	Bringing inside any other chemicals, apart from approved by Safety dept.	3	500/
47.	Using drum for sitting or accessing height.	3	500/
48.	Misusing emergency facilities like fire hydrant line/ hose box/ spray system/ eye wash etc.	3	500/
49.	No provision of Safety net where falling materials or tools may occurs	3	500/
50.	Taking electrical supply from non designated outlet (other than socket).	3	500/
51.	Restricted gangways due to unwanted materials.	3	500/
52.	Not reporting incident.	3	500/
53.	Entering into restricted area like switch yard/ hazardous storage etc.	3	500/
54.	Work without supervision	3	500/
55.	Parking of vehicle without applying wheel choke at right front-front and left rear-rear wheels other than passengers cars.	3	500/
56.	Vehicle without helper or co-driver.	3	500/
57.	Not wearing florescent safety jacket at site.	3	500/
58.	People travelling in load body of vehicle.	3	500/
59.	Parking of vehicles at non designated area.	3	500/
60.	Shifting heavy materials without guide ropes.	3	500/
61.	Using other than 24V lamp inside the confined space/Use of other than 24V lamps.	3	500/
62.	Angular/ starch loading/ lifting with Crane or hoist.	3	500/
63.	By passing the limit switch/ Safety Interlock.	3	500/
64.	Housekeeping activities on road without proper barricade.	3	500/





**TP CENTRAL ODISHA DISTRIBUTION LIMITED**  
(A Tata Power & Odisha Govt. joint venture)  
2nd Floor, IDCO Tower, Janpath Bhubaneshwar, Odisha 751022

NIT No.: TPCODL/P&S/72/2020-21

Sr No	Description of violation	Severity	Penalty /
65.	Trying to board or alit from running vehicle.	3	500/-
66.	Cylinder Valves of Gas cylinders not closed when not in use.	3	500/-
67.	Flash-back arrester not used.	3	500/-
68.	Trolley wheel found damaged.	3	500/-
69.	Guy ropes of required length on both sides of object are not used during movement with load.	3	500/-
70.	Scotch block/wedge not provide when the vehicle is parked.	3	500/-
71.	Suitable Trolley not provided to hold the cylinders.	3	500/-
72.	Locked First Aid box	3	500/-
73.	Caution boards, danger signs (luminescent /red) along with emergency contact number are not found displayed.	3	500/-
74.	Person found jumping barricading tape	3	500/-
75.	Stacking of pipes, pile casing , drums without chock blocks/wedges	3	500/-
76.	The terrain on which Heavy Equipment/Machinery moves is not reasonably hard.	3	500/-
77.	Without Safety Helmet at working sites	4	250/-
78.	Without Crash Helmet (on bikes)	4	500/-
79.	Without Full body double lanyard Safety Harness (for work at height)	5	5000/-
80.	Without Hand gloves - Material Handling, Welding, Cutting,	4	100/-
81.	Without Safety goggles/ face shield - Welding/Cutting /Grinding	5	5000/-
82.	Handling Chemical without PVC Apron	5	5000/-
83.	Smoking in prohibited area (Closed Go-downs, Storage of flammable material, Storage of Gas cylinders)	5	1000/-
84.	Sleeping at Work Place	3	100/-
85.	Driving beyond speed limit	3	1000/-
86.	Seat Belt While Driving (for front seat passengers and driver)	3	500/-
87.	Driving without license	4	1000/-
88.	Heavy Commercial vehicles without reverse horn	3	500/-
89.	Non functional Head light/ tail light and side indicators	3	100/-
90.	Using Mobile Phone During Driving	5	5000/-
91.	Poor visibility of registration number/ without registration number	3	100/-
92.	Broken/ without Side view mirror	3	100/-
93.	Over speeding above specified limit	3	500/-
94.	Broken/ Without Pressure gauge on Oxygen/ LPG / Acetylene cylinder.	3	500/-



**TP CENTRAL ODISHA DISTRIBUTION LIMITED**  
(A Tata Power & Odisha Govt. joint venture)  
2nd Floor, IDCO Tower, Janpath Bhubaneshwar, Odisha 751022

NIT No.: TPCODL/P&S/72/2020-21

Sr No	Description of violation	Severity	Penalty /
95.	Without Flash back arrestor on Industrial Acetylene & Oxygen cylinders.	5	5000/-
96.	Spillage of hazardous material/chemicals during transportation	4	2000/-
97.	Electrical equipment without Earthing/ ELCB/ Double Insulation Cable.	5	5000/-
98.	Lifting Tools & Tackles used without/ expired Test Certificates.	5	5000/-
99.	Housekeeping repeatedly not maintained		
100.	<ul style="list-style-type: none"><li>• First Time</li></ul>	3	Warning
101.	<ul style="list-style-type: none"><li>• Second Time</li></ul>	4	1000/-
102.	<ul style="list-style-type: none"><li>• Third Time</li></ul>	5	5000/-
103.	Serious Violation Of House Keeping (after 1 <sup>st</sup> or 2 <sup>nd</sup> warning to be decided by Project Manager depending on the severity)		Rs.10000/- and above
104.	Repeat Violation of same nature	5	5X Violation

CONFIDENTIAL



**TP CENTRAL ODISHA DISTRIBUTION LIMITED**  
(A Tata Power & Odisha Govt. joint venture)  
2nd Floor, IDCO Tower, Janpath Bhubaneshwar, Odisha 751022

NIT No.: TPCODL/P&S/72/2020-21

**ANNEXURE X**  
**TATA CODE OF CONDUCT**

The Owner abides by the Tata Code of Conduct in all its dealing with stake holders and the same shall be binding on the Owner and the Contractor for dealings under this Order/ Contract. A copy of the Tata Code of Conduct is available a tour website:

**<https://www.tatapower.com/pdf/aboutus/Tata-Code-of-Conduct.pdf>**

The Contractor is requested to bring any concerns regarding this to the notice of our Chief Procurement & Stores e-mail ID: [pkjain@tatapower.com](mailto:pkjain@tatapower.com).

CONFIDENTIAL



**TP CENTRAL ODISHA DISTRIBUTION LIMITED**  
(A Tata Power & Odisha Govt. joint venture)  
2nd Floor, IDCO Tower, Janpath Bhubaneshwar, Odisha 751022

NIT No.: TPCODL/P&S/72/2020-21

**ANNEXURE XI**  
**ENVIRONMENT & SUSTAINABILITY POLICY**



**CORPORATE ENVIRONMENT POLICY**

**Tata Power is committed to a clean, safe and healthy environment, and we shall operate our facilities in an environmentally sensitive and responsible manner. Our commitment to environmental protection and stewardship will be achieved by:**

- Complying with the requirements and spirit of applicable environmental laws and striving to exceed required levels of compliance wherever feasible
- Ensuring that our employees are trained to acquire the necessary skills to meet environmental standards
- Conserving natural resources by improving efficiency and reducing wastage
- Making business decisions that aim towards sustainable development
- Engaging with stakeholders to create awareness on sustainability

(Praveer Sinha)  
CEO & Managing Director

Date: 15<sup>th</sup> June, 2018

**TATA POWER**  
Lighting up Lives!





**TP CENTRAL ODISHA DISTRIBUTION LIMITED**  
(A Tata Power & Odisha Govt. joint venture)  
2nd Floor, IDCO Tower, Janpath Bhubaneshwar, Odisha 751022

NIT No.: TPCODL/P&S/72/2020-21



## **CORPORATE SUSTAINABILITY POLICY**

At Tata Power, our Sustainability Policy integrates economic progress, social responsibility and environmental concerns with the objective of improving quality of life. We believe in integrating our business values and operations to meet the expectations of our customers, employees, partners, investors, communities and public at large

- We will uphold the values of honesty, partnership and fairness in our relationship with stakeholders
- We shall provide and maintain a clean, healthy and safe working environment for employees, customers, partners and the community
- We will strive to consistently enhance our value proposition to the customers and adhere to our promised standards of service delivery
- We will respect the universal declaration of human rights, International Labour Organization's fundamental conventions on core labour standards and operate as an equal opportunities employer
- We shall encourage and support our partners to adopt responsible business policies, Business Ethics and our Code of Conduct Standards
- We will continue to serve our communities:
  - By implementing sustainable Community Development Programmes including through public/private partnerships in and around our area of operations
  - By constantly protecting ecology, maintaining and renewing bio-diversity and wherever necessary conserving and protecting wild life, particularly endangered species
  - By encouraging our employees to serve communities by volunteering and by sharing their skills and expertise
  - By striving to deploy sustainable technologies and processes in all our operations and use scarce natural resources efficiently in our facilities
  - We will also help communities that are affected by natural calamities or untoward incidence, or that are physically challenged in line with the Tata Group's efforts

The management will commit all the necessary resources required to meet the goals of Corporate Sustainability.

(Praveer Sinha)  
CEO & Managing Director

Date: 15<sup>th</sup> June, 2018

**TATA POWER**  
Lighting up Lives!



TP Central Odisha Distribution Limited	 TP CENTRAL ODISHA DISTRIBUTION LIMITED	SPECIFICATION FOR SUPPLY OF MATERIAL & CONSTRN/AGUMENTATION OF HT/LT LINES, SUBSTATION
NEG-SPEC-01		Date of Issue: 05/08/2020

# TECHNICAL SPECIFICATION FOR SUPPLY OF MATERIALS & CONSTRUCTION / AGUMENTATION OF HT/LT LINES , SUB-STATION

**TP Central Odisha Distribution Limited.**  
**Network Engineering Group**  
**2<sup>nd</sup> Floor, IDCO Tower**  
**Janpath, Bhubaneswar- 751022**

No.	Description	Prepared By & Date	Checked By & Date	Approved for Issue By & Date
		Anil Sah	Niranjan Khuntia	Pourush Garg
		05/08/2020	05/08/2020	05/08/2020



TP Central Odisha Distribution Limited	 TP CENTRAL ODISHA DISTRIBUTION LIMITED	SPECIFICATION FOR SUPPLY OF MATERIAL & CONSTRN/AGUMENTATION OF HT/LT LINES, SUBSTATION
NEG-SPEC-01		Date of Issue: 05/08/2020

## 1.0 NATURE OF WORK

The work covered by this Specification for construction of 11KV line, LT distribution lines, distribution Sub-station for releasing power supply to new consumer and agumentation of the existing network for diversion, heightening of HT lines due to low vertical clearance & re-route the power lines crossing at different locations. Electrical Inspection, testing, commissioning and dismantled the existing electrical network thereafter & returned the materials to TPCODL Utility store, handing over.

### Methodology:-

- The complete procedures for the execution of the project are explained herewith should be carried out by the executing agency;
- Detailed survey of Lines, substation followed by single line diagrams of different location enclosed and any modification or alternation required to complete the work, if require then the agency should prepare diagram with BOQ and get it approved from TPCODL Utility before execution within the estimated cost.
- Complete manufacture details, including shop testing & supply of materials from the approved vendors (materials which are to be supplied by the bidder) on prior approval of the TPCODL Utility.
- Providing Engineering & REC drawing, data, operational manual, etc wherever applicable for approval of TPCODL Utility.
- All required materials you have to supply cover under the contract.
- Packing and transportation of materials from the manufacturer's works to the site.
- Receipt, storage, preservation and conservation of equipment at the site.
- Pre-assembly, if any, erection testing and commissioning of all the equipment;
- Reliability tests and performance and guarantee tests on completion of commissioning;
- Loading, unloading and transportation as required.
- Construction of LT/HT lines & Sub-stations for releasing power supply to new consumer.
- RS Joist poles are to be used for construction of new HT lines & heightening the existing line by installing interposing poles.

No.	Description	Prepared By & Date	Checked By & Date	Approved for Issue By & Date
		Anil Sah	Niranjan Khuntia	Pourush Garg
		05/08/2020	05/08/2020	05/08/2020

TP Central Odisha Distribution Limited		SPECIFICATION FOR SUPPLY OF MATERIAL & CONSTR/AGUMENTATION OF HT/LT LINES, SUBSTATION
NEG-SPEC-01	TP CENTRAL ODISHA DISTRIBUTION LIMITED	Date of Issue: 05/08/2020

- Installation of PSC poles and existing poles are to be used for stringing of LT AB cable.
- Fencing of S/S to be done with Barbed wire / FRP Fencing / TPCODL standard fencing. .
- Concreting & coupling of all RS Joist poles.
- Conceting of all PSC pole
- Testing, Commissioning of lines / installations
- Getting the lines inspected by Electrical Inspector after completion of work including deposit of required inspection fees .
- All expenditure towards inspection of materials at manufacturers site and inspection of work after completion shall be borne by the executive agency.
- Dismantling of existing electrical network and return of these dismantled items at the TPCODL Utility's stores including transportation cost.

## **2.0 Detail Technical Specification specified :**

### **2.0.1 SURVEY (detail & check, estimating of quantities & spotting of Poles location)**

Walk over survey shall have to be carried out to ascertain the location wise nature of work to be executed. Bidder should do the field survey of the site before executing the project.

**2.0.2 GENERAL:** The Right of way shall be resolved by the contractor and all expenses there of shall be borne by him. However, TPCODL Utility shall render all helps in co-ordination with law and order and forest department for solving the same.

**2.0.3** Provisional quantities/numbers of different types of work have been estimated and indicated in the BOQ Schedule given. However final quantities for work shall be as determined by the successful bidder, on completion of the detail survey.

**2.0.4** After completing the detailed survey, the contractor shall submit the final survey report for approval of the employer.

### **2.10 Final Checking, Testing and Commissioning**

After stringing & installation have been done as approved by the engineer, to ensure that everything is complete in all respects, the works shall be thoroughly inspected keeping in view the following main points.

No.	Description	Prepared By & Date	Checked By & Date	Approved for Issue By & Date
		Anil Sah	Niranjan Khuntia	Pourush Garg
		05/08/2020	05/08/2020	05/08/2020

TP Central Odisha Distribution Limited		SPECIFICATION FOR SUPPLY OF MATERIAL & CONSTRN/AGUMENTATION OF HT/LT LINES, SUBSTATION
NEG-SPEC-01	TP CENTRAL ODISHA DISTRIBUTION LIMITED	Date of Issue: 05/08/2020

All the bolts and nuts should be of hot dip galvanized materials as per relevant IS.

The stringing of the cable has been done as per the approved sag and desired clearances are achieved.

No damage, minor or major to the cable, messenger wire and accessories

The contractor shall submit a report to the above effect to the Engineer in Charge, who shall inspect and verify the correctness of the report. In case it is noticed that some or any of the above is not fulfilled, the engineer shall get such items rectified by the contractor no extra cost to the purchaser. After final checking, the line shall be tested for insulation resistance in accordance with IS 1255:1983.

All arrangements for such testing or any other test desired by the Engineer-in-charge shall be done by the contractor and necessary labour, transport and equipment shall be provided by him. Any defect found out as a result of such tests shall be rectified by the contractor, forthwith at no extra cost to the purchaser.

In addition to the above, the contractor shall be responsible for testing and ensuring that the total and relative sags of the cable as within the specified tolerance. Such tests shall be carried out at selected points along the route as required by the Engineer-in-charge and the contractor shall provide all necessary equipment and labour to enable the tests to be carried out. After satisfactory test on the line and approval by the Engineer in Charge, the line shall be energized at full operating voltage before handing over. The cable shall be megger tested before and after jointing. The AB cable shall be tested for.

- i) Continuity of messenger wire and conductors
- ii) Absence of cross phasing
- iii) Insulation resistance to earth
- iv) Insulation resistance between conductors
- v) DC Resistance
- vi) Capacitance

No.	Description	Prepared By & Date	Checked By & Date	Approved for Issue By & Date
	Specifications for PSC Pole	Anil Sah	Niranjan Khuntia	Pourush Garg
		05/08/2020	05/08/2020	05/08/2020

TP Central Odisha Distribution Limited		SPECIFICATION FOR SUPPLY OF MATERIAL & CONSTR/AGUMENTATION OF HT/LT LINES, SUBSTATION
NEG-SPEC-01	TP CENTRAL ODISHA DISTRIBUTION LIMITED	Date of Issue: 05/08/2020

As per the latest issue IS 1255:1983 and as per manufacturer's instructions. Sufficient backfilled earth covers each foundation pit and is adequately compacted.

All poles are used strictly according to final approved drawing and are free of any defect or damage whatsoever.

The stringing of the conductors and earth wire has been done as per the approved sag and tension charts and desired clearances are clearly available.

All conductor and messenger wire accessories are properly installed.

The insulation of the line as a whole is tested by the Contractor through provision of his own equipment, labour etc., to the satisfaction of the TPCODL Utility.

### **3.0 JOIST POLES / PSC POLES**

For the 11KV and LT lines and sub-stations the conventional RS Joist / PSC poles may be used. The materials must conform to IS: 800. All the test on materials and fabrication etc will be as per the relevant Indian standards.

### **4.0 ERECTION WORK**

When the survey is approved, the contractor shall submit to the employer a complete detail schedule of all materials to be used in the line. Size and length of conductor etc. are also to be given in the list. This schedule is very essential for finalizing the quantities of all line materials. The contractor shall furnish the same.

### **SCHEDULE OF ERECTION PROGRAMME**

After due approval of the detailed and check survey, the contractor shall submit to the employer a complete detailed schedule of erection programme with a Bar-Chart for construction of the lines indicating there in the target date of completion.

### **5.0 CONSTRUCTION OF FOUNDATION FOR JOIST/ PSC POLES**

- **ERECTION OF POLE, CONCRETING OF POLES AND COMPACTION OF SOIL**

5.1 Drawing for the excavation of pits, Foundation of both wet and Black cotton soil is enclosed which are to be adopted. If better design with less volume approved or tested by any other distribution agencies will also be acceptable.

No.	Description	Prepared By & Date	Checked By & Date	Approved for Issue By & Date
		Anil Sah	Niranjan Khuntia	Pourush Garg
		05/08/2020	05/08/2020	05/08/2020

TP Central Odisha Distribution Limited	 TP CENTRAL ODISHA DISTRIBUTION LIMITED	SPECIFICATION FOR SUPPLY OF MATERIAL & CONSTRN/AGUMENTATION OF HT/LT LINES, SUBSTATION
NEG-SPEC-01		Date of Issue: 05/08/2020

5.2 Following arrangement shall be adopted for proper erection of poles and properly compacting of the soil around the base / foot of the poles, under this package.

5.3 Excavation has to done as per the drawing to the required depth and size. After final excavation the pit should be dressed properly so that uneven portion and loose soil should be removed before PCC (M-7.5) i.e 1:4:8 of thickness 75 mm is laid. The base footing of the pole concreting RCC (M-12.5) i.e 1:3:6 has to be done by proper alignment and verticality.

5.4 The verticality and leveling of pole/structure should be done by the help of plum bob or with theodolite and leveling instrument.

6.0 **CEMENT CONCRETE AND BACK FILLING etc.**

A) **Materials**

All materials whether to be consumed in the work or used temporarily shall conform to relevant IS specification, unless stated otherwise, and shall be of the best approved quality.

B) **Cement**

Cement to be used in the work under the contract shall generally conform to IS:269/455-1989. Cement bags shall be stored by the contractor in a water tight well ventilated store sheds on raised wooden platform (raised at least 150 mm above ground level) in such a manner as to prevent deterioration due to moisture or intrusion of foreign matter. Cements to be used within three months from the date of manufacture. Sub-standard or partly set cement shall not be used and shall be removed from the site by the contractor at his cost.

C) Coarse Aggregates i.e Stone chips or stone ballast. For M15 concrete (mix 1:2:4) the aggregate will be in the ranges from 12mm to 20mm.size and for M7.5 concrete (mix 1:4:8) these will be from 25mm to 40mm size.

D) **Pole erection**

No.	Description	Prepared By & Date	Checked By & Date	Approved for Issue By & Date
		Anil Sah	Niranjan Khuntia	Pourush Garg
		05/08/2020	05/08/2020	05/08/2020

TP Central Odisha Distribution Limited		<b>SPECIFICATION FOR SUPPLY OF MATERIAL &amp; CONSTRN/AGUMENTATION OF HT/LT LINES, SUBSTATION</b>
NEG-SPEC-01	TP CENTRAL ODISHA DISTRIBUTION LIMITED	Date of Issue: 05/08/2020

After proper alignment, checking of verticality and leveling, the pole or structure should be properly tied before placing of base concrete of required height. Again the verticality and leveling should be checked.

E)The PCC pedestal concrete (M-12.5) is to be done by providing good quality of shutters, so that there will no leakage of cement slurry during concreting. The cooping height should be 450 mm above the existing ground level . The top portion of the cooping should be made tapered.

F. The back filling of locations should be done by using the excavated soil only in layers (each layer should not be more than 500 mm) by putting water and ramming by using wooden rammers. In no case stone of size more than 75mm used for back filling. Back-filling has to be done 75mm above ground level or as specified.6.

## 7.0 TECHNICAL SPECIFICATION OF R.S Joist Pole

### 1.0 Scope of Work:

This specification covers design, manufacture, testing and supply of 150x150mm RS Joist designed for a working load of 346kg. The bidder should enclose Performance Certificates from the above users, issued in favour of the Sub Vendor / manufacturer, as proof of successful operation in field.

### Applicable Standards:

This specification covers the manufacturing, testing before dispatch and delivery of following R.S Joists

SI No	<b>150x150mmRS Joist</b>	
1	150 x 150 mm R.S. Joist length:-13mtr,11 mtr .34.6kg/mtr	MT
SI No	<b>116x100mm RS Joist</b>	
1	116 x 100 mm R.S. Joist length:- 9mtr. 23kg/mtr	MT

No.	Description	Prepared By & Date	Checked By & Date	Approved for Issue By & Date
		Anil Sah	Niranjana Khuntia	Pourush Garg
		05/08/2020	05/08/2020	05/08/2020

TP Central Odisha Distribution Limited		<b>SPECIFICATION FOR SUPPLY OF MATERIAL &amp; CONSTRN/AGUMENTATION OF HT/LT LINES, SUBSTATION</b>
NEG-SPEC-01	TP CENTRAL ODISHA DISTRIBUTION LIMITED	Date of Issue: 05/08/2020

## 2.0 Standards:

The R.S Joists shall comply with the requirements of latest issue of IS – 2062 Gr – A except where specified otherwise.

## 3.0 Climatic Conditions :

The climatic conditions at site under which the store shall operate satisfactory, are as follows

Maximum Ambient Temperature	50° c
Average daily Ambient temperature	40°c
Minimum Ambient Temperature	0° c
Maximum rain fall per annum	2000mm
Maximum temperature of air in shade	45° c
Maximum ambient temperature	45° c
Maximum humidity	100%
Av. No. of thunder storm days per annum	70%
Av. No. of dust storm per annum	20
Av. Rain fall per annum	150mm

## 4.0 Rolled Steel Joists

The Rolled Steel joist (RSJ) support structures shall be fabricated from mild steel, grade A and in lengths dictated by design parameters .The joists, may include, but shall not be limited to the size i.e.150 X 150 mm & 116 x 100mm

### 4.1 Dimensions and Properties

RSJ DESIGNATION	150 x 150 mm ISHB
Length of Joist in Mtr with +100mm/- 0% Tolerance	13mtr,11mtr
Weight kg/m with±2.5% Tolerance	34.6
Sectional Area (cm <sup>2</sup> )	39.00

No.	Description	Prepared By & Date	Checked By & Date	Approved for Issue By & Date
		Anil Sah	Niranjana Khuntia	Pourush Garg
		05/08/2020	05/08/2020	05/08/2020



TP Central Odisha Distribution Limited		SPECIFICATION FOR SUPPLY OF MATERIAL & CONSTRN/AGUMENTATION OF HT/LT LINES, SUBSTATION
NEG-SPEC-01	TP CENTRAL ODISHA DISTRIBUTION LIMITED	Date of Issue: 05/08/2020

Depth(D) of Section (mm) with +3.0mm/ -2.0mm Tolerance as per IS 1852-1985	150.00
Width (B)of Flange(mm) ±4.0mm Tolerance for 150 x 150 mm ISHB IS 1852-1985	150.00
Thickness of Flange(Tf) (mm) with±1.5mm Tolerance	9.00
Thickness of Web(Tw) (mm) with±1.0mm Tolerance	8.40
Corner Radius of fillet or root (R1) (mm)	8.00
Corner Radius of Tow (R2) (mm)	4.00

Moment of Inertia Ixx (cm <sup>4</sup> ) Iyy (cm <sup>4</sup> )	1540.00 460.00
Radius of Gyration (cm) Rxx	6.29
Ryy	3.44
Flange Slope(α) in Degree	94.0
Tolerance in Dimension	As perIS:1852

#### 4.2 MECHANICAL PROPERTIES:

Tensile Test :	Requirement as per IS:2062/1999 Grade-A
Yeild Stress(MPa)	Min250
Tensile Strength(MPa)	Min410
Lo=(5.65VSo)Elongation%	Min23
Bend Test	Shall not Crack

#### 4.3. CHEMICAL PROPERTIES:

No.	Description	Prepared By & Date	Checked By & Date	Approved for Issue By & Date
		Anil Sah	Niranjan Khuntia	Pourush Garg
		05/08/2020	05/08/2020	05/08/2020



TP Central Odisha Distribution Limited		<b>SPECIFICATION FOR SUPPLY OF MATERIAL &amp; CONSTRN/AGUMENTATION OF HT/LT LINES, SUBSTATION</b>
NEG-SPEC-01	TP CENTRAL ODISHA DISTRIBUTION LIMITED	Date of Issue: 05/08/2020

Chemical Composition	Requirement as per IS:2062/ 1999 Grade-A	Permissible variation over the Specified
Grade	A	-
Chemical Name	Fe-410W A	-
Carbon(%Max.)	0.23	0.02

Manganese(%Max.)	1.5	0.05
Sulphur(%Max.)	0.050	0.005
Phosphorous(%Max.)	0.050	0.005
Silicon(%Max.)	0.40	0.03
Carbon Equivalent(%Max.)	0.42	-
Deoxidation Mode	Semi-killed or killed	-
Supply condition	As rolled	-

- However, In case of any discrepancy between the above data & the relevant IS Standard, the values indicated in the IS shall prevail. The Acceptance Tests shall be carried out as per Relevant IS standard.
- RS Joists of Specific Weight 34.6kg/mtr with length 15mtr, 13mtr,11mtr pole a with specified weight in MT shall have to be supplied as per IS:2062;2006 Grade "A" , IS:808;1989/2001, IS1608:1995 & IS:12779-1989 and their latest amendment if any complying the required Dimension, Weight, Chemical & Mechanical properties.confirming to the relevant IS, as per the Tolerance given Below

### 5.3.APPLICABLE TOLLERANCES :

1. Length of each pole = + 100mm / - 0 % As per relevant IS: 12779-1989  
(With proportionate change in no of Poles)
2. Specific Weight of RS Joists =  $\pm 2.5\%$  As per relevant IS:1852/1985
3. Weight for whole lot of supply for all categories =  $\pm 3.0\%$  As per relevant IS: 12779-1989 for both type of RS Joists.

No.	Description	Prepared By & Date	Checked By & Date	Approved for Issue By & Date
		Anil Sah	Niranjan Khuntia	Pourush Garg
		05/08/2020	05/08/2020	05/08/2020

TP Central Odisha Distribution Limited		SPECIFICATION FOR SUPPLY OF MATERIAL & CONSTRN/AGUMENTATION OF HT/LT LINES, SUBSTATION
NEG-SPEC-01	TP CENTRAL ODISHA DISTRIBUTION LIMITED	Date of Issue: 05/08/2020

#### 6.0. EMBOSSING ON EACH R.S JOIST:

Following distinct non-erasable embossing is to be made on each R.S Joists .

- Name & Logo of the Manufacturer.
- B.I.S Logo (ISI Mark) if applicable.
- Size of the R.S Joist

#### 7.0 GUARANTEED TECHNICAL PARTICULAR (RS JOISTS sizes 150x150mm)

(To be submitted along with offer)

##### Dimensions and Properties :

PARTICULARS	Specification	Specification By the Bidder
Length of Joist in Mtr with +100mm/-0% Tolerance	13mtr ,10 & 11Mtr,9mtr	
Weight kg/m with±2.5% Tolerance	34.6	
Sectional Area (cm <sup>2</sup> )	39.00	
Depth(D) of Section (mm) with +3.0mm/ - 2.0mm Tolerance as	150.00	
Width (B)of Flange (mm) with ±2.5mm Tolerance for116 x 100 mm ISMB & ±4.0mm Tolerance for 150 x 150 mm ISHB IS 1852-1985	150.00	
Thickness of Flange (Tf) (mm) with±1.5mm	9.00	
Thickness of Web(Tw) (mm) with±1.0mm Tolerance	8.40	
Corner Radius of fillet or root (R1) (mm)	8.00	

No.	Description	Prepared By & Date	Checked By & Date	Approved for Issue By & Date
		Anil Sah	Niranjan Khuntia	Pourush Garg
		05/08/2020	05/08/2020	05/08/2020

TP Central Odisha Distribution Limited		<b>SPECIFICATION FOR SUPPLY OF MATERIAL &amp; CONSTRN/AGUMENTATION OF HT/LT LINES, SUBSTATION</b>
NEG-SPEC-01	TP CENTRAL ODISHA DISTRIBUTION LIMITED	Date of Issue: 05/08/2020

Corner Radius of Tow (R2) (mm)	4.00	
Moment of Inertia Ixx (cm4) Iyy (cm4)	1540.00 460.00	
Radius of Gyration (cm) Rxx	6.29	
Modulus of Section Zxx(cm3) Zyy(cm3)	205 60.2	
Flange Slope( $\alpha$ ) in Degree	94.0	
Tolerance in Dimension	As per IS:1852	
Distinct Non-Erasable Embossings to be made on each R.S. Joist	a) Name & Logo of the	

**GUARANTEED TECHNICAL PARTICULAR (RS JOISTS sizes 116x100mm)**

(To be submitted along with offer)

**Dimensions and Properties :**

PARTICULARS	Specification	Specification By the Bidder
Length of Joist in Mtr with +100mm/-0% Tolerance	9Mtr, 10Mtr, 11Mtr	
Weight kg/m with $\pm 2.5\%$ Tolerance	23kg	
Sectional Area (cm <sup>2</sup> )	29.29	
Depth(D) of Section (mm) with +3.0mm/ - 2.0mm Tolerance as	116	
Width (B)of Flange (mm) with $\pm 2.5\text{mm}$ Tolerance for 116 x 100 mm ISMB & $\pm 4.0\text{mm}$ Tolerance for 150 x 150 mm ISHB IS 1852-1985	100	

No.	Description	Prepared By & Date	Checked By & Date	Approved for Issue By & Date
		Anil Sah	Niranjana Khuntia	Pourush Garg
		05/08/2020	05/08/2020	05/08/2020

TP Central Odisha Distribution Limited		SPECIFICATION FOR SUPPLY OF MATERIAL & CONSTRN/AGUMENTATION OF HT/LT LINES, SUBSTATION
NEG-SPEC-01	TP CENTRAL ODISHA DISTRIBUTION LIMITED	Date of Issue: 05/08/2020

Thickness of Flange (Tf) (mm) with±1.5mm	10	
Thickness of Web(Tw) (mm) with±1.0mm Tolerance	8.50	
Corner Radius of fillet or root (R1) (mm)	15	
Corner Radius of Tow (R2) (mm)	3	
Moment of Inertia Ixx (cm4) Iyy (cm4)	643.80 143.50	
Radius of Gyration (cm) Rxx , Ryy	4.69 2.21	
Modulus of Section Zxx(cm3) Zyy(cm3)	111 28.7	
Flange Slope( $\alpha$ ) in Degree		
Tolerance in Dimension	As per IS:1852	
Distinct Non-Erasable Embossings to be made on each R.S. Joist	a) Name & Logo of the Manufact urer.  b) B.I.S Logo (ISI Mark) if applicable. Size	

## 8. PSC Pole (9Mtr x 300 Kg)

### TECHNICAL SPECIFICATIONS

#### 1)Qualification Criteria of Sub Vendor / Manufacturer:-

No.	Description	Prepared By & Date	Checked By & Date	Approved for Issue By & Date
		Anil Sah	Niranjan Khuntia	Pourush Garg
		05/08/2020	05/08/2020	05/08/2020

TP Central Odisha Distribution Limited		SPECIFICATION FOR SUPPLY OF MATERIAL & CONSTRN/AGUMENTATION OF HT/LT LINES, SUBSTATION
NEG-SPEC-01	TP CENTRAL ODISHA DISTRIBUTION LIMITED	Date of Issue: 05/08/2020

The prospective bidder may source PSC Poles from manufacturers. The bidder should enclose Performance Certificates from the users, issued in favour of the Sub Vendor / manufacturer, as proof of successful operation in field.

**Applicable Standard:**

The Poles shall comply with latest standards as under:

REC Specification No. 15/1979, REC Specification No. 24/1983, IS 1678, IS 2905, IS 7321.

**II) Materials:**

**Cement**

Cement to be used in the manufacture of pre-stressed concrete poles shall be ordinary for rapid hardening Portland cement confirming to IS: 269-1976 (Specification for ordinary and low heat Portland cement) or IS: 8041 E-1978 (Specification for rapid hardening Portland cement).

**Aggregates**

Aggregates to be used for the manufacture of pre-stressed concrete poles shall confirm to IS:383 (Specification for coarse and fine aggregates from natural sources for concrete) .The nominal maximum sizes of aggregates shall in no case exceed 12 mm.

**Water**

Water should be free from chlorides, sulphates, other salts and organic matter. Potable water will be generally suitable.

**Admixture**

Admixture should not contain Calcium Chloride or other chlorides and salts which are likely to promote corrosion of pre-stressing steel. The admixture shall conform to IS: 9103

**Pres-Stressing Steel**

Pre-stressing steel wires including those used as un tensioned wires should conform to IS:1785 (Part-I) (Specification for plain hard-drawn steel wire for pre-stressed concrete, Part-I cold drawn stress relieved wire).IS:1785 (Part-II)(Specification for plain hard-drawn steel wire) or IS:6003 (Specification for indented wire for pre-stressed concrete).The type design given in the annexure are for plain wires of 4 mm diameter with a guaranteed ultimate strength of 160 kg/mm<sup>2</sup>. All pre-stressing steel shall be free from splits, harmful scratches, surface flaw, rough, aged and imperfect edges and other defects likely to impair its use in pre-stressed concrete.

**Concrete Mix**

Concrete mix shall be designed to the requirements laid down for controlled concrete (also called design mix concrete) in IS: 1343-1980 (Code of practice for pre-stressed concrete) and IS: 456 – 1978 (Code of practice for plain and reinforced concrete) subject to the following special conditions:

No.	Description	Prepared By & Date	Checked By & Date	Approved for Issue By & Date
		Anil Sah	Niranjan Khuntia	Pourush Garg
		05/08/2020	05/08/2020	05/08/2020

TP Central Odisha Distribution Limited		SPECIFICATION FOR SUPPLY OF MATERIAL & CONSTRN/AGUMENTATION OF HT/LT LINES, SUBSTATION
NEG-SPEC-01	TP CENTRAL ODISHA DISTRIBUTION LIMITED	Date of Issue: 05/08/2020

Minimum works cube strength at 28 days should be at least 420 Kg/cm<sup>2</sup>. The concrete strength at transfer should be at least 210 Kg/cm<sup>2</sup>.

The mix should contain at least 380 Kg of cement per cubic meter of concrete.

The mix should contain as low water content as is consistent with adequate workability. It becomes necessary to add water to increase the workability the cement content also should be raised in such a way that the original value of water cement ratio is maintained.

### **(iii) Design Requirements**

The poles shall be designed for the following requirements:

The poles shall be planted directly in the ground with a planting depth as per IS: 1678. Wherever, planting depth is required to be increased beyond the specified limits or alternative arrangements are required to be made on account of ground conditions e.g. water logging etc., the same shall be in the scope of the bidder at no extra cost to TPCODL Utility. The bidder shall furnish necessary design calculations/details of alternative arrangements in this regard.

The working load on the poles should correspond to those that are likely to come on the pole during their service life. The factor of safety for all poles 9.0Mts. Shall not be less than 2.0 and for 8.0 M poles, the factor of safety shall not be less than 2.5. The average permanent load shall be 40% of the working load. The F.O.S. against first load shall be 1.0. At average permanent load, permissible tensile stress in concrete shall be 30 kg/cm<sup>2</sup>. At the design value of first crack load, the modulus of rupture shall not exceed 53.0kg/cm<sup>2</sup> for M-40. The ultimate moment capacity in the longitudinal direction should be at least one fourth of that in the transverse direction. The maximum compressive stress in concrete at the time of transfer of pre-stress should not exceed 0.8 times the cube strength.

The concrete strength at transfer shall not be less than half, the 28 days strength ensured in the design, i.e. 420x0.5=210kg/cm<sup>2</sup>. For model check calculations on the design of poles, referred to in the annexure, a reference may be made to the REC "Manual on Manufacturing of solid PCC poles, Part-I-Design Aspects.

### **(iv) Dimensions and Reinforcements**

The cross-sectional dimensions and the details of pre-stressing wires should conform to the particulars given in the enclosed drawing. The provisions of holes for fixing cross-arms and other fixtures should conform to the REC specification No.15/1979.

No.	Description	Prepared By & Date	Checked By & Date	Approved for Issue By & Date
		Anil Sah	Niranjan Khuntia	Pourush Garg
		05/08/2020	05/08/2020	05/08/2020

TP Central Odisha Distribution Limited		SPECIFICATION FOR SUPPLY OF MATERIAL & CONSTRN/AGUMENTATION OF HT/LT LINES, SUBSTATION
NEG-SPEC-01	TP CENTRAL ODISHA DISTRIBUTION LIMITED	Date of Issue: 05/08/2020

All pre-stressing wires and reinforcements shall be accurately fixed as shown in drawings and maintained in position during manufacture. The un-tensioned reinforcement as indicated in the drawings should be held in position by the use of stirrups which should go round all the wires.

All wires shall be accurately stretched with uniform pre-stressed in each wire. Each wire or group of wires shall be anchored positively during casing. Care should be taken to see that the anchorages do not yield before the concrete attains the necessary strength.

**V)Cover**

The cover of concrete measured from the outside of pre-stressing tendon shall be normally 20 mm.

**VI)Welding and Lapping of Steel**

The high tensile steel wire shall be continuous over the entire length of the tendon. Welding shall not be allowed in any case. However, joining or coupling may be permitted provided the strength of the joint or coupling is not less than the strength of each individual wire.

**VII)Compacting**

Concrete shall be compacted by spinning, vibrating, shocking or other suitable mechanical means. Hand compacting shall not be permitted.

**VIII)Curing**

The concrete shall be covered with a layer of sacking, canvass, Hessian or similar absorbent material and kept constantly wet up to the time when the strength of concrete is at least equal to the minimum strength of concrete at transfer of pre-stress. Thereafter, the pole may be removed from the mould and watered at intervals to prevent surface cracking of the unit the interval should depend on the atmospheric humidity and temperature. The pre-stressing wires shall be de-tensioned only after the concrete has attained the specified strength at transfer (i.e. 200 or 210 kg/cm<sup>2</sup> as applicable).The cubes cast for the purpose of determining the strength at transfer should be cured, as far as possible, under condition similar to those under which the poles are cured. The transfer stage shall be determined based on the daily tests carried out on concrete cubes till the specified strength indicated above is reached. Thereafter the test on concrete shall be carried out as detailed in IS: 1343(code of practice for pre-stressed concrete). The manufacture shall supply, when required by the TPCODL Utility or his representative, result of compressive test conducted in accordance with IS: 456 (Code of practice for plain and reinforced concrete) on concrete cubes made from the concrete used for the poles. If the manufacture so desired, the manufacture shall supply cubes for test purpose and such cubes shall be tested in accordance with IS: 456 (Code of practice for plain and reinforced concrete).

No.	Description	Prepared By & Date	Checked By & Date	Approved for Issue By & Date
		Anil Sah	Niranjan Khuntia	Pourush Garg
		05/08/2020	05/08/2020	05/08/2020



TP Central Odisha Distribution Limited		<b>SPECIFICATION FOR SUPPLY OF MATERIAL &amp; CONSTRN/AGUMENTATION OF HT/LT LINES, SUBSTATION</b>
NEG-SPEC-01	TP CENTRAL ODISHA DISTRIBUTION LIMITED	Date of Issue: 05/08/2020

**(IX) Lifting Eye-Hooks or Holes**

Separate eye-hooks or hoes shall be provided for handling the transport, one each at a distance of 0.15 times the overall length, from either end of the pole. Eye-hooks, if provided, should be properly anchored and should be on the face that has the shorter dimension of the cross-section. Holes, if provided for lifting purpose, should be perpendicular to the broad face of the pole.

**(X) Holes for Cross Arms etc**

Sufficient number of holes shall be provided in the poles for attachment of cross arms and other equipments.

**(XI) Stacking & Transportation**

Stacking should be done in such a manner that the broad side of the pole is vertical. Each tier in the stack should be supported on timber sleeper located as 0.15 times the overall length, measured from the end. The timber supported in the stack should be aligned in vertical line.

**(XII) Earthing**

- ✓ Earthing shall be provided by having length of 8 / 6 SWG GI wire embedded in Concrete during manufacture and the ends of the wires left projecting from the pole to a length of 100mm at 250 mm from top and 1000 mm below ground level.
- ✓ Earth wire shall not be allowed to come in contact with the pre-stressing wires

**GUARANTEED TECHNICAL PARTICULARS of 9 Mtr. 300 KG PSC Pole**

(To be submitted along with offer in line with the Standard Design)

SI No.	Description	Unit	Req. Specification	Bidders Offer
1	Name of the Manufacturer & Address		To be specified	
2	Type of pole		Pre- Stress Concrete	
3	Factor of Safety		2.5	
4	Overall Length of Pole Meters	Mtr.	9	
5	Working Load Kg	Kg	300	

No.	Description	Prepared By & Date	Checked By & Date	Approved for Issue By & Date
		Anil Sah	Niranjan Khuntia	Pourush Garg
		05/08/2020	05/08/2020	05/08/2020



TP Central Odisha Distribution Limited		SPECIFICATION FOR SUPPLY OF MATERIAL & CONSTRN/AGUMENTATION OF HT/LT LINES, SUBSTATION
NEG-SPEC-01	TP CENTRAL ODISHA DISTRIBUTION LIMITED	Date of Issue: 05/08/2020

6	Point of application of load		600 mm below from top	
7	Depth of plantation	mm	1500	
8	<b>Overall Dimensions</b>			
i)	Bottom Depth	mm	355	
ii)	Top Depth	mm	185	
iii)	Breadth	mm	100	
9	<b>Reinforcement Detail:</b>			
i)	Diameter of Pre-stressing wire	mm	4	
ii)	No. of Tensioned wires	Nos.	16	
iii)	No. of Un-tensioned wire	Nos.	--	
iv)	Length of each Pre-stressing wire	Mtr.	9	
v)	Ultimate Tensile Strength	Kg/cm <sup>2</sup>	17500	
vi)	Steel Quantity	Kg/pole	14.20	
10	<b>Concrete Detail</b>			
i)	Cement Type		Ordinary Portland Cement	
ii)	Concrete mix strength	Kg/cm <sup>2</sup>	a) 210 Kg/cm <sup>2</sup> at time of transfer of prestress (min)	
		Kg/cm <sup>2</sup>	b) 420 Kg/cm <sup>2</sup> at age of 28 days (min)	
iii)	Concrete Quantity	Cubic meter/pole	0.243 m <sup>3</sup>	
iv)	Concrete covering to wires	mm	20	
11	GI earthing wire	SWG	6	
12	Weight of PSC Pole	Kg	607	
13	Standard confirming to:			
	Pole		IS: 1678 /2000	
	Cement		IS: 8041	
	Aggregates		IS: 383/1970	

No.	Description	Prepared By & Date	Checked By & Date	Approved for Issue By & Date
		Anil Sah	Niranjana Khuntia	Pourush Garg
		05/08/2020	05/08/2020	05/08/2020

TP Central Odisha Distribution Limited	 TP CENTRAL ODISHA DISTRIBUTION LIMITED	SPECIFICATION FOR SUPPLY OF MATERIAL & CONSTRN/AGUMENTATION OF HT/LT LINES, SUBSTATION
NEG-SPEC-01		Date of Issue: 05/08/2020

	Pre-stressing wire	IS: 6003/1983	
	Concrete Mix	IS: 456/2000	
14	Tolerances Dimensions	a)±15 mm on overall length of pole	
		b) ±5 mm on sectional dimension	
		c)0.5% on the uprightness of pole	



No.	Description	Prepared By & Date	Checked By & Date	Approved for Issue By & Date
		Anil Sah	Niranjan Khuntia	Pourush Garg
		05/08/2020	05/08/2020	05/08/2020

TP Central Odisha Distribution Limited		SPECIFICATION FOR SUPPLY OF MATERIAL & CONSTRN/AGUMENTATION OF HT/LT LINES, SUBSTATION
NEG-SPEC-01	TP CENTRAL ODISHA DISTRIBUTION LIMITED	Date of Issue: 05/08/2020

✓ All the poles shall be provided with a RCC block base having dimensions as mentioned at 5.0.2 ( C) as per the site requirement to be decided by Engineer in Charge. The decision of Engineer in Charge will be Final.

✓ The poles shall then be lifted to the pit with the help of wooden supports. The pole shall then be kept in the vertical position with the help of 25 mm (min.) manila ropes, which will act as the temporary anchor. The verticality of the pole shall be checked by spirit level in both

✓ longitudinal & transverse directions. The temporary anchor shall be removed only when poles set properly in the pit for foundation concreting & backfilling with proper compacting the soil.

✓ Concreting of foundation up to a minimum height of 1/6 th of the height of the pole from the bottom of the pit with a circular cross-section of radius 0.25 mtrs. (volume of 0.3 cu.mtr. per pole) in the ratio of 1:3:6 shall be done at the following locations: The depth has to be increased to 2mtr or as required at site condition if poles more than 11 Mts. are to be used.

- At all the tapping points and dead end poles.
- At all the points as per REC construction dwg. No. A-10 (for the diversion angle of 10-60 degree) or better there of as per the instruction of Engineer in charge. The decision of Engineer in charge will be final.

Rev No.	Description	Prepared By & Date	Checked By & Date	Approved for Issue By & Date
R0		Anil Sah	Niranjan Khuntia	Pourush Garg
		05/08/2020	05/08/2020	05/08/2020

TP Central Odisha Distribution Limited		<b>SPECIFICATION FOR SUPPLY OF MATERIAL &amp; CONSTRN/AGUMENTATION OF HT/LT LINES, SUBSTATION</b>
NEG-SPEC-01	TP CENTRAL ODISHA DISTRIBUTION LIMITED	Date of Issue: 05/08/2020

## **10. CROSS ARM**

“V” and straight Cross Arms should be made by using G I 100x50 ISMCmm for 33 KV & 75 x 40 ISMC for 11 KV line.

### **11 KV “V” CROSS ARM, BACK CLAMP FOR “V” CROSS ARM & POLE TOP BRACKET (F CLAMP)**

#### **TECHNICAL SPECIFICATIONS**

##### **10.0.01 Qualifying Criteria :-**

The prospective bidder may source the above items from manufacturers /suppliers full filling the technical specification.

- a) Hot Dip Galvanised Cross arms and Pole Top Brackets for both 33KV & 11KV construction at intermediate and light angle pole shall be fabricated from grade 43A mild steel of channel section and for heavy angle poles, end poles and section poles fabricated from grade 43A mild steel of angle section. The grades of structural steel shall conform to IS – 226: 1975.
- b) The Back Clamp for both 33KV & 11 KV ‘V’ cross arm shall be made out of 50 x 8 GI Flat and shall be suitably designed to fit 150x150 mm RS Joist pole.
- c) The Pole Top Bracket (F Clamp) shall be made out of 100x50 mm MS Channel (GI) for 33 KV & 75x40 MS channel (GI) suitably designed to fit 150 x150xmm RS Joist pole.

Except where otherwise indicated all dimensions are subject to the following tolerances: dimensions up to and including 50mm:+1mm: and dimensions greater than 50mm: +2%

All steel members and other parts of fabricated material as delivered shall be free of warps, local deformation, unauthorized splices, or unauthorized bends. Bending of flat strap shall be carried out cold. Straightening shall be carried out by pressure and not by hammering.

Rev No.	Description	Prepared By & Date	Checked By & Date	Approved for Issue By & Date
R0		Anil Sah	Niranjan Khuntia	Pourush Garg
		05/08/2020	05/08/2020	05/08/2020

TP Central Odisha Distribution Limited	 TP CENTRAL ODISHA DISTRIBUTION LIMITED	SPECIFICATION FOR SUPPLY OF MATERIAL & CONSTRN/AGUMENTATION OF HT/LT LINES, SUBSTATION
NEG-SPEC-01		Date of Issue: 05/08/2020

Straightness is of particular importance if the alignment of bolt holes along a member is referred to its edges.

Holes and other provisions for field assembly shall be properly marked and cross referenced. Where required, either by notations on the drawing or by the necessity of proper identification and fittings for field assembly, the connection shall be match marked. A tolerance of not more than 1mm shall be permitted in the distance between the center lines of bolt holes.

The holes may be either drilled or punched and, unless otherwise stated, shall be not more than 2mm greater in diameter than the bolts. When assembling the components force may be used to bring the bolt holes together (provided neither members nor holes are thereby distorted) but all

force must be removed before the bolt is inserted. Otherwise strain shall be deemed to be present and the structure may be rejected even though it may be, in all other respects, in conformity with the specification.

The back of the inner angle irons of lap joints shall be chamfered and the ends of the members cut where necessary and such other measures taken as will ensure that all members can be bolted together without strain or distortion. In particular, steps shall be taken to relieve stress in prevent the onset of embitterment during galvanizing

Shapes and plates shall be fabricated and assembled in the shop to the greatest extent practicable. Shearing flame cutting and chipping shall be done carefully, neatly and accurately. Holes shall be cut, drilled or punched at right angles to the surface and shall not be made or enlarged by burning. Holes shall be clean-cut without torn or ragged edges, and burrs resulting from drilling or reaming operations shall be removed with the proper tool.

Shapes and plates shall be fabricated to the tolerance that will permit field erection within tolerance, except as otherwise specified. All fabrication shall be carried out in a neat and workmanlike manner so as to facilitate cleaning, painting, galvanizing and inspection and to avoid areas in which water and other matter can lodge.

Rev No.	Description	Prepared By & Date	Checked By & Date	Approved for Issue By & Date
RO		Anil Sah	Niranjan Khuntia	Pourush Garg
		05/08/2020	05/08/2020	05/08/2020

TP Central Odisha Distribution Limited		<b>SPECIFICATION FOR SUPPLY OF MATERIAL &amp; CONSTR/AGUMENTATION OF HT/LT LINES, SUBSTATION</b>
NEG-SPEC-01	TP CENTRAL ODISHA DISTRIBUTION LIMITED	Date of Issue: 05/08/2020

Contact surfaces at all connections shall be free of loose scale, dirt, burrs, oil and other foreign materials that might prevent solid seating of the parts.

**10.0.2 Fabrication has to be made as per drg. of „V „X-arm, Back clamp & „F „clamp**

**GALVANISING**

All type of cross arms back clamps, F clamps & stay clamps shall be hot dip galvanized, are as following

All galvanizing shall be carried out by the hot dip process, in accordance with Specification IS

2629. However, high tensile steel nuts, bolts and spring washer shall be electro galvanized to Service Condition 4. The zinc coating (610 gms per sq.mt) shall be smooth, continuous and uniform. It shall be free from acid spot and shall not scale, blister or be removable by handling or packing.

There shall be no impurities in the zinc or additives to the galvanic bath which could have a detrimental effect on the durability of the zinc coating.

Before picking, all welding, drilling, cutting, grinding and other finishing operations must be completed and all grease, paints, varnish, oil, welding slag and other foreign matter completely removed.

All protuberances which would affect the life of galvanizing shall also be removed.

**The weight of zinc deposited shall be in accordance with that stated in Standard IS 2629 and shall not less than 0.61kg/m<sup>2</sup> with a minimum thickness of 86 microns for items of**

**thickness more than 5mm, 0.46kg/m<sup>2</sup> (64 microns) for items of thickness between 2mm and 5mm and 0.33kg/m<sup>2</sup> (47 microns) for items less than 2mm thick.**

Parts shall not be galvanized if their shapes are such that the pickling solutions cannot be removed with certainty or if galvanizing would be unsatisfactory or if their mechanical strength would be reduced. Surfaces in contact with oil shall not be galvanized unless they are subsequently coated with an oil resistant varnish or paint.

Rev No.	Description	Prepared By & Date	Checked By & Date	Approved for Issue By & Date
R0		Anil Sah	Niranjan Khuntia	Pourush Garg
		05/08/2020	05/08/2020	05/08/2020

TP Central Odisha Distribution Limited		SPECIFICATION FOR SUPPLY OF MATERIAL & CONSTRN/AGUMENTATION OF HT/LT LINES, SUBSTATION
NEG-SPEC-01	TP CENTRAL ODISHA DISTRIBUTION LIMITED	Date of Issue: 05/08/2020

In the event of damage to the galvanizing the method used for repair shall be subject to the approval of the Engineer in Charge or that of his representative.

**In no case the repair of galvanisation on site will be permitted.**

The threads of all galvanized bolts and screwed rods shall be cleared of spelter by spinning or brushing. A die shall not be used for cleaning the threads unless specifically approved by the Engineer in Charge. All nuts shall be galvanized. The threads of nuts shall be cleaned with a tap and the threads oiled.

Partial immersion of the work shall not be permitted and the galvanizing tank must therefore be sufficiently large to permit galvanizing to be carried out by one immersion.

After galvanizing no drilling or welding shall be performed on the galvanized parts of the equipment excepting that nuts may be threaded after galvanizing. To avoid the formation of white rust galvanized materials shall be stacked during transport and stored in such a manner as to permit adequate ventilation. Sodium dichromate treatment shall be provided to avoid formation of white rust after hot dip galvanization.

The galvanized steel shall be subjected to test as per IS-2633.

**10.0.3 11 KV V Cross Arm (GI) :**

The Cross arm is to be made out of ISMC 75x40 with 50mmx6mm flat packing on top & bottom flange of the channel where the insulator pin is to be mounted conforming to REC construction standard & drawing . Galvanized the V cross arm as per IS-2633/1972.(Latest Amendment) , IS :2629/1985 (1<sup>st</sup>. Revision).

Rev No.	Description	Prepared By & Date	Checked By & Date	Approved for Issue By & Date
RO		Anil Sah	Niranjan Khuntia	Pourush Garg
		05/08/2020	05/08/2020	05/08/2020



TP Central Odisha Distribution Limited		SPECIFICATION FOR SUPPLY OF MATERIAL & CONSTRN/AGUMENTATION OF HT/LT LINES, SUBSTATION
NEG-SPEC-01	TP CENTRAL ODISHA DISTRIBUTION LIMITED	Date of Issue: 05/08/2020

**Guaranteed Technical Particulars of 11KV 'V' Cross Arm**

Sl. No.	Description	Specified	Bidders Offer
1	Type of Cross Arm	ISMC 75x40	
2	Channel Weight	7.14 Kg/mtr	
3	Grade of Steel	FY 250	
4	Steel Standard	IS:2062-1992	
5	Fabrication Standard	IS:802 (part - 2) - 1978	
6	Dimension	(75x40x4.8)mm	
7	Size of M S Flat welded at both ends	50x8mm	
8	Steel Tensile Strength	1500kgf/cm <sup>2</sup>	
9	Working Load	200/300/350/400Kg	
10	Total Weight (with tolerance per meter + 4%)	11.2 Kg (approx.)	

**10.0.3 11 KV F Clamp/ Pole top Bracket (GI) :**

11 KV line pole top bracket made out of 65 mm long 100x50x6 mm M.S channel welded with 65x65x6 mm M.S Angle & hot dip galvanize as per IS-2633/1972.(Latest Amendment) , confirming to REC Construction Standard.M-4 & drawing .

Rev No.	Description	Prepared By & Date	Checked By & Date	Approved for Issue By & Date
R0		Anil Sah	Niranjan Khuntia	Pourush Garg
		05/08/2020	05/08/2020	05/08/2020



TP Central Odisha Distribution Limited		SPECIFICATION FOR SUPPLY OF MATERIAL & CONSTRN/AGUMENTATION OF HT/LT LINES, SUBSTATION
NEG-SPEC-01	TP CENTRAL ODISHA DISTRIBUTION LIMITED	Date of Issue: 05/08/2020

**GUARANTEED TECHNICAL PARTICULARS FOR 11KV POLE TOP BRACKET**

Sl.No.	Constructional Features	Specified	Bidders Offer
1.	Material used	65x65x6 mm MS Angle & 100x50x6 mm MS Channel	
2.	Overall height	380 mm	
3.	Flange Width (one welded &	65 mm	
4.	Spacing between two flanges	100mm	
5.	Spacing of 2 nos of 18 mm holes for fixing on pole top	100mm	
6.	C/L Distance of 2nos of 25mm holes on top flanges of the bracket	40mm from edge of the flange	
7.	Galvanization	Hot dip	
8.	ISS	2062 ,2633	
9.	Drawing	enclosed	

Rev No.	Description	Prepared By & Date	Checked By & Date	Approved for Issue By & Date
R0		Anil Sah	Niranjan Khuntia	Pourush Garg
		05/08/2020	05/08/2020	05/08/2020

TP Central Odisha Distribution Limited	 TP CENTRAL ODISHA DISTRIBUTION LIMITED	SPECIFICATION FOR SUPPLY OF MATERIAL & CONSTR/AGUMENTATION OF HT/LT LINES, SUBSTATION
NEG-SPEC-01		Date of Issue: 05/08/2020

#### 10.0.4 11KV POLE TOP BRACKETS (F CLAMP)

##### GURANTEED TECHNICAL PARTICULARS

2	Type of V Cross Arm		
2	Grade of steel		
3	Steel standard		
4	Fabrication Standard		
5	Dimensions	Mm	
6	Steel section utilized		
7	Steel tensile strength	N/cm <sup>2</sup>	
8	Working load	Kg	
9	Details of galvanizing method utilized and standard/specification conforming to?		
10	Weight of bracket	Kg	
11	Whether drawing has been submitted with the bid		

(To be

submitted along with offer)

#### 10.0.5 BACK CLAMP FOR "V" CROSS ARM

##### GURANTEED TECHNICAL PARTICULARS

(To be submitted along with offer)

Sl. No.	Description Unit	Unit	Bidder's offer	
			11 Kv	
1	Type of Clamp			
2	Grade of steel			
3	Steel standard			
4	Fabrication Standard			
5	Dimensions	Mm		
6	Steel section utilized			
7	Steel tensile strength	N/cm <sup>2</sup>		
8	Working load	Kg		
9	Details of galvanizing method utilized and standard/specification conforming to?			
10	Weight of back clamp	Kg		
11	Whether drawing has been submitted with the bid			

Rev No.	Description	Prepared By & Date	Checked By & Date	Approved for Issue By & Date
R0		Anil Sah	Niranjan Khuntia	Pourush Garg
		05/08/2020	05/08/2020	05/08/2020

TP Central Odisha Distribution Limited		<b>SPECIFICATION FOR SUPPLY OF MATERIAL &amp; CONSTRN/AGUMENTATION OF HT/LT LINES, SUBSTATION</b>
NEG-SPEC-01	TP CENTRAL ODISHA DISTRIBUTION LIMITED	Date of Issue: 05/08/2020

### **Fixing of Cross Arms**

After the erection of supports and providing guys, the cross-arms are to be mounted on the support with necessary clamps, bolts and nuts. The practice of fixing the cross arms before the pole erection should be followed.

### **GI Clamp for HT Stay set :**

HT stay clamp suitable for 150x150 mm Joist pole made out of 50x8 mm GI Flat, confirming to latest IS Specification and .

### **GI Clamp for LT Stay set :**

LT stay clamp suitable for PSC poles made out of 50x6 mm GI Flat, confirming to latest IS Specification.

## **8.0 INSTALLATION OF LINE MATERIALS**

**8.0.1 Insulator and Bindings** - These materials are to be procured from the approved vendors only subsequent to the design approval. separate specification attached for insulator with polymer type

### **8.0.2 Insulator hoisting**

- a) Insulators shall be completely cleaned with soft and clean cloth.
- b) It shall be verified that there is no crack or any other damage to insulators.

**The pins for insulators** shall be fixed in the holes provided in the cross-arms and the pole top brackets. The insulators shall be mounted in their places over the pins and tightened. In the case of strain or angle supports, where strain fittings are provided for this purpose, one strap of the strain fittings is placed over the cross-arm before placing the bolt in the hole of cross-arms. The nut of the straps shall be so tightened that the strap can move freely in horizontal direction.

Rev No.	Description	Prepared By & Date	Checked By & Date	Approved for Issue By & Date
R0		Anil Sah	Niranjan Khuntia	Pourush Garg
		05/08/2020	05/08/2020	05/08/2020

TP Central Odisha Distribution Limited	 TP CENTRAL ODISHA DISTRIBUTION LIMITED	SPECIFICATION FOR SUPPLY OF MATERIAL & CONSTRN/AGUMENTATION OF HT/LT LINES, SUBSTATION
NEG-SPEC-01		Date of Issue: 05/08/2020

All materials, which are to be supplied by the contractor should be procured from the approved Manufacture/suppliers only. Procurement from any suppliers will not be permitted. All the related drawings of materials have to be approved by department. All the materials has to be tested in presence of authorized representative of department as well as officers of third party engaged by Government if any also.

**SPECIFICATION FOR 11KV POLYMER PIN INSULATOR**

- The Composite insulators will be used on lines on which the conductor will be ACSR of size up to 200 Sq.mm. The insulators should withstand the conductor tension, the reversible wind load as well as the high frequency vibrations due to wind.
- Insulator shall be suitable for 3 Phase, 50 Hz effectively earthed 11KV Overhead Lines Grounded distribution systems in a moderately/heavily polluted atmosphere.
- Bidder must be an indigenous manufacturer and supplier of composite insulators of rating 11KV or above or must have developed proven in house technology and manufacturing process for composite insulators of above rating. The Bidder shall furnish necessary evidence in support of the above along with the bid, which can be in the form of certification from the utilities concerned, or any other documents to the satisfaction of the owner.
- Insulator shall be suitable for the long Rod Type.
- Insulators shall have sheds with good self-cleaning properties. Insulator shed profile, spacing, projection etc. and selection in respect of polluted conditions shall be generally in accordance with the commendation of IEC- 60815/ IS: 13134.
- The tolerances on all dimensions e.g. diameter, length and creepage distance shall be allowed as follows in line with-IEC 61109:

$$\pm (0.04d + 1.5) \text{ mm when } d \leq 300 \text{ mm}$$

$$\pm (0.025d+6) \text{ mm when } d > 300 \text{ mm}$$

Where, d being the dimensions in millimeters for diameter, length or creepage distance as the case may be. However, no negative tolerance shall be applicable to creepage distance.

- The composite insulators including the end fitting connection shall be standard

Rev No.	Description	Prepared By & Date	Checked By & Date	Approved for Issue By & Date
RO		Anil Sah	Niranjan Khuntia	Pourush Garg
		05/08/2020	05/08/2020	05/08/2020

TP Central Odisha Distribution Limited		<b>SPECIFICATION FOR SUPPLY OF MATERIAL &amp; CONSTRN/AGUMENTATION OF HT/LT LINES, SUBSTATION</b>
<b>NEG-SPEC-01</b>	TP CENTRAL ODISHA DISTRIBUTION LIMITED	<b>Date of Issue: 05/08/2020</b>

design suitable for use with the hardware fittings of any make conforming to relevant IEC/IS standards.

- All surfaces shall be clean, smooth, without cuts, abrasions or projections. No part shall be subjected to excessive localized pressure. The insulator and metal parts shall be so designed and manufactured that it shall avoid local corona formation and not generate any radio interference beyond specified limit under the operating conditions.
- **Service condition** : The insulators to be supplied against this specification shall be suitable for satisfactory continuous operation under the following topical condition :
  - Max. ambient temperature : 50 °
  - Min. ambient temperature : 0 ° C
  - Relative humidity : 10 % to 100 %
  - Max. Anual Rainfall : 2000 mm
  - Max. Wind Pressure : 180 Kg/ sq. Meter

Climatic condition : Moderately hot and humid tropical climate, conducive to rust and fungus groth. Polution level is high. Some area with seashores having saline atmosphere.

**System Parameters:**

- a) Nominal system voltage : 11 KV
- b) Highest system voltage : 12 KV
- c) Power frequency : 50 Hz.
- d) Number of Phases : Three.
- e) System earthing: 11 KV Solidly earthed

**Standard** : The following Indian / International Standards with latest revisions and amendments shall be referred while accessing conformity of insulators with this specification.

Sl. No.	Indian Standar	Title	Internation al
1.		Definition, test methods and acceptance criteria for composite insulators for a.c. overhead lines above 1000V	IEC : 61109
2.	IS : 731	Porcelain insulators for overhead power lines with a nominal voltage greater than 1000V	IEC : 60383
3.	IS : 2071	Methods of High Voltage Testing	IEC : 60060-1

Rev No.	Description	Prepared By & Date	Checked By & Date	Approved for Issue By & Date
R0		Anil Sah	Niranjan Khuntia	Pourush Garg
		05/08/2020	05/08/2020	05/08/2020

TP Central Odisha Distribution Limited		<b>SPECIFICATION FOR SUPPLY OF MATERIAL &amp; CONSTRN/AGUMENTATION OF HT/LT LINES, SUBSTATION</b>
<b>NEG-SPEC-01</b>	TP CENTRAL ODISHA DISTRIBUTION LIMITED	<b>Date of Issue: 05/08/2020</b>

4.	IS : 2486	Specification for insulator fittings for overhead power lines with a nominal voltage greater than 1000V General Requirements and Tests Dimensional Requirements Locking Devices	IEC : 60120 IEC : 60372
5.		Thermal Mechanical Performance test and mechanical performance test on string insulator units	IEC : 60575
6.	IS : 13134	Guide for the selection of insulators in respect of polluted conditions	IEC : 60815
7.		Characteristics of string insulator units of the long rod type	IEC : 60433
8.		Hydrophobicity classification guide	STRI guide 1.92/1
9.		Radio interference characteristics of overhead power lines and high-voltage	CISPR:18-2 part2
10.	IS : 8263	Methods of RI Test of HV Insulators	IEC : 60437
11.		Standard for insulators – Composite- Distribution Dead-	ANSI C29 13- 2000
12.	IS : 4759	Hot dip zinc coatings on structural steel & other allied products	ISO : 1459 ISO : 1461
13.	IS : 2629	Recommended Practice for Hot, Dip Galvanization for iron	ISO-1461 (E)
14.	IS : 6745	Determination of weight of zinc coating on zinc coated iron and steel articles	ISO : 1460
15.	IS : 3203	Methods of testing of local thickness of electroplated coatings	ISO : 2178
16.	IS : 2633	Testing of Uniformity of coating of zinc coated articles	
17.		Standard specification for glass fiber strands	ASTMD 578-05
18.		Standard test method for compositional analysis by Thermo-	ASTM E 1131- 03
19.	IS : 4699	Specification for refined secondary zinc	

Rev No.	Description	Prepared By & Date	Checked By & Date	Approved for Issue By & Date
R0		Anil Sah	Niranjan Khuntia	Pourush Garg
		05/08/2020	05/08/2020	05/08/2020

TP Central Odisha Distribution Limited		SPECIFICATION FOR SUPPLY OF MATERIAL & CONSTRN/AGUMENTATION OF HT/LT LINES, SUBSTATION
NEG-SPEC-01	TP CENTRAL ODISHA DISTRIBUTION LIMITED	Date of Issue: 05/08/2020

**Technical Requirement:**

1. Composite Insulators shall be designed to meet the light quality, safety and reliability and are capable of withstanding a wide range of environmental conditions.

- (a) Core : The internal insulating part
- (b) Housing : The external insulating part.
- (c) Metal end fittings: For attaching to hardware to support conductor.

Metal end fittings shall be uniform and without sharp edges or corners and shall be free of cracks, flakes, silvers, slag, blow-holes shrinkages defects and localized porosity.

They shall be connected to the rod by means of a controlled compression technique. As the main duty of the end fittings is the transfer of mechanical loads to the core the fittings should be property attached to the core by a coaxial or hexagonal compression process and should not damage the individual fibers or crack the core.

The gap between fittings and sheath shall be sealed by flexible silicone elastometric compound or silicone alloy compound sealant, system of attached of end

**Core:** It shall be a glass-fiber reinforced epoxy resin rod of high strength (FRP rod).

Glass fibbers and resin shall be optimized in the FRP rod. Glass fibbers shall be Boron free electrically corrosion resistant (ECR) glass fibber or Boron free E-Glass and shall exhibit both high electrical integrity and high resistance to acid corrosion. The matrix of the FRP rod shall be Hydrolysis resistant. The FRP shall be manufactured through Pultrusion process. The FRP rod shall be void free.

**Housing (Sheath):**

The FRP rod shall be covered by a seamless sheath of a silicone elastometric compound or silicone alloy compound of a thickness of 3 mm minimum. It shall be one-piece housing using injection Moulding Principle to cover the core. The elastomer housing shall be designed to provide the necessary creepage distance and protection against environmental influences, external pollution and humidity. Housing shall conform to the requirement of IEC 61109/92-93 with latest amendments.

It shall be extruded or directly moulded on core and shall have chemical bonding with the FRP rod. The strength of the bond shall be greater than the tearing strength of the polymer. Sheath material in the bulk as well as in the sealing / bonding area shall be free from voids.

Rev No.	Description	Prepared By & Date	Checked By & Date	Approved for Issue By & Date
RO		Anil Sah	Niranjan Khuntia	Pourush Garg
		05/08/2020	05/08/2020	05/08/2020



TP Central Odisha Distribution Limited		SPECIFICATION FOR SUPPLY OF MATERIAL & CONSTR/AGUMENTATION OF HT/LT LINES, SUBSTATION
NEG-SPEC-01	TP CENTRAL ODISHA DISTRIBUTION LIMITED	Date of Issue: 05/08/2020

Manufacturer should furnish a description of its quality assurance programme including fabrication; testing and inspection for any material (i.e rubber) Components (i.e rod) or hardware (i.e. end filings). The manufacturer has had fabricated by others should also be included. Manufacturing methods and material composition documentation will be a part of Technical Bid to be submitted along with offer.

**WEATHERSHEDS:**

The composite polymer Weathersheds made of silicone elastometric compound or silicon alloy shall be firmly bonded to the sheath, vulcanized to the sheath or moulded as part of the sheath and shall be free from imperfections. The weathersheds should have silicon content of minimum 30% by weight. The strength of the weathershed to sheath interface shall be greater than the tearing strength of the polymer. The interface, if any, between sheds and sheath (housing) shall be free from voids.

**METAL END FITTINGS:**

End fittings transmit the mechanical load to the core. Hardware of respective specified mechanical load and shall be hot dip galvanized in Zinc coated with minimum 99.95 % purity of electrolytic high grade Zinc in accordance with IS 2629. The material used in fittings shall be corrosion resistant.

fitting to the rod shall provide superior sealing performance between housing, i.e. seamless sheath and metal connection. The sealing must be moisture proof.

The dimensions of end fittings of insulators shall be in accordance with the standard dimensions stated in IEC: 60120/IS:2486 Part-II/1989.

Nominal dimensions of the pin insulator shall be in accordance with the Specific Technical Particulars. No joints in pin will be allowed. Outer portion of Pin should be Zinc coated with minimum 99.95% purity of electrolytic high grade Zinc.

The finished surface shall be smooth and shall have a good performance. The surface shall not crack or get chipped due to ageing effect under normal and abnormal service conditions or while handling during transit or erection.

The design of the fittings and the insulators shall be such that there is no local corona formation or discharges likely to cause the interference to either should or vision transmission.

Bottom end metal fitting (Shank) of Pin Insulator should be as per IS: 2486. Length of thread on shank should be minimum 110 mm for 11 KV Pin and 130 mm for 33 KV Pin insulator. Shank diameter is 20 mm for 11 KV Pin Insulator & 24 mm for 33 KV Pin Insulator. Minimum Collar diameter should be 40 mm and its minimum thickness should be of

Rev No.	Description	Prepared By & Date	Checked By & Date	Approved for Issue By & Date
RO		Anil Sah	Niranjan Khuntia	Pourush Garg
		05/08/2020	05/08/2020	05/08/2020



TP Central Odisha Distribution Limited		SPECIFICATION FOR SUPPLY OF MATERIAL & CONSTRN/AGUMENTATION OF HT/LT LINES, SUBSTATION
NEG-SPEC-01	TP CENTRAL ODISHA DISTRIBUTION LIMITED	Date of Issue: 05/08/2020

5 mm. Two number nuts as per IS 1363 (P-III) and 4 mm thick Spring Washer shall be as per IS 3063 with latest amendments if any, Nuts and spring washer shall be hot dipgalvanized.

**Workmanship :**

a ) All the materials shall be of latest design and conform to the best engineering practices adopted in the high voltage filed. Bidders shall offer only such insulators as are guaranteed by them to be satisfactory and suitable for continued good service in power transmission lines.

b ) The design, manufacturing process and material control at various stages shall be such as to give maximum working load, highest mobility, best resistance to corrosion, good finish and elimination of sharp edges and corners.

c ) The design of the insulators shall be such that stresses due to expansion and contraction in any part of the insulator shall not lead to deterioration.

d ) The core shall be sound and free of cracks and voids that may adversely affect the insulators.

e ) Weather sheds shall be uniform in quality. They shall be clean, sound and smooth and shall be free from defects and excessive flashing at parting lines.

f ) End fittings shall be free from cracks, seams, shrinks, air holes and rough edges. End fittings should be effectively sealed to prevent moisture ingress. Effectiveness of sealing system must be supported by test documents. All surfaces of the metal parts shall be perfectly smooth without projecting points or irregularities, which may cause corona. All load bearing surfaces shall be smooth and uniform so as to distribute the loading stresses uniformly.

g ) All ferrous parts shall be hot dip galvanized to give a minimum average coating of zinc equivalent to 610 gm/sq.m. or 87µm thickness and shall be in accordance with the requirement of IS:4579. The zinc used for galvanizing shall be of purity 99.5% as per IS : 4699. The zinc coating shall be uniform, adherent, smooth, reasonably bright continuous and free from imperfections such as flux, ash rust stains, bulky white deposits and blisters. The galvanized metal parts shall be guaranteed to withstand at least four successive dips each lasting for one (1) minute duration under the standard preece test. The galvanizing shall be carried out only after any machining

**Drawing :**

The bidder shall furnish along with the bid the outline drawing of each insulator unit including a cross sectional view of the long rod insulator unit. The drawing shall include but not be limited to the following information :

- (a) Long rod diameter with manufacturing tolerances
- (b) Minimum Creepage distance with positive tolerance

Rev No.	Description	Prepared By & Date	Checked By & Date	Approved for Issue By & Date
RO		Anil Sah	Niranjan Khuntia	Pourush Garg
		05/08/2020	05/08/2020	05/08/2020

TP Central Odisha Distribution Limited		SPECIFICATION FOR SUPPLY OF MATERIAL & CONSTR/AGUMENTATION OF HT/LT LINES, SUBSTATION
NEG-SPEC-01	TP CENTRAL ODISHA DISTRIBUTION LIMITED	Date of Issue: 05/08/2020

- (c) Protected creepage distance
- (d) Eccentricity of the long rod unit
  - (i) Axial run out
  - (ii) Radial run out
- (e) Unit mechanical and electrical characteristics
- (f) Weight of composite long rod units
- (g) Identification mark
  - (g) Manufacturer's catalogue number

. **Marking:** Each insulator shall be legibly and indelibly marked (embossing/engraved) to show the following:

- a ) Name & Trade mark of the manufacturer
- b ) Month & Year of manufacturing
- c ) Voltage & Type
- d ) Minimum Failing Load ( in KN)

**Type Test:** The following Type Test shall have to be conducted on insulator unit, components, materials or complete strings;

- a ) Dry Positive & Negative Lightning Impulse voltage withstand test
- b ) Dry Positive & Negative Lightning Impulse Flashover voltage test
- c ) Dry & Wet Power Frequency Voltage withstand test
- d ) Dry & Wet Power Frequency Voltage Flashover test
- e ) Mechanical Failing Load test.
- f ) Radio Interference test
- g) Recovery of Hydrophobicity test
- h ) Dye Penetration Test.
- i ) Water Diffusion Test
- j ) Chemical composition test for Silicon content
- k ) Brittle facture resistance test.

**Routine Test :**

- a ) Identification of marking
- b) Visual inspection
- c ) Mechanical routine test

**Acceptance Test :** The following test will be carried out at manufacturers works during inspection of the offered insulators before delivery :

- a ) Visual examination

Rev No.	Description	Prepared By & Date	Checked By & Date	Approved for Issue By & Date
RO		Anil Sah	Niranjan Khuntia	Pourush Garg
		05/08/2020	05/08/2020	05/08/2020

TP Central Odisha Distribution Limited		<b>SPECIFICATION FOR SUPPLY OF MATERIAL &amp; CONSTRN/AGUMENTATION OF HT/LT LINES, SUBSTATION</b>
NEG-SPEC-01	TP CENTRAL ODISHA DISTRIBUTION LIMITED	Date of Issue: 05/08/2020

- b ) Verification of dimension
- c ) Galvanizing test
- d ) Mechanical performance test
- e ) Mechanical Failing Load test

**MANDATORY GENERAL TECHNICAL PARTICULARS FOR 11 KV PIN INSULATOR**

	11 KV Pin	To be fillrd by Bidder
Type of insulator	Polymeric composite Pin Insulator	
Reference Standard	IEC 61109	
Material of FRP Rod	Borron free ECR	
Material of sheds	Silicon Rubber	
Material of Top End Fittings	SGCI /MCI/FORGED STEEL	
Material of Bottom End Fittings	FORGED STEEL	
Material of sealing compound	RTV Silicon	
Colour of sheds	Grey	
Rated voltage	11 KV	
Highest voltage	12 KV	
Dry Power Frequency Withstand voltage	60 KV	
Wet Power Frequency Withstand voltage	35 KV	
Dry Power Frequency Flashover Voltage	75 KV	
Wet Power Frequency Flashover Voltage	45 KV	
Dry Lightning Impulse withstand voltage	Positive : 75 KV Negative : 80 KV	

Rev No.	Description	Prepared By & Date	Checked By & Date	Approved for Issue By & Date
R0		Anil Sah	Niranjan Khuntia	Pourush Garg
		05/08/2020	05/08/2020	05/08/2020

<b>TP Central Odisha Distribution Limited</b>	<b>TPCODL</b>	<b>SPECIFICATION FOR SUPPLY OF MATERIAL &amp; CONSTRN/AGUMENTATION OF HT/LT LINES, SUBSTATION</b>
<b>NEG-SPEC-01</b>	TP CENTRAL ODISHA DISTRIBUTION LIMITED	<b>Date of Issue: 05/08/2020</b>

Dry Lightning Impulse Flashover voltage	Positive : 95 KV Negative : 100 KV	
RIV at 1 MHz when energised at 10 KV / 30 KV (rms) under dry condition	< 50 microvolt	
Creepage distance ( min )	320 mm	
Min Failing load	5 KN	
Dia of FRP Rod	20 mm	
Length of FRP Rod (min)	165 mm	
Dia of weather sheds	100 mm	
Thickness of housing	3 mm	
Dry arc distance	150 mm	
Method of fixing sheds to	Injection moulding	
Visible Discharge Voltage (PF)	9 KV	
No of weather sheds (min)	Three	
Type of sheds	Aerodynamic	
Dia of bottom end fitting	20 mm	
Thread length of bottom end	110 mm (Min)	
Type of packing	Wooden / Corrugated box	
No of insulator in each pack	Thirty	
Guarantee	12 months from commissioning or 18 months from the date of last despatch.	

### **Specification for Polymer Disc Insulator**

Rev No.	Description	Prepared By & Date	Checked By & Date	Approved for Issue By & Date
R0		Anil Sah	Niranjan Khuntia	Pourush Garg
		05/08/2020	05/08/2020	05/08/2020

TP Central Odisha Distribution Limited		SPECIFICATION FOR SUPPLY OF MATERIAL & CONSTRN/AGUMENTATION OF HT/LT LINES, SUBSTATION
NEG-SPEC-01	TP CENTRAL ODISHA DISTRIBUTION LIMITED	Date of Issue: 05/08/2020

1 . The Composite insulators will be used on lines on which the conductor will be ACSR of size up to 125 Sq.mm.The insulators should withstand the conductor tension, the reversible wind load as well as the high frequency vibrations due to wind.

2 . Insulator shall be suitable for 3 Phase, 50 Hz effectively earthed 11KV Overhead Lines and 33 KV Impedance distribution system in a moderately/heavily polluted atmosphere.

3 . Bidder must be an indigenous manufacturer and supplier of composite insulators of rating 11KV or above or must have developed proven in house technology and manufacturing process for composite insulators of above rating. The Bidder shall furnish necessary evidence in support of the above along with the bid, which can be in the form of certification from the utilities concerned, or any other documents to the satisfaction of the owner.

4 . Insulators shall be suitable for both Suspension & Strain type of load and shall be of tongue & clevis type.

5 . Insulator shall be suitable for the long Rod Type. The diameter of Composite Insulator shall be as per technical specification.

6 . Insulators shall have sheds with good self-cleaning properties. Insulator shed profile, spacing, projection etc. and selection in respect of polluted conditions shall be generally in accordance with the commendation of IEC- 60815/ IS: 13134.

7 . The tolerances on all dimensions e.g. diameter, length and creepage distance shall be allowed as follows in line with-IEC 61109:

$$\pm (0.04d + 1.5) \text{ mm when } d \leq 300 \text{ mm}$$

$$\pm (0.025d+6) \text{ mm when } d > 300 \text{ mm}$$

Where, d being the dimensions in millimeters for diameter, length or creepage distance as the case may be. However, no negative tolerance shall be applicable to creepage distance.

8 . The composite insulators including the end fitting connection shall be standard design suitable for use with the hardware fittings of any make conforming to relevant IEC/IS standards.

9. All surfaces shall be clean, smooth, without cuts, abrasions or projections. No part shall be subjected to excessive localized pressure. The insulator and metal parts shall be so

Rev No.	Description	Prepared By & Date	Checked By & Date	Approved for Issue By & Date
RO		Anil Sah	Niranjan Khuntia	Pourush Garg
		05/08/2020	05/08/2020	05/08/2020

TP Central Odisha Distribution Limited		<b>SPECIFICATION FOR SUPPLY OF MATERIAL &amp; CONSTRN/AGUMENTATION OF HT/LT LINES, SUBSTATION</b>
NEG-SPEC-01	TP CENTRAL ODISHA DISTRIBUTION LIMITED	Date of Issue: 05/08/2020

designed and manufactured that it shall avoid local corona formation and not generate any radio interference beyond specified limit under the operating conditions.

10 . Inter- changeability: The composite insulator together with the tongue & clevis fittings shall be of standard design suitable for use with the hardware of any other indigenous make confirming to relevant standards referred herewith.

➤ **Service condition** : The insulators to be supplied against this specification shall be suitable for satisfactory continuous operation under the following topical condition :

- Max. ambient temperature : 50 °
- Min. ambient temperature : 0 ° C
- Relative humidity : 10 % to 100 %
- Max. Anual Rainfall : 2000 mm
- Max. Wind Pressure : 180 Kg/ sq. Meter

Climatic condition : Moderately hot and humid tropical climate, conducive to rust and fungus groth. Polution level is high. Some area with seashores having saline atmosphere

**System Parameters:**

- a ) Nominal system voltage : 11 KV
- b ) Highest system voltage : 12 KV
- c ) Power frequency : 50 Hz.
- d ) Number of Phases : Three.
- e ) System earthing: 11 KV Solidly earthed

**Standard** : The following Indian / International Standards with latest revisions and amendments shall be referred while accessing conformity of insulators with this specification.

Sl. No.	Indian Standard	Title	Internationa l Standard
1.		Definition, test methods and acceptance criteria for composite insulators for a.c. overhead lines above 1000V	IEC : 61109
2.	IS : 731	Porcelain insulators for overhead power lines with a nominal voltage greater than 1000V	IEC : 60383

Rev No.	Description	Prepared By & Date	Checked By & Date	Approved for Issue By & Date
R0		Anil Sah	Niranjan Khuntia	Pourush Garg
		05/08/2020	05/08/2020	05/08/2020



<b>TP Central Odisha Distribution Limited</b>		<b>SPECIFICATION FOR SUPPLY OF MATERIAL &amp; CONSTRN/AGUMENTATION OF HT/LT LINES, SUBSTATION</b>
<b>NEG-SPEC-01</b>	<b>TP CENTRAL ODISHA DISTRIBUTION LIMITED</b>	<b>Date of Issue: 05/08/2020</b>

3.	IS : 2071	Methods of High Voltage Testing	IEC : 60060-1
4.	IS : 2486	Specification for insulator fittings for overhead power lines with a nominal voltage greater than 1000V General Requirements and Tests Dimensional Requirements Locking Devices	IEC : 60120 IEC : 60372
5.		Thermal Mechanical Performance test and mechanical performance test on string insulator units	IEC : 60575
6.	IS : 13134	Guide for the selection of insulators in respect of polluted conditions	IEC : 60815
7.		Characteristics of string insulator units of the long rod type	IEC : 60433
8.		Hydrophobicity classification guide	STRI guide 1.92/1
9.		Radio interference characteristics of overhead power lines and high-voltage equipment	CISPR:18-2 part
10.	IS : 8263	Methods of RI Test of HV Insulators	IEC : 60437
11.		Standard for insulators – Composite-Distribution Dead-end type	ANSI C29 13-2000
12.	IS : 4759	Hot dip zinc coatings on structural steel & other allied products	ISO : 1459 ISO : 1461
13.	IS : 2629	Recommended Practice for Hot, Dip Galvanisation for iron and steel	ISO-1461 (E)
14.	IS : 6745	Determination of weight of zinc coating on zinc coated iron and steel articles	ISO : 1460
15.	IS : 3203	Methods of testing of local thickness of electroplated coatings	ISO : 2178
16.	IS : 2633	Testing of Uniformity of coating of zinc coated articles	
17.		Standard specification for glass fiber strands	ASTMD 578-05

**Technical Requirement :**

1 . Composite Insulators shall be designed to meet the light quality, safety and reliability and are capable of withstanding a wide range of environmental conditions.

Core : The internal insulating part

Rev No.	Description	Prepared By & Date	Checked By & Date	Approved for Issue By & Date
RO		Anil Sah	Niranjan Khuntia	Pourush Garg
		05/08/2020	05/08/2020	05/08/2020

TP Central Odisha Distribution Limited	 TP CENTRAL ODISHA DISTRIBUTION LIMITED	SPECIFICATION FOR SUPPLY OF MATERIAL & CONSTRN/AGUMENTATION OF HT/LT LINES, SUBSTATION
NEG-SPEC-01		Date of Issue: 05/08/2020

Housing : The external insulating part.

Metal and fittings : For attaching to hardware to support conductor.

**Core :** It shall be a glass-fiber reinforced epoxy resin rod of high strength (FRP rod). Glass fibers and resin shall be optimized in the FRP rod. Glass fibers shall be Boron free electrically corrosion resistant (ECR) glass fiber or Boron free E-Glass and shall exhibit both high electrical integrity and high resistance to acid corrosion. The matrix of the FRP rod shall be Hydrolysis resistant. The FRP shall be manufactured through Pultrusion process. The FRP rod shall be void free.

Housing (Sheath) :

The FRP rod shall be covered by a seamless sheath of a silicone elastomeric compound or silicone alloy compound of a thickness of 3 mm minimum. It shall be one-piece housing using injection Moulding Principle to cover the core. The elastomer housing shall be designed to provide the necessary creepage distance and protection against environmental influences, external pollution and humidity. Housing shall conform to the requirement of IEC 61109/92-93 with latest amendments.

It shall be extruded or directly moulded on core and shall have chemical bonding with the FRP rod. The strength of the bond shall be greater than the tearing strength of the polymer. Sheath material in the bulk as well as in the sealing / bonding area shall be free from voids.

Manufacturer should furnish a description of its quality assurance programme including fabrication; testing and inspection for any material (i.e rubber) Components (i.e. rod) or hardware (i.e. end filings). The manufacturer has had fabricated by others should also be included.

Manufacturing methods and material composition documentation will be a part of Technical Bid to be submitted along with offer.

WEATHERSHEDS :

The composite polymer Weathersheds made of silicone elastomeric compound or silicon alloy shall be firmly bonded to the sheath, vulcanized to the sheath or moulded .shall be free from imperfections. The Weathersheds should have silicon content of minimum 30% by weight. The strength of the Weathersheds to sheath interface shall be greater than the tearing strength of the polymer. The interface, if any, between sheds and sheath (housing) shall be free from voids.

METAL END FITTINGS:

End fittings transmit the mechanical load to the core. They shall be made of Malleable Cast Iron or Spherical Graphite Cast Iron. Hardware of respective specified

Rev No.	Description	Prepared By & Date	Checked By & Date	Approved for Issue By & Date
RO		Anil Sah	Niranjan Khuntia	Pourush Garg
		05/08/2020	05/08/2020	05/08/2020



TP Central Odisha Distribution Limited	 TP CENTRAL ODISHA DISTRIBUTION LIMITED	SPECIFICATION FOR SUPPLY OF MATERIAL & CONSTR/AGUMENTATION OF HT/LT LINES, SUBSTATION
NEG-SPEC-01		Date of Issue: 05/08/2020

mechanical load and shall be hot dip galvanized with Zinc coated with minimum 99.95% purity of electrolytic high grade Zinc in accordance with IS 2629. The material used in fittings shall be corrosion resistant.

Metal end fittings shall be uniform and without sharp edges or corners and shall be free of cracks, flakes, silvers, slag, blow-holes shrinkages defects and localized porosity.

They shall be connected to the rod by means of a controlled compression technique. As the main duty of the end fittings is the transfer of mechanical loads to the core the fittings should be property attached to the core by a coaxial or hexagonal compression process and should not damage the individual fibbers or crack the core.

The gap between fittings and sheath shall be sealed by flexible silicone elastometric compound or silicone alloy compound sealant, system of attached of end fitting to the rod shall provide superior sealing performance between housing, i.e. seamless sheath and metal connection. The sealing must be moisture proof.

The dimensions of end fittings of insulators shall be in accordance with the standard dimensions stated in IEC: 60120/IS:2486 Part-II/1989.

The finished surface shall be smooth and shall have a good performance. The surface shall not crack or get chipped due to ageing effect under normal and abnormal service conditions or while handling during transit or erection.

The design of the fittings and the insulators shall be such that there is no local corona formation or discharges likely to cause the interference to either should or vision transmission.

Workmanship :

a ) All the materials shall be of latest design and conform to the best engineering practices adopted in the high voltage filed. Bidders shall offer only such insulators as are guaranteed by them to be satisfactory and suitable for continued good service in power transmission lines.

b ) The design, manufacturing process and material control at various stages shall be such as to give maximum working load, highest mobility, best resistance to corrosion, good finish and elimination of sharp edges and corners.

c ) The design of the insulators shall be such that stresses due to expansion and contraction in any part of the insulator shall not lead to deterioration.

d ) The core shall be sound and free of cracks and voids that may adversely affect the insulators.

e ) Weather sheds shall be uniform in quality. They shall be clean, sound and smooth and shall be free from defects and excessive flashing at parting lines.

Rev No.	Description	Prepared By & Date	Checked By & Date	Approved for Issue By & Date
RO		Anil Sah	Niranjan Khuntia	Pourush Garg
		05/08/2020	05/08/2020	05/08/2020

TP Central Odisha Distribution Limited	 TP CENTRAL ODISHA DISTRIBUTION LIMITED	SPECIFICATION FOR SUPPLY OF MATERIAL & CONSTRN/AGUMENTATION OF HT/LT LINES, SUBSTATION
NEG-SPEC-01		Date of Issue: 05/08/2020

f) End fittings shall be free from cracks, seams, shrinks, air holes and rough edges. End fittings should be effectively sealed to prevent moisture ingress.

Effectiveness of sealing system must be supported by test documents. All surfaces of the metal parts shall be perfectly smooth without projecting points or irregularities, which may cause corona. All load bearing surfaces shall be smooth and uniform so as to distribute the loading stresses uniformly.

g) All ferrous parts shall be hot dip galvanized to give a minimum average coating of zinc equivalent to 610 gm/sq.m. or 87µm thickness and shall be in accordance with the requirement of IS:4579. The zinc used for galvanizing shall be of purity 99.5% as per IS : 4699. The zinc coating shall be uniform, adherent, smooth, reasonably bright continuous and free from imperfections such as flux, ash rust stains, bulky white deposits and blisters. The galvanized metal parts shall be guaranteed to withstand at least four successive dips each lasting for one (1) minute duration under the standard preece test. The galvanizing shall be carried out only after any machining.

Drawing :

The bidder shall furnish along with the bid the outline drawing of each insulator unit including a cross sectional view of the long rod insulator unit. The drawing shall include but not be limited to the following information:

- (a) Long rod diameter with manufacturing tolerances
- (b) Minimum Creepage distance with positive tolerance
- (c) Protected creepage distance
- (d) Eccentricity of the long rod unit
  - (i) Axial run out
  - (ii) Radial run out
- (e) Unit mechanical and electrical characteristics
- (f) Weight of composite long rod units.
- (g) Identification mark
- (h) Manufacturer’s catalogue number

**Marking:** Each insulator shall be legibly and indelibly marked to show the following

- a ) Name & Trade mark of the manufacturer
- b ) Month & Year of manufacturing
- c ) Voltage & Type

Rev No.	Description	Prepared By & Date	Checked By & Date	Approved for Issue By & Date
RO		Anil Sah	Niranjan Khuntia	Pourush Garg
		05/08/2020	05/08/2020	05/08/2020

TP Central Odisha Distribution Limited		SPECIFICATION FOR SUPPLY OF MATERIAL & CONSTRN/AGUMENTATION OF HT/LT LINES, SUBSTATION
NEG-SPEC-01	TP CENTRAL ODISHA DISTRIBUTION LIMITED	Date of Issue: 05/08/2020

d) Minimum Failing Load ( in KN)

**Type Test :** The following Type Test shall have to be conducted as per reference IEC mentioned above on insulator unit, components, materials or complete strings :

- a ) Sudden Load Release Test
- b ) Thermal Mechanical Pre-stress Test
- c ) Dry Positive & Negative Lightning Impulse voltage withstand test
- d ) Dry Positive & Negative Lightning Impulse Flashover voltage test
- e ) Dry & Wet Power Frequency Voltage withstand test
- f ) Dry & Wet Power Frequency Voltage Flashover test
- g ) Mechanical Failing Load test.
- h ) Radio Interference test
- i ) Recovery of Hydrophobicity test.
- j ) Dye Penetration Test.
- k ) Water Diffusion Test
- l ) Chemical composition test for Silicon content
- m ) Brittle facture resistance test.
- n ) Damage Limit proof & Mechanical Withstand Test.

**Routine Test :**

- a ) Identification of marking b ) Visual inspection
- c ) Mechanical routine test

**Acceptance Test :** The following test will be carried out at manufacturers works during inspection of the offered insulators before delivery :

- a ) Visual examination
- b ) Verification of dimension
- c ) Galvanizing test
- d ) Mechanical performance test
- e ) Mechanical Failing Load test

ANNEXURE: A

**Test on Insulator units :**

Rev No.	Description	Prepared By & Date	Checked By & Date	Approved for Issue By & Date
RO		Anil Sah	Niranjan Khuntia	Pourush Garg
		05/08/2020	05/08/2020	05/08/2020

TP Central Odisha Distribution Limited	 TP CENTRAL ODISHA DISTRIBUTION LIMITED	SPECIFICATION FOR SUPPLY OF MATERIAL & CONSTRN/AGUMENTATION OF HT/LT LINES, SUBSTATION
NEG-SPEC-01		Date of Issue: 05/08/2020

1. RIV Test (Dry) : The insulator string along with complete hardware fittings shall have a radio interference voltage level below 100 micro volts at one MHz when subjected to 50 Hz voltage of 10 kV & 30 kV for 11 kV & 33 kV class insulators respectively under dry condition. The test procedure shall be in accordance with IS: 8263/IEC: 437/CISPR 18-2.

2. Brittle Fracture Resistance Test : Brittle fracture test shall be carried out on naked rod along with end fittings by applying “1n HNO3 acid” (63 g conc. HNO3 added to 937 g water) to the rod. The rod should be held at 80% of SML for the duration of the test. The rod should not fail within the 96 Hour test duration. Test arrangement should ensure continuous wetting of the rod with Nitric acid.

3. Recovery of Hydrophobicity & Corona Test :

i) The surface of selected samples shall be cleaned with isopropyl alcohol. Allow the surface to dry and spray with water. Record the Hydrophobicity classification in line with STRI guide for Hydrophobicity classification (Extract enclosed at Annexure-D) Dry the sample surface.

(ii) The sample shall subjected to mechanical stress by bending the Sample over a ground electrode. Corona is continuously generated by applying 12 kV to a needle like electrode placed 1 mm above the sample surface. Tentative arrangement shall be as shown in Annexure-E. The test shall be done for 100 hrs.

(iii) Immediately after the corona treatment, spray the surface with Water and record the HC classification. Dry the surface and repeat The corona treatment as at Clause-2 above. Note HC classification. Repeat the cycle for 1000 Hrs. or until an HC of 6 or 7 is obtained. Dry the sample surface.

(iv) Allow the sample to recover and repeat Hydrophobicity Measurement at several time intervals. Silicone rubber should recover to HC 1

Rev No.	Description	Prepared By & Date	Checked By & Date	Approved for Issue By & Date
RO		Anil Sah	Niranjan Khuntia	Pourush Garg
		05/08/2020	05/08/2020	05/08/2020

<b>TP Central Odisha Distribution Limited</b>		<b>SPECIFICATION FOR SUPPLY OF MATERIAL &amp; CONSTRN/AGUMENTATION OF HT/LT LINES, SUBSTATION</b>
<b>NEG-SPEC-01</b>	<b>TP CENTRAL ODISHA DISTRIBUTION LIMITED</b>	<b>Date of Issue: 05/08/2020</b>

– HC 2 within 24 to 48 hours, depending on the Material and the intensity of the corona treatment.

#### 4. Chemical composition test for Silicon content :

The content of silicon in the composite polymer shall be evaluated by EDX (Energy Dispersion X-ray) Analysis or Thermo-gravimetric analysis. The test may be carried out at CPRI or any other NABL accredited laboratory.

### **General Technical particulars for 11 KV Polymeric Disc Insulator**

	<b>11 KV Disc</b>	<b>To be provided by Bidder</b>
Type of insulator	Polymeric composite Disc Insulator	
Reference Standard	IEC 61109	
Material of FRP Rod	Boron free ECR	
Material of sheds	Silicon Rubber	
Type of metal end fittings	Tongue & Clevis	
Material of end fittings	SGCI / MCI	
Material of sealing compound	RTV Silicon	
Colour of sheds	Grey	
Rated voltage	11 KV	
Highest voltage	12 KV	
Dry Power Frequency Withstand voltage	60 KV	
Wet Power Frequency Withstand voltage	35 KV	
Dry Power Frequency Flashover Voltage	75 KV	
Visible Discharge Voltage (PF)	9 KV	
Wet Power Frequency Flashover	45 KV	
Dry Lightning Impulse withstand	Positive : 75 KV	
Dry Lightning Impulse Flashover	Positive : 95 KV	

Rev No.	Description	Prepared By & Date	Checked By & Date	Approved for Issue By & Date
R0		Anil Sah	Niranjan Khuntia	Pourush Garg
		05/08/2020	05/08/2020	05/08/2020

TP Central Odisha Distribution Limited	 TP CENTRAL ODISHA DISTRIBUTION LIMITED	SPECIFICATION FOR SUPPLY OF MATERIAL & CONSTRN/AGUMENTATION OF HT/LT LINES, SUBSTATION
NEG-SPEC-01		Date of Issue: 05/08/2020

RIV at 1 MHz when energised at 10 KV		
Creepage distance ( min )	320 mm	
Min Failing load	45 KN	
Dia of FRP Rod	16 mm	
Length of FRP Rod ( min )	200 mm	
Dia of weather sheds	100 mm	
Thickness of housing	3 mm	
Dry arc distance	170 mm	
Method of fixing sheds to housing	Injection moulding	
No of weather sheds (min)	Three	
Type of sheds	Aerodynamic	
Type of packing	Wooden/Corrugated	
No of insulator in each pack	Thirty	
Guarantee	12 months from commissioning or 18 months from the date of last despatch.	

Rev No.	Description	Prepared By & Date	Checked By & Date	Approved for Issue By & Date
R0		Anil Sah	Niranjan Khuntia	Pourush Garg
		05/08/2020	05/08/2020	05/08/2020

TP Central Odisha Distribution Limited		SPECIFICATION FOR SUPPLY OF MATERIAL & CONSTRN/AGUMENTATION OF HT/LT LINES, SUBSTATION
NEG-SPEC-01	TP CENTRAL ODISHA DISTRIBUTION LIMITED	Date of Issue: 05/08/2020

**GUARANTEED TECHNICAL PARTICULARS FOR LT GUY STRAIN INSULATOR (TYPE A)**

Sl.	Particulars	Requirement	Bidder's offer
1	Name of Manufacturer. & Address	To be specified by the bidder	
2	Location of type testing	To be specified by the bidder	
3	Applicable standard	IS: 5300-1969 or the latest version thereof	
4	Nominal System Voltage	400/230 V	
5	Highest System voltage	440/250 V	
6	Length	90 mm	
7	Diameter	65 mm	
8	Cable hole diameter	16 ± 1.5	
9	1min. power frequency withstand Voltage (Dry)	18 KV (rms)	
10	1min. power frequency withstand Voltage (Wet)	8 KV	
11	Minimum failing load	44 KN	
12	Minimum creepage distance	41 mm	
13	Drawing	To be submit	
14	Conforming standard	As per IS	

No.	Description	Prepared By & Date	Checked By & Date	Approved for Issue By & Date
		Anil Sah	Niranjan Khuntia	Pourush Garg
		05/08/2020	05/08/2020	05/08/2020



TP Central Odisha Distribution Limited	 TP CENTRAL ODISHA DISTRIBUTION LIMITED	SPECIFICATION FOR SUPPLY OF MATERIAL & CONSTRN/AGUMENTATION OF HT/LT LINES, SUBSTATION
NEG-SPEC-01		Date of Issue: 05/08/2020

**GUARANTEED TECHNICAL PARTICULARS FOR 11 KV GUY STRAIN INSULATOR (TYPE C)**

Sl.	Particulars	Requirement	Bidder's offer
1	Name of Manufacturer. & Address	To be specified by the bidder	
2	Location of type testing	To be specified by the bidder	
3	Applicable standard	IS: 5300-1969 or the latest version thereof	
4	Nominal System Voltage	11 KV	
5	Highest System voltage	12 KV	
6	Length	140 mm	
7	Diameter	85mm	
8	Cable hole diameter	25 ± 1.5	
9	1min. power frequency withstand Voltage (Dry)	27 KV (rms)	
10	1min. power frequency withstand Voltage (Wet)	13 KV	
11	Minimum failing load	88 KN	
12	Minimum creepage distance	57 mm	
13	Drawing	To be submitted by bidder	
14	Conforming standard	As per IS	

No.	Description	Prepared By & Date	Checked By & Date	Approved for Issue By & Date
		Anil Sah	Niranjan Khuntia	Pourush Garg
		05/08/2020	05/08/2020	05/08/2020



TP Central Odisha Distribution Limited		<b>SPECIFICATION FOR SUPPLY OF MATERIAL &amp; CONSTRN/AGUMENTATION OF HT/LT LINES, SUBSTATION</b>
NEG-SPEC-01	TP CENTRAL ODISHA DISTRIBUTION LIMITED	Date of Issue: 05/08/2020

### 40mm dia GI Earthing Device:

#### 1. Scope :-

This specification provides for design, manufacturing, testing before dispatch, supply & delivery of Earthing Device (Heavy Duty) (for use in Sub-station earthing).

#### 2. APPLICABLE STANDARDS :-

The Earthing Device must be made out of 40 mm nominal Bore & 3.2 mm (Medium Gauge- No minus Tolerance allowed) wall thickness Hot Dip G.I. Pipe (as per IS :- 1239,m Part-1, 1990 & REC construction Standard –J-2) , ISI marked of reputed Make & 3 mtrs length tapered finished smooth at one end for a length of 75 mm & Clamp at the other end.

Staggered drills hole of 12 mm Dia of interval of 150mm shall be made before galvanization.

The GI Earthing Clamp/ Strip (C- Clamp Type) is to be of 50mm width, 6mm thickness & flange length of 65 mm in each side. This should be suitable for termination of 4 nos of GI Flat earth electrodes. The Clamp/ Strip & Earthing pipe after fabrication will be hot dip galvanized confirming to IS: 2629/85 with latest amendments. The clamp shall have two holes in both sides suitable for 5/8 x 2" Bolt & provided with two GI bolts& Nuts in each side of 12mm dia 50mm long half threaded with spring washer as per IS: 3043/1982.The galvanization tests are to be conducted as per IS: 2633/72 & IS: 6745/72 & its latest amendments.

### **Guaranteed Technical Particulars of Earthing Device**

(To be submitted along with Offer)

	Par	Bidder's Offer
1.	Location of Factory or Place of Manufacture	
2.	Maker's Name, Address & Country	

No.	Description	Prepared By & Date	Checked By & Date	Approved for Issue By & Date
		Anil Sah	Niranjan Khuntia	Pourush Garg
		05/08/2020	05/08/2020	05/08/2020

TP Central Odisha Distribution Limited		<b>SPECIFICATION FOR SUPPLY OF MATERIAL &amp; CONSTRN/AGUMENTATION OF HT/LT LINES, SUBSTATION</b>
<b>NEG-SPEC-01</b>	TP CENTRAL ODISHA DISTRIBUTION LIMITED	<b>Date of Issue: 05/08/2020</b>

3.	Size of	
A	Pipe	
B	Earthing Strips	
4.	Length (3 mtr. long)	
5.	Thickness of Pipe	
6.	Galvanization Process	
7.	Galvanization thickness	
A	For Earthing device	
B	For Connecting Flat	
8.	Galavanization tests to be conducted as per ISS	
9.	Any other Particulars ( like details of Clamp/ G.I. Bolts)	
10.	Details of Drawings submitted	

### 16 mm dia. Hexagonal Bolts & Nuts and Washer (GI)

16 mm diameter GI Nuts and Bolts black hexagonal As per IS: 1387 (Part-II) Gr.-4/4.6 of following size. Washers shall be round of thickness 1.5 mm suitable for 16 mm dia. bolts.

#### Specification finished products:

1. The bolts & Nuts shall be ISI Marked Mild Steel of Black Grade “B” and shall be round with hexagonal head.
  - (i) The Bolts and Nuts shall be manufactured by Hot/Cold forging process neatly and cleanly finished and shall have metric threads as per IS : 4218/1967 with its latest amendments.
  - (ii) The dimensions of the bolts & nuts and tolerances should conform to IS: 1363 with their latest amendments in all respect. The eccentricity and angular errors of various elements shall be within specified limits as per IS: 1367/1967 with its latest amendments the bolts & nuts shall be free from forging and threading defects such as cuts, spats. burns, bulging taper eccentricity, loose fill etc. which may affect their serviceability.

No.	Description	Prepared By & Date	Checked By & Date	Approved for Issue By & Date
		Anil Sah	Niranjan Khuntia	Pourush Garg
		05/08/2020	05/08/2020	05/08/2020

TP Central Odisha Distribution Limited		SPECIFICATION FOR SUPPLY OF MATERIAL & CONSTRN/AGUMENTATION OF HT/LT LINES, SUBSTATION
NEG-SPEC-01	TP CENTRAL ODISHA DISTRIBUTION LIMITED	Date of Issue: 05/08/2020

(iii) The colt heads and nuts shall be chamfered on one face only and other face shall be machined made.

(iv) Mechanical property requirement of tester shall conform to IS: 1367 (Part-III) 1979 property class 4.6 for bolts & property class-5 for nuts as per IS: 1367 (Part VI) —1980.

(v) The bolts & nuts shall be supplied in well-cleaned conditions and suitably protected against corrosion in individual bags of 50 Kgs.

**ACCEPTANCE TESTS:**

The bidder should furnish test certificate from recognized Govt. Laboratory ( NABL accredited) giving the results of tests as per IS: 1367 (Part-III) —1979 & IS: 1367 (Part-VI) 1980 The test certificate shall be in respect of the following for all sizes of both bolts & nuts as applicable given below:-

- i) Dimensional particulars (Sampling lfl accordance with IS: 2614 for both bolts & nuts (Tolerance as per drawing).
- ii) Tensile strength test on full size (for bolts minimum 400 NI Sq.mm and for Nuts Proof Stress test Mm 610 N/Sq. mm).
- iii) Power load test on full size bolts and M-12-51400 N for 15 Sec.
- iv) Head soundness tests for bolts (no fracture).
- v) Brinell hardness tests or Rockwell Hardness or Vickers’s Hardness tests for bolts min- 114 &max. 209 or mm. 67 & max. 95 or mm. 120 & max. 220 respectively. For nuts Vickers’s Hardness mm. 130 & max. 302.

**Markings:** On the bolt head, there shall be identification marking of the manufacturer as well as property class ‘4.6’.

If possible property class “5” shall be marked on Nuts also. Further ‘ISI’ mark shall be marked on Gunny Bags for proper identification.

No.	Description	Prepared By & Date	Checked By & Date	Approved for Issue By & Date
		Anil Sah	Niranjan Khuntia	Pourush Garg
		05/08/2020	05/08/2020	05/08/2020

TP Central Odisha Distribution Limited	 TP CENTRAL ODISHA DISTRIBUTION LIMITED	SPECIFICATION FOR SUPPLY OF MATERIAL & CONSTR/AGUMENTATION OF HT/LT LINES, SUBSTATION
NEG-SPEC-01		Date of Issue: 05/08/2020

## EARTHING COIL :

### EARHTING COIL TECHNICAL SPECIFICATION

#### SCOPE :

The specification covers design, manufacture, testing and dispatch to the owner's stores of Earthing Coils for use in earthing of the HT & LT poles.

#### GENERAL REQUIREMENTS :

Earthing coils shall be fabricated from soft GI Wire Hot Dip Galvanized. The Hot Dip galvanized wire shall have clean surface and shall be free from paint enamel or any other poor conducting material. The coil shall be made as per REC constructions standard.

The Hot Dip galvanizing shall conform to IS: 2629/1966, 2633/1972 and 4826/1969 with latest amendments.

#### TESTS :

##### Galvanizing Tests

Minimum Mass of Zinc

On GI Wire used 280 cm/m<sup>2</sup>

After Coiling-266 gm/m<sup>2</sup>.The certificate from recognized laboratory shall be submitted towards mas of zinc.

##### Dip Test

Dip test shall stand 3 dips of 1 minute and one dip of ½ minute before coiling and 4 dips of 1 minute after coiling as per IS: 4826/1979

##### Adhesion Test

No.	Description	Prepared By & Date	Checked By & Date	Approved for Issue By & Date
		Anil Sah	Niranjan Khuntia	Pourush Garg
		05/08/2020	05/08/2020	05/08/2020

TP Central Odisha Distribution Limited	 TP CENTRAL ODISHA DISTRIBUTION LIMITED	SPECIFICATION FOR SUPPLY OF MATERIAL & CONSTRN/AGUMENTATION OF HT/LT LINES, SUBSTATION
NEG-SPEC-01		Date of Issue: 05/08/2020

As per ISS 4826 – 1979

**DIMENSIONAL REQUIREMENT**

- i) Nominal dia of GI Wire -4 mm (Tolerance±2.5%)
- ii) Minimum no. of turns – 115 Nos.
- iii) External dia of Coil (Min) – 50 mm
- iv) Length of Coil (Min) – 460 mm
- v) Free length of GI Wire at one end coil (Min.) – 2500 mm
- vi) The turns should be closely bound. Weight of one finished Earthing Coils (min.) – 1.850 Kg.

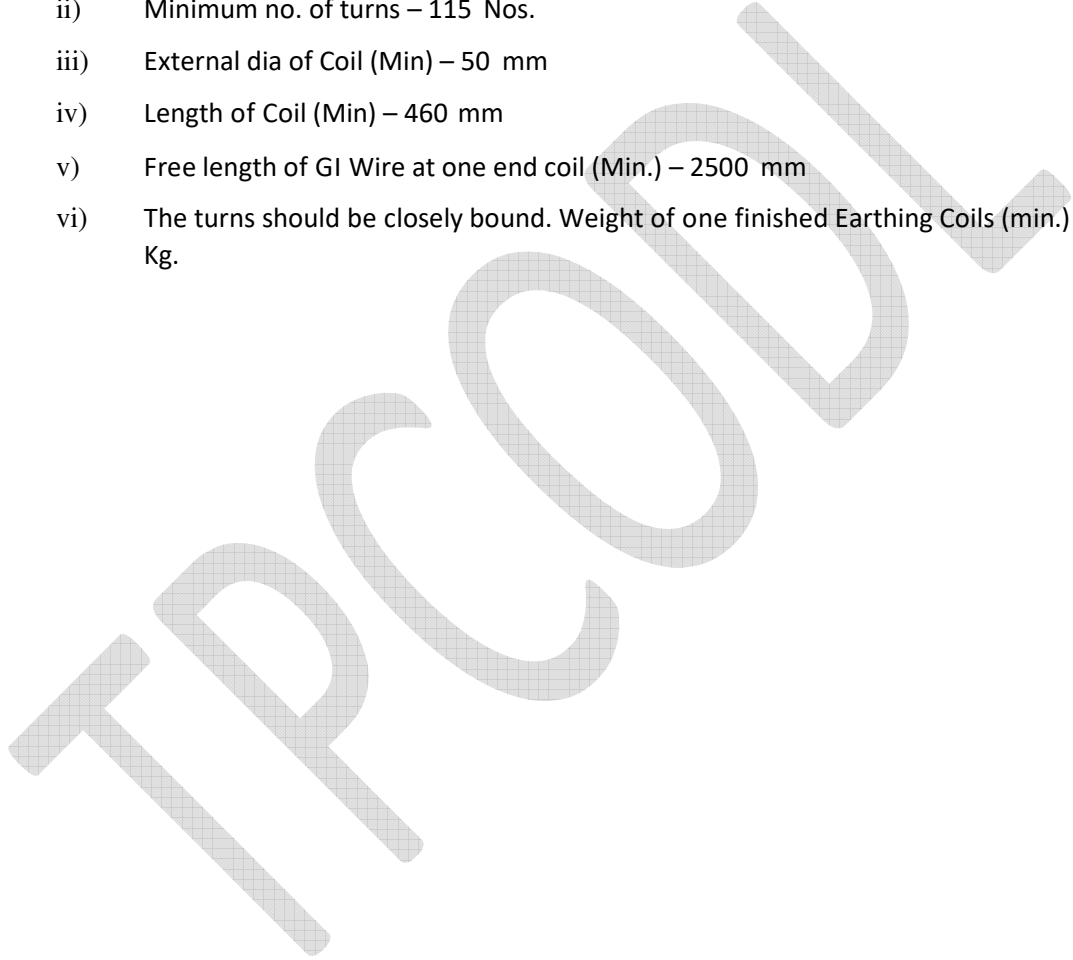

No.	Description	Prepared By & Date	Checked By & Date	Approved for Issue By & Date
		Anil Sah 05/08/2020	Niranjan Khuntia 05/08/2020	Pourush Garg 05/08/2020

TP Central Odisha Distribution Limited		<b>SPECIFICATION FOR SUPPLY OF MATERIAL &amp; CONSTRN/AGUMENTATION OF HT/LT LINES, SUBSTATION</b>
NEG-SPEC-01	TP CENTRAL ODISHA DISTRIBUTION LIMITED	Date of Issue: 05/08/2020

**Guaranteed Technical Particulars of Coil Earth**

Sl. No.	GENERAL TECHNICAL PARTICULARS	Bidder's Offer
1	Nominal diameter of wire	
2	No. of turns	
3	External dia of Coil	
4	Length of Coil	
5	Mass of Zinc	
6	Total weight of Coil	
7	Whether drawing enclosed (yes)	

**STRINGING OF CONDUCTOR**

4.0.1 The works include spreading of conductors without any damage and stringing with proper tension without any kinks/ damage Jumpering at cut points by using two nos., three bolted, PG clamps has to be done. No binding of two conductors with aluminium wires will be allowed. In each and every joints three bolted very good quality PG clamps should be used wrapping of suitable aluminium tapes if required as per the decision of the EE/DE. The ground & line clearances at road crossings along roads other crossings shall be as mentioned in this specification.( which also should not be less than the relevant clearances mentioned in I.E. rules.)

4.0.2 While transporting conductors' drums to site, precautions are to be taken so that the conductor does not get damaged. The drum shall be mounted on cable drum support. The direction of rotation of the drum shall be according to the mark in the drum so that the conductor could be drawn. While drawing the conductor, it shall not rub against surface causing damage. The conductor shall be passed over poles on rubberized or aluminum snatch block (pulley) mounted on the poles for this purpose.

4.0.3 The conductor shall be pulled through come-along clamps to string the conductor between the tension locations.

4.0.4 Conductor splices shall not crack or otherwise be susceptible to damage in the stringing operation. The Contractor shall use only such equipment / methods during conductor stringing which ensures complete compliance in this regard. All the joints including mid span joints on the conductor shall be of the compression type, in accordance with the recommendations of the manufacturer.

4.0.5 All the joints or splices shall be made at least 15 meters away from the pole. No joints or splices shall be made in spans crossing over main roads, railways and small river spans. Not more than one joint per subconductor per span. After compressing the joint, the aluminum sleeve shall have all corners rounded; burrs and sharp edges removed and smoothened.

No.	Description	Prepared By & Date	Checked By & Date	Approved for Issue By & Date
		Anil Sah	Niranjan Khuntia	Pourush Garg
		05/08/2020	05/08/2020	05/08/2020

TP Central Odisha Distribution Limited	 TP CENTRAL ODISHA DISTRIBUTION LIMITED	SPECIFICATION FOR SUPPLY OF MATERIAL & CONSTRN/AGUMENTATION OF HT/LT LINES, SUBSTATION
NEG-SPEC-01		Date of Issue: 05/08/2020

## Technical Specifications :

**100x50x6mm MS Channel 75x40x5 mm  
MS Channel 50x50x6 mm Angle**



No.	Description	Prepared By & Date	Checked By & Date	Approved for Issue By & Date
		Anil Sah 05/08/2020	Niranjan Khuntia 05/08/2020	Pourush Garg 05/08/2020

TP Central Odisha Distribution Limited		SPECIFICATION FOR SUPPLY OF MATERIAL & CONSTRN/AGUMENTATION OF HT/LT LINES, SUBSTATION
NEG-SPEC-01	TP CENTRAL ODISHA DISTRIBUTION LIMITED	Date of Issue: 05/08/2020

Clause No.	<b>TECHNICAL SPECIFICATIONS OF MILD STEEL CHANNEL &amp; ANGLE</b>															
1.0	<p><b>SCOPE</b></p> <p>This specification covers design, manufacture, testing and dispatch to owner’s stores of M.S. Channel &amp; Angle for use in structures in distribution system.</p>															
2.0	<p><b>APPLICABLE STANDARD</b></p> <p>Materials shall conform to the latest applicable Indian standards. In case bidders offer steel section and supports conforming to any other international specifications which shall be equivalent or better than IS, the same is also acceptable.</p> <table border="1" data-bbox="342 821 1396 1100"> <thead> <tr> <th>S.No.</th> <th>Standard No.</th> <th>Title</th> </tr> </thead> <tbody> <tr> <td>1</td> <td>IS: 2062</td> <td>Grade ‘A’ Quality Specification for M.S.Angles, M.S.Channel</td> </tr> <tr> <td>2</td> <td></td> <td></td> </tr> <tr> <td>3</td> <td>IS: 2062</td> <td>Chemical and Physical composition of material</td> </tr> <tr> <td>4</td> <td>IS: 1852</td> <td>Rolling and Cutting Tolerances for Hot Rolled Steel products</td> </tr> </tbody> </table>	S.No.	Standard No.	Title	1	IS: 2062	Grade ‘A’ Quality Specification for M.S.Angles, M.S.Channel	2			3	IS: 2062	Chemical and Physical composition of material	4	IS: 1852	Rolling and Cutting Tolerances for Hot Rolled Steel products
S.No.	Standard No.	Title														
1	IS: 2062	Grade ‘A’ Quality Specification for M.S.Angles, M.S.Channel														
2																
3	IS: 2062	Chemical and Physical composition of material														
4	IS: 1852	Rolling and Cutting Tolerances for Hot Rolled Steel products														
3.0	<p><b>GENERAL REQUIREMENTS</b></p> <p>3.1 <b>Raw material</b></p> <p>The Steel Sections shall be re-rolled from the BILLETS/INGOTS of tested quality as per latest version of IS: 2830 or to any equivalent International Standard and shall be arranged by the bidder from their own sources. The Chemical composition and Physical properties of the finished material shall be as per the equivalent standards.</p>															

No.	Description	Prepared By & Date	Checked By & Date	Approved for Issue By & Date
		Anil Sah	Niranjana Khuntia	Pourush Garg
		05/08/2020	05/08/2020	05/08/2020



<b>TP Central Odisha Distribution Limited</b>		<b>SPECIFICATION FOR SUPPLY OF MATERIAL &amp; CONSTRN/AGUMENTATION OF HT/LT LINES, SUBSTATION</b>
<b>NEG-SPEC-01</b>	<small>TP CENTRAL ODISHA DISTRIBUTION LIMITED</small>	<b>Date of Issue: 05/08/2020</b>

3.2	<b>Length</b> The GS Flat to be supplied shall be in 5.5 meters length.																												
3.3	<b>Weightment</b> The weighnment of GS Flat shall be witnessed by the consignee at the time of taking delivery. The weight recorded in the material receipt certificate issued by the consignees shall be final.																												
3.4	<b>Chemical Composition</b> and Physical Properties of M.S. Angles, M.S. Channels, and M.S.Flat conforming to IS: Conforming to IS:2062/84																												
3.5	<b>Chemical Composition</b> <table style="width: 100%; border-collapse: collapse;"> <thead> <tr> <th style="width: 15%;"></th> <th style="width: 35%; text-align: center;">Chemical composition</th> <th style="width: 30%;"></th> <th style="width: 20%; text-align: center;">For Fe 410 WA Grade</th> </tr> </thead> <tbody> <tr> <td>1</td> <td>C</td> <td style="text-align: center;">-</td> <td style="text-align: center;">0.23% MAX</td> </tr> <tr> <td>2</td> <td>Mn</td> <td style="text-align: center;">-</td> <td style="text-align: center;">1.5% MAX</td> </tr> <tr> <td>3</td> <td>S</td> <td style="text-align: center;">-</td> <td style="text-align: center;">0.050% MAX</td> </tr> <tr> <td>4</td> <td>P</td> <td style="text-align: center;">-</td> <td style="text-align: center;">0.050% MAX</td> </tr> <tr> <td>5</td> <td>SI</td> <td style="text-align: center;">-</td> <td style="text-align: center;">0.40% MAX</td> </tr> <tr> <td>6</td> <td>CE (Carbon Equivalent)-</td> <td></td> <td style="text-align: center;">0.42% MAX</td> </tr> </tbody> </table>		Chemical composition		For Fe 410 WA Grade	1	C	-	0.23% MAX	2	Mn	-	1.5% MAX	3	S	-	0.050% MAX	4	P	-	0.050% MAX	5	SI	-	0.40% MAX	6	CE (Carbon Equivalent)-		0.42% MAX
	Chemical composition		For Fe 410 WA Grade																										
1	C	-	0.23% MAX																										
2	Mn	-	1.5% MAX																										
3	S	-	0.050% MAX																										
4	P	-	0.050% MAX																										
5	SI	-	0.40% MAX																										
6	CE (Carbon Equivalent)-		0.42% MAX																										
3.6	<b>Mechanical Properties</b> 1. Tensile strength Kg/mm <sup>2</sup> – - 410 2. Yield stress Min. for thickness/diameter < 20 mm - 26 Kg/mm <sup>2</sup> OR 250 N/ mm <sup>2</sup> 20-40 mm - 24 Kg/mm <sup>2</sup> OR 240 N/ mm <sup>2</sup> > 40 mm - 23 Kg/mm <sup>2</sup> OR 230 N/ mm <sup>2</sup> 3. Elongation % - 23% 4. Bend Test (Internal Dia) - Min-3t  (t – is the thickness of the material)																												
3.7	<b>Tolerance</b> Variation in ordered quantity for any destination and overall ordered quantity be only to the extent of ±2%. Rolling and weight tolerances shall be as per version of IS: 1852 or to any equivalent International Standard.																												

No.	Description	Prepared By & Date	Checked By & Date	Approved for Issue By & Date
		Anil Sah	Niranjan Khuntia	Pourush Garg
		05/08/2020	05/08/2020	05/08/2020

<b>TP Central Odisha Distribution Limited</b>		<b>SPECIFICATION FOR SUPPLY OF MATERIAL &amp; CONSTRN/AGUMENTATION OF HT/LT LINES, SUBSTATION</b>
<b>NEG-SPEC-01</b>	<small>TP CENTRAL ODISHA DISTRIBUTION LIMITED</small>	<b>Date of Issue: 05/08/2020</b>

<p>4.0</p>	<p><b>TEST</b></p> <p>Steel Section shall be tested in IS approved Laboratory or Standard Laboratory the Bidder country having all facilities available for conducting all the test prescribed in relevant IS or IEC or to any equivalent International Standard or any recognized and reputable International Laboratory or Institutions.</p> <p>The bidders are required to specifically indicate that;</p> <ul style="list-style-type: none"> <li>i) They hold valid IS (or equivalent IEC) License.</li> <li>ii) Steel Section offered are bearing requisite IS certification or equivalent marks.</li> </ul> <p>The bidders are required to submit a copy of the valid IS (or equivalent IEC) License clearly indicating size and range of product against respective ISS or any equivalent International Standards along with their offer.</p>
<p>5.0</p>	<p><b>MARKING</b></p> <p>It is desirable that the bidder should put his identification marks on the finished material. The mark shall be in “legible English letter” given with marking dies of minimum 18 mm size.</p>
<p>6.0</p>	<p><b>INSPECTION AND TEST CERTIFICATES</b></p> <p>The material to be supplied will be subject to inspection and approval by the purchaser’s representative before dispatch and/or on arrival at the destination. Inspection before dispatch shall not however, relieve the bidder of his responsibility to supply the Steel Sections strictly in accordance with the specification.</p>

No.	Description	Prepared By & Date	Checked By & Date	Approved for Issue By & Date
		Anil Sah	Niranjan Khuntia	Pourush Garg
		05/08/2020	05/08/2020	05/08/2020

TP Central Odisha Distribution Limited		SPECIFICATION FOR SUPPLY OF MATERIAL & CONSTRN/AGUMENTATION OF HT/LT LINES, SUBSTATION
NEG-SPEC-01	TP CENTRAL ODISHA DISTRIBUTION LIMITED	Date of Issue: 05/08/2020

## Barbed Wire

### TECHNICAL SPECIFICATION FOR G.I. BARBED WIRE

#### STANDARDS:

Unless otherwise specified elsewhere in this specification, the rating as well as performance and testing of the G.I.Barbed wire shall conform to the latest revisions available at the time of placement of order of all the relevant standards but not limited to as listed below.

- IS:280:1978 Mild steel wire for general engineering purposes (*third revision*)  
 IS:1340:1977 Code of practice for chromate conversion coating of zinc and cadmium coated articles and zinc base alloys (*first revision*)  
 IS:1521:1972 Method for tensile testing of steel wire (*first revision*)  
 IS:1755:1983 Method for wrapping test for metallic wire (*first revision*)  
 IS:2633:1986 Method for testing uniformity of coating of zinc coated articles(*second revision*) IS:4826:1979 Hot dipped galvanized coating on round steel wires (*first revision*) IS:12753:1989 Electro galvanized coatings on round steel wire – Specification

#### 1. GENERAL TECHNICAL REQUIREMENTS:

GI Barbed wire shall be 2 PLY with a 2.5mm diameter. The barbs shall have a 2mm diameter and be 12.5mm in length. The barbs shall have four points and shall be formed by twisting two point wires, each two turns, tightly around both line wires making altogether four complete turns.

G.I. Barbed wire shall be of type IOWA with size and dimensions as under:-

- Line wire - 2.5 mm  
 Point wire - 2.0 mm

Distance between two bars shall be 75 mm ( + 12 mm ).

No.	Description	Prepared By & Date	Checked By & Date	Approved for Issue By & Date
		Anil Sah	Niranjan Khuntia	Pourush Garg
		05/08/2020	05/08/2020	05/08/2020

TP Central Odisha Distribution Limited		SPECIFICATION FOR SUPPLY OF MATERIAL & CONSTRN/AGUMENTATION OF HT/LT LINES, SUBSTATION
NEG-SPEC-01	TP CENTRAL ODISHA DISTRIBUTION LIMITED	Date of Issue: 05/08/2020

**SPECIFIC TECHNICAL PARTICULARS FOR 2.5 MM X 2.0 MM G.I.BARBED WIRE**

Sl.No.	Particulars	Particulars Specified	Bidders Offer
1	Size of wire- mm	Line wire- 2.5 mm + 0.08 mm Point wire- 2.0 mm + 0.08 mm	
2	Type of Barbed Wire	lowa Type	
3	Tensile strength of line wire	390 to 590 N/mm <sup>2</sup>	
4	Minimum breaking load of completed Barbed	3.7 KN	
5	Mass of complete Barbed wire (minimum)	115 gms / Mtr.	
6	Distance between two Barbs	(75 + 12 ) mm	
7	No. of lays between the	4	
8	Method of Galvanising	Hot dipped according to IS:4826	
9	Mass of coating (minimum)	Line wire- 110 gms/Mtr <sup>2</sup> Point	
10	No. of dips the wire is able to	( testing after barbing )	
	A) For Line Wire	2 dip in Min	
	B) For Point Wire	2 dip in Min	

No.	Description	Prepared By & Date	Checked By & Date	Approved for Issue By & Date
		Anil Sah	Niranjan Khuntia	Pourush Garg
		05/08/2020	05/08/2020	05/08/2020

TP Central Odisha Distribution Limited		SPECIFICATION FOR SUPPLY OF MATERIAL & CONSTRN/AGUMENTATION OF HT/LT LINES, SUBSTATION
NEG-SPEC-01	TP CENTRAL ODISHA DISTRIBUTION LIMITED	Date of Issue: 05/08/2020

## Technical Specifications for 3pole 200A H.G Fuse Set

1. **SCOPE:-** This specification covers the manufacture, testing and supply of 11 3 pole 200A H.G. Fuse Sets.
2. (a) The 11 KV H.G. Fuses shall be suitable for out door operation in horizontal configuration under the climatic conditions specified. It shall be of the following ratings:-

1	Number of Poles	3
2	No.of Insulator per Pole	2 nos. 12 KV post Insulators
3	Nominal system Voltage	11 KV
4	Highest System of Voltage	12 KV
5	Rated frequency	50 Hz
6	System Frequency	Effectively earthed
7	Rated normal current	200 Amps
8	Altitudes of installation	Not exceeding 1000 M.

- (b) The post insulator used in the H.G. Fuse set shall have the following ratings :-

1)	Power frequency withstand voltage	33 KV (RMS)
2)	Power frequency withstand voltage	35 KV (RMS)
3)	Impulse withstand voltage (dry)	75 KV (Peak)

4)	Power frequency withstand voltage	1.3 times the actual dry flashover voltage of the unit
----	-----------------------------------	--

No.	Description	Prepared By & Date	Checked By & Date	Approved for Issue By & Date
		Anil Sah	Niranjan Khuntia	Pourush Garg
		05/08/2020	05/08/2020	05/08/2020

TP Central Odisha Distribution Limited		SPECIFICATION FOR SUPPLY OF MATERIAL & CONSTR/AGUMENTATION OF HT/LT LINES, SUBSTATION
NEG-SPEC-01	TP CENTRAL ODISHA DISTRIBUTION LIMITED	Date of Issue: 05/08/2020

#### 4 STANDARDS :-

The H.G. Fuse set shall confirm to the following standards.

IS- 9385-1980 ( for high voltage expulsion fuses and similar fuses).

IS- 2544-1973 ( for porecelain post insulators or its latest amendments if any.).

IS- 2633-1979 ( for Galvanisation of ferrous parts).

3. **INSULATOR MAKE :-** 12 KV post insulator complete with pedestal cap duly cemented to be used in 11 KV H.G. Fuse sets confirming to IS-2544/1973.
4. **TECHNICAL DETAILS :-** The H.G. Fuses shall have adjustable arcing horns made of solid copper rod having 7.62 mm dia. The horns shall be fitted with screwing devices with flynuts for fixing and tightening the fuse wire. It shall have robust terminal connectors of size 80 mm x 50 mm x 6 mm made of copper casting (95 % minimum copper composition) duly silver plated with two numbers of 12 mm dia brass bolts and double nuts with flat brass washers. The connectors should be capable of connecting crimpable conductor upto 80 Sq. mm size( ACSR/ Alloy) with bimetallic solderless sockets. The H.G Fuse Set shall suitable for horizontal mounting on sub-station structures. The minimum clearance between the adjacent phases of the fuse set shall be 760 mm and the centre to centre (distance between two post insulators of the same phase) shall be 410 mm. All metal (ferrous) parts shall be galvanized and polished. Only 12 KV post insulator ( original cemented and not pin insulators shall be used for the H.G. Fuse Set.
5. **CLIMATIC CONDITIONS :-** The H.G. fuse set shall be suitable for operation under the following climatic conditions.:-

1	Maximum ambient air temperature	45 <sup>0</sup> C
2	Maximum daily average air temperature	35 <sup>0</sup> C
3	Maximum yearly average ambient air temperature	30 <sup>0</sup> C
4	Maximum temperature attainable by a body exposed to the sun.	50 <sup>0</sup> C
5	Minimum ambient air temperature	0 <sup>0</sup> C
6	Maximum relative humidity	100%
7	Average number of thunderstorm days per annum	70 days
8	Average number of rainy days per annum	120
9	Average annual rain fall.	150CM
10	Number of months of tropical monsoon conditions	4
11	Maximum wind pressure	260 Kg/mm
12	Degree of exposure to atmospheric pollution.	Normally polluted atmosphere.

No.	Description	Prepared By & Date	Checked By & Date	Approved for Issue By & Date
		Anil Sah	Niranjan Khuntia	Pourush Garg
		05/08/2020	05/08/2020	05/08/2020

TP Central Odisha Distribution Limited		SPECIFICATION FOR SUPPLY OF MATERIAL & CONSTRN/AGUMENTATION OF HT/LT LINES, SUBSTATION
NEG-SPEC-01	TP CENTRAL ODISHA DISTRIBUTION LIMITED	Date of Issue: 05/08/2020

## 7 Type Test :-

Certificate for the following type tests conducted on a prototype set of HG Fuse in a NABL approved test house/CPRI shall have to be submitted along with offer.

- i) Impulse voltage dry test
- ii) Power frequency voltage dry test
- iii) Power frequency voltage wet test
- iv) Temperature of resistance.
- v) Test to prove the capability of carrying the rated peak short circuit current and the rated short time current.
- vi) Mainly active load breaking capacity test.
- vii) Transformer off-load breaking test.
- viii) Line charging breaking capacity test.
- ix) Operation tests.
- x) Mechanical endurance test.
- xi) Mechanical strength test for the post insulator as per IS:2544/1973, 5350 (Pt-II)/1970 & relevant IEC.
- xii) Test for galvanization of metal (ferrous) parts as per IS- 2633/1973.

### ROUTINE/ACCEPTANCE TESTS :-

The inspection may be carried out by the Purchaser at any stage of manufacture. The successful bidder shall grant free access to the Purchaser's representative at a reasonable time when the work is in progress. The following routine tests shall have to be conducted on each set and results are to be furnished for consideration of deputing inspecting officer for inspection and conduction testing of the materials at the works of the manufacturer. the supplier shall give fifteen days advance intimation to the Purchaser to enable him to depute his representative for witnessing the tests.

- i) Power frequency voltage dry test
- ii) Dimension Check
- iii) Galvanisation test.

No.	Description	Prepared By & Date	Checked By & Date	Approved for Issue By & Date
		Anil Sah	Niranjan Khuntia	Pourush Garg
		05/08/2020	05/08/2020	05/08/2020



TP Central Odisha Distribution Limited		<b>SPECIFICATION FOR SUPPLY OF MATERIAL &amp; CONSTRN/AGUMENTATION OF HT/LT LINES, SUBSTATION</b>
NEG-SPEC-01	TP CENTRAL ODISHA DISTRIBUTION LIMITED	Date of Issue: 05/08/2020

**9. Guaranteed Technical Particulars :**

The bidders are required to furnish the guaranteed technical particulars duly filed in the proforma along with the bid.

**10. Completeness of Equipment :**

Any fittings accessories or apparatus which may not have been specifically mentioned in this specification but which are usually necessary in equipment of similar plant shall be deemed to be included in the specification and shall be supplied by the bidder without extra charge. All plant and equipment shall be complete in all details whether such details are mentioned in the specification or not.

**11. Inspection :**

Routine and acceptance test shall be conducted at the place of manufacturer. The bidders are requested to furnish details of equipments which will be used for testing along with the bid. The bids of these manufacturers who do not have adequate testing facilities for conducting routine and acceptance test are liable for cancellation. The successful bidder has to furnish routine test certificate and guarantee certificate for each consignment of materials to be inspected at the time of offer of materials for inspection.

**GUARANTEED TECHNICAL PARTICULARS OF 11 KV 200Amp. HG**

**Fuse (2 / 3 pole)**

Sl. No	Particulars	Requirement	Bidders offer	
		11 KV 200 Amps./ 3 pole H.G Fuse.	3POLE	
1	Maker's name & Address	To be specified by the bidder		
2	Operating voltage	11 KV		
3	No. of Post Insulators per phase	2 nos. of 12 KV Post Insulators per phase as per ISS:2544/1973		
4	Rated normal current & normal frequency	200 Amp., 50 Hz		
5	Vertical clearance from the top of insulator to mounting channel	254 mm (minimum)		
	Rated Breaking capacity	<b>10KA</b>		
	Length of fuse Barrel	<b>285mm</b>		

No.	Description	Prepared By & Date	Checked By & Date	Approved for Issue By & Date
		Anil Sah	Niranjan Khuntia	Pourush Garg
		05/08/2020	05/08/2020	05/08/2020



TP Central Odisha Distribution Limited	 TP CENTRAL ODISHA DISTRIBUTION LIMITED	SPECIFICATION FOR SUPPLY OF MATERIAL & CONSTRN/AGUMENTATION OF HT/LT LINES, SUBSTATION
NEG-SPEC-01		Date of Issue: 05/08/2020

6	Height of the riser for carrying the horn.	150 mm from the cap top of insulator		
7	<b>Post Insulators :</b>			
(a)	Maker's Name & Country of Manufacture of Post Insulator	To be specified by the bidder ( as per CPRI Test Report).		
(b)	Type of cementing	Original Cementing only as per IS: 2544/1973 & relevant IEC.		
(c)	1 minute Power frequency withstand	35KV RMS		
(d)	1 minute Power frequency withstand	35KV RMS		
(e)	Visible discharge voltage	9KV RMS		
(f)	Dry flash over voltage	85 KV RMS		
(g)	Power frequency puncture withstand voltage	1.3 times of actual dry flash over voltage (110 KV) .		
(h)	Creepage distance	320 mm (minimum). Actual creepage distance for which type test has been conducted is to be supplied.		
8.	Impulse withstand voltage for positive & negative polarity (1.2/50 micro second wave)			
(a)	Across the isolating distance	85KV (Peak)		
(b)	To earth & between poles	75KV (Peak)		
9.	One minute Power frequency			
(a)	Across the Isolating distance	32KV(RMS)		
(b)	To earth & between poles	28KV(RMS)		
10	Details of Arcing Horn	1 SWG (7.62 mm) dia. solid copper		
11	Riser Unit (150 mm height	a) Riser cum Connector made out of		
		b) 100 mm height G.I Riser made of		
13.	Galvanization	a) All ferrous parts shall be hot-		
14	Supporting Channel	75mmx40mmx6mm M.S.Channel.		
15	Weight of each pole	16 Kg (Approx.)To be specified by		
16	Detailed drawing submitted ?	To be provided by bidders		
i) Ferrous parts shall be duly galvanized as per IS :2629/1985(1st. Revision), (Amendment-2) and non-ferrous parts shall be silver plated.				

No.	Description	Prepared By & Date	Checked By & Date	Approved for Issue By & Date
		Anil Sah	Niranjan Khuntia	Pourush Garg
		05/08/2020	05/08/2020	05/08/2020

TPCODL

No.	Description	Prepared By & Date	Checked By & Date	Approved for Issue By & Date
		Anil Sah	Niranjana Khuntia	Pourush Garg
		05/08/2020	05/08/2020	05/08/2020



**Technical Specification  
For  
DANGER BOARD**

**TP Central Odisha Distribution Limited.  
Network Engineering Group  
2<sup>nd</sup> Floor, IDCO Tower  
Janpath, Bhubaneswar- 751022**

Rev No.	Description	Prepared By & Date	Checked By & Date	Approved for Issue By & Date
R0	Specifications for DANGER BOARD	Sayantani Das	Niranjan Khuntia	Pourush Garg
		05/08/2020	05/08/2020	05/08/2020

<b>TP Central Odisha Distribution Limited</b>	 TP CENTRAL ODISHA DISTRIBUTION LIMITED	<b>SPECIFICATION FOR DANGER BOARD</b>
<b>NEG-SPEC-16</b>		<b>Date of Issue: 05/08/2020</b>

## CONTENTS

1. SCOPE
2. APPLICABLE STANDARDS
3. CLIMATIC CONDITIONS OF THE INSTALLATION
4. GENERAL TECHNICAL REQUIREMENTS
5. GENERAL CONSTRUCTIONS
6. MARKING
7. TESTS
8. TYPE TEST CERTIFICATES
9. PRE-DISPATCH INSPECTION
10. INSPECTION AFTER RECEIPT AT STORES
11. GUARANTEE
12. PACKING
13. TENDER SAMPLE
14. QUALITY CONTROL
15. MINIMUM TESTING FACILITIES
16. MANUFACTURING ACTIVITIES
17. SPARES, ACCESSORIES AND TOOLS
18. DRAWINGS AND DOCUMENTS
19. GUARANTEED TECHNICAL PARTICULARS
20. SCHEDULE OF DEVIATIONS

Rev No.	Description	Prepared By & Date	Checked By & Date	Approved for Issue By & Date
R0	Specifications for DANGER BOARD	Sayantani Das	Niranjan Khuntia	Pourush Garg
		05/08/2020	05/08/2020	05/08/2020

<b>TP Central Odisha Distribution Limited</b>	 <b>TPCODL</b>	<b>SPECIFICATION FOR DANGER BOARD</b>
<b>NEG-SPEC-16</b>	<small>TP CENTRAL ODISHA DISTRIBUTION LIMITED</small>	<b>Date of Issue: 05/08/2020</b>

1	SCOPE	This specification covers technical requirements of design, manufacture, testing at manufacturer's works, packing, forwarding, supply and unloading at stores/site, performance of danger plates		
2	APPLICABLE STANDARDS	The equipment covered by this specification shall unless otherwise stated, be designed, manufactured and tested in accordance with the latest editions of the following Indian, International Standards and shall conform to the regulations of the local authorities. The danger plate shall comply with the Indian Standard IS 2551- 1982		
3	CLIMATIC CONDITIONS OF THE INSTALLATION	<p>The service conditions shall be as follows:</p> <ol style="list-style-type: none"> <li>1. Maximum altitude above sea level 1,000m</li> <li>2. Maximum ambient air temperature 50°C</li> <li>3. Maximum daily average ambient air temperature 35°C</li> <li>4. Minimum ambient air temperature 0°C</li> <li>5. Maximum relative humidity 95%</li> <li>6. Average number of thunderstorm days per annum (isokeraunic level) 70</li> <li>7. Average number of rainy days per annum 120</li> <li>8. Average annual rainfall 150cm</li> <li>9. Earthquakes of an intensity in horizontal direction - equivalent to seismic acceleration of 0.3g</li> <li>10. Earthquakes of an intensity in vertical direction - equivalent to seismic acceleration of 0.15g (g being acceleration due to gravity)</li> <li>11. Wind velocity: 300 km/hr, 200 km/hr and 160 km/hr. environmentally, some of the regions, where the work will take place includes coastal areas, subject to high relative humidity, which can give rise to condensation. Onshore winds will frequently be salt laden. On occasions, the combination of salt and condensation may create pollution conditions for outdoor insulators. Some places are in heavily industrial polluted areas. Therefore, Outdoor material and equipment shall be designed and protected for use in exposed, heavily polluted, salty, corrosive and humid coastal atmosphere</li> <li>12. The design of equipment and accessories shall be suitable to withstand seismic forces corresponding to an acceleration of 0.1 g.</li> </ol>		
4	GENERAL TECHNICAL REQUIREMENTS	DESCRIPTION	UNI TS	REQUIREMENTS
		1 Plate material		Mild steel
		2 Plate thickness, min	mm	1.6
		3 Front side paint		Vitreous enameled white
		4 Letters/ figure/skull/cross bones colour		Red color
		5 Rear side of plate		enamelled
		6 Dimension	mm	250 x200
		7 Corners of the plate		Rounded off
5	GENERAL CONSTRUCTIONS	<p>5.1. Dimensions:</p> <p>5.1.1 For 415V, 11kV, and 33kV voltage installations: 250x200mm (see figure given in Annexure).</p> <p>5.1.2 All letterings shall be centrally spaced. The dimensions of the letters, figures and their respective positions shall be as given in figure. The size of each letter in the word in each language, and the spacing between them for purposes of scribing shall be so chosen that they are uniformly written in the space earmarked for them.</p> <p>5.1.3 The corners of the plate shall be rounded off.</p> <p>5.1.4 The locations of the fixing holes shall be left to the choice of the user.</p> <p>LANGUAGES</p> <p>ENGLISH: for denoting in English, the type of lettering recommended is as shown in the figure.</p> <p>Local Language: for denoting in Local Language, the type of lettering recommended is as shown in the figure.</p>		

Rev No.	Description	Prepared By & Date	Checked By & Date	Approved for Issue By & Date
R0	Specifications for DANGER BOARD	Sayantani Das	Niranjan Khuntia	Pourush Garg
		05/08/2020	05/08/2020	05/08/2020

<b>TP Central Odisha Distribution Limited</b>	 <b>TPCODL</b>	<b>SPECIFICATION FOR DANGER BOARD</b>
<b>NEG-SPEC-16</b>	<small>TP CENTRAL ODISHA DISTRIBUTION LIMITED</small>	<b>Date of Issue: 05/08/2020</b>

6	NAME PLATE AND MARKING	<p>The essential information that would be necessary to identify the manufacturer of the danger board plates shall be marked, in such a manner and position on the plates that it does not interfere with the other information.</p> <p>The danger board plates shall also be marked with ISI certification mark.</p> <p>“PROPERTY OF TATA POWER COMPANY LIMITED, BUBANESHWAR” to be written in blue color (PANTONE 300C) along with the logo.</p>
7	TESTS	<p><b>General</b></p> <p>7.0.1 In order to ensure that the notice plates conform to this specification, the following essential tests are specified. The number of samples to be tested shall be as agreed to between the supplier and the user.</p> <p>7.0.2 the following shall constitute the tests:</p> <p>a) Visual examination b) Dimensional check, and c) Test for weather proofness.</p> <p>7.1 Visual Examination</p> <p>The samples of notice shall be examined visually for conformity to the various requirements of this standard in respect of the works and letters used their relative positive and size. The colour of the paint used shall be visually compared with the signal red colour as specified in IS:5-1978</p> <p>7.2 Dimensional Check</p> <p>The dimension of the plate, its thickness and the size of lettering, figures, etc. shall conform generally to the stipulations in 5.1.2 to 5.1.4</p> <p>7.3 Tests for weather proofness</p> <p>For the purpose of verifying colour retention of the vitreous enamel coatings, the method of test specified in IS 8709-1977 shall apply.</p>
8	TYPE TEST CERTIFICATES	Supplies shall be tested and five duly attested/certified copies of test certificates for respective items shall be submitted for approval and issuing Material Dispatch Clearance Certificate called MDCC.
9	PRE-DISPATCH INSPECTION	<p>A) TESTS: the material shall be subjected to following tests:</p> <p>1) Visual Inspection</p> <p>B) The Material shall be subject to inspection by a duly authorized representative of the TPCL, Bhubaneshwar. Inspection may be made at any stage of manufacture at the discretion of the purchaser and the equipment, if found unsatisfactory as to workmanship or material, the same is liable to rejection. Bidder shall grant free access to the places of manufacture to TPCL's representatives at all times when the work is in progress. Inspection by the TPCL or its authorized representatives shall not relieve the bidder of his obligation of furnishing equipment in accordance with the specifications. Material shall be dispatched after specific MDCC (Material Dispatch Clearance Certificate) is issued by TPCL, Bhubaneshwar.</p> <p>Following documents shall be sent along with material:</p> <p>a. Test reports b. MDCC issued by TPCL, Bhubaneshwar c. Invoice in duplicate d. Packing list e. Drawings &amp; catalogue f. Guarantee / Warrantee card g. Delivery Challan h. Other Documents (as applicable).</p>

Rev No.	Description	Prepared By & Date	Checked By & Date	Approved for Issue By & Date
R0	Specifications for DANGER BOARD	Sayantani Das	Niranjan Khuntia	Pourush Garg
		05/08/2020	05/08/2020	05/08/2020

<b>TP Central Odisha Distribution Limited</b>	 <b>TPCODL</b> TP CENTRAL ODISHA DISTRIBUTION LIMITED	<b>SPECIFICATION FOR DANGER BOARD</b>
<b>NEG-SPEC-16</b>		<b>Date of Issue: 05/08/2020</b>

10	INSPECTION AFTER RECEIPT AT STORES	The material received at TPCL, Bhubaneshwar store will be inspected for acceptance and shall be liable for rejection, if found different from the reports of the pre-dispatch inspection and one copy of the report shall be sent to Engineering & Contracts department
11	GUARANTEE	11 Bidder shall stand guarantee towards design, materials, workmanship & quality of process/ manufacturing of items under this contract for due and intended performance of the same, as an integrated product delivered under this contract. In the event any defect is found by the Purchaser up to a period of at least 12 months from the date of commissioning or 24 months from the date of last supplies made under the contract whichever is later, (the time scale of 12/24 months could be enhanced subject to mutual agreements). Bidder shall be liable to undertake to replace/rectify such defects at its own costs, within mutually agreed time frame, and to the entire satisfaction of the Purchaser, failing which the Purchaser will be at liberty to get it replaced/rectified at Bidder's risks and costs and recover all such expenses plus the Purchaser's own charges (@ 20% of expenses incurred), from the Bidder or from the "Security cum Performance Deposit" as the case may be. Bidder shall further be responsible for 'free replacement' for another period of THREE years from the end of the guarantee period for any 'Latent Defects' if noticed and reported by the Purchaser
12	PACKING	Suppliers shall ensure that all the equipments covered by this specification shall be prepared for rail/road transport (local equipment) and be packed in such a manner as to protect it from damage in transit.
13	TENDER SAMPLE	As and when required.
14	QUALITY CONTROL	The bidder shall submit with the offer Quality assurance plan indicating the various stages of inspection, the tests and checks which will be carried out on the material.
15	TESTING FACILITIES	Supplier/Manufacturer shall have adequate in house testing facilities for carrying out all routine tests & acceptance tests as per relevant International / Indian standards.
16	MANUFACTURING ACTIVITIES	The successful bidder will have to submit the bar chart for various manufacturing activities clearly elaborating each stage, with quantity. This bar chart should be in line with the Quality assurance plan submitted with the offer. This bar chart will have to be submitted within 15 days from the release of the order
17	SPARES, ACCESSORIES AND TOOLS	The bidder shall provide a list of complete set of accessories and tools required for erection and maintenance of danger board plate along with the installation procedure
18	DRAWINGS AND DOCUMENTS	Following documents shall be prepared based on TPCL specifications and statutory requirements with complete BOM and shall be submitted with the bid: a) Completely filled in Technical Particulars. b) General description of the equipment and all components including brochures. c) Type test Certificates d) Experience List. After the after of the contract, four (4) copies of the drawings, drawn to scale, describing the equipment in detail shall be forwarded for approval and shall subsequently provide four (4) complete sets of final drawings, one of which shall be auto positive suitable for reproduction, before the dispatch of the equipment. Soft copy (Compact Disk CD) of all the drawing, GTP, test certificates shall be submitted after the final approval of the same to the purchaser.

Rev No.	Description	Prepared By & Date	Checked By & Date	Approved for Issue By & Date
R0	Specifications for DANGER BOARD	Sayantani Das	Niranjan Khuntia	Pourush Garg
		05/08/2020	05/08/2020	05/08/2020



19	GENERAL TECHNICAL PARTICULARS		DESCRIPTION	UNITS	REQUIREMENTS
		1	Plate material		To be furnished by the bidder.
		2	Plate thickness, min	mm	
		3	Front side paint		
		4	Letters/ figure/skull/cross bones colour		
		5	Rear side of plate		
		6	Dimension	mm	
7	Corners of the plate				

20	<p><b>SCHEDULE OF DEVIATIONS</b> <b>(TO BE ENCLOSED WITH TECHNICAL BID)</b></p> <p>All deviations from this specification shall be set out by the Bidders, clause by Clause in this schedule. Unless specifically mentioned in this Schedule, the tender shall be deemed to confirm the purchaser's specifications:</p>		
	<b>S. No</b>	<b>Clause No.</b>	<b>Details of deviation with justifications</b>
	<p>We confirm that there are no deviations apart from those detailed above. Seal of the Company:</p>		

Rev No.	Description	Prepared By & Date	Checked By & Date	Approved for Issue By & Date
R0	Specifications for DANGER BOARD	Sayantani Das	Niranjan Khuntia	Pourush Garg
		05/08/2020	05/08/2020	05/08/2020

ANNEXURE

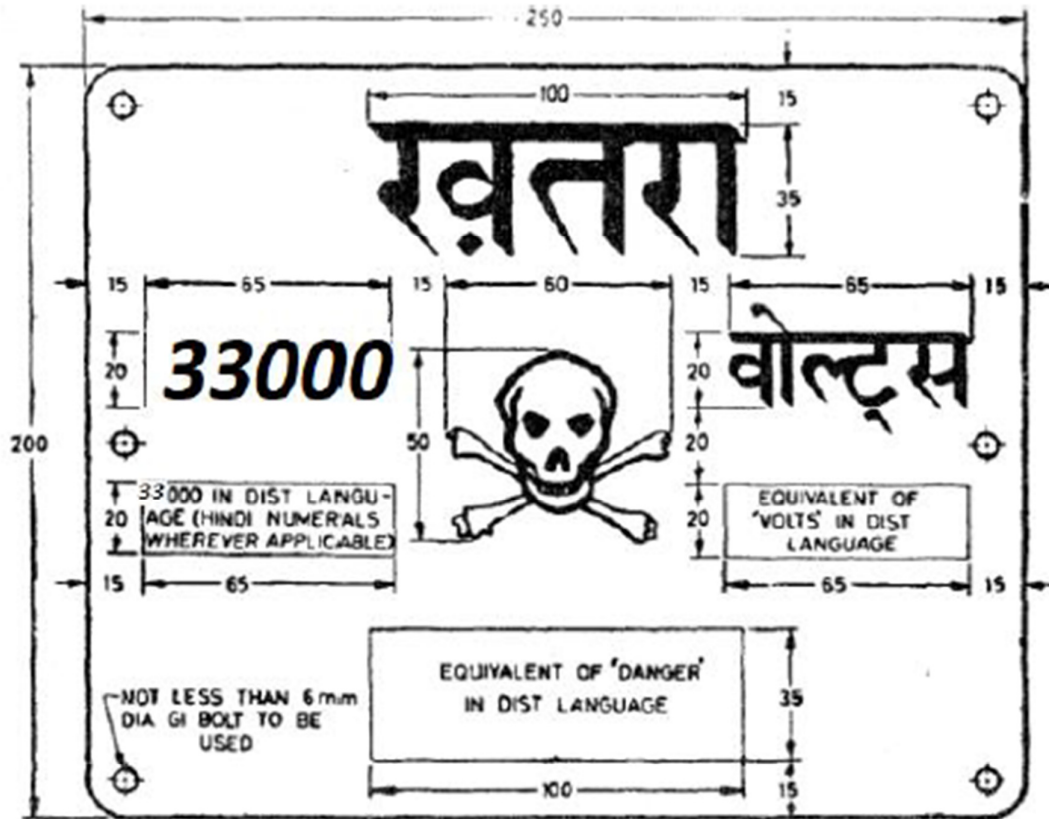

NOTE 1 — All letterings should be centrally spaced.  
NOTE 2 — The dimensions for the words in district language are mainly for guidance, however, care should be taken to space them centrally between the edges and the area of the skull and bones.

NOTE 3 — The location of the fixing holes shall be left to the choice of the user.  
NOTE 4 — 33 000 volts is just specimen, actual voltage is to be inserted for different system voltages.  
NOTE 5 — The corners of the plates should be rounded off.

All dimensions in millimetres.

Rev No.	Description	Prepared By & Date	Checked By & Date	Approved for Issue By & Date
R0	Specifications for DANGER BOARD	Sayantani Das	Niranjan Khuntia	Pourush Garg
		05/08/2020	05/08/2020	05/08/2020

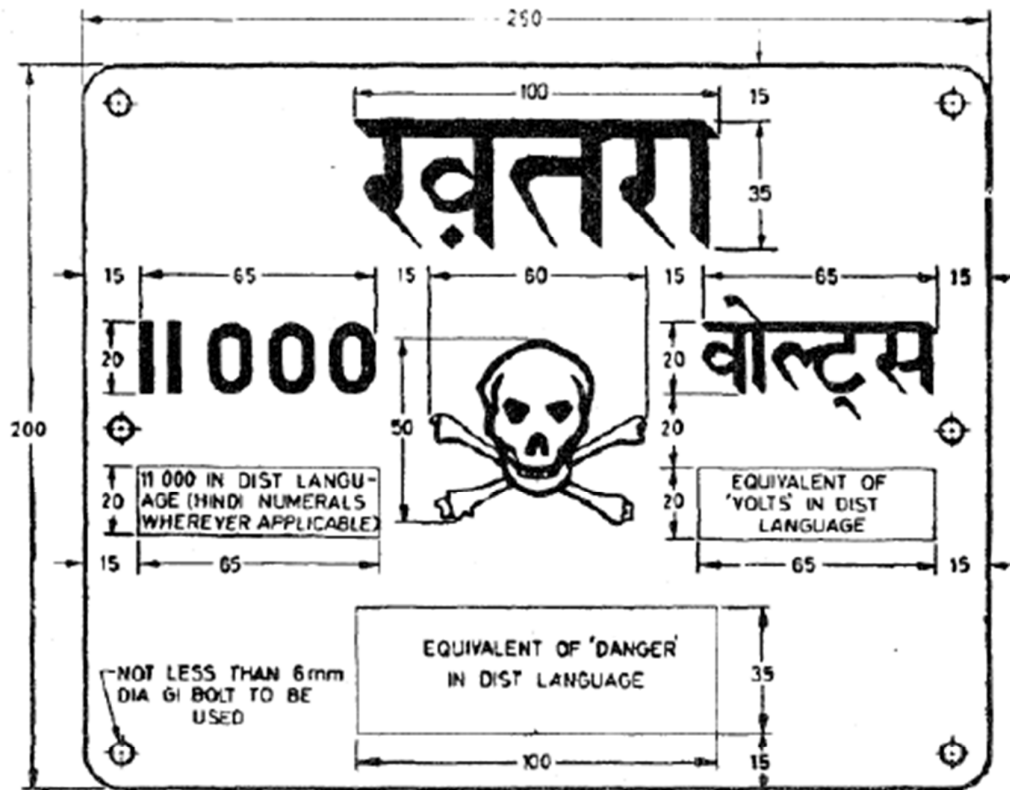

NOTE 1 — All letterings should be centrally spaced.  
NOTE 2 — The dimensions for the words in district language are mainly for guidance, however, care should be taken to space them centrally between the edges and the area of the skull and bones.

NOTE 3 — The location of the fixing holes shall be left to the choice of the user.  
NOTE 4 — 11 000 volts is just specimen, actual voltage is to be inserted for different system voltages.  
NOTE 5 — The corners of the plates should be rounded off.

All dimensions in millimetres.

Rev No.	Description	Prepared By & Date	Checked By & Date	Approved for Issue By & Date
R0	Specifications for DANGER BOARD	Sayantani Das 05/08/2020	Niranjan Khuntia 05/08/2020	Pourush Garg 05/08/2020

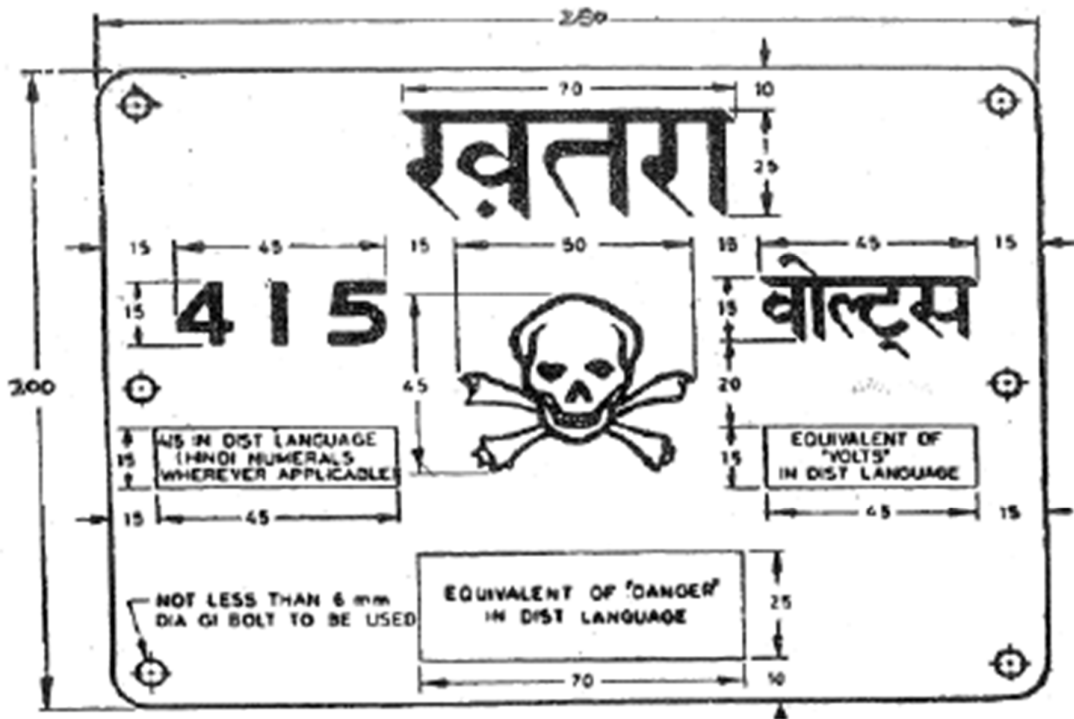

NOTE 1 — All letterings should be centrally spaced.

NOTE 2 — The dimensions for the words in district language are mainly for guidance, however, care should be taken to space them centrally between the edges and the area of the skull and bones.

NOTE 3 — The location of the fixing holes shall be left to the choice of the user.

NOTE 4 — The corners of the plates should be rounded off.

All dimensions in millimetres.

Sample pics of danger boards



Rev No.	Description	Prepared By & Date	Checked By & Date	Approved for Issue By & Date
R0	Specifications for DANGER BOARD	Sayantani Das	Niranjan Khuntia	Pourush Garg
		05/08/2020	05/08/2020	05/08/2020



Rev No.	Description	Prepared By & Date	Checked By & Date	Approved for Issue By & Date
R0	Specifications for DANGER BOARD	Sayantani Das	Niranjan Khuntia	Pourush Garg
		05/08/2020	05/08/2020	05/08/2020



<b>TP Central Odisha Distribution Limited</b>	 TP CENTRAL ODISHA DISTRIBUTION LIMITED	<b>SPECIFICATION FOR TOP BRACKET</b>
<b>NEG-SPEC-07</b>		<b>Date of Issue: 05/08/2020</b>

**Technical Specification  
For  
STAY INSULATOR**

**TP Central Odisha Distribution Limited.  
Network Engineering Group  
2<sup>nd</sup> Floor, IDCO Tower  
Janpath, Bhubaneswar- 751022**

Rev No.	Description	Prepared By & Date	Checked By & Date	Approved for Issue By & Date
R0	Specifications for STAY INSULATOR	Sayantani Das	Niranjana Khuntia	Pourush Garg
		05/08/2020	05/08/2020	05/08/2020

<b>TP Central Odisha Distribution Limited</b>	 TP CENTRAL ODISHA DISTRIBUTION LIMITED	<b>SPECIFICATION FOR TOP BRACKET</b>
<b>NEG-SPEC-07</b>		<b>Date of Issue: 05/08/2020</b>

**CONTENTS**

1. **SCOPE**
2. **APPLICABLE STANDARDS**
3. **CLIMATIC CONDITIONS OF THE INSTALLATION**
4. **GENERAL CONSTRUCTIONS**
5. **GENERAL TECHNICAL REQUIREMENTS**
6. **MARKING**
7. **TESTS**
8. **TYPE TEST CERTIFICATES**
9. **PRE-DESPATCH INSPECTION**
10. **INSPECTION AFTER RECEIPT AT STORES**
11. **GUARANTEE**
12. **PACKING**
13. **TENDER SAMPLE**
14. **QUALITY CONTROL**
15. **MINIMUM TESTING FACILITIES**
16. **MANUFACTURING ACTIVITIES**
17. **SPARES, ACCESSORIES AND TOOLS**
18. **DRAWINGS**
19. **SCHEDULE OF DEVIATIONS**

Rev No.	Description	Prepared By & Date	Checked By & Date	Approved for Issue By & Date
R0	Specifications for STAY INSULATOR	Sayantani Das	Niranjan Khuntia	Pourush Garg
		05/08/2020	05/08/2020	05/08/2020

<b>TP Central Odisha Distribution Limited</b>	 TP CENTRAL ODISHA DISTRIBUTION LIMITED	<b>SPECIFICATION FOR TOP BRACKET</b>
<b>NEG-SPEC-07</b>		<b>Date of Issue: 05/08/2020</b>

## **TECHNICAL SPECIFICATION OF LT & HT GUY STRAIN INSULATORS (STAY INSULATORS)**

### **1. SCOPE:**

The specification covers porcelain guy strain insulators for use in LT & HT distribution system.

### **2. APPLICABLE STANDARDS:**

Except when they conflict with the specific requirements of this specification, the insulators shall comply with IS: 5300-1969 or the latest version thereof.

### **3. GENERAL REQUIREMENTS:**

The porcelain shall be sound, free from defects, thoroughly vitrified and smoothly glazed. The design of the insulators shall be such that the stresses due to expansion and contraction in any part of the insulator shall not lead to its deterioration. The glaze shall be brown in color for insulators. The glaze shall cover the entire porcelain surface parts except those areas that serve as supports during firing.

### **4. SYSTEM CONDITIONS:**

	<b>LT</b>	<b>HT</b>
Frequency	: 50 Hz	50 Hz
Nominal System Voltage	: 400/230 V	11 KV
Maximum System Voltage LT System	: 440/250 V	12KV
Minimum LT Voltage	: 370 V	11 KV
Power frequency one minute withstand (Dry)	: 18 KV	27KV
Power frequency one minute withstand (Dry)	: 8 KV	13KV
Neutral Earthing arrangement LT System	: Solidly Earthed Solidly Earthed	

### **5. TYPE OF INSULATORS:**

The standard guy strain insulators shall be of designation „A“ and „C“ as per IS: 5300/1969 or its latest revision. The recommended type of guy strain insulators for use on guy wires of LT overhead lines are Type-A & 11KV overhead line are Type-C

Rev No.	Description	Prepared By & Date	Checked By & Date	Approved for Issue By & Date
R0	Specifications for STAY INSULATOR	Sayantani Das	Niranjan Khuntia	Pourush Garg
		05/08/2020	05/08/2020	05/08/2020



<b>TP Central Odisha Distribution Limited</b>	 TP CENTRAL ODISHA DISTRIBUTION LIMITED	<b>SPECIFICATION FOR TOP BRACKET</b>
<b>NEG-SPEC-07</b>		<b>Date of Issue: 05/08/2020</b>

## 6. TESTS:

### a. Type tests:

- a) Visual examination
- b) Verification of dimensions
- c) Temperature cycle test
- d) Dry one minute power frequency withstand test
- e) Wet one minute power frequency withstand test
- f) Mechanical strength test
- g) Porosity test

### 6.2 Acceptance test:

The insulators, after having withstood the routine test shall be subjected to the following acceptance tests in the order given below:

- a) Verification of Dimensions.
- b) Temperature cycle test
- c) Mechanical strength test
- d) Porosity test

### 6.3 Routine tests:

- i) Visual examination

Rev No.	Description	Prepared By & Date	Checked By & Date	Approved for Issue By & Date
R0	Specifications for STAY INSULATOR	Sayantani Das	Niranjana Khuntia	Pourush Garg
		05/08/2020	05/08/2020	05/08/2020

<b>TP Central Odisha Distribution Limited</b>	<b>TPCODL</b>  TP CENTRAL ODISHA DISTRIBUTION LIMITED	<b>SPECIFICATION FOR TOP BRACKET</b>
<b>NEG-SPEC-07</b>		<b>Date of Issue: 05/08/2020</b>

## 7. TESTING FACILITIES:

a. The Bidder must clearly indicate what testing facilities are available in the works of the manufacturer and whether the facilities, are adequate to carry out all the routine as well as type tests. These facilities should be made available to Purchaser's Engineers if deputed to carry out or witness the tests. If any tests cannot be carried out at the manufacturer's works, the reasons should be clearly stated in the tender.

b. The Bidder shall furnish detailed type test reports of the offered L.T. & HT Stay Insulators as per clause 6.1 of this specification. All the above Type Tests shall be carried out at laboratories, which are accredited, by the National Accreditation Board of Testing and Calibration Laboratories (NABL) of Government of India to prove that the insulators offered meet the requirements of the specification. These Type Tests should have been carried out within five years prior to the date of opening of this tender.

c. The offered L.T. & HT Stay Insulators are already fully Type Tested at Laboratories accredited by the National Accreditation Board of Testing and Calibration Laboratories (NABL) within five years prior to the date of opening of the tender. There is no change in the design of Type tested L.T. Stay Insulators and those offers against this tender.

### **& Drawings :**

The tender shall be accompanied with the detailed drawings showing the dimensions of the individual insulator, giving all the design dimensions of various component parts. Generally it shall be as per IS.

Rev No.	Description	Prepared By & Date	Checked By & Date	Approved for Issue By & Date
R0	Specifications for STAY INSULATOR	Sayantani Das	Niranjan Khuntia	Pourush Garg
		05/08/2020	05/08/2020	05/08/2020

<b>TP Central Odisha Distribution Limited</b>	<b>TPCODL</b> <small>TP CENTRAL ODISHA DISTRIBUTION LIMITED</small>	<b>SPECIFICATION FOR TOP BRACKET</b>
<b>NEG-SPEC-07</b>		<b>Date of Issue: 05/08/2020</b>

**9. MARKING:**

- a. Each insulator shall be legibly and indelibly marked to show the following:
- i) Name of the Purchaser : „NESCO“
  - ii) Name or trade mark of the manufacturer
  - iii) Year of manufacturer
  - iv) ISI certificate, mark, if any.
- b. Marking on porcelain shall be applied before firing.

**10. Packing :**

All insulators shall be packed in crates or boxes suitable for rough handling. Packing shall be marked with the strength and voltage rating.

Rev No.	Description	Prepared By & Date	Checked By & Date	Approved for Issue By & Date
R0	Specifications for STAY INSULATOR	Sayantani Das	Niranjan Khuntia	Pourush Garg
		05/08/2020	05/08/2020	05/08/2020

<b>TP Central Odisha Distribution Limited</b>	 <b>TPCODL</b> <small>TP CENTRAL ODISHA DISTRIBUTION LIMITED</small>	<b>SPECIFICATION FOR TOP BRACKET</b>
<b>NEG-SPEC-07</b>		<b>Date of Issue: 05/08/2020</b>

**GUARANTEED TECHNICAL PARTICULARS FOR LT GUY STRAIN INSULATOR (TYPE A)**

<b>Sl. No.</b>	<b>Requirement</b>	<b>Requirement</b>	<b>Bidder's offer</b>
1	Name of Manufacturer. & Address	To be specified by the bidder	
2	Location of type testing	To be specified by the bidder	
3	Applicable standard	IS: 5300-1969 or the latest version thereof	
4	Nominal System Voltage	400/230 V	
5	Highest System voltage	440/250 V	
6	Length	90 mm	
7	Diameter	65 mm	
8	Cable hole diameter	16 ± 1.5	
9	1min. power frequency withstand Voltage (Dry)	18 KV (rms)	
10	1min. power frequency withstand Voltage (Wet)	8 KV	
11	Minimum failing load	44 KN	
12	Minimum creepage distance	41 mm	
13	Drawing	To be submitted by bidder	
14	Conforming standard	As per IS	

**NB- Every insulator should bear the marking of manufacturer's name & Purchaser's name and ISI mark**

**Name & Signature of Bidder with seal**

<b>TP Central Odisha Distribution Limited</b>	 <b>TPCODL</b> <small>TP CENTRAL ODISHA DISTRIBUTION LIMITED</small>	<b>SPECIFICATION FOR TOP BRACKET</b>
<b>NEG-SPEC-07</b>		<b>Date of Issue: 05/08/2020</b>

**GUARANTEED TECHNICAL PARTICULARS FOR 11 KV GUY STRAIN INSULATOR (TYPE C)**

Sl. No.	Requirement	Requirement	Bidder's offer
1	Name of Manufacturer. & Address	To be specified by the bidder	
2	Location of type testing	To be specified by the bidder	
3	Applicable standard	IS: 5300-1969 or the latest version thereof	
4	Nominal System Voltage	11 KV	
5	Highest System voltage	12 KV	
6	Length	140 mm	
7	Diameter	85mm	
8	Cable hole diameter	25 ± 1.5	
9	1min. power frequency withstand Voltage (Dry)	27 KV (rms)	
10	1min. power frequency withstand Voltage (Wet)	13 KV	
11	Minimum failing load	88 KN	
12	Minimum creepage distance	57 mm	
13	Drawing	To be submitted by bidder	
14	Conforming standard	As per IS	

**NB- Every insulator should bear the marking of manufacturer's name & Purchaser's name and ISI mar**

**Name & Signature of Bidder with seal**

<b>TP Central Odisha Distribution Limited</b>	 TP CENTRAL ODISHA DISTRIBUTION LIMITED	<b>SPECIFICATION FOR STAY SET ARRANGMRNT</b>
<b>NEG-SPEC-06</b>		<b>Date of Issue: 05/08/2020</b>

**Technical Specification  
For  
STAY ARRANGEMENT(HT & LT)**

**TP Central Odisha Distribution Limited.  
Network Engineering Group  
2<sup>nd</sup> Floor, IDCO Tower  
Janpath, Bhubaneswar- 751022**

Rev No.	Description	Prepared By & Date	Checked By & Date	Approved for Issue By & Date
R0	Specifications for Stay set arrangement	Sayantani Das	Niranjan Khuntia	Pourush Garg
		05/08/2020	05/08/2020	05/08/2020

<b>TP Central Odisha Distribution Limited</b>	 TP CENTRAL ODISHA DISTRIBUTION LIMITED	<b>SPECIFICATION FOR STAY SET ARRANGMRNT</b>
<b>NEG-SPEC-06</b>		<b>Date of Issue: 05/08/2020</b>

## **HT STAY SET ARRANGEMENT**

### **CONTENTS**

1. SCOPE
2. APPLICABLE STANDARDS
3. CLIMATIC CONDITIONS OF THE INSTALLATION
4. GENERAL TECHNICAL REQUIREMENTS
5. GENERAL CONSTRUCTIONS
6. MARKING
7. TESTS
8. TYPE TEST CERTIFICATES
9. PRE-DISPATCH INSPECTION
10. INSPECTION AFTER RECEIPT AT STORES
11. GUARANTEE
12. PACKING
13. TENDER SAMPLE
14. QUALITY CONTROL
15. MINIMUM TESTING FACILITIES
16. MANUFACTURING ACTIVITIES
17. SPARES, ACCESSORIES AND TOOLS
18. DRAWINGS AND DOCUMENTS
19. GUARANTEED TECHNICAL PARTICULARS
20. SCHEDULE OF DEVIATIONS

Rev No.	Description	Prepared By & Date	Checked By & Date	Approved for Issue By & Date
R0	Specifications for Stay set arrangement	Sayantani Das	Niranjan Khuntia	Pourush Garg
		05/08/2020	05/08/2020	05/08/2020

<b>TP Central Odisha Distribution Limited</b>	 <b>TPCODL</b> TP CENTRAL ODISHA DISTRIBUTION LIMITED	<b>SPECIFICATION FOR STAY SET ARRANGMRNT</b>
<b>NEG-SPEC-06</b>		<b>Date of Issue: 05/08/2020</b>

### 1. SCOPE

This specification covers the technical requirements of design, manufacture, test at manufacturer's works, packing & forwarding, supply and unloading at stores/ site and performance of HT Stay Set.

### 2. APPLICABLE STANDARDS

The equipment covered by this specification shall unless otherwise stated, be designed, manufactured and tested in accordance with the latest editions of the following Indian, International Standards and shall conform to the regulations of the local authorities:

Ref IS	Description
IS 4579 -96	Hot Dip Galvanizing For Fabrication
IS 1852 – 85	Tolerance For Raw Material
IS 1367part (13) - 1983	Hot Dip Galvanizing For Tension Screw
IS 2062	Manufactured from raw material as per IS 2062 grade E-250 quality 'A'

### 3. CLIMATIC CONDITIONS OF THE INSTALLATION:

The service conditions shall be as follows:

1. Maximum altitude above sea level 1,000m
2. Maximum ambient air temperature 50°C
3. Maximum daily average ambient air temperature 35°C
4. Minimum ambient air temperature 0°C
5. Maximum relative humidity 95%
6. Average number of thunderstorm days per annum (isokeraunic level) 70
7. Average number of rainy days per annum 120
8. Average annual rainfall 150cm
9. Earthquakes of an intensity in horizontal direction - equivalent to seismic acceleration of 0.3g
10. Earthquakes of an intensity in vertical direction - equivalent to seismic acceleration of 0.15g (g being acceleration due to gravity)
- 11 .Wind velocity: 300 km/hr, 200 km/hr and 160 km/hr.

Environmentally, some of the regions, where the work will take place includes coastal areas, subject to high relative humidity, which can give rise to condensation. Onshore winds will frequently be salt laden. On occasions, the combination of salt and condensation may create pollution conditions for outdoor insulators. Some places are in heavily industrial polluted areas.

Therefore, Outdoor material and equipment shall be designed and protected for use in exposed, heavily polluted, salty, corrosive and humid coastal atmosphere

The design of equipment and accessories shall be suitable to withstand seismic forces corresponding to an acceleration of 0.1 g.

### 4. GENERAL TECHNICAL REQUIREMENTS

S No	Description	Units	Requirement	Tolerance
1.	Material		Manufactured from raw material as per IS 2062 grade E-250 quality 'A'	
2.	Anchor Rod	mm		
a	Nominal Diameter of rod	mm	20 mm diameter	(+/-) 0.5 mm
b	Length of rod	mm	1800 mm	(+/-) 0.5 %
3.	RCC Base Plate		Mix of concrete 1:2:4	
a	Dimension [L x B x Thickness]	mm	450 mm x 450 mm x 75 mm	(+/-) 5 mm
b	Rectangular opening at center	mm	25 mm x 75 mm	(+/-) 0.5 mm
4.	Tension Screw			

Rev No.	Description	Prepared By & Date	Checked By & Date	Approved for Issue By & Date
R0	Specifications for Stay set arrangement	Sayantani Das	Niranjan Khuntia	Pourush Garg
		05/08/2020	05/08/2020	05/08/2020



<b>TP Central Odisha Distribution Limited</b>	 TP CENTRAL ODISHA DISTRIBUTION LIMITED	<b>SPECIFICATION FOR STAY SET ARRANGMRNT</b>
<b>NEG-SPEC-06</b>		<b>Date of Issue: 05/08/2020</b>

a	Eye Bolt	mm	2 No. with 16 mm dia; inner diameter of rounded part of screw 40 mm.	(+/-) 0.5 mm
b	Length of the central part	mm	310 mm	(±) 5 mm
c	Total length after full tightening of both screw / Eye bolt	mm	450 mm	
d	Total length after full opening of both screw / Eye bolt	mm	665 mm	
5.	MS Angle	mm	50 mm x 50 mm x 6 mm; Long 250 mm	(+/-) 0.5 mm; in length (±) 5 mm
6.	Stay Collar	mm	All dimensions as mentioned in drawing.	(+/-) 5 mm

## 5. GENERAL CONSTRUCTIONS

### 5.1 ANCHOR ROD WITH MS ANGLE

Overall length of rod should be 1800 mm to be made out of 20 mm diameter MS rod. One end of rod to be made into a round eye having an inner diameter of 24 mm and outer dia 64 mm with best quality welding. Other end fitted with MS Angle 50 mm x 50 mm x 6 mm; 250 mm long. Hot Dip galvanized as per IS 4759-1996. Details are indicated in the drawing.

### 5.2 RCC BASE PLATE

All material shall be of RCC. With concrete ratio 1:2:4 And 6 no's of 8 mm TMT bar bothways shall be used for reinforcement. Reinforcement bars cross point be welded or perfectly tied up with soft wire. Constructional details and dimension as mentioned in the drawing.

### 5.3 TENSION SCREW

Two no. of eye bolt to be made of 20 mm dia MS Rod having an overall length of 250 mm. One end of the rod to be threaded up to 185 mm length. The other end of the rod shall be rounded into a circular eye of 24 mm inner dia with proper and good quality welding. Tension screw central part shall be one piece forging with total width 310 mm. Tension screw being a threaded fastener be hot dip galvanized as per relevant IS : 1367 (part 13) – 1983. And all other constructional details & dimensions as mentioned in drawing.

### 5.4 STAY COLLAR

To be made of 50 x 6 MS plate and hot dip galvanized as per IS 4759 and all other constructional details & dimensions as mentioned in drawing.

## 6. MARKING

The HT Stay Set shall carry the following information contained in a label attached to it :

- Reference to the Standards.
- Manufacturer's name
- Year of manufacture.
- The following shall be embossed on the HT Stay Set, " PROPERTY OF TPCL,BHUBANESWAR"

## 7. TESTS

All routine, acceptance & type tests shall be carried out in accordance with the relevant IS/IEC. All Routine/acceptance tests shall be witnessed by the purchaser/his authorized representative. All the components shall also be type tested as per the relevant standards. Following tests shall be necessarily conducted on the HT Stay Set in additions to others specified in the IS/IEC/SANS Standards.

Rev No.	Description	Prepared By & Date	Checked By & Date	Approved for Issue By & Date
R0	Specifications for Stay set arrangement	Sayantani Das	Niranjan Khuntia	Pourush Garg
		05/08/2020	05/08/2020	05/08/2020

<b>TP Central Odisha Distribution Limited</b>	 TP CENTRAL ODISHA DISTRIBUTION LIMITED	<b>SPECIFICATION FOR STAY SET ARRANGMRNT</b>
<b>NEG-SPEC-06</b>		<b>Date of Issue: 05/08/2020</b>

**Following tests shall be applicable.**

- 1) Visual examination, Verification of dimension and marking test.
- 2) Tensile Strength.
- 3) Galvanization (Uniformity) test.
- 4) Cube test/ Compression test

**8. TYPE TEST CERTIFICATES**

The bidder shall furnish the type test certificates of the HT Stay Set for the tests as mentioned as above as per the corresponding standards. All the tests shall be conducted by CPRI/ERDA/Other NABL accredited Laboratory as per the relevant standards. Type test should have been conducted in certified Test Laboratories during the period not exceeding 5 years from the date of opening the bid. In the event of any discrepancy in the test reports i.e. any test report not acceptable or any/all type tests (including additional type tests, if any) not carried out, same shall be carried out without any cost implication to TPCL.

**9. PRE DISPATCH INSPECTION**

The Material shall be subject to inspection by a duly authorized representative of the TPCL. Inspection may be made at any stage of manufacture at the discretion of the purchaser and the equipment, if found unsatisfactory as to workmanship or material, the same is liable to rejection. Bidder shall grant free access to the places of manufacture to TPCL's representatives at all times when the work is in progress. Inspection by the TPCL or its authorized representatives shall not relieve the bidder of his obligation of furnishing equipment in accordance with the specifications. Material shall be dispatched after specific MDCC (Material Dispatch Clearance Certificate) is issued by TPCL.

Following documents shall be sent along with material

- a) Test reports
- b) MDCC issued by TPCL
- c) Invoice in duplicate
- d) Packing list
- e) Drawings & catalogue
- f) Guarantee / Warrantee card
- g) Delivery Challan
- h) Other Documents (as applicable).

**10. INSPECTION AFTER RECEIPT AT STORES**

The material received at TPCL, Bhubaneswar, Odisha store will be inspected for acceptance and shall be liable for rejection, if found different from the reports of the pre-dispatch inspection and one copy of the report shall be sent to Project Engineering department.

**11. GUARANTEE**

Bidder shall stand guarantee towards design, materials, workmanship & quality of process/ manufacturing of items under this contract for due and intended performance of the same, as an integrated product delivered under this contract. In the event any defect is found by the Purchaser up to a period of at least 12 months from the date of commissioning or 24 months from the date of last supplies made under the contract whichever is later, (the time scale of 12/24 months could be enhanced subject to mutual agreements). Bidder shall be liable to undertake to replace/rectify such defects at its own costs, within mutually agreed time frame, and to the entire satisfaction of the Purchaser, failing which the Purchaser will be at liberty to get it replaced/rectified at Bidder's risks and costs and recover all such expenses plus the Purchaser's own charges (@ 20% of expenses incurred), from the Bidder or from the "Security cum Performance Deposit" as the case may be.

Bidder shall further be responsible for 'free replacement' for another period of THREE years from the end of the guarantee period for any 'Latent Defects' if noticed and reported by the Purchaser.

Rev No.	Description	Prepared By & Date	Checked By & Date	Approved for Issue By & Date
R0	Specifications for Stay set arrangement	Sayantani Das	Niranjan Khuntia	Pourush Garg
		05/08/2020	05/08/2020	05/08/2020

<b>TP Central Odisha Distribution Limited</b>	 TP CENTRAL ODISHA DISTRIBUTION LIMITED	<b>SPECIFICATION FOR STAY SET ARRANGMRNT</b>
<b>NEG-SPEC-06</b>		<b>Date of Issue: 05/08/2020</b>

## 12. PACKING

Supplier shall ensure that all the equipment covered under this specification shall be prepared for rail/road transport and be packed in such a manner so as to protect the equipment from damage in transit. The material used for packing shall be environmentally friendly.

## 13. TENDER SAMPLE

Bidder shall submit the sample of material with the offer (in case of first supply to TPCL).

## 14. QUALITY CONTROL

The bidder shall submit with the offer Quality assurance plan indicating the various stages of inspection, the tests and checks which will be carried out on the material of construction, components during manufacture and bought out items and fully assembled component and equipment after finishing. As part of the plan, a schedule for stage and final inspection within the parameters of the delivery schedule shall be furnished. The Purchaser's engineer or its nominated representative shall have free access to the manufacturer's/sub-supplier's works to carry out inspections. The bidder shall ensure that the material supplied is as per the Guaranteed Technical Particulars as specified in the specifications.

## 15. MINIMUM TESTING FACILITIES

Bidder shall have adequate in house testing facilities for carrying out all routine tests & acceptance tests as per relevant International / Indian standards.

## 16. MANUFACTURING ACTIVITIES

The successful bidder will have to submit the bar chart for various manufacturing activities clearly elaborating each stage, with quantity. This bar chart should be in line with the Quality assurance plan submitted with the offer. This bar chart will have to be submitted within 15 days from the release of the order.

## 17. SPARES, ACCESSORIES AND TOOLS

Not applicable

## 18. DRAWINGS AND DOCUMENTS

Following documents shall be prepared based on TPCL specifications and statutory requirements with complete BOM and shall be submitted with the bid:

- Completely filled in Technical Particulars.
- General description of the equipment and all components including brochures.
- Type test Certificates
- Experience List.

After the after of the contract, four (4) copies of the drawings, drawn to scale, describing the equipment in detail shall be forwarded for approval and shall subsequently provide four (4) complete sets of final drawings, one of which shall be auto positive suitable for reproduction, before the dispatch of the equipment. Soft copy (Compact Disk CD) of all the drawing, GTP, test certificates shall be submitted after the final approval of the same to the purchaser

Rev No.	Description	Prepared By & Date	Checked By & Date	Approved for Issue By & Date
R0	Specifications for Stay set arrangement	Sayantani Das	Niranjan Khuntia	Pourush Garg
		05/08/2020	05/08/2020	05/08/2020

Following Drawings/Documents shall be submitted after the award of the contract

S. No	Description	For Approval	For Review Information	Final Submission
1	Technical Parameters	√		√
2	Manual/Catalogues/drawings for all components.		√	
3	Technical details and test certificates.		√	√
4	Installation Instructions		√	√
5	Transport/shipping dimension drawing		√	√
6	QA & QC Plan	√	√	√
7	Routine, Acceptance and Type test Certificates	√	√	√

All the Documents and Drawings shall be in English Language.

**Instruction Manuals:** Bidder shall furnish two (2) soft copies (CD) and four (4) hard copies of nicely bound manual (in English Language) covering erection and maintenance instructions and all relevant information pertaining to the main equipment as well as auxiliary devices.

Rev No.	Description	Prepared By & Date	Checked By & Date	Approved for Issue By & Date
R0	Specifications for Stay set arrangement	Sayantani Das	Niranjan Khuntia	Pourush Garg
		05/08/2020	05/08/2020	05/08/2020

**19. GUARANTEED TECHNICAL PARTICULARS**

S No	Description	Units	To be furnished by bidder	Requirement	
1.	Material				
2.	Anchor Rod	mm			
a	Nominal Diameter of rod	mm			
b	Length of rod	mm			
3.	RCC Base Plate				
a	Dimension [L x B x Thickness]	mm			
b	Rectangular opening at center	mm			
4.	Tension Screw				
a	Eye Bolt	mm			
b	Length of the central part	mm			
c	Total length after full tightening of both screw / Eye bolt	mm			
d	Total length after full opening of both screw / Eye bolt	mm			
5.	MS Angle	mm			
6.	Stay Collar	mm			

Rev No.	Description	Prepared By & Date	Checked By & Date	Approved for Issue By & Date
R0	Specifications for Stay set arrangement	Sayantani Das	Niranjan Khuntia	Pourush Garg
		05/08/2020	05/08/2020	05/08/2020

<b>TP Central Odisha Distribution Limited</b>	 TP CENTRAL ODISHA DISTRIBUTION LIMITED	<b>SPECIFICATION FOR STAY SET ARRANGMRNT</b>
<b>NEG-SPEC-06</b>		<b>Date of Issue: 05/08/2020</b>

20.

SCHEDULE OF DEVIATIONS  
**(TO BE ENCLOSED WITH TECHNICAL BID)**

All deviations from this specification shall be set out by the Bidders, clause by Clause in this schedule. Unless specifically mentioned in this Schedule, the tender shall be deemed to confirm the purchaser's specifications:

S. No	Clause No.	Details of deviation with justifications

We confirm that there are no deviations apart from those detailed above.

Seal of the Company:

Signature

Designation

Rev No.	Description	Prepared By & Date	Checked By & Date	Approved for Issue By & Date
R0	Specifications for Stay set arrangement	Sayantani Das	Niranjan Khuntia	Pourush Garg
		05/08/2020	05/08/2020	05/08/2020

<b>TP Central Odisha Distribution Limited</b>	 TP CENTRAL ODISHA DISTRIBUTION LIMITED	<b>SPECIFICATION FOR STAY SET ARRANGMRNT</b>
<b>NEG-SPEC-06</b>		<b>Date of Issue: 05/08/2020</b>

## LT STAY SET ARRAGEMENT

### CONTENTS

1. SCOPE
2. APPLICABLE STANDARDS
3. CLIMATIC CONDITIONS OF THE INSTALLATION
4. GENERAL TECHNICAL REQUIREMENTS
5. GENERAL CONSTRUCTIONS
6. MARKING
7. TESTS
8. TYPE TEST CERTIFICATES
9. PRE-DISPATCH INSPECTION
10. INSPECTION AFTER RECEIPT AT STORES
11. GUARANTEE
12. PACKING
13. TENDER SAMPLE
14. QUALITY CONTROL
15. MINIMUM TESTING FACILITIES
16. MANUFACTURING ACTIVITIES
17. SPARES, ACCESSORIES AND TOOLS
18. DRAWINGS AND DOCUMENTS
19. GUARANTEED TECHNICAL PARTICULARS
20. SCHEDULE OF DEVIATIONS

Rev No.	Description	Prepared By & Date	Checked By & Date	Approved for Issue By & Date
R0	Specifications for Stay set arrangement	Sayantani Das	Niranjan Khuntia	Pourush Garg
		05/08/2020	05/08/2020	05/08/2020

<b>TP Central Odisha Distribution Limited</b>	 TP CENTRAL ODISHA DISTRIBUTION LIMITED	<b>SPECIFICATION FOR STAY SET ARRANGMRNT</b>
<b>NEG-SPEC-06</b>		<b>Date of Issue: 05/08/2020</b>

### 1. SCOPE

This specification covers the technical requirements of design, manufacture, test at manufacturer's works, packing & forwarding, supply and unloading at stores/ site and performance of LT Stay Set.

### 2. APPLICABLE STANDARDS

The equipment covered by this specification shall unless otherwise stated, be designed, manufactured and tested in accordance with the latest editions of the following Indian, International Standards and shall conform to the regulations of the local authorities:

Ref IS	Discription
IS 4579 -96	Hot Dip Galvanizing For Fabrication
IS 1852 – 85	Tolerance For Raw Material
IS 1367part (13) - 1983	Hot Dip Galvanizing For Tension Screw
IS 2062	Manufactured from raw material as per IS 2062 grade E-250 quality 'A'

### 3. CLIMATIC CONDITIONS OF THE INSTALLATION:

The service conditions shall be as follows:

1. Maximum altitude above sea level 1,000m
2. Maximum ambient air temperature 50°C
3. Maximum daily average ambient air temperature 35°C
4. Minimum ambient air temperature 0°C
5. Maximum relative humidity 95%
6. Average number of thunderstorm days per annum (isokeraunic level) 70
7. Average number of rainy days per annum 120
8. Average annual rainfall 150cm
9. Earthquakes of an intensity in horizontal direction - equivalent to seismic acceleration of 0.3g
10. Earthquakes of an intensity in vertical direction - equivalent to seismic acceleration of 0.15g (g being acceleration due to gravity)
- 11 .Wind velocity: 300 km/hr, 200 km/hr and 160 km/hr.

Environmentally, some of the regions, where the work will take place includes coastal areas, subject to high relative humidity, which can give rise to condensation. Onshore winds will frequently be salt laden. On occasions, the combination of salt and condensation may create pollution conditions for outdoor insulators. Some places are in heavily industrial polluted areas.

Therefore, Outdoor material and equipment shall be designed and protected for use in exposed, heavily polluted, salty, corrosive and humid coastal atmosphere

The design of equipment and accessories shall be suitable to withstand seismic forces corresponding to an acceleration of 0.1 g.

Rev No.	Description	Prepared By & Date	Checked By & Date	Approved for Issue By & Date
R0	Specifications for Stay set arrangement	Sayantani Das	Niranjan Khuntia	Pourush Garg
		05/08/2020	05/08/2020	05/08/2020



<b>TP Central Odisha Distribution Limited</b>	 <b>TPCODL</b> TP CENTRAL ODISHA DISTRIBUTION LIMITED	<b>SPECIFICATION FOR STAY SET ARRANGMRNT</b>
<b>NEG-SPEC-06</b>		<b>Date of Issue: 05/08/2020</b>

#### 4. GENERAL TECHNICAL REQUIREMENTS

S No	Description	Units	Requirement	Tolerance
1.	Material		Manufactured from raw material as per IS 2062 grade E-250 quality 'A'	
2.	Anchor Rod	mm		
a	Nominal Diameter of rod	mm	16 mm diameter	(+/-) 0.5 mm
b	Length of rod	mm	1800 mm	(+/-) 0.5 %
3.	RCC Base Plate		Mix of concrete 1:2:4	
a	Dimension [L x B x Thickness]	mm	450 mm x 450 mm x 75 mm	(+/-) 5 mm
b	Rectangular opening at center	mm	25 mm x 75 mm	(+/-) 0.5 mm
4.	Tension Screw			
a	Eye Bolt	mm	2 No. with 16 mm dia; inner diameter of rounded part of screw 24 mm.	(+/-) 0.5 mm
b	Length of the central part	mm	310 mm	(+/-) 5 mm
c	Total length after full tightening of both screw / Eye bolt	mm	445 mm	
d	Total length after full opening of both screw / Eye bolt	mm	665 mm	
5.	MS Angle	mm	50 mm x 50 mm x 6 mm; Long 250 mm	(+/-) 0.5 mm ; in length (+/-) 5 mm
6.	Stay Collar	mm	All dimensions as mentioned in drawing.	(+/-) 5 mm

#### 5. GENERAL CONSTRUCTIONS

##### 5.1 ANCHOR ROD WITH MS ANGLE

Overall length of rod should be 1800 mm to be made out of 16 mm diameter GS rod. One end of rod to be made into a round eye having an inner diameter of 24 mm and outer dia 64 mm with best quality welding. Other end fitted with MS Angle 50 mm x 50 mm x 6 mm; 250 mm long. Details are indicated in the drawing.

##### 5.2 RCC BASE PLATE

All material shall be of RCC. With concrete ratio 1:2:4 And 6 nos of 8 mm TOR both ways shall be used. constructional details as mentioned in the drawing.

##### 5.3 TENSION SCREW

Eye bolt to be made of 16 mm dia GS Rod having an overall length of 250 mm. One end of the rod to be threaded up to 185 mm length. The other end of the rod shall be rounded into a circular eye of 24 mm inner dia with proper and good quality welding. Tension screw central part shall be one piece forging with total width 310 mm. Tension screw being a threaded fastener be hot dip galvanized as per relevant IS : 1367 (part 13) – 1983. and all other constructional details as mentioned in drawing.

##### 5.4 STAY COLLAR

To be made of 50 x 6 MS Strip and hot dip galvanized as per IS 4759 and all other constructional details as mentioned in drawing.

Rev No.	Description	Prepared By & Date	Checked By & Date	Approved for Issue By & Date
R0	Specifications for Stay set arrangement	Sayantani Das	Niranjan Khuntia	Pourush Garg
		05/08/2020	05/08/2020	05/08/2020

<b>TP Central Odisha Distribution Limited</b>	 TP CENTRAL ODISHA DISTRIBUTION LIMITED	<b>SPECIFICATION FOR STAY SET ARRANGMRNT</b>
<b>NEG-SPEC-06</b>		<b>Date of Issue: 05/08/2020</b>

## 6. MARKING

The LT Stay Set shall carry the following information contained in a label attached to it :

- e) Reference to the Standards.
- f) Manufacturer's name
- g) Year of manufacture.
- h) The following shall be embossed on the LT Stay Set," PROPERTY OF TPCL,  
BHUBANESWAR."

## 7. TESTS

All routine, acceptance & type tests shall be carried out in accordance with the relevant IS/IEC. All Routine/acceptance tests shall be witnessed by the purchaser/his authorized representative. All the components shall also be type tested as per the relevant standards. Following tests shall be necessarily conducted on the LT Stay Set in additions to others specified in the IS/IEC/SANS Standards.

### Following tests shall be applicable.

- 5) Visual examination, Verification of dimension and marking test.
- 6) Tensile Strength.
- 7) Galvanization (Uniformity) test.
- 8) Cube test/ Compression test

## 8. TYPE TEST CERTIFICATES

The bidder shall furnish the type test certificates of the LT Stay Set for the tests as mentioned as above as per the corresponding standards. All the tests shall be conducted by CPRI/ERDA/Other NABL accredited Laboratory as per the relevant standards. Type test should have been conducted in certified Test Laboratories during the period not exceeding 5 years from the date of opening the bid. In the event of any discrepancy in the test reports i.e. any test report not acceptable or any/all type tests (including additional type tests, if any) not carried out, same shall be carried out without any cost implication to TPCL.

## 9. PRE DISPATCH INSPECTION

The Material shall be subject to inspection by a duly authorized representative of the TPCL. Inspection may be made at any stage of manufacture at the discretion of the purchaser and the equipment, if found unsatisfactory as to workmanship or material, the same is liable to rejection. Bidder shall grant free access to the places of manufacture to TPCL's representatives at all times when the work is in progress. Inspection by the TPCL or its authorized representatives shall not relieve the bidder of his obligation of furnishing equipment in accordance with the specifications. Material shall be dispatched after specific MDCC (Material Dispatch Clearance Certificate) is issued by TPCL.

Following documents shall be sent along with material

- i) Test reports
- j) MDCC issued by TPCL
- k) Invoice in duplicate
- l) Packing list
- m) Drawings & catalogue
- n) Guarantee / Warrantee card
- o) Delivery Challan
- p) Other Documents (as applicable).

Rev No.	Description	Prepared By & Date	Checked By & Date	Approved for Issue By & Date
R0	Specifications for Stay set arrangement	Sayantani Das	Niranjan Khuntia	Pourush Garg
		05/08/2020	05/08/2020	05/08/2020

<b>TP Central Odisha Distribution Limited</b>	 TP CENTRAL ODISHA DISTRIBUTION LIMITED	<b>SPECIFICATION FOR STAY SET ARRANGMRNT</b>
<b>NEG-SPEC-06</b>		<b>Date of Issue: 05/08/2020</b>

#### 10. INSPECTION AFTER RECEIPT AT STORES

The material received at TPCL, Bhubaneswar, Odisha store will be inspected for acceptance and shall be liable for rejection, if found different from the reports of the pre-dispatch inspection and one copy of the report shall be sent to Project Engineering department.

#### 11. GUARANTEE

Bidder shall stand guarantee towards design, materials, workmanship & quality of process/ manufacturing of items under this contract for due and intended performance of the same, as an integrated product delivered under this contract. In the event any defect is found by the Purchaser up to a period of at least 12 months from the date of commissioning or 24 months from the date of last supplies made under the contract whichever is later, (the time scale of 12/24 months could be enhanced subject to mutual agreements). Bidder shall be liable to undertake to replace/rectify such defects at its own costs, within mutually agreed time frame, and to the entire satisfaction of the Purchaser, failing which the Purchaser will be at liberty to get it replaced/rectified at Bidder's risks and costs and recover all such expenses plus the Purchaser's own charges (@ 20% of expenses incurred), from the Bidder or from the "Security cum Performance Deposit" as the case may be.

Bidder shall further be responsible for 'free replacement' for another period of THREE years from the end of the guarantee period for any 'Latent Defects' if noticed and reported by the Purchaser.

#### 12. PACKING

Supplier shall ensure that all the equipment covered under this specification shall be prepared for rail/road transport and be packed in such a manner so as to protect the equipment from damage in transit. The material used for packing shall be environmentally friendly.

#### 13. TENDER SAMPLE

Bidder shall submit the sample of material with the offer (in case of first supply to TPCL).

#### 14. QUALITY CONTROL

The bidder shall submit with the offer Quality assurance plan indicating the various stages of inspection, the tests and checks which will be carried out on the material of construction, components during manufacture and bought out items and fully assembled component and equipment after finishing. As part of the plan, a schedule for stage and final inspection within the parameters of the delivery schedule shall be furnished. The Purchaser's engineer or its nominated representative shall have free access to the manufacturer's/sub-supplier's works to carry out inspections. The bidder shall ensure that the material supplied is as per the Guaranteed Technical Particulars as specified in the specifications.

#### 15. MINIMUM TESTING FACILITIES

Bidder shall have adequate in house testing facilities for carrying out all routine tests & acceptance tests as per relevant International / Indian standards.

#### 16. MANUFACTURING ACTIVITIES

The successful bidder will have to submit the bar chart for various manufacturing activities clearly elaborating each stage, with quantity. This bar chart should be in line with the Quality assurance plan submitted with the offer. This bar chart will have to be submitted within 15 days from the release of the order.

#### 17. SPARES, ACCESSORIES AND TOOLS

Not applicable

Rev No.	Description	Prepared By & Date	Checked By & Date	Approved for Issue By & Date
R0	Specifications for Stay set arrangement	Sayantani Das	Niranjan Khuntia	Pourush Garg
		05/08/2020	05/08/2020	05/08/2020

<b>TP Central Odisha Distribution Limited</b>	 TP CENTRAL ODISHA DISTRIBUTION LIMITED	<b>SPECIFICATION FOR STAY SET ARRANGMRNT</b>
<b>NEG-SPEC-06</b>		<b>Date of Issue: 05/08/2020</b>

### 18. DRAWINGS AND DOCUMENTS

Following documents shall be prepared based on TPCL specifications and statutory requirements with complete BOM and shall be submitted with the bid:

- e) Completely filled in Technical Particulars.
- f) General description of the equipment and all components including brochures.
- g) Type test Certificates
- h) Experience List.

After the contract, four (4) copies of the drawings, drawn to scale, describing the equipment in detail shall be forwarded for approval and shall subsequently provide four (4) complete sets of final drawings, one of which shall be auto positive suitable for reproduction, before the dispatch of the equipment. Soft copy (Compact Disk CD) of all the drawing, GTP, test certificates shall be submitted after the final approval of the same to the purchaser

Following Drawings/Documents shall be submitted after the award of the contract

S. No	Description	For Approval	For Review Information	Final Submission
1	Technical Parameters	√		√
2	Manual/Catalogues/drawings for all components.		√	
3	Technical details and test certificates.		√	√
4	Installation Instructions		√	√
5	Transport/shipping dimension drawing		√	√
6	QA & QC Plan	√	√	√
7	Routine, Acceptance and Type test Certificates	√	√	√

All the Documents and Drawings shall be in English Language.

**Instruction Manuals:** Bidder shall furnish two (2) soft copies (CD) and four (4) hard copies of nicely bound manual (in English Language) covering erection and maintenance instructions and all relevant information pertaining to the main equipment as well as auxiliary devices.

Rev No.	Description	Prepared By & Date	Checked By & Date	Approved for Issue By & Date
R0	Specifications for Stay set arrangement	Sayantani Das	Niranjan Khuntia	Pourush Garg
		05/08/2020	05/08/2020	05/08/2020

**19. GUARANTEED TECHNICAL PARTICULARS**

S No	Description	Units	To be furnished by bidder	Requirement	
1.	Material				
2.	Anchor Rod	mm			
a	Nominal Diameter of rod	mm			
b	Length of rod	mm			
3.	RCC Base Plate				
a	Dimension [L x B x Thickness]	mm			
b	Rectangular opening at center	mm			
4.	Tension Screw				
a	Eye Bolt	mm			
b	Length of the central part	mm			
c	Total length after full tightening of both screw / Eye bolt	mm			
d	Total length after full opening of both screw / Eye bolt	mm			
5.	MS Angle	mm			
6.	Stay Collar	mm			

Rev No.	Description	Prepared By & Date	Checked By & Date	Approved for Issue By & Date
R0	Specifications for Stay set arrangement	Sayantani Das	Niranjan Khuntia	Pourush Garg
		05/08/2020	05/08/2020	05/08/2020

20.

**SCHEDULE OF DEVIATIONS  
(TO BE ENCLOSED WITH TECHNICAL BID)**

All deviations from this specification shall be set out by the Bidders, clause by Clause in this schedule. Unless specifically mentioned in this Schedule, the tender shall be deemed to confirm the purchaser's specifications:

S. No	Clause No.	Details of deviation with justifications

We confirm that there are no deviations apart from those detailed above.

Seal of the Company:

Signature

Designation

Rev No.	Description	Prepared By & Date	Checked By & Date	Approved for Issue By & Date
R0	Specifications for Stay set arrangement	Sayantani Das	Niranjan Khuntia	Pourush Garg
		05/08/2020	05/08/2020	05/08/2020

<b>TP Central Odisha Distribution Limited</b>	<b>TPCODL</b> <small>TP CENTRAL ODISHA DISTRIBUTION LIMITED</small>	<b>Specification for Stay Wire 7/8 SWG</b>
<b>NEG-SPEC-01</b>		<b>Date of Issue: 05/08/2020</b>

**Technical Specification  
For  
SWG STAY WIRE 7/8 SWG**

**TP Central Odisha Distribution Limited.  
Network Engineering Group  
2<sup>nd</sup> Floor, IDCO Tower  
Janpath, Bhubaneswar- 751022**

Rev No.	Description	Prepared By & Date	Checked By & Date	Approved for Issue By & Date
R0	Specifications for SWG STAY WIRE 7/8 SWG	Sayantani Das	Niranjan Khuntia	Pourush Garg
		05/08/2020	05/08/2020	05/08/2020

<b>TP Central Odisha Distribution Limited</b>	<b>TPCODL</b> <small>TP CENTRAL ODISHA DISTRIBUTION LIMITED</small>	<b>Specification for Stay Wire 7/8 SWG</b>
<b>NEG-SPEC-01</b>		<b>Date of Issue: 05/08/2020</b>

## CONTENTS

- 1.0 SCOPE
- 2.0 APPLICABLE STANDARDS
- 3.0 CLIMATIC CONDITIONS OF INSTALLATION
- 4.0 GENERAL TECHNICAL REQUIREMENTS
- 5.0 GENERAL CONSTRUCTIONS
- 6.0 MARKING
- 7.0 TESTS
- 8.0 TYPE TEST CERTIFICATES
- 9.0 PRE-DISPATCH INSPECTION
- 10.0 INSPECTION AFTER RECEIPT AT STORES
- 11.0 GUARANTEE
- 12.0 PACKING
- 13.0 TENDER SAMPLE
- 14.0 QUALITY CONTROL
- 15.0 MINIMUM TESTING FACILITIES
- 16.0 MANUFACTURING ACTIVITIES
- 17.0 SPARES, ACCESSORIES AND TOOLS
- 18.0 DRAWINGS AND DOCUMENTS
- 19.0 GUARANTEED TECHNICAL PARTICULARS
- 20.0 SCHEDULE OF DEVIATIONS

Rev No.	Description	Prepared By & Date	Checked By & Date	Approved for Issue By & Date
R0	Specifications for SWG STAY WIRE 7/8 SWG	Sayantani Das	Niranjan Khuntia	Pourush Garg
		05/08/2020	05/08/2020	05/08/2020



<b>TP Central Odisha Distribution Limited</b>	 <b>TPCODL</b> TP CENTRAL ODISHA DISTRIBUTION LIMITED	<b>Specification for Stay Wire 7/8 SWG</b>
<b>NEG-SPEC-01</b>		<b>Date of Issue: 05/08/2020</b>

## 1.0 SCOPE

This specification covers the technical requirements of design, manufacture, testing at manufacturer's works, packing, forwarding, supply and unloading at site/store and performance of Stay Wire for trouble free and efficient operation.

## 2.0 APPLICABLE STANDARDS

The equipment covered by this specification shall unless otherwise stated, be designed, manufactured and tested in accordance with the latest editions of the following Indian, International standards / IEC and shall conform to the regulations of the local authorities.

- a) IS 2141 : Specification for Hot Dip Galvanized Stay Strand.
- b) IS 4826 : Specification for hot-dipped galvanized coatings on round steel wires.
- c) IS 2633 : Methods for testing uniformity of coating on zinc coated articles.
- d) IS 6745 : Method for determination of mass of zinc coating on zinc coated iron and steel articles.

## 3.0 CLIMATIC CONDITIONS OF THE INSTALLATION:

The material shall be suitable for following climatic conditions,

1. Maximum altitude above sea level 1,000m
2. Maximum ambient air temperature 50°C
3. Maximum daily average ambient air temperature 35°C
4. Minimum ambient air temperature 0°C
5. Maximum relative humidity 95%
6. Average number of thunderstorm days per annum (isokeraunic level) 70
7. Average number of rainy days per annum 120
8. Average annual rainfall 150cm
9. Earthquakes of an intensity in horizontal direction - equivalent to seismic acceleration of 0.3g
10. Earthquakes of an intensity in vertical direction - equivalent to seismic acceleration of 0.15g (g being acceleration due to gravity)
- 11 .Wind velocity: 300 km/hr, 200 km/hr and 160 km/hr.

Environmentally, some of the regions, where the work will take place includes coastal areas, subject to high relative humidity, which can give rise to condensation. Onshore winds will frequently be salt laden. On occasions, the combination of salt and condensation may create pollution conditions for outdoor insulators. Some places are in heavily industrial polluted areas. Therefore, Outdoor material and equipment shall be designed and protected for use in exposed, heavily polluted, salty, corrosive and humid coastal atmosphere. The design of equipment and accessories shall be suitable to withstand seismic forces corresponding to an acceleration of 0.1 g.

Rev No.	Description	Prepared By & Date	Checked By & Date	Approved for Issue By & Date
R0	Specifications for SWG STAY WIRE 7/8 SWG	Sayantani Das	Niranjan Khuntia	Pourush Garg
		05/08/2020	05/08/2020	05/08/2020

<b>TP Central Odisha Distribution Limited</b>	 <b>TPCODL</b> <small>TP CENTRAL ODISHA DISTRIBUTION LIMITED</small>	<b>Specification for Stay Wire 7/8 SWG</b>
<b>NEG-SPEC-01</b>		<b>Date of Issue: 05/08/2020</b>

#### 4.0 GENERAL TECHNICAL REQUIREMENTS

Sl. No.	Technical Parameter	Unit	Requirement
<b>1</b>	Size of Wire mm		Stay Wire 7/8 SWG
	Standard	<b>mm</b>	4 mm
	<b>Min</b>	<b>mm</b>	3.97 mm
	<b>Max</b>	<b>mm</b>	4.06 mm
<b>2</b>	Diameter of Strand	<b>mm</b>	<b>12mm</b>
<b>3</b>	Min breaking force of strand	<b>kN</b>	54.9 kN
<b>4</b>	Min Tensile strength of single wire before stranding	<b>kN</b>	<b>8.8kN</b>
<b>5</b>	Lay ratio		12-18 times of strand dia
<b>6</b>	Weight of Zn coating after strand		275 gms/meter <sup>2</sup>
<b>7</b>	No of dips (Uniformity of Zn coating) before Strand		3 dips of one minute
	After strand		2 dips of one minute & 1 dip of ½ minute
<b>8</b>	Adhesion of Zn coating		10 complete turns
<b>9</b>	Min Elongation %	<b>%</b>	6%

#### 5.0 GENERAL CONSTRUCTION

All material shall be as per IS: 2141. Uniform Zinc coating on hot dip galvanized wire to be done as per IS: 4826 for protection from rust. All finished wires shall be well and cleanly drawn to the dimensions specified. The wire shall be sound, free from splits, surface flaws, rough jagged and imperfect edges and other harmful surface defects.

#### 6.0 MARKING

Each coil of wire shall be marked legibly with the finish, size of wire, lot number and year of manufacture. And the unit shall be marked as "PROPERTY OF TPCL, BHUBANESWAR".

Rev No.	Description	Prepared By & Date	Checked By & Date	Approved for Issue By & Date
R0	Specifications for SWG STAY WIRE 7/8 SWG	Sayantani Das	Niranjan Khuntia	Pourush Garg
		05/08/2020	05/08/2020	05/08/2020

<b>TP Central Odisha Distribution Limited</b>	 <b>TPCODL</b> TP CENTRAL ODISHA DISTRIBUTION LIMITED	<b>Specification for Stay Wire 7/8 SWG</b>
<b>NEG-SPEC-01</b>		<b>Date of Issue: 05/08/2020</b>

## 7.0 TESTS

All routine, acceptance and type tests of Stay Wire shall be carried out in accordance with the relevant IS 2141 standards. All routine/acceptance tests shall be witnessed by the Purchaser/his authorized representative. Following tests shall be necessarily conducted on the Stay Wire as specified in IS standards.

### TYPE TESTS

- a) Diameter of the wire.
- b) Chemical composition test.
- c) Breaking load of complete strand.
- d) Wrapping test of the wire.
- e) Lay Ratio.
- f) Mass of zinc coating.
- g) Uniformity of zinc coating.
- h) Adhesion of zinc coating.
- i) Elongation test

### ACCEPTANCE TESTS

- a) Diameter of the wire.
- b) Overall diameter of the strand.
- c) Chemical composition test.
- d) Breaking load of complete strand.
- e) Wrapping test of the wire.
- f) Lay Ratio.
- g) Mass of zinc coating.
- h) Uniformity of zinc coating.
- i) Adhesion of zinc coating.
- j) Elongation test

### ROUTINE TESTS

- a. Diameter of the wire.
- b. Overall diameter of the strand.
- c. Chemical composition test.
- d. Breaking load of complete strand.
- e. Wrapping test of the wire.
- f. Lay Ratio.
- g. Mass of zinc coating.
- h. Uniformity of zinc coating.
- i. Adhesion of zinc coating.
- j. Elongation test

## 8.0 TYPE TEST CERTIFICATES

The bidder shall furnish the type test certificates of the Stay Wire for the tests as mentioned as above as per the corresponding standards. All the tests shall be conducted by CPRI, ERDA or from any NABL accredited laboratory as per the relevant standards. Type test should have been conducted in certified Test Laboratories during the period not exceeding 5 years from the date of opening the bid. In the event of any discrepancy in the test reports i.e. any test report not acceptable or any/all type tests (including additional type tests, if any) not carried out, same shall be carried out without any cost implication to TPCL.

Rev No.	Description	Prepared By & Date	Checked By & Date	Approved for Issue By & Date
R0	Specifications for SWG STAY WIRE 7/8 SWG	Sayantani Das	Niranjan Khuntia	Pourush Garg
		05/08/2020	05/08/2020	05/08/2020

<b>TP Central Odisha Distribution Limited</b>	 <b>TPCODL</b> TP CENTRAL ODISHA DISTRIBUTION LIMITED	<b>Specification for Stay Wire 7/8 SWG</b>
<b>NEG-SPEC-01</b>		<b>Date of Issue: 05/08/2020</b>

### 9.0 PRE DISPATCH INSPECTION

The Material shall be subject to inspection by a duly authorized representative of the TPCL. Inspection may be made at any stage of manufacture at the discretion of the purchaser and the equipment, if found unsatisfactory as to workmanship or material, the same is liable to rejection. Bidder shall grant free access to the places of manufacture to TPCL's representatives at all times when the work is in progress. Inspection by the TPCL or its authorized representatives shall not relieve the bidder of his obligation of furnishing equipment in accordance with the specifications. Material shall be dispatched after specific MDCC (Material Dispatch Clearance Certificate) is issued by TPCL.

Following documents shall be sent along with material:

- a) Test reports
- b) PO copy
- c) MDCC issued by TPCL
- d) Invoice in duplicate
- e) Packing list
- f) Inspection report
- g) Drawings (if applicable) & catalogue
- h) Guarantee / Warrantee card
- i) Delivery Challan
- j) Other Documents (as applicable).

### 10.0 INSPECTION AFTER RECEIPT AT STORES

The material received at TPCL, Bhubaneswar, Odisha store will be inspected for acceptance and shall be liable for rejection, if found different from the reports of the pre-dispatch inspection and one copy of the report shall be sent to Engineering and Contracts department.

### 11.0 GUARANTEE

Bidder shall stand guarantee towards design, materials, workmanship & quality of process/manufacturing of items under this contract for due and intended performance of the same, as an integrated product delivered under this contract. In the event any defect is found by the Purchaser up to a period of at least 12 months from the date of commissioning or 24 months from the date of last supplies made under the contract whichever is later, (the time scale of 12/24 months could be enhanced subject to mutual agreements). Bidder shall be liable to undertake to replace/rectify such defects at its own costs, within mutually agreed time frame, and to the entire satisfaction of the Purchaser, failing which the Purchaser will be at liberty to get it replaced/rectified at Bidder's risks and costs and recover all such expenses plus the Purchaser's own charges (@ 20% of expenses incurred), from the Bidder or from the "Security cum Performance Deposit" as the case may be. Bidder shall further be responsible for 'free replacement' for another period of THREE years from the end of the guarantee period for any 'Latent Defects' if noticed and reported by TPCL.

### 12.0 PACKING

Each coil of wire shall be suitably bound and fastened compactly. Each coil shall be packed by suitable wrapping. The bidder shall ensure that all the Stay Wire shall be adequately protected and specification shall be prepared for rail/road transport in a manner so as to protect the equipment from damage in transit.

### 13.0 TENDER SAMPLE

Bidder shall submit the sample of material with the offer.

Rev No.	Description	Prepared By & Date	Checked By & Date	Approved for Issue By & Date
R0	Specifications for SWG STAY WIRE 7/8 SWG	Sayantani Das	Niranjan Khuntia	Pourush Garg
		05/08/2020	05/08/2020	05/08/2020

<b>TP Central Odisha Distribution Limited</b>	 <b>TPCODL</b> <small>TP CENTRAL ODISHA DISTRIBUTION LIMITED</small>	<b>Specification for Stay Wire 7/8 SWG</b>
<b>NEG-SPEC-01</b>		<b>Date of Issue: 05/08/2020</b>

#### 14.0 QUALITY CONTROL

The bidder shall submit with the offer Quality assurance plan indicating the various stages of inspection, the tests and checks which will be carried out on the material of construction, components during manufacture and bought out items and fully assembled component and equipment after finishing. As part of the plan, a schedule for stage and final inspection within the parameters of the delivery schedule shall be furnished. The Purchaser's engineer or its nominated representative shall have free access to the manufacturer's/sub-supplier's works to carry out inspections. The bidder shall ensure that the material supplied is as per the Guaranteed Technical Particulars as specified in the specifications.

#### 15.0 MINIMUM TESTING FACILITIES

Bidder shall have adequate in house testing facilities for carrying out all routine tests & acceptance tests as per relevant Indian standards. In case of supply by the channel partner, the manufacturer shall have the in house testing facilities to carry out the routine and acceptance tests.

#### 16.0 MANUFACTURING ACTIVITIES

The successful bidder will have to submit the bar chart for various manufacturing activities clearly elaborating each stage, with quantity. This bar chart should be in line with the Quality assurance plan submitted with the offer. This bar chart will have to be submitted within 15 days from the release of the order.

#### 17.0 SPARES, ACCESSORIES AND TOOLS

Not applicable

#### 18.0 DRAWINGS AND DOCUMENTS

Following documents shall be prepared based on TPCL specifications and statutory requirements with complete BOM and shall be submitted with the bid:

- Completely filled in Technical Particulars.
- General description of the equipment and all components including brochures.
- Type test Certificates
- Experience List.

After the after of the contract, four (4) copies of the drawings, drawn to scale, describing the equipment in detail shall be forwarded for approval and shall subsequently provide four (4) complete sets of final drawings, one of which shall be auto positive suitable for reproduction, before the dispatch of the equipment. Soft copy (Compact Disk CD) of all the drawing, GTP, test certificates shall be submitted after the final approval of the same to TPCL.

Following Drawings/Documents shall be submitted after the award of the contract

S.No	Description	For Approval	For Review Information	Final Submission
1	Technical Parameters	√		√
2	Manual/Catalogues/drawings for all components.		√	
3	Technical details of Stay Wire		√	√

Rev No.	Description	Prepared By & Date	Checked By & Date	Approved for Issue By & Date
R0	Specifications for SWG STAY WIRE 7/8 SWG	Sayantani Das	Niranjan Khuntia	Pourush Garg
		05/08/2020	05/08/2020	05/08/2020

<b>TP Central Odisha Distribution Limited</b>	 TP CENTRAL ODISHA DISTRIBUTION LIMITED	<b>Specification for Stay Wire 7/8 SWG</b>
<b>NEG-SPEC-01</b>		<b>Date of Issue: 05/08/2020</b>

4	Installation Instructions		√	√
5	Instructions for use		√	√
6	Transport/shipping dimensions		√	√
7	QA & QC Plan	√	√	√
8	Routine, Acceptance and Type test Certificates	√	√	√

All the Documents and Drawings shall be in English Language.

**Instruction Manuals:** Bidder shall furnish two (2) soft copies (CD) and four (4) hard copies of nicely bound manual (in English Language) covering erection and maintenance instructions and all relevant information pertaining to the main equipment as well as auxiliary devices

#### 19.0 GUARANTEED TECHNICAL PARTICULARS

Sl. No.	Technical Parameter	Unit	Requirement
	Size of Wire mm		To be submitted by bidder
	Standard	mm	
	<b>Min</b>	mm	
	<b>Max</b>	mm	
<b>2</b>	Diameter of Strand	mm	
<b>3</b>	Min breaking force of strand	kN	
<b>4</b>	Min Tensile strength of single wire before stranding	kN	
<b>5</b>	Lay ratio		
<b>6</b>	Weight of Zn coating after strand		
<b>7</b>	No of dips (Uniformity of Zn coating) before Strand		
	After strand		
<b>8</b>	Adhesion of Zn coating		
<b>9</b>	Min Elongation %	%	

Rev No.	Description	Prepared By & Date	Checked By & Date	Approved for Issue By & Date
R0	Specifications for SWG STAY WIRE 7/8 SWG	Sayantani Das	Niranjan Khuntia	Pourush Garg
		05/08/2020	05/08/2020	05/08/2020

<b>TP Central Odisha Distribution Limited</b>	<b>TPCODL</b>  TP CENTRAL ODISHA DISTRIBUTION LIMITED	<b>Specification for Stay Wire 7/8 SWG</b>
<b>NEG-SPEC-01</b>		<b>Date of Issue: 05/08/2020</b>

20.0

**SCHEDULE OF DEVIATIONS**

**(TO BE ENCLOSED WITH TECHNICAL BID)**

All deviations from this specification shall be set out by the Bidders, clause by Clause in this schedule. Unless specifically mentioned in this Schedule, the tender shall be deemed to confirm the purchaser's specifications:

Sl. No	Clause No.	Details of deviation with justifications

We confirm that there are no deviations apart from those detailed above.

Seal of the Company:

Signature

Designation

Rev No.	Description	Prepared By & Date	Checked By & Date	Approved for Issue By & Date
R0	Specifications for SWG STAY WIRE 7/8 SWG	Sayantani Das	Niranjan Khuntia	Pourush Garg
		05/08/2020	05/08/2020	05/08/2020



**Technical Specification  
For  
TOP BRACKET (HMAPER CLAMP)**

**TP Central Odisha Distribution Limited.  
Network Engineering Group  
2<sup>nd</sup> Floor, IDCO Tower  
Janpath, Bhubaneswar- 751022**

Rev No.	Description	Prepared By & Date	Checked By & Date	Approved for Issue By & Date
R0	Specifications for TOP BRACKET (HMAPER CLAMP)	Sayantani Das	Niranjan Khuntia	Pourush Garg
		05/08/2020	05/08/2020	05/08/2020



<b>TP Central Odisha Distribution Limited</b>	 TP CENTRAL ODISHA DISTRIBUTION LIMITED	<b>SPECIFICATION FOR TOP BRACKET</b>
<b>NEG-SPEC-04</b>		<b>Date of Issue: 05/08/2020</b>

## 11KV TOP BRACKET

### CONTENTS

1. SCOPE
2. APPLICABLE STANDARDS
3. CLIMATIC CONDITIONS OF THE INSTALLATION
4. GENERAL CONSTRUCTIONS
5. GENERAL TECHNICAL REQUIREMENTS
6. MARKING
7. TESTS
8. TYPE TEST CERTIFICATES
9. PRE-DESPATCH INSPECTION
10. INSPECTION AFTER RECEIPT AT STORES
11. GUARANTEE
12. PACKING
13. TENDER SAMPLE
14. QUALITY CONTROL
15. MINIMUM TESTING FACILITIES
16. MANUFACTURING ACTIVITIES
17. SPARES, ACCESSORIES AND TOOLS
18. DRAWINGS
19. SCHEDULE OF DEVIATIONS

Rev No.	Description	Prepared By & Date	Checked By & Date	Approved for Issue By & Date
R0	Specifications for TOP BRACKET (HMAPER CLAMP)	Sayantani Das	Niranjan Khuntia	Pourush Garg
		05/08/2020	05/08/2020	05/08/2020

<b>TP Central Odisha Distribution Limited</b>	 TP CENTRAL ODISHA DISTRIBUTION LIMITED	<b>SPECIFICATION FOR TOP BRACKET</b>
<b>NEG-SPEC-04</b>		<b>Date of Issue: 05/08/2020</b>

## 1.0 SCOPE

The scope of this document is to give design & constructional features, inspection, supply and transportation of top hamper clamp for trouble free operation at TPCL.

## 2.0 APPLICABLE STANDARDS

The equipment covered by this specification shall unless otherwise stated, be designed, manufactured and tested in accordance with latest editions of the following standards/IEC and shall conform to the regulations of local statutory authorities.

- a) IS 4759-1996 - For Hot dip zinc coatings on structural steel and other allied products-specification
- b) IS 2062: 2006 - Hot Rolled Low, Medium and High Tensile Structural Steel.
- c) IS 2633 - Methods for testing uniformity of coating on zinc coated articles.

## 3.0 CLIMATIC CONDITIONS OF THE INSTALLATION:

The service conditions shall be as follows:

1. Maximum altitude above sea level 1,000m
2. Maximum ambient air temperature 50°C
3. Maximum daily average ambient air temperature 35°C
4. Minimum ambient air temperature 0°C
5. Maximum relative humidity 95%
6. Average number of thunderstorm days per annum (isokeraunic level) 70
7. Average number of rainy days per annum 120
8. Average annual rainfall 150cm
9. Earthquakes of an intensity in horizontal direction - equivalent to seismic acceleration of 0.3g
10. Earthquakes of an intensity in vertical direction - equivalent to seismic acceleration of 0.15g (g being acceleration due to gravity)
11. Wind velocity: 300 km/hr, 200 km/hr and 160 km/hr.

Environmentally, some of the regions, where the work will take place includes coastal areas, subject to high relative humidity, which can give rise to condensation. Onshore winds will frequently be salt laden. On occasions, the combination of salt and condensation may create pollution conditions for outdoor insulators. Some places are in heavily industrial polluted areas.

Therefore, Outdoor material and equipment shall be designed and protected for use in exposed, heavily polluted, salty, corrosive and humid coastal atmosphere

The design of equipment and accessories shall be suitable to withstand seismic forces corresponding to an acceleration of 0.1 g.

Rev No.	Description	Prepared By & Date	Checked By & Date	Approved for Issue By & Date
R0	Specifications for TOP BRACKET (HMAPER CLAMP)	Sayantani Das	Niranjan Khuntia	Pourush Garg
		05/08/2020	05/08/2020	05/08/2020

<b>TP Central Odisha Distribution Limited</b>	 TP CENTRAL ODISHA DISTRIBUTION LIMITED	<b>SPECIFICATION FOR TOP BRACKET</b>
<b>NEG-SPEC-04</b>		<b>Date of Issue: 05/08/2020</b>

#### 4.0 GENERAL CONSTRUCTION:

##### The material shall be-

- a) All parts shall be of MS Grade E 250 as per IS 2062 and hot dip galvanizing shall be done as per IS 4759:1996
- b) The design shall be suitable for the climatic condition stated above.
- c) The product shall be supplied strictly in line with the attached drawing no: TPD-S-116-S-025
- d) Dimensional tolerance shall be as per IS 1852.
- e) Zinc electroplated/painted material will not be accepted.
- f) Fabrication tolerances should be  $\pm 2\%$  until and unless otherwise specified.
- g) All fabrication works including welding should be done before galvanization only.
- h) 33 KV line pole top bracket made out of 65 mm long 100x50x6 mm M.S channel welded with 65x65x6 mm M.S Angle & hot dip galvanize as per IS-2633/1972.(Latest Amendment) , confirming to REC Construction Standard.M-4 & drawing .
- i) GI nut, bolt and washer of 16 mm dia. and 300mm long-hot dip galvanized as per IS 4759:1996.
- j) The thread on the bolt should be enough for proper tightening of nut and washer.
- k) The design shall be suitable to hold the 11Kv pin insulator on 11 meter HT pole.
- l) Ferrous parts shall be hot dip galvanized as per IS: 2633.

#### 5.0 GENERAL TECHNICAL REQUIREMENTS:

##### 5.1 FOR 11KV TOP BRACKET:

Sl.No.	Constructional Features	Specified
1.	Material used	65x65x6 mm MS Angle & 100x50x6 mm MS Channel
2.	Overall height	380 mm
3.	Flange Width (one welded &	65 mm
4.	Spacing between two flanges	100mm
5.	Spacing of 2 nos of 18 mm holes for fixing on pole top	100mm
6.	C/L Distance of 2nos of 25mm holes on top flanges of the bracket	40mm from edge of the flange
7.	Galvanization	Hot dip
8.	ISS	2062 ,2633
9.	Drawing	enclosed

Rev No.	Description	Prepared By & Date	Checked By & Date	Approved for Issue By & Date
R0	Specifications for TOP BRACKET (HMAPER CLAMP)	Sayantani Das	Niranjan Khuntia	Pourush Garg
		05/08/2020	05/08/2020	05/08/2020

<b>TP Central Odisha Distribution Limited</b>	 TP CENTRAL ODISHA DISTRIBUTION LIMITED	<b>SPECIFICATION FOR TOP BRACKET</b>
<b>NEG-SPEC-04</b>		<b>Date of Issue: 05/08/2020</b>

#### 6.0 MARKING:

The unit shall be appropriately marked as "**PROPERTY OF TPCODL, BHUBANESWAR**" and with the name of the vendor and year of manufacturing at suitable location.

#### 7.0 TESTS

All routine, acceptance & type tests shall be carried out in accordance with the relevant IS/IEC.

All routine/acceptance tests shall be witnessed by the purchaser/his authorized representative. All components shall also be type tested as per the relevant standards.

Tests	IS to be referred
Visual test	As a routine test
Dimensional tests	As per the drawing
Hot dip galvanizing	IS 4759
Determination of mass of zinc coating on zinc coated iron and steel	IS 4759
Tensile test	IS 2062
Bend test	IS 2062
Impact test	IS 2062

#### 8.0 TEST CERTIFICATES

The bidder shall furnish the test certificates for the tests as mentioned above as per the corresponding standards. All the tests shall be conducted at NABL accredited as per the relevant standards. Type test should have been conducted during the period not exceeding 5 years from the date of opening the bid. In the event of any discrepancy in the test reports i.e. any test report not acceptable or any/all type tests (including additional type tests, if any) not carried out, same shall be carried out without any cost implication to TPCL.

#### 9.0 PRE DISPATCH INSPECTION

Equipment shall be subjected to inspection by a duly authorized representative of TPCL. Inspection may be made at any stage of manufacture at the discretion of the purchaser and the equipment, if found unsatisfactory as to workmanship or material, the same is liable to rejection. Bidder shall grant free access to the places of manufacture to TPCL's representatives at all times when the work is in progress. Inspection by TPCL or its authorized representatives shall not relieve the bidder of his obligation of furnishing equipment in accordance with the specifications. Material shall be dispatched after specific MDCC (Material Dispatch Clearance Certificate) is issued by TPCL.

Following documents shall be sent along with material.

- a) Test reports
- b) MDCC issued by TPCL
- c) Invoice in duplicate
- d) Packing list
- e) Drawings & catalogue
- f) Guarantee / Warrantee card
- g) Delivery Challan
- h) Other Documents (as applicable)

Rev No.	Description	Prepared By & Date	Checked By & Date	Approved for Issue By & Date
R0	Specifications for TOP BRACKET (HMAPER CLAMP)	Sayantani Das	Niranjan Khuntia	Pourush Garg
		05/08/2020	05/08/2020	05/08/2020

<b>TP Central Odisha Distribution Limited</b>	 TP CENTRAL ODISHA DISTRIBUTION LIMITED	<b>SPECIFICATION FOR TOP BRACKET</b>
<b>NEG-SPEC-04</b>		<b>Date of Issue: 05/08/2020</b>

#### 10.0 INSPECTION AFTER RECEIPT AT STORES

The material received at TPCL, Bhubaneswar, Odisha store will be inspected for acceptance and shall be liable for rejection, if found different from the reports of the pre-dispatch inspection and one copy of the report shall be sent to Engineering / contracts department.

#### 11.0 GUARANTEE

Bidder shall stand guarantee towards design, materials, workmanship & quality of process / manufacturing of items under this contract for due and intended performance of the same, as an integrated product delivered under this contract. In the event any defect is found by the Company up to a period of at least 12 months from the date of commissioning or 24 months from the date of last supplies made under the contract whichever is later. In the event any defect is found by the Company up to a period of 12 months from the date of commissioning or 24 months from the date of last supplies made under the contract, whichever is earlier, supplier shall be liable to undertake to replace/rectify such defects at his own costs.

#### 12.0 PACKING

Bidder shall ensure that all the equipment covered under this specification shall be prepared for rail/road transport in a manner so as to protect the equipment from damage in transit.

#### 13.0 TENDER SAMPLE

To be provided.

#### 14.0 QUALITY CONTROL

The bidder shall submit with the offer Quality assurance plan indicating the various stages of inspection, the tests and checks which will be carried out on the material of construction, components during manufacture and bought out items and fully assembled component and equipment after finishing. As part of the plan, a schedule for stage and final inspection within the parameters of the delivery schedule shall be furnished. TPCL's engineer or its nominated representative shall have free access to the manufacturer's/sub-supplier's works to carry out inspections.

#### 15.0 MINIMUM TESTING FACILITIES

Bidder shall have adequate in house testing facilities for carrying out all routine tests & acceptance tests as per relevant International / Indian standards

#### 16.0 MANUFACTURING ACTIVITIES

The successful bidder will have to submit the bar chart for various manufacturing activities clearly elaborating each stage, with quantity. This bar chart should be in line with the Quality assurance plan submitted with the offer. This bar chart will have to be submitted within 15 days from the release of the order.

#### 17.0 SPARES, ACCESSORIES AND TOOLS

NA

#### 18.0 DRAWINGS

Following drawings & documents shall be prepared based on Purchaser's specifications and statutory requirements with complete BOM and shall be submitted with the bid:

- a) Completely filled-in Technical Parameters (refer Cl. 5)

Rev No.	Description	Prepared By & Date	Checked By & Date	Approved for Issue By & Date
R0	Specifications for TOP BRACKET (HMAPER CLAMP)	Sayantani Das	Niranjan Khuntia	Pourush Garg
		05/08/2020	05/08/2020	05/08/2020

<b>TP Central Odisha Distribution Limited</b>	 TP CENTRAL ODISHA DISTRIBUTION LIMITED	<b>SPECIFICATION FOR TOP BRACKET</b>
<b>NEG-SPEC-04</b>		<b>Date of Issue: 05/08/2020</b>

- b) General description of the equipment and all components including brochures
- c) General arrangement drawings
- d) Bill of material
- e) Type Test Certificates.
- f) Experience List
- g) Manufacturing schedule and test schedule.

After the contract, four (4) copies of the drawings, drawn to scale, describing the equipment in detail shall be forwarded for approval and shall subsequently provide four (4) complete sets of final drawings, one of which shall be auto positive suitable for reproduction, before the dispatch of the equipment. Soft copy (Compact Disk CD) of all the drawing, GTP, test certificates shall be submitted after the final approval of the same to the purchaser.

Following Drawings/Documents shall be submitted after the award of the contract:

Drawings/documents to be submitted after the award of the contract:

S.No	Description	For Approval	For Review Information	Final Submission
1	Technical Parameters	√		√
2	General Arrangement drawings	√		√
3	Instruction for Use		√	√
4	QA & QC Plan	√	√	√
5	Routine, Acceptance & Type Test Certificates	√	√	√

All the documents & drawings shall be in English language.

Rev No.	Description	Prepared By & Date	Checked By & Date	Approved for Issue By & Date
R0	Specifications for TOP BRACKET (HMAPER CLAMP)	Sayantani Das	Niranjan Khuntia	Pourush Garg
		05/08/2020	05/08/2020	05/08/2020

<b>TP Central Odisha Distribution Limited</b>	 TP CENTRAL ODISHA DISTRIBUTION LIMITED	<b>SPECIFICATION FOR TOP BRACKET</b>
<b>NEG-SPEC-04</b>		<b>Date of Issue: 05/08/2020</b>

**19.0 SCHEDULE OF DEVIATIONS**

**SCHEDULE OF DEVIATIONS**

**(TO BE ENCLOSED WITH TECHNICAL BID)**

All deviations from this specification shall be set out by the Bidders, clause by Clause in this schedule. Unless specifically mentioned in this Schedule, the tender shall be deemed to confirm the purchaser's specifications:

S.No	Clause No.	Details of deviation with justifications

We confirm that there are no deviations apart from those detailed above.

Seal of the Company:

Signature

Designation

Rev No.	Description	Prepared By & Date	Checked By & Date	Approved for Issue By & Date
R0	Specifications for TOP BRACKET (HMAPER CLAMP)	Sayantani Das	Niranjan Khuntia	Pourush Garg
		05/08/2020	05/08/2020	05/08/2020



<b>TP Central Odisha Distribution Limited</b>	<b>TPCODL</b> <small>TP CENTRAL ODISHA DISTRIBUTION LIMITED</small>	<b>SPECIFICATION FOR LT ABC Conductor</b>
<b>NEG-SPEC-13</b>		<b>Date of Issue: 05/08/2020</b>

**Technical Specification  
For  
LT ABC Conductor**

**TP Central Odisha Distribution Limited.  
Network Engineering Group  
2<sup>nd</sup> Floor, IDCO Tower  
Janpath, Bhubaneswar- 751022**

Rev No.	Description	Prepared By & Date	Checked By & Date	Approved for Issue By & Date
RO	Specifications for LT ABC Conductor	Anil Sah	Niranjan Khuntia	Pourush Garg
		05/08/2020	05/08/2020	05/08/2020



TP Central Odisha Distribution Limited	 TP CENTRAL ODISHA DISTRIBUTION LIMITED	SPECIFICATION FOR LT ABC Conductor
NEG-SPEC-13		Date of Issue: 05/08/2020

## CONTENTS

1. SCOPE
2. APPLICABLE STANDARDS
3. CLIMATIC CONDITIONS OF THE INSTALLATION
- 4 GENERAL TECHNICAL REQUIREMENTS
- 5 GENERAL CONSTRUCTIONS
6. MARKING
7. TESTS
- 8 TYPE TEST CERTIFICATES
- 9 PRE-DISPATCH INSPECTION
- 10 INSPECTION AFTER RECEIPT AT STORES
- 11 GUARANTEE
- 12 PACKING
- 13 TENDER SAMPLE
- 14 QUALITY CONTROL
- 15 MINIMUM TESTING FACILITIES
- 16 MANUFACTURING ACTIVITIES
- 17 SPARES, ACCESSORIES AND TOOLS
- 18 DRAWINGS AND DOCUMENTS
- 19 GUARANTEED TECHNICAL PARTICULARS
- 20 SCHEDULE OF DEVIATIONS

Rev No.	Description	Prepared By & Date	Checked By & Date	Approved for Issue By & Date
R0	Specifications for LT ABC Conductor	Anil Sah	Niranjan Khuntia	Pourush Garg
		05/08/2020	05/08/2020	05/08/2020

<b>TP Central Odisha Distribution Limited</b>	 <small>TP CENTRAL ODISHA DISTRIBUTION LIMITED</small>	<b>SPECIFICATION FOR LT ABC Conductor</b>
<b>NEG-SPEC-13</b>		<b>Date of Issue: 05/08/2020</b>

## 1. SCOPE

This specification covers the technical requirements of design, manufacture, test at manufacturer's works, packing & forwarding, supply and unloading at stores/ site and performance of LT ABC cable for trouble free and efficient operation. The specific requirements are covered in the enclosed technical data sheet.

## 2. APPLICABLE STANDARDS

The equipment covered by this specification shall unless otherwise stated, be designed, manufactured and tested in accordance with the latest editions of the following Indian, International Standards and shall conform to the regulations of the local authorities:

Rev No.	Description	Prepared By & Date	Checked By & Date	Approved for Issue By & Date
RO	Specifications for LT ABC Conductor	Anil Sah	Niranjan Khuntia	Pourush Garg
		05/08/2020	05/08/2020	05/08/2020

TP Central Odisha Distribution Limited	<b>TPCODL</b> <small>TP CENTRAL ODISHA DISTRIBUTION LIMITED</small>	SPECIFICATION FOR LT ABC Conductor
NEG-SPEC-13		Date of Issue: 05/08/2020

IS-398 (Part IV): 1994	Aluminum conductor for overhead transmission purposes- Part IV Aluminum alloy stranded conductor
IS-5216	Guide for safety procedures and practices in electric works
IS-5831:1984	Specification for PVC insulation and sheath of electric cables.
IS-7098 (Part I): 1988	Specification for Cross-linked polyethylene insulated PVC sheathed cables-Part I for working voltages up to and including 1100 volts.
IS-8130:1984	Specification for Conductor for insulated electric cables & flexible cords.
IS-10418:1982	Specification for drums for electric cables
BS-5468	Cross-linked polyethylene insulation of electric cables
IEC-540	Test methods for insulations and sheaths of electric cables and cords
IEC-60228/3-2004	Conductor for insulated cables
IEC-60502-1/2004	Power cables with extruded insulation and their accessories for rated voltages from 1 kV (Um=1.2kV), up to 30kV (Um=36kV)-Part 1 :Cables for rated voltages of 1 kV /Um=1,2kV) and 3kV/Um=3.6kV)
ASTM G-53/DIN 56687	UV testing of XLPE insulation
SANS 1713:2004	South African Standard for Aerial Bunched conductor
IS14255:1995	Aerial Bunched conductors for working voltages up to and including 1100 volts

### 3. CLIMATIC CONDITIONS OF THE INSTALLATION:

- a) Max. Ambient Temperature : 50degC
- b) Max. Daily average ambient temp :40 degC
- c) Max. Soil temp at cable length: 35 degC
- d) Maximum Humidity :100%
- e) Minimum Humidity :10%
- f) Average No. of thunderstorm per annum : 50
- g) Average Annual Rainfall : 750
- h) Average No. of rainy days per annum :60
- i) Rainy months : June to Oct

Rev No.	Description	Prepared By & Date	Checked By & Date	Approved for Issue By & Date
RO	Specifications for LT ABC Conductor	Anil Sah	Niranjan Khuntia	Pourush Garg
		05/08/2020	05/08/2020	05/08/2020

TP Central Odisha Distribution Limited	 TP CENTRAL ODISHA DISTRIBUTION LIMITED	SPECIFICATION FOR LT ABC Conductor
NEG-SPEC-13		Date of Issue: 05/08/2020

- j) Altitude above MSL not exceeding : 300 meters  
k) Wind Pressure : 126 kg/sq tn up an elevation of 10m

Atmosphere is generally laden with mild acid and dust suspended during dry months and subjected to fog in cold months. The design of the equipment and accessories shall be suitable to withstand seismic forces corresponding to an acceleration of 0.1 g .

#### 4. GENERAL TECHNICAL REQUIREMENTS

##### A) 4X150+1X150+1X16 SQMM

SI no	Description	Units	Requirement
1	Type of cable		LT ABC cable with cross linked polyethylene insulated Phase neutral and street lighting core twisted around the bare earth cum messenger wire.
2	Size of Aerial Bunched cable		4Cx150 mm <sup>2</sup> +1Cx150 mm <sup>2</sup> +1CX16 mm
3	Rated Voltage	KV	1.1
4	System Voltage	KV	0.415
5	Nominal Area of Phase Conductor	mm <sup>2</sup>	150
6	Nominal Area of Messenger	Mm <sup>2</sup>	150
7	Phase Core & Neutral core		Stranded compacted circular Aluminum Conductor, Extruded XLPE Insulated cable
8	Messenger Wire		Circular/Compacted circular Aluminum, AlloyWire.
9	Standard length of the cable with tolerance	m	500+/-5%
10	Maximum conductor temperature durinQ continuous operation	deg C	90
11	Maximum conductor temperature durina short circuit	deg C	250
12	Phase Core RYBN		

Rev No.	Description	Prepared By & Date	Checked By & Date	Approved for Issue By & Date
RO	Specifications for LT ABC Conductor	Anil Sah	Niranjan Khuntia	Pourush Garg
		05/08/2020	05/08/2020	05/08/2020

TP Central Odisha Distribution Limited	 TP CENTRAL ODISHA DISTRIBUTION LIMITED	SPECIFICATION FOR LT ABC Conductor
NEG-SPEC-13		Date of Issue: 05/08/2020

	<b>insulated</b>		
<b>a)</b>	<b>Conductor</b>		
	(i) <b>Material</b>		<b>EC Grade Aluminum of H2/H4 Grade to IS:8130:1984</b>
	(ii) <b>No. of Cores &amp; Nominal Size</b>	<b>Mm2</b>	<b>4C*150</b>
	(iii) <b>Minimum number of wires/Diameter</b>		<b>19/3.15</b>
	<b>Max. DC Resistance at 20 deg. C</b>	<b>Ohm/KM</b>	<b>0.206</b>
	<b>Shape of Conductor</b>		<b>Stranded Compacted Circular</b>
	<b>Short Circuit current rating of conductor for 1 sec</b>	<b>KA</b>	<b>14.17</b>
	<b>Continuous current rating in air at 40 DeQ.C</b>	<b>A</b>	<b>300</b>
<b>b)</b>	<b>INSULATION</b>		
	i) <b>Material</b>		<b>XLPE Insulation as per IS 7098 Part-1 clause No. 4.1</b>
	ii) <b>Nominal Thickness</b>	<b>Mm</b>	<b>1.7</b>
	<b>Tolerance in Insulation Thickness</b>	<b>Mm</b>	<b>As per clause No. 9.3 of IS 7098 Part-1</b>
<b>13</b>	<b>Street light core</b>		
<b>a</b>	<b>Conductor</b>		
	i) <b>Material</b>		<b>EC grade aluminum of H2/H4 grade to IS:8130: 1984</b>
	ii) <b>Nominal size</b>	<b>Mm2</b>	<b>16</b>
	<b>Nominal no. of wire</b>		<b>As per Bidder</b>
	<b>Max DC resistance at 20 deg. C</b>	<b>Ohm/KM</b>	<b>1.91(As per IS 8130:1984)</b>
	<b>Shape of conductor</b>		<b>Stranded compacted circular</b>
<b>b</b>	<b>Insulation</b>		
	<b>Material</b>		<b>As per IS:14255:1995</b>
	<b>Nominal thickness</b>		<b>1.2</b>
	<b>Tolerance in Insulation Thickness</b>		<b>As per clause No. 9.3 of IS 7098 Part-1</b>
<b>13</b>	<b>Earth Cum Messenger Wire</b>		
<b>a</b>	<b>Messenger wire</b>		
	<b>Material</b>		<b>Aluminum Alloy Wire</b>
	<b>Nominal size</b>	<b>Mm2</b>	<b>150</b>
	<b>No. and Nominal Dia. of</b>	<b>No./mm</b>	<b>19/3.15</b>

Rev No.	Description	Prepared By & Date	Checked By & Date	Approved for Issue By & Date
RO	Specifications for LT ABC Conductor	Anil Sah	Niranjan Khuntia	Pourush Garg
		05/08/2020	05/08/2020	05/08/2020

TP Central Odisha Distribution Limited	 TP CENTRAL ODISHA DISTRIBUTION LIMITED	SPECIFICATION FOR LT ABC Conductor
NEG-SPEC-13		Date of Issue: 05/08/2020

	each strand		
	App. Calculated Breaking Load	KN	43.5kn (MIN)
	Calculated Maximum resistance at 20 deqC	ohm/km	0.229
	Shape of conductor		Stranded circular-compacted
	Short circuit rating for 1 sec	kA	14.1
14	Core Identification		RIDGES REQUIRE:D for Phase identification: 1 ridge for R phase 2 ridges for Y phase 3 ridges for B phase For neutral core identification non contact type laser printing or ink jet printing to be provided with 'N' printed on it at every span of 1 ft.
15	Formation of cable		Four (RYBN) insulated phase and street light core shall be twisted around the bare EARTH cum messenger wire to form the circular assembly
16	Approx. weight of the messenger	Kg/Km	To be provided by the bidder
17	Continuous current rating in air at 40DeQC (RYBN/MessenQer)	A	300
18	Maximum conductor temperature during continuous operation (RYBN)	Deg C	90
19	Maximum conductor temperature durina Short circuit (RYBN)	Deg C	250
20	Short circuit rating for 1 sec	kA	14.1
21	Standard Drum Length	Mtr	500
22	Tolerance in Drum length	%	+/- 5%

Rev No.	Description	Prepared By & Date	Checked By & Date	Approved for Issue By & Date
RO	Specifications for LT ABC Conductor	Anil Sah	Niranjan Khuntia	Pourush Garg
		05/08/2020	05/08/2020	05/08/2020

TP Central Odisha Distribution Limited	 TP CENTRAL ODISHA DISTRIBUTION LIMITED	SPECIFICATION FOR LT ABC Conductor
NEG-SPEC-13		Date of Issue: 05/08/2020

**B) 4X70+1X70+1X16 SQMM**

Sl no	Description	Units	Requirement
1	Type of cable		LT ABC cable with cross linked polyethylene insulated Phase neutral and street lighting core twisted around the bare earth cum messenger wire.
2	Size of Aerial Bunched cable		4Cx70 mm <sup>2</sup> (P)+1Cx70 mm <sup>2</sup> (M)+1CX16 mm <sup>2</sup> Street Liahtl
3	Rated Voltage	KV	1.1
4	System Voltage	KV	0.415
5	Nominal Area of Phase Conductor	mm <sup>2</sup>	70
6	Nominal Area of Messenger	Mm <sup>2</sup>	70
7	Phase Core & Neutral core		Stranded aluminum conductor, XLPE insulated
8	Messenger Wire		Circular/Compacted circular Aluminum, AlloyWire.
9	Standard length of the cable with tolerance	m	500+/-5%
10	Maximum conductor temperature durinQ continuous operation	deg C	90
11	Maximum conductor temperature durina short circuit	deg C	250
12	Phase Core RYBN insulated		
a)	Conductor		
	(i) Material		EC Grade Aluminum of H2/H4 Grade to IS:8130:1984
	(ii) No. of Cores & Nominal Size	Mm <sup>2</sup>	4C*70
	(iii) Minimum number of wires/Diameter		18/2.23
	Max. DC Resistance at 20 deg. C	Ohm/KM	0.443
	Shape of Conductor		Stranded Compacted Circular
	Short Circuit current	KA	6.58

Rev No.	Description	Prepared By & Date	Checked By & Date	Approved for Issue By & Date
RO	Specifications for LT ABC Conductor	Anil Sah 05/08/2020	Niranjan Khuntia 05/08/2020	Pourush Garg 05/08/2020



TP Central Odisha Distribution Limited	 TP CENTRAL ODISHA DISTRIBUTION LIMITED	SPECIFICATION FOR LT ABC Conductor
NEG-SPEC-13		Date of Issue: 05/08/2020

	rating of conductor for 1 sec		
	Continuous current rating in air at 40 DeQ.C	A	200
b)	INSULATION		
	i) Material		XLPE Insulation as per IS 7098 Part-1 clause No. 4.1
	ii) Nominal Thickness	Mm	1.4
	Tolerance in Insulation Thickness	Mm	As per clause No. 9.3 of IS 7098 Part-1
13	Street light core		
a	Conductor		
	ii) Material		C grade aluminum of H2/H4 grade to IS:8130: 1984
	ii) Nominal size	Mm <sup>2</sup>	16
	Nominal no. of wire		As per Bidder
	Max DC resistance at 20 deg. C	Ohm/KM	1.91(As per IS 8130:1984)
	Shape of conductor		Stranded compacted circular
b	Insulation		
	Material		As per IS:14255:1995
	Nominal thickness		1.2
	Tolerance in Insulation Thickness		As per clause No. 9.3 of IS 7098 Part-1
13	Earth Cum Messenger Wire		
a	Messenger wire		
	Material		Aluminum Alloy Wire
	Nominal size	Mm <sup>2</sup>	70
	No. and Nominal Dia. of each strand	No./mm	7/3.57
	App. Calculated Breaking Load	KN	19.7
	Calculated Maximum resistance at 20 degC	ohm/km	0.492
	Shape of conductor		Stranded circular-compact
	Short circuit rating for 1 sec	kA	6.58
14	Core Identification		RIDGES REQUIRE:D for Phase identification: 1 ridge for R phase 2 ridges for Y phase

Rev No.	Description	Prepared By & Date	Checked By & Date	Approved for Issue By & Date
R0	Specifications for LT ABC Conductor	Anil Sah	Niranjan Khuntia	Pourush Garg
		05/08/2020	05/08/2020	05/08/2020



TP Central Odisha Distribution Limited	 TP CENTRAL ODISHA DISTRIBUTION LIMITED	SPECIFICATION FOR LT ABC Conductor
NEG-SPEC-13		Date of Issue: 05/08/2020

			3 ridges for B phase For neutral core identification non contact type laser printing or ink jet printing to be provided with 'N' printed on it at every span of 1 ft.
15	Formation of cable		Four cores XLPE; insulated along with street light core shall be twisted around the bare earth cum messenger wire .
16	Approx. weight of the messenger	Kg/Km	To be provided by the bidder
17	Continuous current rating in air at 40DeQC (RYBN/Messenger)	A	200
18	Maximum conductor temperature during continuous operation (RYBN)	Deg C	90
19	Maximum conductor temperature during Short circuit (RYBN)	Deg C	250
20	Short circuit rating for 1 sec	kA	6.58
21	Standard Drum Length	Mtr	500
22	Tolerance in Drum length	%	+/- 5%

## 5. GENERAL CONSTRUCTIONS

### 5.1 CONDUCTORS

5. 1.1 All conductors shall be Class 2, Stranded, compared circular, High electrical conductivity, Aluminum, Grade H2/H4 as per IS 8130:1984.

5. 1.2. Before stranding, the conductor shall be circular in cross section, uniform in quality, solid, smooth and free from scale, sharp edges and other defects.

Rev No.	Description	Prepared By & Date	Checked By & Date	Approved for Issue By & Date
R0	Specifications for LT ABC Conductor	Anil Sah	Niranjana Khuntia	Pourush Garg
		05/08/2020	05/08/2020	05/08/2020

TP Central Odisha Distribution Limited	 TP CENTRAL ODISHA DISTRIBUTION LIMITED	SPECIFICATION FOR LT ABC Conductor
NEG-SPEC-13		Date of Issue: 05/08/2020

5.1.3. Conductor shall conform to the standards for permissible number of joints in any one of the single wires forming every complete length of conductor, for location of joints in same layer of conductors and for method of making such joints. No joint shall be made in any conductor after it is stranded.

5.1.4. All conductors shall be of high electrical conductivity Aluminum as specified, conforming to requirement of relevant standards.

## 5.2 INSULATION

5.2.1. The insulating material shall be Cross Linked Polyethylene (XLPE) applied by extrusion as per IS-7098 (Part I): 1988 and its latest amendments clause no. 4.1.

5.2.2. The insulation shall be both heat and moisture resistant and shall be suitable for continuous operation at conductor temperature of 90 Degree Centigrade, rising momentarily to 250 Degree Centigrade under short circuit conditions.

5.2.3. It shall be free from any foreign material or porosity visible to unaided eye. The insulation shall be so applied that it fits closely to the conductor and it shall be possible to remove insulation without damaging the conductor. The XLPE insulation shall be ultraviolet protected for operation in direct sunlight.

5.2.4. It shall be free from any foreign material or porosity visible to unaided eye. The insulation shall be so applied that it fits closely to the conductor and it shall be possible to remove insulation without damaging the conductor. Average thickness of the insulation shall not be less than nominal value specified in IS- 7098 (Part-I) with latest amendments. The tolerance on the thickness shall be as specified in IS-7098 (Part-I): 1988.

5.2.5. The insulating material shall have excellent electrical properties with regard to resistivity, dielectric constant and loss factor and shall have high tensile strength and resistance to abrasion. This shall not deteriorate at elevated temperatures or when immersed in water. The insulation shall be preferably fire resistant and resistant to chemicals like acids, alkalis, oils and ozone.

## 5.3 MESSENGER WIRE

5.3.1 The bare messenger wire shall be of 150 mm<sup>2</sup> and 70 mm<sup>2</sup> (nominal cross section area) for 4CX150 mm<sup>2</sup> and 4Cx70 mm<sup>2</sup> ABC respectively and shall be made 6f aluminum alloy, generally conforming to IS: 398(Part-IV): 1994. The conductor shall be of heated aluminum-magnesium-silicon alloy wires containing approximate 0.5% magnesium and approximately 0.5% silicon conforming to IS 398(Part 4).

## 5.4 CORE IDENTIFICATION

Rev No.	Description	Prepared By & Date	Checked By & Date	Approved for Issue By & Date
RO	Specifications for LT ABC Conductor	Anil Sah	Niranjan Khuntia	Pourush Garg
		05/08/2020	05/08/2020	05/08/2020

TP Central Odisha Distribution Limited	 TP CENTRAL ODISHA DISTRIBUTION LIMITED	SPECIFICATION FOR LT ABC Conductor
NEG-SPEC-13		Date of Issue: 05/08/2020

The following shall be embossed on the one side of the core:  
**RIDGES REQUIRED for Phase identification:**

- 1 ridge for R phase
- 2 ridges for Y phase
- 3 ridges for B phase

For neutral core identification non-contact type laser printing or ink jet printing to be provided with 'N' printed on it at every span of 1 ft.

#### 5.5 LAYING OF CORES

Cores shall be laid up with a right-hand lay, and shall have a lay length not exceeding  $28(d_1+d_2)$ , where;  $d_1$  is the core diameter, including sheath, in mm.  $d_2$  is the diameter of the messenger, including the outer protective covering where applicable, in mm.

#### 5.6 STRANDING

The wire used in the construction of a stranded conductor shall, before and after stranding, satisfy all the relevant requirements of IS 398(Part-IV): 1994. The lay ratio of the different layers shall be within the limits given in IS 398(Part-IV) : 1994. The successive layers shall have opposite directions of lay, the outermost layer being right - handed. The wires in each layer shall be evenly and closely stranded. The lay ratio of any layer shall not be greater than the lay ratio of layer immediately beneath it.

#### 5.7 CABLE DRUM

Cables shall be furnished in the specified reels or coil lengths of 500 meters. Drums shall be of non-returnable wooden drums as per IS 10418:1982 and the drums should be free from defects such as through cracks, knots, warps and split. The ends of the cables shall be suitably sealed by means of non-hygroscopic sealing. The tolerance on the Drum length shall be +/- 5%.

#### 6. MARKING

The cable shall carry the following information either stenciled on the drum or contained in a label attached to it:

- a) Reference to the Standards.
- b) Manufacturer's name.
- c) Type of cable.
- d) Voltage grade.
- e) Number of cores.
- f) Nominal cross-section area of the conductor.

Rev No.	Description	Prepared By & Date	Checked By & Date	Approved for Issue By & Date
RO	Specifications for LT ABC Conductor	Anil Sah	Niranjan Khuntia	Pourush Garg
		05/08/2020	05/08/2020	05/08/2020

TP Central Odisha Distribution Limited	 TP CENTRAL ODISHA DISTRIBUTION LIMITED	SPECIFICATION FOR LT ABC Conductor
NEG-SPEC-13		Date of Issue: 05/08/2020

- g) Length of the cable on the drum.
- h) Length of the cable per m.
- i) Marking of PO
- j) Direction of rotation of the drum.
- k) Gross mass.
- l) Country of manufacture.
- m) Year of manufacture.
- n) ISI Certification mark.

## 7. TESTS

All routine, acceptance & type tests shall be carried out in accordance with the relevant IS/IEC. All Routine/acceptance tests shall be witnessed by the purchaser/his authorized representative. All the components shall also be type tested as per the relevant standards. Following tests shall be necessarily conducted on the LT ABC cables in additions to others specified in the IS/IEC/SANS Standards.

### (A) Tests for Phase Core are as follows:

#### Type tests

- a) Tests on phase/street light Conductor
  - i) Tensile test
  - ii) Wrapping test
  - iii) Resistance test
- b) Tests on messenger Conductor
  - i) Breaking load test
  - ii) Elongation test.
  - iii) Resistance test.
- c) Physical Test for XLPE Insulation:
  - i) Tensile strength and elongation at break
  - ii) Ageing in air oven
  - iii) Hot test
  - iv) Shrinkage test
  - v) Water absorption (gravimetric)
  - vi) Carbon black:
    - 1) Content.
    - 2) Dispersion.
  - vii) Insulation resistance (Volume resistivity) test.
- d) Test for thickness insulation.
- e) High voltage test.

#### Acceptance Tests

- i) Tensile Test (for phase/street light conductor).
- ii) Wrapping Test (for phase/street light conductor).

Rev No.	Description	Prepared By & Date	Checked By & Date	Approved for Issue By & Date
RO	Specifications for LT ABC Conductor	Anil Sah	Niranjan Khuntia	Pourush Garg
		05/08/2020	05/08/2020	05/08/2020

TP Central Odisha Distribution Limited	<b>TPCODL</b>  TP CENTRAL ODISHA DISTRIBUTION LIMITED	SPECIFICATION FOR LT ABC Conductor
NEG-SPEC-13		Date of Issue: 05/08/2020

- iii) Breaking load test for messenger conductor.
- iv) Elongation test for messenger conductor.
- v) Conductor Resistance Test for messenger and phase conductor.
- vi) Test for thickness of insulation.
- vii) Hot set test for XLPE insulation.
- viii) Tensile strength and elongation at break test for insulation ..
- ix) High Voltage test
- x) Insulation resistance (Volume resistivity) test.
- xi) UV test for XLPE Insulation (black carbon content and dispersion test).

**Tests for the Messenger wire:**

- xii) Breaking load Test
- xiii) Elongation test
- xiv) Resistance test

**Routine Tests**

- i) Conductor Resistance test
- ii) High Voltage test

**Optional Test**

Bending test.

**8. TYPE TEST CERTIFICATES**

The bidder shall furnish the type test certificates of the cable for the tests as mentioned as above as per the corresponding standards. All the tests shall be conducted by CPRI/ERDA as per the relevant standards. Type test should have been conducted in certified Test Laboratories during the period not exceeding 5 years from the date of opening the bid. In the event of any discrepancy in the test reports

- i. e. any test report not acceptable or any/all type tests (including additional type tests, if any) not carried out, same shall be carried out without any cost implication to TPCODL.

**9. PRE DISPATCH INSPECTION**

The Material shall be subject to inspection by a duly authorized representative of the TPCODL. Inspection may be made at any stage 61 manufacture at the discretion of the purchaser and the equipment, if found unsatisfactory as to workmanship or material, the same is liable to rejection. Bidder shall grant free access to the places of manufacture to TPCODL's representatives at all times when the work is in progress. Inspection by the TPCODL or its authorized representatives shall not relieve the bidder of his obligation of furnishing equipment in accordance with the specifications. Material shall be dispatched

Rev No.	Description	Prepared By & Date	Checked By & Date	Approved for Issue By & Date
RO	Specifications for LT ABC Conductor	Anil Sah	Niranjan Khuntia	Pourush Garg
		05/08/2020	05/08/2020	05/08/2020



TP Central Odisha Distribution Limited	 TP CENTRAL ODISHA DISTRIBUTION LIMITED	SPECIFICATION FOR LT ABC Conductor
NEG-SPEC-13		Date of Issue: 05/08/2020

after specific MDCC (Material Dispatch Clearance Certificate) is issued by TPCODL.

Following documents shall be sent along with material

- a) Test reports
- b) MDCC issued by TPCODL
- c) Invoice in duplicate
- d) Packing list
- e) Drawings & catalogue
- f) Guarantee/ Warrantee card
- g) Delivery Challan
- h) Other Documents (as applicable).

#### 10. INSPECTION AFTER RECEIPT AT STORES

The material received at TPCODL store will be inspected for acceptance and shall be liable for rejection, if found different from the reports of the pre-dispatch inspection and one copy of the report shall be sent to Engineering & Contracts department.

#### 11. GUARANTEE

Bidder shall stand guarantee towards design, materials, workmanship & quality of process/ manufacturing of items under this contract for due and intended performance of the same, as an integrated product delivered under this contract. In the event any defect is found by the Purchaser up to a period of at least 12 months from the date of commissioning or 24 months from the date of last supplies made under the contract whichever is later, (the time scale of 12/24 months could be enhanced subject to mutual agreements). Bidder shall be liable to undertake to replace/rectify such defects at its own costs, within mutually agreed time frame, and to the entire satisfaction of the Purchaser, failing which the Purchaser will be at liberty to get it replaced/rectified at Bidder's risks and costs and recover all such expenses plus the Purchaser's own charges (@ 20% of expenses incurred), from the Bidder or from the "Security cum Performance Deposit" as the case may be.

Bidder shall further be responsible for 'free replacement' for another period of THREE years from the end of the guarantee period for any 'Latent Defects' if noticed and reported by the Purchaser.

#### 12. PACKING

The cable shall be wound on wooden drums and packed in line with requirements of IS 10418-1982. The ends of the cable shall be sealed by means of non-hygroscopic sealing material.

Bidder shall ensure that all the equipment covered under this specification shall be prepared for rail/road transport in a manner so as to protect the equipment from damage in transit.

#### 13. TENDER SAMPLE

Rev No.	Description	Prepared By & Date	Checked By & Date	Approved for Issue By & Date
RO	Specifications for LT ABC Conductor	Anil Sah	Niranjan Khuntia	Pourush Garg
		05/08/2020	05/08/2020	05/08/2020

TP Central Odisha Distribution Limited	 TP CENTRAL ODISHA DISTRIBUTION LIMITED	SPECIFICATION FOR LT ABC Conductor
NEG-SPEC-13		Date of Issue: 05/08/2020

Bidder shall submit the sample of material with the offer (in case of first supply to TPCODL).

**14. QUALITY CONTROL**

The bidder shall submit with the offer Quality assurance plan indicating the various stages of inspection, the tests and checks which will be carried out on the material of construction, components during manufacture and bought out items and fully assembled component and equipment after finishing. As part of the plan, a schedule for stage and final inspection within the parameters of the delivery schedule shall be furnished. The Purchaser's engineer or its nominated representative shall have free access to the manufacturer's/sub-supplier's works to carry out inspections.

**15. MINIMUM TESTING FACILITIES**

Bidder shall have adequate in house testing facilities for carrying out all routine tests & acceptance tests as per relevant International/ Indian standards.

**16. MANUFACTURING ACTIVITIES**

The successful bidder will have to submit the bar chart for various manufacturing activities clearly elaborating each stage, with quantity. This bar chart should be in line with the Quality assurance plan submitted with the offer. This bar chart will have to be submitted within 15 days from the release of the order.

**17. SPARES, ACCESSORIES AND TOOLS**

The bidder shall provide a list of complete set of accessories and tools required for erection and maintenance of LT ABC along with the installation procedure.

**18. DRAWINGS AND DOCUMENTS**

Following documents shall be prepared based on TPCODL specifications and statutory requirements with complete BOM and shall be submitted with the bid:

- a) Completely filled in Technical Particulars.
- b) General description of the equipment and all components including brochures.
- c) Type test Certificates
- d) Experience List.

After the after of the contract, four (4) copies of the drawings, drawn to scale, describing the equipment in detail shall be forwarded for approval and shall subsequently provide four (4) complete sets of final drawings, one of which shall be auto positive suitable for reproduction, before the dispatch of the equipment. Soft copy (Compact Disk CD) of all the drawing, GTP, test certificates shall be submitted after the final approval of the same to the purchaser

Rev No.	Description	Prepared By & Date	Checked By & Date	Approved for Issue By & Date
RO	Specifications for LT ABC Conductor	Anil Sah	Niranjan Khuntia	Pourush Garg
		05/08/2020	05/08/2020	05/08/2020

TP Central Odisha Distribution Limited	 TP CENTRAL ODISHA DISTRIBUTION LIMITED	SPECIFICATION FOR LT ABC Conductor
NEG-SPEC-13		Date of Issue: 05/08/2020

Following Drawings/Documents shall be submitted after the award of the contract

All the Documents and Drawings shall be in English Language.  
Instruction Manuals: Bidder shall furnish two (2) soft copies (CD) and four (4) hard copies of nicely bound manual (in English Language) covering erection and maintenance instructions and all relevant information pertaining to the main equipment as well as auxiliary devices.

#### 19. GTP

##### A) 4X150 +1X150 +1X16 sqmm

SI no	Description	Units	Requirement (To be Furbished by Bidder)
1	Type of cable		
2	Size of Aerial Bunched cable		
3	Rated Voltage	KV	
4	System Voltage	KV	
5	Nominal Area of Phase Conductor	mm <sup>2</sup>	
6	Nominal Area of Messenger	Mm <sup>2</sup>	
7	Phase Core & Neutral core		
8	Messenger Wire		
9	Standard length of the cable with tolerance	m	
10	Maximum conductor temperature durinQ continuous operation	deg C	
11	Maximum conductor temperature durina short circuit	deg C	
12	Phase Core RYBN insulated		
a)	Conductor		
	(i) Material		
	(ii) No. of Cores & Nominal Size	Mm <sup>2</sup>	
	(iii) Minimum number		

Rev No.	Description	Prepared By & Date	Checked By & Date	Approved for Issue By & Date
RO	Specifications for LT ABC Conductor	Anil Sah	Niranjan Khuntia	Pourush Garg
		05/08/2020	05/08/2020	05/08/2020



TP Central Odisha Distribution Limited	 TP CENTRAL ODISHA DISTRIBUTION LIMITED	SPECIFICATION FOR LT ABC Conductor
NEG-SPEC-13		Date of Issue: 05/08/2020

	of wires/Diameter		
	Max. DC Resistance at 20 deg. C	Ohm/KM	
	Shape of Conductor		
	Short Circuit current rating of conductor for 1 sec	KA	
	Continuous current rating in air at 40 DeQ.C	A	
b)	INSULATION		
	i) Material		
	ii) Nominal Thickness	Mm	
	Tolerance in Insulation Thickness	Mm	
13	Street light core		
a	Conductor		
	i) Material		
	ii) Nominal size	Mm <sup>2</sup>	
	Nominal no. of wire		
	Max DC resistance at 20 deg. C	Ohm/KM	
	Shape of conductor		
b	Insulation		
	Material		
	Nominal thickness		
	Tolerance in Insulation Thickness		
13	Earth Cum Messenger Wire		
a	Messenger wire		
	Material		
	Nominal size	Mm <sup>2</sup>	
	No. and Nominal Dia. of each strand	No./mm	
	App. Calculated Breaking Load	KN	
	Calculated Maximum resistance at 20 deqC	ohm/km	
	Shape of conductor		
	Short circuit rating for 1 sec	kA	
14	Core Identification		

Rev No.	Description	Prepared By & Date	Checked By & Date	Approved for Issue By & Date
RO	Specifications for LT ABC Conductor	Anil Sah	Niranjan Khuntia	Pourush Garg
		05/08/2020	05/08/2020	05/08/2020

TP Central Odisha Distribution Limited	 TP CENTRAL ODISHA DISTRIBUTION LIMITED	SPECIFICATION FOR LT ABC Conductor
NEG-SPEC-13		Date of Issue: 05/08/2020

15	Formation of cable		
16	Approx. weight of the messenger	Kg/Km	
17	Continuous current rating in air at 40DeQC (RYBN/MessenQer)	A	
18	Maximum conductor temperature during continuous operation (RYBN)	Deg C	
19	Maximum conductor temperature durina Short circuit (RYBN)	Deg C	
20	Short circuit rating for 1 sec	kA	
21	Standard Drum Length	Mtr	
22	Tolerance in Drum length	%	

**B) 4X70+1X70+1X16 sqMM**

Sl no	Description	Units	Requirement (To be Furbished by Bidder)
1	Type of cable		
2	Size of Aerial Bunched cable		
3	Rated Voltage	KV	
4	System Voltage	KV	
5	Nominal Area of Phase Conductor	mm <sup>2</sup>	
6	Nominal Area of Messenger	Mm <sup>2</sup>	
7	Phase Core & Neutral core		
8	Messenger Wire		
9	Standard length of the cable with tolerance	m	
10	Maximum conductor temperature durinQ continuous operation	deg C	
11	Maximum conductor temperature durina short circuit	deg C	

Rev No.	Description	Prepared By & Date	Checked By & Date	Approved for Issue By & Date
RO	Specifications for LT ABC Conductor	Anil Sah	Niranjan Khuntia	Pourush Garg
		05/08/2020	05/08/2020	05/08/2020

TP Central Odisha Distribution Limited	 TP CENTRAL ODISHA DISTRIBUTION LIMITED	SPECIFICATION FOR LT ABC Conductor
NEG-SPEC-13		Date of Issue: 05/08/2020

12	Phase Core RYBN insulated		
a)	Conductor		
	(i) Material		
	(ii) No. of Cores & Nominal Size	Mm2	
	(iii) Minimum number of wires/Diameter		
	Max. DC Resistance at 20 deg. C	Ohm/KM	
	Shape of Conductor		
	Short Circuit current rating of conductor for 1 sec	KA	
	Continuous current rating in air at 40 DeQ.C	A	
b)	INSULATION		
	i) Material		
	ii) Nominal Thickness	Mm	
	Tolerance in Insulation Thickness	Mm	
13	Street light core		
a	Conductor		
	i) Material		
	ii) Nominal size	Mm2	
	Nominal no. of wire		
	Max DC resistance at 20 deg. C	Ohm/KM	
	Shape of conductor		
b	Insulation		
	Material		
	Nominal thickness		
	Tolerance in Insulation Thickness		
14	Earth Cum Messenger Wire		
a	Messenger wire		
	Material		
	Nominal size	Mm2	
	No. and Nominal Dia. of each strand	No./mm	
	App. Calculated Breaking	KN	

Rev No.	Description	Prepared By & Date	Checked By & Date	Approved for Issue By & Date
RO	Specifications for LT ABC Conductor	Anil Sah	Niranjan Khuntia	Pourush Garg
		05/08/2020	05/08/2020	05/08/2020

TP Central Odisha Distribution Limited	 TP CENTRAL ODISHA DISTRIBUTION LIMITED	SPECIFICATION FOR LT ABC Conductor
NEG-SPEC-13		Date of Issue: 05/08/2020

	<b>Load</b>		
	<b>Calculated Maximum resistance at 20 degC</b>	<b>ohm/km</b>	
	<b>Shape of conductor</b>		
	<b>Short circuit rating for 1 sec</b>	<b>kA</b>	
15	<b>Core Identification</b>		
16	<b>Formation of cable</b>		
17	<b>Approx. weight of the messenger</b>	<b>Kg/Km</b>	
18	<b>Continuous current rating in air at 40DeQC (RYBN/MessenQer)</b>	<b>A</b>	
19	<b>Maximum conductor temperature during continuous operation (RYBN)</b>	<b>Deg C</b>	
20	<b>Maximum conductor temperature durina Short circuit (RYBN)</b>	<b>Deg C</b>	
21	<b>Short circuit rating for 1 sec</b>	<b>kA</b>	
22	<b>Standard Drum Length</b>	<b>Mtr</b>	
23	<b>Tolerance in Drum length</b>	<b>%</b>	

**20. SCHEDULE OF DEVIATIONS  
(TO BE ENCLOSED WITH TECHNICAL BID)**

**All deviations from this specification shall be set out by the Bidders, clause by Clause in this schedule. Unless specifically mentioned in this Schedule, the tender shall be deemed to confirm the purchaser's specifications:**

Rev No.	Description	Prepared By & Date	Checked By & Date	Approved for Issue By & Date
RO	Specifications for LT ABC Conductor	Anil Sah	Niranjan Khuntia	Pourush Garg
		05/08/2020	05/08/2020	05/08/2020

<b>TP Central Odisha Distribution Limited</b>	<b>TPCODL</b> <small>TP CENTRAL ODISHA DISTRIBUTION LIMITED</small>	<b>SPECIFICATION FOR LT ABC Conductor</b>
<b>NEG-SPEC-13</b>		<b>Date of Issue: 05/08/2020</b>

<b>SL no</b>	<b>Clause no</b>	<b>Details at deviation with justifications</b>

**We confirm that there are no deviations apart from those detailed above.**

**Seal of the Company:**

**Signature**

**Designation**

<b>Rev No.</b>	<b>Description</b>	<b>Prepared By &amp; Date</b>	<b>Checked By &amp; Date</b>	<b>Approved for Issue By &amp; Date</b>
RO	Specifications for LT ABC Conductor	Anil Sah	Niranjan Khuntia	Pourush Garg
		05/08/2020	05/08/2020	05/08/2020

<b>TP Central Odisha Distribution Limited</b>	<b>TPCODL</b>  TP CENTRAL ODISHA DISTRIBUTION LIMITED	<b>SPECIFICATION FOR LT Distribution box with MCCB</b>
<b>NEG-SPEC-14</b>		<b>Date of Issue: 05/08/2020</b>

**Technical Specification  
For  
LT Distribution Box with MCCB**

**TP Central Odisha Distribution Limited.  
Network Engineering Group  
2<sup>nd</sup> Floor, IDCO Tower  
Janpath, Bhubaneswar- 751022**

Rev No.	Description	Prepared By & Date	Checked By & Date	Approved for Issue By & Date
RO	Specifications for LT Distribution box with MCCB	Anil Sah	Niranjan Khuntia	Pourush Garg
		05/08/2020	05/08/2020	05/08/2020

<b>TP Central Odisha Distribution Limited</b>	 <b>TPCODL</b> <small>TP CENTRAL ODISHA DISTRIBUTION LIMITED</small>	<b>SPECIFICATION FOR LT Distribution box with MCCB</b>
<b>NEG-SPEC-14</b>		<b>Date of Issue: 05/08/2020</b>

## **CONTENTS**

1. SCOPE
2. APPLICABLE STANDARDS
3. CLIMATIC CONDITIONS OF THE INSTALLATION
4. GENERAL TECHNICAL REQUIREMENTS
5. GENERAL CONSTRUCTIONS
6. NAME PLATE & MARKING
7. TESTS
8. TYPE TEST CERTIFICATES
9. PRE-DISPATCH INSPECTION
10. INSPECTION AFTER RECEIPT AT STORES
11. GUARANTEE
12. PACKING
13. TENDER SAMPLE
14. QUALITY CONTROL
15. MINIMUM TESTING FACILITIES
16. MANUFACTURING ACTIVITIES
17. SPARES, ACCESSORIES AND TOOLS
18. DRAWINGS
19. GUARANTEED TECHNICAL PARTICULARS
20. SCHEDULE OF DEVIATIONS

Rev No.	Description	Prepared By & Date	Checked By & Date	Approved for Issue By & Date
RO	Specifications for LT Distribution box with MCCB	Anil Sah	Niranjan Khuntia	Pourush Garg
		05/08/2020	05/08/2020	05/08/2020

<b>TP Central Odisha Distribution Limited</b>	<b>TPCODL</b>  TP CENTRAL ODISHA DISTRIBUTION LIMITED	<b>SPECIFICATION FOR LT Distribution box with MCCB</b>
<b>NEG-SPEC-14</b>		<b>Date of Issue: 05/08/2020</b>

### 1. SCOPE:

This specification covers the technical requirements of design, manufacture, testing at manufacturer's works, packing; forwarding, supply and unloading at store/ site of Single and Three phase MCCBs with Distribution box of the ratings as mentioned in the specification below. The MCCBs shall be complete with all accessories for efficient and trouble free operation.

### 2. APPLICABLE STANDARDS:

The equipment covered by this specification shall confirm to the requirements stated in latest editions of relevant applicable Indian/IEC Standards and shall conform to the regulations of local statutory authorities.

- |    |   |   |   |
|----|---|---|---|
| a) | IS 13947-1-1993 / IEC<br>60947-1-1988     | : | Specification for LV Switchgear & Control gear - General Rules  |
| b) | IS 13947-2-1993 / IEC<br>60947-2-1989     | : | Specification for LV Switchgear & Control gear - Circuit Breakers   |
| c) | IEC 60529 -1989                           | : | Degree of Protection provided by Enclosures   |
| d) | IS 8623 (Pt.2)-1993 /<br>IEC 60439/2-1987 | : | Specification L.V. switchgear & control gear assemblies – Particular requirements for bus bar trunking systems (bus ways) |
| e) | IS 2551 - 1982                            | : | Danger Notice Plates  |
| f) | IEC 60664                                 | : | Insulation co-ordination within low voltage systems including clearances & creepage distances for equipment               |
| g) | IEC 61140                                 | : | Installations through door of Class-II Switchboards / Enclosures  |
| h) | IS 14772-2000                             | : | General requirements for enclosures for accessories for household and similar fixed electrical installation.              |

### 3. CLIMATIC CONDITIONS OF THE INSTALLATION:

The service conditions shall be as follows:

1. Maximum altitude above sea level 1,000m
2. Maximum ambient air temperature 50°C
3. Maximum daily average ambient air temperature 35°C
4. Minimum ambient air temperature 0°C
5. Maximum relative humidity 95%
6. Average number of thunderstorm days per annum (isokeraunic level) 70
7. Average number of rainy days per annum 120
8. Average annual rainfall 150cm
9. Earthquakes of an intensity in horizontal direction - equivalent to seismic acceleration of 0.3g
10. Earthquakes of an intensity in vertical direction - equivalent to seismic acceleration of 0.15g (g being acceleration due to gravity)
11. Wind velocity: 300 km/hr, 200 km/hr and 160 km/hr.

Environmentally, some of the regions, where the work will take place includes coastal areas, subject to high relative humidity, which can give rise to condensation. Onshore winds will frequently be salt laden. On

Rev No.	Description	Prepared By & Date	Checked By & Date	Approved for Issue By & Date
RO	Specifications for LT Distribution box with MCCB	Anil Sah 05/08/2020	Niranjan Khuntia 05/08/2020	Pourush Garg 05/08/2020



<b>TP Central Odisha Distribution Limited</b>	 TP CENTRAL ODISHA DISTRIBUTION LIMITED	<b>SPECIFICATION FOR LT Distribution box with MCCB</b>
<b>NEG-SPEC-14</b>		<b>Date of Issue: 05/08/2020</b>

occasions, the combination of salt and condensation may create pollution conditions for outdoor insulators. Some places are in heavily industrial polluted areas.

Therefore, Outdoor material and equipment shall be designed and protected for use in exposed, heavily polluted, salty, corrosive and humid coastal atmosphere

The design of equipment and accessories shall be suitable to withstand seismic forces corresponding to an acceleration of 0.1 g.

#### 4. GENERAL TECHNICAL REQUIREMENTS :

S no.	DESCRIPTION	REQUIREMENT			
1	Type of MCCB	Fixed type Manually Operated (mounted in outdoor type Distribution Box)			
2	Type of Releases	Thermal magnetic or Fully magnetic			
3	Rating (A)	40, 63 & 100A	40, 63 & 100A	160, 250 & 400 A	500 & 630 A
4	Over Load Release setting	Fixed	0.8-1 In	0.8-1 In	0.8-1 In
5	No. of Poles	Single	Three	Three	Three
6	Rated Voltage	230V	415V	415V	415V
7	Rated ultimate short circuit breaking capacity (Icu)	10kA rms	25 kA rms	35kA rms	50kA rms
8	Rated service short circuit breaking capacity (Ics)	50% of Icu	100% of Icu	100% of Icu	100% of Icu
9	Utilization Category	A			
10	Rated Insulation Voltage	690 V			
11	Rated Impulse withstand voltage	8 kVP			
12	Material of Busbar	Aluminium			
13	Max. current Density of busbar	1.00 A/mm <sup>2</sup> - should be compliant to Rated Breaking Capacity of MCCB			
14	Max. Permissible temp. rise	80°C at terminals with an ambient temperature not exceeding 40°C			
15	Min. Clearance b/w phases	25 mm			
16	Min. Clearance b/w phase to earth	20 mm			
17	Degree of Protection of enclosure	IP 66			

Rev No.	Description	Prepared By & Date	Checked By & Date	Approved for Issue By & Date
RO	Specifications for LT Distribution box with MCCB	Anil Sah 05/08/2020	Niranjan Khuntia 05/08/2020	Pourush Garg 05/08/2020

<b>TP Central Odisha Distribution Limited</b>	 <b>TPCODL</b> <small>TP CENTRAL ODISHA DISTRIBUTION LIMITED</small>	<b>SPECIFICATION FOR LT Distribution box with MCCB</b>
<b>NEG-SPEC-14</b>		<b>Date of Issue: 05/08/2020</b>

## GENERAL CONSTRUCTION

### 5.1 ENCLOSURE OF DISTRIBUTION BOX

The MCCB shall be housed in an enclosure made of 2mm thick sheet steel and shall be dust and vermin proof. The enclosure shall be provided with robust construction & an overall canopy on top for smooth draining of rain water. The enclosure shall be suitable for outdoor installation with IP 66 Degree of Protection. The MCCB mounted inside the enclosure shall be provided with extended insulated Aluminum links for tapping off multiple outgoing connections, designed for use on 230V, 1-phase and 415V, 3-phase, 4wire, 50Hz supply system. The pockets of aluminum links shall be sealed properly to avoid ingress of the moisture.

The enclosure shall have single door arrangement with concealed hinges so that door is not easily removable to avoid pilferage. It shall be so designed that when it is opened and other protective means, if any are removed, all parts requiring access for installation and maintenance, as prescribed by the manufacturer, are readily accessible. Sufficient space shall be provided inside the enclosure for the accommodation of external conductors from their point of entry into the enclosure to the terminals to ensure adequate connection. All parts shall be manufactured in accordance with latest relevant IS / IEC Standards. In case of equipment with conductive enclosures, means shall be provided if necessary to ensure electrical continuity between exposed conductive parts of the equipment and the metal sheathing of connecting conductors. The removable parts of the enclosure shall be firmly secured to the fixed parts by a device such that they cannot be accidentally loosened or detached owing to the effects of operation of the equipment or vibrations. Enclosures shall be so designed as to allow the covers to be opened with the use of tools, but means shall be provided to prevent loss of the fastening devices.

Doors of all MCCB enclosure shall have one panel type lock & one padlock at the front of the door. Single Master key shall be provided for all door locks. For mounting the enclosure, the mounting clamps shall be on top & side of the enclosure and shall be of minimum thickness of 5mm. All the hardware used shall be hot dipped Galvanized or Electro-Zinc plated.

For 3-Phase MCCB boxes the phase sequence shall be B-Y-R-N from the left, when viewed from the front of the MCCB box. However, for 1-Phase boxes (which are to be mounted back to back with the transformer), the configuration shall be Ph-N from the left, when viewed from the front of the MCCB. The mounting arrangement of MCCB shall such that for a given rating of MCCB, same rating MCCB of any TPCODL approved manufacturer can be installed / replaced easily at site without making any changes in bus bar arrangement.

All the bus-bars shall be of Electrolytic grade Aluminum duly sleeved with heat shrinkable PVC sleeves with 1.1kV insulation. Bus bar sizes shall be chosen by considering all the safety factors and area reduced due to hole cut on the bus. The hole sizes on the bus bar shall be provided in line with the lug sizes used in TPCODL system by maintaining appropriate clearance between all lugs for proper cable termination. The outgoing three phase bus bars with neutral shall be horizontally aligned & suitable for providing adequate connections. The distance from gland plate to bottom bus bar (neutral) shall be indicated in the drawing. Non hygroscopic, non-combustible type Bus bar insulators of material such as SMC/DMC shall be used. A minimum 2 Nos. of Bus bars insulators (At both ends of phase & neutral bus) shall be used in all the MCCB boxes so that the bus bars shall be rigidly mounted. Panel Builder shall furnish a type-test certificate from CPRI/ERDA in support of Bus-bars system of MCCB Distribution Box, having short-circuit withstand capacity equal to respective MCCB short-ckt. Breaking capacity used in that Distribution Box. A Cable box shall be provided at the back side of the MCCB box for incoming cable connection.

Rev No.	Description	Prepared By & Date	Checked By & Date	Approved for Issue By & Date
RO	Specifications for LT Distribution box with MCCB	Anil Sah	Niranjan Khuntia	Pourush Garg
		05/08/2020	05/08/2020	05/08/2020

<b>TP Central Odisha Distribution Limited</b>	 <b>TPCODL</b> TP CENTRAL ODISHA DISTRIBUTION LIMITED	<b>SPECIFICATION FOR LT Distribution box with MCCB</b>
<b>NEG-SPEC-14</b>		<b>Date of Issue: 05/08/2020</b>

### 5.2 MCCBs :

MCCBs shall comply to latest standards of IS-13947-2 / IEC-60947-2. These MCCBs shall have high Mechanical & Electrical Endurance. All 3-pole MCCBs shall be suitable for 'ISOLATION' with positive contact indication for safety of Operating Personnel. Each current path and operating contact system of 3-pole MCCBs shall be of encapsulated design with double break contacts on incoming and outgoing side of the current path. These MCCBs shall be of Current Limiting design to reduce impact of thermal stresses on Cables and down the line Electrical Distribution system, while opening on high fault currents.

All MCCBs shall have well defined and identified ON, OFF, & Trip Positions marked on front face of the MCCB in accordance with Indian and International standards. MCCBs shall have a 'Push to Trip' test button on front face to test healthiness of Trip unit. Phase Barriers shall be provided on all 3-pole MCCBs to prevent travel of arc between phases during any short circuit fault, for maximum insulation between phases at power terminals and to maximize creepage distance between phases. MCCBs shall also be provided with suitable spreaders for easy termination of Aluminium bus bar links on them so as to save MCCBs from any damage. Phase Barriers & Spreaders shall be original part of approved MCCB makes. Test report to be provided of material used for phase barriers and spreader from MCCB supplier. Local similar phase barriers & spreaders shall not be accepted for superior connections between MCCB terminal with Distribution Box bus bars.

### 5.3 GLAND PLATES :

Detachable CRCA sheet steel gland plates of 3mm thickness shall be provided for accommodating I/C & O/G cables. Rubber seal for all the holes shall be provided separately. The gland plate for each MCCB DB shall be provided with holes (knock out type) suitable for the brass glands in accordance with XLPE insulated, armoured cables for I/C & O/G mentioned in the table below. Details of the no. of holes that should be drilled in the gland plate for particular ratings of MCCB Distribution Box along with incoming and outgoing cables sizes are as given below and shall be adhered to by the supplier of the MCCB DBs.

<b>Knockout type openings required in MCCB Box</b>												
S.no.	TRF. Rating	MCCB Rating	Incoming Cables		Outgoing cables/Service lines to consumers from MCCB					Total no. of openings in incoming base plate	Total no. of openings in outgoing base plate	
			4Cx150 sq mm	4Cx300 sq mm	2Cx16 sq mm (1ph Only)	2Cx25 sq mm (1ph Only)	4Cx25 sq mm	4Cx95 sq mm	4Cx150 sq mm		3-Phase	1-Phase
1	10kVA - SP	40A, 10kA - SP	Directly mounted on Trf.		4	0	0	0	0	Directly mounted on Trf.	4	0
2	16kVA - SP	63A, 10kA - SP	Directly mounted on Trf.		4	0	0	0	0		Directly mounted on Trf.	4
3	25kVA - SP	100A, 10kA - SP	Directly mounted on Trf.		4	2	0	0	0	Directly mounted on Trf.	6	0
4	25kVA - TP	40A, 35kA - TP	Directly mounted on Trf.		4	2	2	0	0	Directly mounted on Trf.	6	2

Rev No.	Description	Prepared By & Date	Checked By & Date	Approved for Issue By & Date
RO	Specifications for LT Distribution box with MCCB	Anil Sah 05/08/2020	Niranjan Khuntia 05/08/2020	Pourush Garg 05/08/2020

<b>TP Central Odisha Distribution Limited</b>	<b>TPCODL</b> <small>TP CENTRAL ODISHA DISTRIBUTION LIMITED</small>	<b>SPECIFICATION FOR LT Distribution box with MCCB</b>
<b>NEG-SPEC-14</b>		<b>Date of Issue: 05/08/2020</b>

5	63kVA - TP	100A, 35kA - TP	1	0	0	0	3	2	0	1	0	5
6	100kVA - TP	160A, 35kA - TP	1	0	0	0	4	2	0	1	0	6
7	160kVA - TP	250A, 35kA - TP	0	1	0	0	2	3	0	1	0	5
8	250kVA - TP	400A, 35kA - TP	2	0	0	0	0	4	1	2	0	5
9	315kVA - TP	500A, 50kA - TP	0	2	0	0	0	3	2	2	0	5
10	400kVA - TP	630A, 50kA - TP	0	2	0	0	0	4	3	2	0	7

#### 5.4 TERMINALS & CONNECTIONS :

Current carrying parts shall have the necessary mechanical strength and current carrying capacity for their intended use. All parts of terminals which maintain contact and carry current shall be of metal having adequate mechanical strength. Terminal connections shall be such that the conductors may be connected by means of screws, bolts, spring washers or other equivalent means so as to ensure that the necessary contact pressure is maintained. Standard sizes of bolts, screws, pipe and other fittings shall be used and number of sizes to be kept minimum. Terminals shall be so constructed that the conductors can be clamped between suitable surfaces without any significant damage either to conductors or terminals. Terminals shall not allow the conductors to be displaced or be displaced themselves in a manner detrimental to the operation of equipment and the insulation voltage shall not be reduced below the rated values. Terminals for connection to external conductors shall be readily accessible during installation. The number of termination points on the bus bar shall be in accordance with the number of outgoing conductors as stated in the table above.

All mechanism shall be made of such material as to prevent corrosion due to sticking of dust. All connections and contacts shall be of ample cross-section and surface area for carrying continuously the specified current without undue heating and shall be secured rigidly & locked in position. The manufacturer shall state the type (rigid/ stranded/ flexible), the minimum and the maximum cross sections of conductors for which the terminal is suitable and, if applicable, the number of conductors simultaneously connectable to the terminal. The incoming cable shall be terminated at back side of the bottom of the MCCB distribution box and outgoing cable shall be terminated from front of the bottom of the box.

#### 5.5 INSULATION SUPPORT :

The bidder shall use fire retardant material (not Bakelite) for insulation and seal the gap near the bus-bars with sealing agent, to prevent the inrush of dust and moisture from the back side of enclosure. Phase barrier of the same material shall also be provided. If, in order to provide safety to the operating personnel, Bakelite separator shall be provided in front of incoming bus-bars.

#### 5.6 PROTECTIVE MEASURES :

The design shall incorporate every reasonable precaution and provision for the safety of all those concerned in the operation and maintenance so that there is no possibility of the operator experiencing a

Rev No.	Description	Prepared By & Date	Checked By & Date	Approved for Issue By & Date
RO	Specifications for LT Distribution box with MCCB	Anil Sah 05/08/2020	Niranjan Khuntia 05/08/2020	Pourush Garg 05/08/2020

<b>TP Central Odisha Distribution Limited</b>	<b>TPCODL</b>  TP CENTRAL ODISHA DISTRIBUTION LIMITED	<b>SPECIFICATION FOR LT Distribution box with MCCB</b>
<b>NEG-SPEC-14</b>		<b>Date of Issue: 05/08/2020</b>

shock during normal operation. All apparatus, connections and cabling shall be designed / arranged to minimize risks of fire and any damage which might cause in the event of fire.

Bakelite impregnated / non impregnated should not be used internally or externally. All apparatus shall be so designed and constructed as to obviate the risks or short circuits of the live parts by lizards / rodents.

When the operating person is opening the door, at any circumstances he should not be able to access the live bus directly. Insulated barriers shall be provided on live incoming side terminals of MCCB, so as to ensure that no accidental contact is possible. Each MCCB box shall be provided with a Danger Plate of Aluminium sheet embossed / engraved or Screen Printed on Enclosure, with 415V AC and danger mark in English and Hindi also effectively secured..

#### 5.7 PROTECTIVE EARTHING :

The fixed parts of a metal enclosure shall be electrically connected to the other exposed conductive parts of the equipment and connected to a terminal which enables them to be earthed or connected to a protective conductor. The exposed conductive parts (e.g. chassis, framework and fixed parts of metal enclosures) other than those which cannot constitute a danger shall be electrically interconnected and connected to a protective earth terminal for connection to an earth electrode or to an external protective conductor. Under no circumstances shall a removable metal part of the enclosure be insulated from the part carrying the earth terminal when the removable part is in place.

The MCCB Box shall be provided with an Aluminium Earth bus suitable for the Rated short circuit current of the breaker. Two nos. body earthing studs shall be provided on side of boxes for body earthing. Provision of one other stud shall be provided for neutral earthing in those boxes which are directly mounted on the transformer. Earthing bolt should be welded in the box and not to be fixed. Neutral earthing should be separated from body with separate studs. The earth terminals/ studs shall be of a suitable size to accommodate the earth conductor and shall be corrosion protected. The earth terminals shall be identified by means of the earthing sign marked in a legible and indelible manner on or adjacent terminals. The earthing studs shall be welded from inside the enclosure and shall be covered from top so as to prevent access for theft. The protective earth terminal shall be readily accessible and so placed that the connection of the equipment to the earth electrode or to the protective conductor is maintained when the cover or any other removable part is removed.

#### 5.8 PAINTING:

The paint shall be applied on clean, dry surface under suitable atmospheric conditions by seven tank process followed by powder coating. The paint shade shall be RAL 7032 with thickness of the powder coating not less than 70 microns.

#### 6. NAMEPLATE & MARKINGS :

All the components and operating devices of the MCCB and Distribution Box shall be provided with durable and legible nameplates OR Screen printed, containing all technical parameters. MCCB and Distribution Box name plate & markings shall be in accordance with IS-13947-2 / IEC-60947-2 along with the following information:

- i) Manufacturer's Name
- ii) Type designation & serial no.
- iii) Reference No. of the relevant standard

Rev No.	Description	Prepared By & Date	Checked By & Date	Approved for Issue By & Date
RO	Specifications for LT Distribution box with MCCB	Anil Sah	Niranjan Khuntia	Pourush Garg
		05/08/2020	05/08/2020	05/08/2020



<b>TP Central Odisha Distribution Limited</b>	<b>TPCODL</b>  TP CENTRAL ODISHA DISTRIBUTION LIMITED	<b>SPECIFICATION FOR LT Distribution box with MCCB</b>
<b>NEG-SPEC-14</b>		<b>Date of Issue: 05/08/2020</b>

- iv) Utilization category
- v) Rated Operational Voltage
- vi) Rated current
- vii) Rated frequency
- viii) Rated service short circuit breaking capacity (Ics)
- ix) Rated ultimate short circuit breaking capacity (Icu)
- x) Line and load terminals
- xi) Neutral pole terminals in MCCB DB
- xii) Protective earth terminal markings on MCCB DB
- xiii) Indication of Open and Closed positions on MCCB
- xiv) Terminal Marking

The Name Plate on MCCB Distribution Box shall be embossed OR Screen Printed with PO NO., Date, "PROPERTY OF TPCODL," "MATERIAL CODE No.," and name of Manufacturer. A danger plate of appropriate size shall be provided on the enclosure OR Screen Printed. Apart from this, 'Suitable for \_\_\_\_\_ kVA Transformer shall be also printed in order to identify as to which rating of transformer the corresponding MCCB box is designed for. Also 'No current-call center no- 011-66404040' shall be dully printed on the front of the MCCB box.

## 7. TESTS :

All routine, acceptance & type tests shall be carried out in accordance with the relevant IS / IEC Standards. Routine / Acceptance tests may be witnessed by the purchaser / his authorized representative, if so desired. All the components as applicable shall be type tested as per the relevant standards. Following tests shall be necessarily conducted on the equipment in addition to the others specified in IS / IEC.

### Type Tests for MCCBs :

- a) Tripping Limits & Characteristics
- b) Operational & Overload Performance Capability
- c) Short Circuit Breaking/Making capacities
- d) Dielectric Properties test

### Type Tests for Enclosure :

- a) Temperature Rise Test
- b) Dielectric Properties test
- c) Degree of Protection of enclosure.

### Routine Tests for MCCB:

- a) Mechanical & electrical Operation
- b) Calibration of Releases.
- c) Continuity of circuit.
- d) Dielectric withstand.

### Routine Tests for Enclosure:

- a) Dielectric tests
- b) Verification of clearances
- c) Dimensional Checks

Rev No.	Description	Prepared By & Date	Checked By & Date	Approved for Issue By & Date
RO	Specifications for LT Distribution box with MCCB	Anil Sah	Niranjan Khuntia	Pourush Garg
		05/08/2020	05/08/2020	05/08/2020

<b>TP Central Odisha Distribution Limited</b>	 TP CENTRAL ODISHA DISTRIBUTION LIMITED	<b>SPECIFICATION FOR LT Distribution box with MCCB</b>
<b>NEG-SPEC-14</b>		<b>Date of Issue: 05/08/2020</b>

**8. TYPE TESTS CERTIFICATES :**

The bidder shall furnish the type test certificates for the tests as mentioned above as per the corresponding standards. All the tests shall be conducted at CPRI / ERDA accredited test Labs, as per the relevant standards. Type test should have been conducted in certified Test Laboratories during the period not exceeding 5 years from the date of opening the bid. However, Type Test certificated which are older than 5 years from date of bid opening, may be accepted as a special case, provided there is no change in corresponding IS / IEC standards or MCCB design. In the event of any discrepancy in the test reports i.e. any test report not acceptable or any/all type tests (including additional type tests, if any) not carried out, same shall be carried out without any cost implication to TPCODL.

**9. PRE-DISPATCH INSPECTION :**

Equipment shall be subject to inspection by a duly authorized representative of the TPCODL. Inspection may be made at any stage of manufacture at the discretion of the purchaser and the equipment, if found unsatisfactory as to workmanship or material, the same is liable to rejection. Bidder shall grant free access to the places of manufacture to TPCODL's representatives at all times when the work is in progress. Inspection by the TPCODL or its authorized representatives shall not relieve the bidder of his obligation of furnishing equipment in accordance with the specifications. Material shall be dispatched after specific MDCC (Material Dispatch Clearance Certificate) is issued by TPCODL.

Following documents shall be sent along with material

- a) Test reports
- b) MDCC issued by TPCODL
- c) Invoice in duplicate
- d) Packing list
- e) Drawings & catalogue
- f) Guarantee / Warrantee card
- g) Delivery Challan
- h) Other Documents (as applicable)

**10. INSPECTION AFTER RECEIPT AT STORE :**

The material received at TPCODL, Odisha store will be inspected for acceptance and shall be liable for rejection, if found different from the reports of the pre-dispatch inspection and one copy of the report shall be sent to Project Engineering department

**11. GUARANTEE :**

Bidder shall stand guarantee towards design, materials, workmanship & quality of process / manufacturing of items under this contract for due and intended performance of the same, as an integrated product delivered under this contract. In the event any defect is found by the Company up to a period of at least 12 months from the date of commissioning or 24 months from the date of supply of each Lot made under the contract whichever is earlier, (the time scale of 12/24 months could be enhanced subject to mutual agreements) Associates shall be liable to undertake to replace/rectify such defects at its own costs, within mutually agreed time frame, and to the entire satisfaction of the Company, failing which the Company will be at liberty to get it replaced/rectified at Associate's risks and costs and recover all such expenses plus the Company's own charges (@ 20% of expenses incurred), from the Associate or from the "Security cum Performance Deposit" as the case may be.

Rev No.	Description	Prepared By & Date	Checked By & Date	Approved for Issue By & Date
RO	Specifications for LT Distribution box with MCCB	Anil Sah	Niranjan Khuntia	Pourush Garg
		05/08/2020	05/08/2020	05/08/2020

<b>TP Central Odisha Distribution Limited</b>	<b>TPCODL</b>  TP CENTRAL ODISHA DISTRIBUTION LIMITED	<b>SPECIFICATION FOR LT Distribution box with MCCB</b>
<b>NEG-SPEC-14</b>		<b>Date of Issue: 05/08/2020</b>

Bidder shall further be responsible for 'free replacement' for another period of THREE years from the end of the guarantee period for any 'Latent Defects' if noticed and reported by the Company.

**12. PACKING :**

Bidder shall ensure that all equipment covered under this specification shall be prepared for rail/road transport (local equipment) and be packed in such a manner as to protect it from damage in transit.

**13. TENDER SAMPLE :**

Not applicable

**14. QUALITY CONTROL :**

The bidder shall submit with the offer Quality Assurance Plan indicating the various stages of inspection, the tests and checks which will be carried out on the material of construction, components during manufacture and bought out items and fully assembled component and equipment after finishing. As part of the plan, a schedule for stage and final inspection within the parameters of the delivery schedule shall be furnished. The Purchaser's/ Consultant's engineer shall have free access to the manufacturer's/sub-supplier's works to carry out inspections.

**15. MINIMUM TESTING FACILITIES :**

Bidder shall have adequate in house testing facilities for carrying out all routine tests & acceptance tests as per relevant International / Indian standards.

**16. MANUFACTURING ACTIVITIES :**

The successful bidder will have to submit the bar chart for various manufacturing activities clearly elaborating each stage, with quantity. This bar chart should be in line with the Quality assurance plan submitted with the offer. This bar chart will have to be submitted within 15 days from the release of the order.

**17. SPARES, ACCESSORIES & TOOLS :**

Bidder shall provide a list of recommended spares with quantity and unit prices for 3 years of operation after commissioning. The bidder shall provide a list of complete set of accessories and tools required for erection & maintenance along with the installation procedure.

**18. DRAWINGS :**

Following drawings & Documents shall be prepared based on TPCODL specifications and statutory requirements and shall be submitted with the bid:

- a) Completely filled-in Guaranteed Technical Parameters.
- b) General description of the equipment and all components including brochures
- c) General arrangement drawings
- d) Single Line Diagram
- e) Bill of material
- f) Type Test Certificates
- g) Experience List
- h) Foundation fixing drawings.
- i) Manufacturing schedule and test schedule

Rev No.	Description	Prepared By & Date	Checked By & Date	Approved for Issue By & Date
RO	Specifications for LT Distribution box with MCCB	Anil Sah 05/08/2020	Niranjan Khuntia 05/08/2020	Pourush Garg 05/08/2020



<b>TP Central Odisha Distribution Limited</b>	 TP CENTRAL ODISHA DISTRIBUTION LIMITED	<b>SPECIFICATION FOR LT Distribution box with MCCB</b>
<b>NEG-SPEC-14</b>		<b>Date of Issue: 05/08/2020</b>

Drawings/documents to be submitted after the award of the contract:

S. No.	Description	For Approval	For Review Information	Final Submission
1	Technical Parameters	√		√
2	General Arrangement drawings	√		√
3	Dimensional drawings	√		√
4	Schematic Diagram	√		√
5	Bill of Material	√		√
6	Foundation Plan/ Mounting details	√		√
7	Manual/Catalogues/drawings for ACB		√	
8	Installation Instructions		√	√
9	Instruction for Use		√	√
10	Transport/ Shipping dimension drawing		√	√
11	QA & QC Plan	√	√	√
12	Routine, Acceptance and Type Test Certificates	√	√	√

Bidder shall subsequently provide four (4) complete sets of final drawings, one of which shall be auto positive suitable for reproduction, before the dispatch of the equipment. Soft copy (Compact Disk CD) of all the drawing, GTP, Test certificates shall be submitted after the final approval of the same to TPCODL.

All the documents & drawings shall be in English language.

Instruction Manuals: Bidder shall furnish two softcopies (CD) and four (4) hard copies of nicely bound manuals (In English language) covering erection and maintenance instructions and all relevant information and drawings pertaining to the main equipment as well as auxiliary devices.

Rev No.	Description	Prepared By & Date	Checked By & Date	Approved for Issue By & Date
RO	Specifications for LT Distribution box with MCCB	Anil Sah	Niranjan Khuntia	Pourush Garg
		05/08/2020	05/08/2020	05/08/2020

<b>TP Central Odisha Distribution Limited</b>	 <b>TPCODL</b> <small>TP CENTRAL ODISHA DISTRIBUTION LIMITED</small>	<b>SPECIFICATION FOR LT Distribution box with MCCB</b>
<b>NEG-SPEC-14</b>		<b>Date of Issue: 05/08/2020</b>

### 19. GUARANTEED TECHNICAL PARTICULARS

S.No.	Particulars	Units	As furnished by vendor
<b>A</b>	<b>MCCBs</b>		
1	Type of MCCB		
2	Type of releases		
3	Make of MCCB offered	Nos.	
4	Rated Current	A	
5	Rated Operational Voltage	V AC	
6	Rated Insulation Voltage(Ui)	V	
7	No. of Poles	Nos.	
8	Utilization Category	A	
9	Rated Impulse- withstand voltage (U imp)	kV	
10	Rated Ultimate Short Ckt. Breaking capacity : Icu (kA rms)	kA	
11	Rated Service Short Ckt. Breaking capacity : Ics (kA rms) - 100 % of Icu	kA	
12	Overload release setting	%	
13	Typical Opening Time	m.sec	
14	Typical Closing Time	m.sec	
15	Electrical and Mechanical Operating cycles		
16	Spreaders & Phase Barriers	Yes	
<b>B</b>	<b>Distribution Box</b>		
17	Material of Bus bar		
18	Minimum Current Density of bus bar	A/mm <sup>2</sup>	
19	Max. permissible temperature rise		
20	Min. Clearance between phases	mm	
21	Min. Clearance between phase to earth	mm	
22	Terminal shrouds		
23	Degree of Protection for Enclosure	IP 66	
24	Overall Dimensions	mm	

Rev No.	Description	Prepared By & Date	Checked By & Date	Approved for Issue By & Date
RO	Specifications for LT Distribution box with MCCB	Anil Sah	Niranjan Khuntia	Pourush Garg
		05/08/2020	05/08/2020	05/08/2020

<b>TP Central Odisha Distribution Limited</b>	 <b>TPCODL</b> <small>TP CENTRAL ODISHA DISTRIBUTION LIMITED</small>	<b>SPECIFICATION FOR LT Distribution box with MCCB</b>
<b>NEG-SPEC-14</b>		<b>Date of Issue: 05/08/2020</b>

**20. SCHEDULES OF DEVIATIONS:**

The Bidders shall set out all deviations from this specification, Clause by Clause in this schedule. Unless **specifically** mentioned in this schedule, the tender shall be deemed to confirm the purchaser's specifications.

**SCHEDULE OF DEVIATIONS**

**(TO BE ENCLOSED WITH TECHNICAL BID)**

All deviations from this specification shall be set out by the Bidders, clause by Clause in this schedule. Unless specifically mentioned in this Schedule, the tender shall be deemed to confirm the purchaser's specifications:

S.No.	Clause No.	Details of deviation with justifications

We confirm that there are no deviations apart from those detailed above.

Seal of the Company:

Signature

Designation

Rev No.	Description	Prepared By & Date	Checked By & Date	Approved for Issue By & Date
RO	Specifications for LT Distribution box with MCCB	Anil Sah	Niranjan Khuntia	Pourush Garg
		05/08/2020	05/08/2020	05/08/2020

TP Central Odisha Distribution Limited	 TP CENTRAL ODISHA DISTRIBUTION LIMITED	Specification for 11KV / 33KV LA with Porcelain Polymer insulator
NEG-SPEC-11		Date of Issue: 05/08/2020

**Technical Specification**  
**For**  
**11KV / 33KV LA with Porcelain Polymer insulator**

**TP Central Odisha Distribution Limited.**  
**Network Engineering Group**  
**2<sup>nd</sup> Floor, IDCO Tower**  
**Janpath, Bhubaneswar- 751022**

Rev No.	Description	Prepared By & Date	Checked By & Date	Approved for Issue By & Date
R0	Specification for 11KV / 33KV LA with Porcelain Polymer insulator	Suchismita Nayak	Niranjan Khuntia	Pourush Garg
		05/08/2020	05/08/2020	05/08/2020

<b>TP Central Odisha Distribution Limited</b>		<b>Specification for 11KV / 33KV LA with Porcelain Polymer insulator</b>
<b>NEG-SPEC-11</b>	<b>TP CENTRAL ODISHA DISTRIBUTION LIMITED</b>	<b>Date of Issue: 05/08/2020</b>

## CONTENTS

- 1.0 SCOPE
- 2.0 APPLICABLE STANDARDS
- 3.0 CLIMATIC CONDITIONS OF THE INSTALLATION
- 4.0 GENERAL TECHNICAL REQUIREMENTS
- 5.0 GENERAL CONSTRUCTIONS
- 6.0 NAME PLATE AND MARKING
- 7.0 TESTS
- 8.0 TYPE TEST CERTIFICATES
- 9.0 PRE-DESPATCH INSPECTION
- 10.0 INSPECTION AFTER RECEIPT AT STORE
- 11.0 GUARANTEE
- 12.0 PACKING
- 13.0 TENDER SAMPLE
- 14.0 TRAINING
- 15.0 QUALITY CONTROL
- 16.0 MINIMUM TESTING FACILITIES
- 17.0 MANUFACTURING ACTIVITIES
- 18.0 SPARES, ACCESSORIES AND TOOLS
- 19.0 DRAWING AND DOCUMENTS
- 20.0 GURANTEED TECHNICAL PARTICULARS
- 21.0 SCHEDULE OF DEVIATIONS

Rev No.	Description	Prepared By & Date	Checked By & Date	Approved for Issue By & Date
R0	Specification for 11KV / 33KV LA with Porcelain Polymer insulator	Suchismita Nayak	Niranjan Khuntia	Pourush Garg
		05/08/2020	05/08/2020	05/08/2020

<b>TP Central Odisha Distribution Limited</b>		<b>Specification for 11KV / 33KV LA with Porcelain Polymer insulator</b>
<b>NEG-SPEC-11</b>	<b>TP CENTRAL ODISHA DISTRIBUTION LIMITED</b>	<b>Date of Issue: 05/08/2020</b>

<b>1.0</b>	<b>SCOPE</b>	<ol style="list-style-type: none"> <li>This specification covers the technical requirements of design, manufacture, testing at manufacturer's works, packing, forwarding, supply and unloading of 9 kV,10kA, DH class and SM class Lightning Arrester at site/stores complete with all accessories for efficient and trouble free-operation. The specific requirements are covered in the enclosed technical data sheet.</li> <li>The material shall be complete with all components and accessories, which are necessary or usual for their efficient performance and trouble free operation under the various operating and atmospheric conditions specified in clause no. 3</li> <li>Such of the parts that may have not been specifically included, but otherwise form part of the Lightning arrester as per standard trade and/or professional practice and/or are necessary for proper operation, will be deemed to be also included in this specification. The successful bidder shall not be eligible for any extra charges for such accessories etc. notwithstanding the fact that at the time of an initial offer bidder had segregated such items and quoted for them separately.</li> </ol>														
<b>2.0</b>	<b>APPLICABLE STANDARDS</b>	<p>The equipment ( and the materials used ) covered by this specification shall unless otherwise stated, be designed, manufactured and tested in accordance with the latest editions of the following Indian standards &amp; other relevant standards for components, BEE &amp; CEA guidelines with latest amendment from time to time, thereof, some of which are listed below:</p> <table border="1"> <thead> <tr> <th>Indian Standards ( IS /IEC</th> <th>Title</th> </tr> </thead> <tbody> <tr> <td>IS-3070:1993 (Part-3)</td> <td>Specification for Lightning arresters for alternating current system.</td> </tr> <tr> <td>IS-4759:1996 Reaffirmed 2006</td> <td>Hot dip-zinc-coating on structural steel and other allied products.</td> </tr> <tr> <td>IS-2633:1986 Reaffirmed 2006</td> <td>Method for testing uniformity of coating on zinc coated particles.</td> </tr> <tr> <td>IS-6209:1982 Reaffirmed 2006</td> <td>Method of Partial Discharge Measurement</td> </tr> <tr> <td>IS:6745:19824 Reaffirmed 2006</td> <td>Method for determination of mass of zinc coating on zinc coated iron and steel articles.</td> </tr> <tr> <td>IEC 60099-4 :2014 ed 03</td> <td>Surge arrester without gap for AC System.</td> </tr> </tbody> </table> <p><i>*In case of any conflict on any technical particular in the specification, the stricter requirement mentioned in the relevant standard shall be valid.</i></p>	Indian Standards ( IS /IEC	Title	IS-3070:1993 (Part-3)	Specification for Lightning arresters for alternating current system.	IS-4759:1996 Reaffirmed 2006	Hot dip-zinc-coating on structural steel and other allied products.	IS-2633:1986 Reaffirmed 2006	Method for testing uniformity of coating on zinc coated particles.	IS-6209:1982 Reaffirmed 2006	Method of Partial Discharge Measurement	IS:6745:19824 Reaffirmed 2006	Method for determination of mass of zinc coating on zinc coated iron and steel articles.	IEC 60099-4 :2014 ed 03	Surge arrester without gap for AC System.
Indian Standards ( IS /IEC	Title															
IS-3070:1993 (Part-3)	Specification for Lightning arresters for alternating current system.															
IS-4759:1996 Reaffirmed 2006	Hot dip-zinc-coating on structural steel and other allied products.															
IS-2633:1986 Reaffirmed 2006	Method for testing uniformity of coating on zinc coated particles.															
IS-6209:1982 Reaffirmed 2006	Method of Partial Discharge Measurement															
IS:6745:19824 Reaffirmed 2006	Method for determination of mass of zinc coating on zinc coated iron and steel articles.															
IEC 60099-4 :2014 ed 03	Surge arrester without gap for AC System.															

Rev No.	Description	Prepared By & Date	Checked By & Date	Approved for Issue By & Date
R0	Specification for 11KV / 33KV LA with Porcelain Polymer insulator	Suchismita Nayak	Niranjan Khuntia	Pourush Garg
		05/08/2020	05/08/2020	05/08/2020

<b>TP Central Odisha Distribution Limited</b>		<b>Specification for 11KV / 33KV LA with Porcelain Polymer insulator</b>
<b>NEG-SPEC-11</b>	<b>TP CENTRAL ODISHA DISTRIBUTION LIMITED</b>	<b>Date of Issue: 05/08/2020</b>

<b>3.0</b>	<b>CLIMATIC CONDITIONS OF THE INSTALLATION</b>	<p>The material shall be suitable for following climatic conditions,</p> <ol style="list-style-type: none"> <li>1. Maximum altitude above sea level 1,000m</li> <li>2. Maximum ambient air temperature 50°C</li> <li>3. Maximum daily average ambient air temperature <b>35°C</b></li> <li>4. Minimum ambient air temperature 0°C</li> <li>5. Maximum relative humidity 95%</li> <li>6. Average number of thunderstorm days per annum (isokeraunic level) <b>70</b></li> <li>7. Average number of rainy days per annum <b>120</b></li> <li>8. Average annual rainfall <b>150cm</b></li> <li>9. Earthquakes of an intensity in horizontal direction - equivalent to seismic acceleration of 0.3g</li> <li>10. Earthquakes of an intensity in vertical direction - equivalent to seismic acceleration of 0.15g (g being acceleration due to gravity)</li> <li>11. Wind velocity: 300 km/hr, 200 km/hr and 160 km/hr.</li> </ol> <p>Environmentally, some of the regions, where the work will take place includes coastal areas, subject to high relative humidity, which can give rise to condensation. Onshore winds will frequently be salt laden. On occasions, the combination of salt and condensation may create pollution conditions for outdoor insulators. Some places are in heavily industrial polluted areas.</p> <p>Therefore, Outdoor material and equipment shall be designed and protected for use in exposed, heavily polluted, salty, corrosive and humid coastal atmosphere</p> <p>The design of equipment and accessories shall be suitable to withstand seismic forces corresponding to an acceleration of 0.1 g.</p>
------------	--	--

<b>4.0 GENERAL TECHNICAL REQUIREMENTS</b>			
S No	Description	Requirements for 9kV 10kA Distribution Class (DH)	Requirements for 9kV 10kA Station Class (SM)
1	Installation	Outdoor	Outdoor
2	Type	Metal Oxide gapless with adhesive coated single wrap type / nylon direct injection moulding	Metal Oxide gapless cage type
3	Housing Material	Injection moulded silicone rubber	Injection moulded silicone rubber
4	Service Voltage	11 kV	11 kV
5	Rated Voltage	12 kV (for 9kV LA)	12 kV (for 9kV LA)
6	Rated Frequency	50 Hz	50 Hz
7	Maximum Continuous Operating Voltage (MCOV), Uc	<b>7.2 kV</b> (rms)	7.2 kV (rms)
8	Arrester Rating Ur	9 kV (rms)	9 kV (rms)
9	Nominal Discharge Current In	<b>10 kA</b>	10 kA
10	<b>Distribution Class</b>	<b>Station Class -DH</b>	<b>Station Class- SM</b>
11	<b>Repetitive Charge transfer withstand (Coulombs ) Qrs</b>	<b>&gt;0.4 C</b>	<b>&gt;1.6 C</b>
12	<b>Thermal Energy withstand rating</b>	<b>Qth (C)</b>	<b>&gt;1.1 C</b>
		<b>Wth (kJ/kV)</b>	<b>-</b>
			<b>&gt; 7 KJ/kV Ur (2 shots)</b>

Rev No.	Description	Prepared By & Date	Checked By & Date	Approved for Issue By & Date
R0	Specification for 11KV / 33KV LA with Porcelain Polymer insulator	Suchismita Nayak	Niranjan Khuntia	Pourush Garg
		05/08/2020	05/08/2020	05/08/2020



<b>TP Central Odisha Distribution Limited</b>	 <b>TPCODL</b> <small>TP CENTRAL ODISHA DISTRIBUTION LIMITED</small>	<b>Specification for 11KV / 33KV LA with Porcelain Polymer insulator</b>
<b>NEG-SPEC-11</b>		<b>Date of Issue: 05/08/2020</b>

13	Insulation Voltage Withstand on Arrester Housing		
13.1	Power Frequency Voltage (Dry/Wet) for one minute.	28 kV (rms)	28 kV (rms)
13.2	Lightning Impulse Voltage kV Peak	75kV (Peak)	75kV (Peak)
14	Rated Short Circuit Current	16KA or better	16kA or better
15	High Current impulse Operating Duty (4/10 $\mu$ s impulse wave) (kAp)	<b>100 (kAp)</b>	<b>100 (kAp)</b>
16	Partial Discharge at 1.05 times M.C.O.V	<10 pC	<10 pC
15	Disconnecter	As per IEC 60099 ed 03	As per IEC 60099 ed 03
<b>15.1</b>	<b>Disconnecter connecting lead</b>	<b>Insulated flexible tinned plated copper braid with lugs</b>	<b>Insulated flexible tinned plated copper braid with lugs</b>
<b>15.2</b>	<b>Size of Insulated Tinned copper braid</b>	<b>25 sqmm</b>	<b>25 sqmm</b>
<b>15.3</b>	<b>Length of Insulated Tinned copper braid</b>	<b>300 mm</b>	<b>300 mm</b>
16	<b>Material of Insulating Bracket</b>	<b>UV resistant Fire retardant DMC</b>	<b>UV resistant Fire retardant DMC</b>
17	<b>Material of End fittings</b>	<b>Machined / pressure die casted Aluminium</b>	<b>Machined / pressure die casted Aluminium</b>
18	Pull Strength (Min.)	1000N	1000N
19	Cantilever Strength (Min.)	12 KGM	12 KGM
20	Total creepage length of the arrester (Min.)	400mm	500mm
21	Stack Height	To be submitted by bidder	To be submitted by bidder
22	Rating of individual ZnO blocks used for assembly	3kV /4.5kV	3kV/ 4.5kV
23	<b>Temporary Over Voltage rating (TOV) kVp</b>	<b>Bidders to submit the offered product values</b>	<b>Bidders to submit the offered product values</b>
23.1	<b>1Sec</b>	<b>Min. 12kV</b>	<b>Min. 12kV</b>
23.2	<b>10 Sec</b>	<b>Min. 12kV</b>	<b>Min. 10kV</b>
23.3	<b>100Sec</b>	<b>Min. 11kV</b>	<b>Min. 9.5kV</b>
24	Maximum Residual Voltage during impulse discharge of 8/20microsec.	Desired Maximum Values	Desired Maximum Values
24.1	<b>5kAp</b>	<b>28 kVpeak</b>	<b>26kVpeak</b>
24.2	<b>10kAp</b>	<b>28 kVpeak</b>	<b>28kVpeak</b>
25	Max Steep lightning current impulse 1/20 $\mu$ s residual voltage	40 kVpeak	33kVpeak
26	<b>Material of Insulating terminal cap</b>	<b>Polyolefin</b>	<b>Polyolefin</b>
27	<b>Material of Nut Bolt washers</b>	<b>Stainless Steel</b>	<b>Stainless Steel</b>
28	Current at MCOV		
28.1	a. Resistive Current	Bidders to submit	Bidders to submit
28.2	b. Capacitive Current	Bidders to submit	Bidders to submit

Rev No.	Description	Prepared By & Date	Checked By & Date	Approved for Issue By & Date
R0	Specification for 11KV / 33KV LA with Porcelain Polymer insulator	Suchismita Nayak	Niranjan Khuntia	Pourush Garg
		05/08/2020	05/08/2020	05/08/2020



TP Central Odisha Distribution Limited		Specification for 11KV / 33KV LA with Porcelain Polymer insulator
NEG-SPEC-11	TP CENTRAL ODISHA DISTRIBUTION LIMITED	Date of Issue: 05/08/2020

29	The bolt grade	All hardware bolt shall be of 8.8 grade	All hardware bolt shall be of 8.8 grade
----	----------------	---	---

5.0	<b>GENERAL CONSTRUCTION</b>	<ol style="list-style-type: none"> <li>Lightning arresters shall be designed with gapless metal oxide elements with silicon housing suitable for operation under the system conditions specified.</li> <li>Arresters shall be completely moulded units with <i>absolutely no air volume inside</i>, suitable for mounting on bracket. <i>Arresters of tubular construction i.e arresters assembled in hollow core insulators with enclosed air volume are not acceptable</i></li> <li>The end fittings shall be non-magnetic and of corrosion proof material.</li> <li>The end fittings used in polymer arrester shall be made from aluminium through machining process/pressure die-casting process. Sand casted and gravity casted end fittings are not acceptable.</li> <li>MOV blocks shall have full metallization to have full face contact and to reduce contact resistance between adjacent discs.</li> <li>Each unit of arrester assembly shall be hermetically sealed, leak tested and protected against ingress of moisture.</li> <li>The seal shall be properly designed and tested for operation under extreme weather conditions.</li> <li>Lightning arrester construction shall be suitable to withstand Seismic Loading, Short Circuit Forces and wind load and the force exerted on the arrester base and to the terminal imposed by the line conductor.</li> </ol>
5.1	<b>ASSEMBLY</b>	<ol style="list-style-type: none"> <li>Lightning arrester shall be supplied along with disconnecter, insulating bracket, Insulating terminal Cap, disconnecter, Insulated tinned copper braid and necessary hard-wares.</li> <li>The Assembly consists of stack of nonlinear Metal Oxide (ZnO) elements with highly non-linear voltage current characteristics, connected in series.</li> <li>All the contact surfaces of metal oxide elements and Aluminium blocks must be smooth to have uniform contact surface.</li> <li>Housing shall be made of Silicon rubber via injection molding to provide thermal dissipation of heat generated in the metal oxide elements during overvoltage and line discharge.</li> <li>Polymeric housing shall be free from air bubble, flaws affecting the mechanical and electrical strength of the arrester.</li> <li>Housing shall be capable to withstand the desired pollution stresses without flashover.</li> <li>The polymer material used for the arrester housing must be tracking and erosion resistant, stabilized against UV radiation.</li> <li>All metal parts shall be of non-rusting and non-corroding metal.</li> <li>The arrester disconnecter shall be suitable for screwing directly to L.A with terminal of M10.</li> <li>Stainless Steel Bolts, Nuts, washers shall be provided.</li> <li>All similar parts, particularly removable ones, shall be interchangeable.</li> <li>The arrester shall have thermal stability to withstand the heat generated from the ZnO element due to continuous operating voltage and surges.</li> <li>The 9kV 10kA station class Lightning Arrester shall have L-shaped terminal</li> </ol>

Rev No.	Description	Prepared By & Date	Checked By & Date	Approved for Issue By & Date
R0	Specification for 11KV / 33KV LA with Porcelain Polymer insulator	Suchismita Nayak	Niranjan Khuntia	Pourush Garg
		05/08/2020	05/08/2020	05/08/2020

<b>TP Central Odisha Distribution Limited</b>		<b>Specification for 11KV / 33KV LA with Porcelain Polymer insulator</b>
<b>NEG-SPEC-11</b>	<b>TP CENTRAL ODISHA DISTRIBUTION LIMITED</b>	<b>Date of Issue: 05/08/2020</b>

		clamp suitable for conductor size of 9mm-16mm diameter.
<b>5.2</b>	<b>DISCONNECTOR</b>	<ol style="list-style-type: none"> <li>Each individual unit of Lightning Arrester with disconnecter shall be hermetically sealed and fully protected against ingress of moisture.</li> <li>The hermetic seal shall be effective for the entire life time of the Lightning Arrester with disconnecter under the specified service conditions.</li> <li>Disconnectors shall give the visible indication of the failed arrester.</li> <li>The Lightning Arrester with disconnecter shall be suitable for bracket type mounting. .</li> <li>The corresponding units of Lightning Arrester with disconnecter of the same rating shall be interchangeable without adversely affecting the performance.</li> <li>All the necessary flanges, bolts, nuts, clamps etc. required for assembly of complete Lightning Arrester with disconnecter and accessories and mounting on purchaser's support structure shall be included in bidder's scope of supply.</li> <li>The mounting details for mounting the Lightning Arrester with disconnecter on purchaser's support shall be given along with the bid.</li> </ol>
<b>5.3</b>	<b>MOUNTING BRACKET</b>	<ol style="list-style-type: none"> <li>The 9kV 10kA Distribution class Lightning Arrester shall be fixed over a mounting bracket made of UV resistance, Fire retardant DMC material.</li> <li>The 9kV 10kA Station class Lightning Arrester shall be fixed over a mounting arrangement made of Hot dip galvanized MS material and additionally one mounting bracket shall be provided</li> </ol>
<b>5.4</b>	<b>MECHANICAL STRENGTH</b>	<ol style="list-style-type: none"> <li>The Lightning Arrester and it base shall withstand rated mechanical terminal load and electromagnetic forces without impairing their operational reliability.</li> <li>The Lightning Arrester shall not come out of their positions by gravity, wind pressure, vibrations or reasonable shocks.</li> </ol>
<b>6.0</b>	<b>NAME PLATE AND MARKING</b>	<ol style="list-style-type: none"> <li>The Lightning Arrester shall be provided with durable and legible name plate embossing, effectively secured against removal.</li> <li>The name plate shall be indelibly and distinctly marked with all essential particulars as per the relevant standards along with the following :</li> <li>The Name plate/product shall have marking of "PO no. with date" &amp; "Property of TPCL"</li> <li>The following information shall be mentioned on the Name Plate: <ol style="list-style-type: none"> <li>Continuous operating Voltage</li> <li>Rated Voltage</li> <li>Rated Frequency</li> <li>Nominal Discharge Current</li> <li>Manufacturer's Name</li> <li>Type and Identification of the complete arrester</li> <li>Year of Manufacture</li> <li>Serial Number</li> </ol> </li> </ol>
<b>7.0</b>	<b>TESTS</b>	<ol style="list-style-type: none"> <li>All routine, acceptance &amp; type tests shall be carried out in accordance with the relevant IS/IEC.</li> <li>All acceptance tests shall be witnessed by the purchaser/his authorized representative.</li> <li>All the components and fittings shall also be type tested as per the relevant standards.</li> </ol>

Rev No.	Description	Prepared By & Date	Checked By & Date	Approved for Issue By & Date
R0	Specification for 11KV / 33KV LA with Porcelain Polymer insulator	Suchismita Nayak	Niranjan Khuntia	Pourush Garg
		05/08/2020	05/08/2020	05/08/2020

<b>TP Central Odisha Distribution Limited</b>		<b>Specification for 11KV / 33KV LA with Porcelain Polymer insulator</b>
<b>NEG-SPEC-11</b>	<b>TP CENTRAL ODISHA DISTRIBUTION LIMITED</b>	<b>Date of Issue: 05/08/2020</b>

		<p>4. Following tests shall be necessarily conducted on the Lightning Arrester in addition to others specified in IS/IEC standards. *In case of any conflict on any technical particular in the specification, the stricter requirement mentioned in the relevant standard shall be valid.</p>																																																									
<b>7.1</b>	<b>TYPE TEST</b>	<p>List of type test Reports to be submitted along with offer as per IEC 60099-4 Ed.3</p> <table border="1"> <thead> <tr> <th>Sr. No.</th> <th>Test to be done</th> <th>Reference BIS / Document</th> </tr> </thead> <tbody> <tr> <td>1</td> <td>Power Frequency reference Voltage test (Both in Dry and Wet condition)</td> <td>As per IEC 60099-4 Ed.3 clause 10.8.2</td> </tr> <tr> <td>2</td> <td>Lightning impulse residual voltage on complete arrester</td> <td>As per IEC 60099-4 Ed.3 clause 10.8.2</td> </tr> <tr> <td>3</td> <td>Residual voltage tests</td> <td>As per IEC 60099-4 Ed.3 clause 10.8.3</td> </tr> <tr> <td>4</td> <td>Test to verify long term stability under continuous operating voltage</td> <td>As per IEC 60099-4 Ed.3 clause 10.8.4</td> </tr> <tr> <td>5</td> <td>Test to verify the repetitive charge transfer rating, Qrs</td> <td>As per IEC 60099-4 Ed.3 clause 10.8.5</td> </tr> <tr> <td>6</td> <td>Heat dissipation behaviour</td> <td>As per IEC 60099-4 Ed.3 clause 10.8.6</td> </tr> <tr> <td>7</td> <td>Operating duty test</td> <td>As per IEC 60099-4 Ed.3 clause 10.8.7</td> </tr> <tr> <td>8</td> <td>Power-frequency voltage-versus-time test characteristic</td> <td>As per IEC 60099-4 Ed.3 clause 10.8.8</td> </tr> <tr> <td>9</td> <td>Tests of arrester disconnector</td> <td>As per IEC 60099-4 Ed.3 clause 10.8.9</td> </tr> <tr> <td>10</td> <td>Operating withstand Test for Disconnector</td> <td>As per IEC 60099-4 Ed.3 clause 8.9.2</td> </tr> <tr> <td>11</td> <td>Disconnector operation test – Current vs time</td> <td>As per IEC 60099-4 Ed.3 clause 8.9.3</td> </tr> <tr> <td>12</td> <td>Mechanical tests on Disconnector</td> <td>As per IEC 60099-4 Ed.3 clause 8.9.4</td> </tr> <tr> <td>13</td> <td>Temperature cycling and seal pumping test on Disconnector</td> <td>As per IEC 60099-4 Ed.3 clause 8.9.5</td> </tr> <tr> <td>14</td> <td>Short-circuit tests a. High current SC b. Low current SC</td> <td>As per IEC 60099-4 Ed.3 clause 10.8.10</td> </tr> <tr> <td>15</td> <td>Bending moment test</td> <td>As per IEC 60099-4 Ed.3 clause 10.8.11</td> </tr> <tr> <td>16</td> <td>Seal leak rate test</td> <td>As per IEC 60099-4 Ed.3 clause 10.8.13</td> </tr> <tr> <td>17</td> <td>Radio interference voltage (RIV) test</td> <td>As per IEC 60099-4 Ed.3 clause 10.8.14</td> </tr> <tr> <td>18</td> <td>Test to verify the dielectric</td> <td>As per IEC 60099-4 Ed.3 clause</td> </tr> </tbody> </table>	Sr. No.	Test to be done	Reference BIS / Document	1	Power Frequency reference Voltage test (Both in Dry and Wet condition)	As per IEC 60099-4 Ed.3 clause 10.8.2	2	Lightning impulse residual voltage on complete arrester	As per IEC 60099-4 Ed.3 clause 10.8.2	3	Residual voltage tests	As per IEC 60099-4 Ed.3 clause 10.8.3	4	Test to verify long term stability under continuous operating voltage	As per IEC 60099-4 Ed.3 clause 10.8.4	5	Test to verify the repetitive charge transfer rating, Qrs	As per IEC 60099-4 Ed.3 clause 10.8.5	6	Heat dissipation behaviour	As per IEC 60099-4 Ed.3 clause 10.8.6	7	Operating duty test	As per IEC 60099-4 Ed.3 clause 10.8.7	8	Power-frequency voltage-versus-time test characteristic	As per IEC 60099-4 Ed.3 clause 10.8.8	9	Tests of arrester disconnector	As per IEC 60099-4 Ed.3 clause 10.8.9	10	Operating withstand Test for Disconnector	As per IEC 60099-4 Ed.3 clause 8.9.2	11	Disconnector operation test – Current vs time	As per IEC 60099-4 Ed.3 clause 8.9.3	12	Mechanical tests on Disconnector	As per IEC 60099-4 Ed.3 clause 8.9.4	13	Temperature cycling and seal pumping test on Disconnector	As per IEC 60099-4 Ed.3 clause 8.9.5	14	Short-circuit tests a. High current SC b. Low current SC	As per IEC 60099-4 Ed.3 clause 10.8.10	15	Bending moment test	As per IEC 60099-4 Ed.3 clause 10.8.11	16	Seal leak rate test	As per IEC 60099-4 Ed.3 clause 10.8.13	17	Radio interference voltage (RIV) test	As per IEC 60099-4 Ed.3 clause 10.8.14	18	Test to verify the dielectric	As per IEC 60099-4 Ed.3 clause
Sr. No.	Test to be done	Reference BIS / Document																																																									
1	Power Frequency reference Voltage test (Both in Dry and Wet condition)	As per IEC 60099-4 Ed.3 clause 10.8.2																																																									
2	Lightning impulse residual voltage on complete arrester	As per IEC 60099-4 Ed.3 clause 10.8.2																																																									
3	Residual voltage tests	As per IEC 60099-4 Ed.3 clause 10.8.3																																																									
4	Test to verify long term stability under continuous operating voltage	As per IEC 60099-4 Ed.3 clause 10.8.4																																																									
5	Test to verify the repetitive charge transfer rating, Qrs	As per IEC 60099-4 Ed.3 clause 10.8.5																																																									
6	Heat dissipation behaviour	As per IEC 60099-4 Ed.3 clause 10.8.6																																																									
7	Operating duty test	As per IEC 60099-4 Ed.3 clause 10.8.7																																																									
8	Power-frequency voltage-versus-time test characteristic	As per IEC 60099-4 Ed.3 clause 10.8.8																																																									
9	Tests of arrester disconnector	As per IEC 60099-4 Ed.3 clause 10.8.9																																																									
10	Operating withstand Test for Disconnector	As per IEC 60099-4 Ed.3 clause 8.9.2																																																									
11	Disconnector operation test – Current vs time	As per IEC 60099-4 Ed.3 clause 8.9.3																																																									
12	Mechanical tests on Disconnector	As per IEC 60099-4 Ed.3 clause 8.9.4																																																									
13	Temperature cycling and seal pumping test on Disconnector	As per IEC 60099-4 Ed.3 clause 8.9.5																																																									
14	Short-circuit tests a. High current SC b. Low current SC	As per IEC 60099-4 Ed.3 clause 10.8.10																																																									
15	Bending moment test	As per IEC 60099-4 Ed.3 clause 10.8.11																																																									
16	Seal leak rate test	As per IEC 60099-4 Ed.3 clause 10.8.13																																																									
17	Radio interference voltage (RIV) test	As per IEC 60099-4 Ed.3 clause 10.8.14																																																									
18	Test to verify the dielectric	As per IEC 60099-4 Ed.3 clause																																																									

Rev No.	Description	Prepared By & Date	Checked By & Date	Approved for Issue By & Date
R0	Specification for 11KV / 33KV LA with Porcelain Polymer insulator	Suchismita Nayak	Niranjan Khuntia	Pourush Garg
		05/08/2020	05/08/2020	05/08/2020

<b>TP Central Odisha Distribution Limited</b>	 <b>TPCODL</b>	<b>Specification for 11KV / 33KV LA with Porcelain Polymer insulator</b>
<b>NEG-SPEC-11</b>	<small>TP CENTRAL ODISHA DISTRIBUTION LIMITED</small>	<b>Date of Issue: 05/08/2020</b>

		withstand of internal components	10.8.15																								
		19 Test of internal grading components	As per IEC 60099-4 Ed.3 clause 10.8.16																								
		20 Thermal cyclic test	As per IEC 60099-4 Ed.3 clause 8.16.2																								
		21 Weather aging Test for 1000 hours of slat fog test and 1000 hours of UV test	As per IEC 60099-4 Ed.3 clause 10.8.17																								
<b>7.2</b>	<b>ROUTINE TEST</b>	<p>The test shall be as per IEC 60099-4 Ed.3 clause no. 9.1 and or IS3070 latest editions,</p> <ol style="list-style-type: none"> <li>1. Measurement of reference voltage test</li> <li>2. Residual Voltage Test on complete arrester</li> <li>3. Internal partial discharge test. This test shall be performed on each arrester unit. The test sample may be shielded against external partial discharges. Internal partial discharge shall not exceed 10 pC</li> <li>4. Satisfactory absence from partial discharges and contact noise shall be checked on each unit by any sensitive method adopted by the manufacturer.</li> <li>5. For arrester for arrester units with an enclosed gas volume and separate sealing system the sealed housing leakage check shall be made on each unit by any sensitive method adopted by the manufacturer on the arrester and on surge monitor.</li> <li>6. Disconnecter Assembly- Proper assembly of each disconnecter has to be demonstrated by either measurement of resistance / capacitance or partial discharges.</li> </ol>																									
<b>7.3</b>	<b>ACCEPTANCE TEST</b>	<table border="1"> <thead> <tr> <th>Sr. No.</th> <th>Test to be done</th> <th>Reference BIS / Document</th> </tr> </thead> <tbody> <tr> <td>1</td> <td>Measurement of power-frequency voltage on the arrester at the reference current.</td> <td>As per IEC 60099-4 Ed.3 clause no. 9.2.1.a or IS:3070 part3 cl.6.2.8</td> </tr> <tr> <td>2</td> <td>Lightning impulse residual voltage on the arrester at nominal discharge current</td> <td>As per IEC 60099-4 Ed.3 clause no. 9.2.1.b or IS:3070 part3 cl.6.4. and table 8</td> </tr> <tr> <td>3</td> <td>Partial Discharge Test (Both in Dry and Wet condition)</td> <td>As per IEC60099 part4 cl.9.1</td> </tr> <tr> <td>4</td> <td>Visual Inspection</td> <td>No damage and loose fitting</td> </tr> <tr> <td>5</td> <td>On disconnecter used in combination with NGLA, bending moment and tensile load tests shall be performed.</td> <td>As per IEC 60099-4 Ed.3 clause no. 9.2.1.d</td> </tr> <tr> <td>6</td> <td>Verification of components and dimensions.</td> <td>As per Approved GTP/TPCL Specification</td> </tr> <tr> <td>7</td> <td>Verification of type test of ZnO Blocks</td> <td>Document Verification</td> </tr> </tbody> </table>	Sr. No.	Test to be done	Reference BIS / Document	1	Measurement of power-frequency voltage on the arrester at the reference current.	As per IEC 60099-4 Ed.3 clause no. 9.2.1.a or IS:3070 part3 cl.6.2.8	2	Lightning impulse residual voltage on the arrester at nominal discharge current	As per IEC 60099-4 Ed.3 clause no. 9.2.1.b or IS:3070 part3 cl.6.4. and table 8	3	Partial Discharge Test (Both in Dry and Wet condition)	As per IEC60099 part4 cl.9.1	4	Visual Inspection	No damage and loose fitting	5	On disconnecter used in combination with NGLA, bending moment and tensile load tests shall be performed.	As per IEC 60099-4 Ed.3 clause no. 9.2.1.d	6	Verification of components and dimensions.	As per Approved GTP/TPCL Specification	7	Verification of type test of ZnO Blocks	Document Verification	
Sr. No.	Test to be done	Reference BIS / Document																									
1	Measurement of power-frequency voltage on the arrester at the reference current.	As per IEC 60099-4 Ed.3 clause no. 9.2.1.a or IS:3070 part3 cl.6.2.8																									
2	Lightning impulse residual voltage on the arrester at nominal discharge current	As per IEC 60099-4 Ed.3 clause no. 9.2.1.b or IS:3070 part3 cl.6.4. and table 8																									
3	Partial Discharge Test (Both in Dry and Wet condition)	As per IEC60099 part4 cl.9.1																									
4	Visual Inspection	No damage and loose fitting																									
5	On disconnecter used in combination with NGLA, bending moment and tensile load tests shall be performed.	As per IEC 60099-4 Ed.3 clause no. 9.2.1.d																									
6	Verification of components and dimensions.	As per Approved GTP/TPCL Specification																									
7	Verification of type test of ZnO Blocks	Document Verification																									

Rev No.	Description	Prepared By & Date	Checked By & Date	Approved for Issue By & Date
R0	Specification for 11KV / 33KV LA with Porcelain Polymer insulator	Suchismita Nayak	Niranjan Khuntia	Pourush Garg
		05/08/2020	05/08/2020	05/08/2020

<b>TP Central Odisha Distribution Limited</b>		<b>Specification for 11KV / 33KV LA with Porcelain Polymer insulator</b>
<b>NEG-SPEC-11</b>	<b>TP CENTRAL ODISHA DISTRIBUTION LIMITED</b>	<b>Date of Issue: 05/08/2020</b>

		8	Peel off test (removal of housing)	Samples shall confirm to the specified design. Samples shall be free from air void, cavity and other visual defects. shall be Design conformation verification.
		9	Thermal stability test	Shall be done randomly on any lot material as per IEC 60099-4 Ed.3 clause 9.2.2 and clause 8.7 or IS:3070 part3 cl.7.3
<b>7.4</b>	<b>SPECIAL TEST as acceptance test</b>	<b>SPECIAL THERMAL STABILITY TEST</b> as per As per IEC 60099-4 Ed.3 clause 9.2.2 and 8.7 or IS:3070 part3 cl.7.3- TPCL. Reserves right to perform special thermal stability test during acceptance if required. No failure from the randomly selected sample shall qualify for acceptance.		
<b>8.0</b>	<b>TYPE TEST CERTIFICATES</b>	<ol style="list-style-type: none"> <li>The bidder shall furnish the type test certificates as mentioned above as per the corresponding standards.</li> <li>All the tests shall be conducted at CPRI / ERDA as per the relevant standards.</li> <li>Type tests should have been conducted in certified Test laboratories during the period not exceeding 5 years from the date of opening the bid.</li> <li>In the event of any discrepancy in the test reports, i.e. any test report not acceptable same shall be carried out without any cost implication to TPCL.</li> </ol>		
<b>9.0</b>	<b>PRE-DESPATCH INSPECTION</b>	<ol style="list-style-type: none"> <li>Equipment shall be subject to inspection by a duly authorized representative of TPCL.</li> <li>Inspection may be made at any stage of manufacture at the option of the purchaser and the equipment if found unsatisfactory as to workmanship or material, the same is liable to rejection.</li> <li>Bidder shall grant free access to the places of manufacture to TPCL's representatives at all times when the work is in progress.</li> <li>Inspection by TPCL or authorized representatives shall not relieve the supplier of his obligation of furnishing equipment in accordance with the specifications.</li> <li>Material shall be dispatched after specific MDCC (Material Dispatch Clearance Certificate) is issued by TPCL.</li> <li>Following documents shall be sent along with material: <ol style="list-style-type: none"> <li>Test report</li> <li>MDCC issued by TPCL</li> <li>Invoice in duplicate</li> <li>Packing list</li> <li>Drawings &amp; catalogue</li> <li>Guarantee / Warrantee card</li> <li>Delivery Challan</li> <li>Other Documents (as applicable)</li> </ol> </li> </ol>		

Rev No.	Description	Prepared By & Date	Checked By & Date	Approved for Issue By & Date
R0	Specification for 11KV / 33KV LA with Porcelain Polymer insulator	Suchismita Nayak	Niranjan Khuntia	Pourush Garg
		05/08/2020	05/08/2020	05/08/2020



TP Central Odisha Distribution Limited		<b>Specification for 11KV / 33KV LA with Porcelain Polymer insulator</b>
NEG-SPEC-11	TP CENTRAL ODISHA DISTRIBUTION LIMITED	<b>Date of Issue: 05/08/2020</b>

<b>10.0</b>	<b>INSPECTION AFTER RECEIPT AT STORE</b>	The material received at TPCL, Bhubaneswar, Odisha store shall be inspected for acceptance and shall be liable for rejection, if found different from the reports of the pre-dispatch inspection and one copy of the report shall be sent to Engineering department.
<b>11.0</b>	<b>GUARANTEE:</b>	<ol style="list-style-type: none"> <li>Bidder shall stand guarantee towards design, materials, workmanship &amp; quality of process/ manufacturing of items under the contract for due and intended performance of the same, as an integrated product delivered under this contract.</li> <li>In the event any defect is found by the Company up to a period of 18 months from the date of commissioning or 24 months from the date of last supplies made under the contract, whichever is earlier, supplier shall be liable to undertake to replace/rectify such defects at his own costs. within mutually agreed timeframe, and to the entire satisfaction of the Company, failing which the Company will be at liberty to get it replaced/rectified at supplier's risks and costs and recover all such expenses plus the Company's own charges( @ 20% of expenses incurred), from the supplier or from the " Security cum Performance Deposit" as the case may be. Bidder shall further be responsible for 'free replacement' for another period of THREE years from the end of the guarantee period for any 'Latent Defects' if noticed and reported by the Company</li> </ol>
<b>12.0</b>	<b>PACKING</b>	<ol style="list-style-type: none"> <li>Bidder shall ensure that all the equipment covered under this specification shall be prepared for rail/road transport in a manner so as to protect the equipment from damage in transit.</li> <li>The material should be packed in vertical position in individual box in such a way that the shape of rain shed does not get deformed during transportation and storage.</li> </ol> <p style="text-align: center;"><b>Note: Single use plastic not to be used for packing of the material.</b></p>
<b>13.0</b>	<b>TENDER SAMPLE</b>	One sample to be submitted during technical bid submission. This shall be Non-returnable basis as we shall perform destructive tests on sample.
<b>14.0</b>	<b>TRAINING</b>	NA
<b>15.0</b>	<b>QUALITY CONTROL</b>	<p>The bidder shall submit with the offer Quality assurance plan indicating the various stages of inspection, the tests and checks which will be carried out on the material of construction, components during manufacture and bought out items and fully assembled component and equipment after finishing. As part of the plan, a schedule for stage and final inspection within the parameters of the delivery schedule shall be furnished. TPCL's engineer or its nominated representative shall have free access to the manufacturer's/sub-supplier's works to carry out inspections.</p> <p>The following information shall necessarily be submitted with the bid:</p> <ol style="list-style-type: none"> <li>List of important raw materials, names of sub-suppliers for raw materials, standards to which raw material is tested and the copies of test reports of the tests carried out on raw materials in presence of Bidder's representatives.</li> <li>List of manufacturing facilities available, level of automation achieved and the areas where manual process exists.</li> <li>List of areas in manufacturing process where stage inspections are normally carried out for quality control and details of these tests and inspections</li> </ol>

Rev No.	Description	Prepared By & Date	Checked By & Date	Approved for Issue By & Date
R0	Specification for 11KV / 33KV LA with Porcelain Polymer insulator	Suchismita Nayak	Niranjan Khuntia	Pourush Garg
		05/08/2020	05/08/2020	05/08/2020

TP Central Odisha Distribution Limited		Specification for 11KV / 33KV LA with Porcelain Polymer insulator
NEG-SPEC-11	TP CENTRAL ODISHA DISTRIBUTION LIMITED	Date of Issue: 05/08/2020

		<p>4. List of testing equipment for final testing with valid calibration reports. Manufacturer shall possess 0.1 class instruments for measurement of losses.</p> <p>5. QAP withhold points for TPCL</p> <p>6. inspection.</p>
16.0	<b>MINIMUM TESTING FACILITIES</b>	Bidder shall have adequate in house testing facilities for carrying out all routine tests, acceptance tests and pre-dispatch inspection as per relevant International / Indian standards.
17.0	<b>MANUFACTURING ACTIVITIES</b>	<p>The successful bidder will have to submit technical compliance document and drawing as per RC line items for getting approval before mass manufacturing.</p> <p>Manufacturing shall start only after getting CAT-A approved drawings or as per intimation from TPCL.</p>
18.0	<b>SPARES, ACCESSORIES ND TOOLS</b>	Not Applicable
19.0	<b>DRAWINGS AND DOCUMENTS</b>	<p>Following drawings and documents shall be prepared based on TPCL specifications and statutory requirements and shall be submitted with the bid:</p> <ol style="list-style-type: none"> <li>Completely filled in Technical Particulars and compliance to each clause of the specification General Technical Requirements to Additional Details.</li> <li>Description of the equipment and all components including brochures.</li> <li>General Drawing arrangement of lightning arrester.</li> <li>Sectional drawing showing internal blocks etc.</li> <li>Bill of material.</li> <li>Experience Certificate and list.</li> <li>Type test certificates.</li> <li>List of makes of major components.</li> </ol> <p><b>Drawings / documents to be submitted after the award of the contract are as under:</b></p> <p><b><u>List of Drawings/Parameters to be submitted:</u></b></p> <ol style="list-style-type: none"> <li>Technical Parameters as asked in Specification (General Technical Particulars, General Technical Requirements, Additional Details, Fittings, Type test Reports and Routine test certificates of bought out accessories).</li> <li>General Arrangement Drawing of the Lightning arrester (Front view and Top view. Complete list of</li> </ol>

Rev No.	Description	Prepared By & Date	Checked By & Date	Approved for Issue By & Date
R0	Specification for 11KV / 33KV LA with Porcelain Polymer insulator	Suchismita Nayak	Niranjan Khuntia	Pourush Garg
		05/08/2020	05/08/2020	05/08/2020

TP Central Odisha Distribution Limited		Specification for 11KV / 33KV LA with Porcelain Polymer insulator
NEG-SPEC-11	TP CENTRAL ODISHA DISTRIBUTION LIMITED	Date of Issue: 05/08/2020

		<p>fittings to be displayed and quantities to be mentioned with the drawing).</p> <p>3. Sectional drawing showing the blocks arrangement.</p> <p>4. Terminal and connection drawings</p> <p>5. Type Test Certificates.</p> <p>6. Installation/ Mounting Instructions/Drawing.</p> <p><b><u>Additional Documents to be submitted :</u></b></p> <p>a. List of raw materials as well as bought out accessories and the names of sub-suppliers selected from those furnished along with offer.</p> <p>b. Type test certificates of the raw materials and bought out accessories.</p> <p>c. The successful Bidder shall submit the <b>routine test certificates of bought out accessories</b> and central excise passes for raw material at the time of routine testing.</p> <p>All the documents &amp; drawings shall be in English language. After the receipt of the order, the successful bidder will be required to furnish all relevant drawings/parameters/calculation to TPCL for approval.</p> <p><b><u>Instruction Manuals:</u></b> Bidder shall furnish softcopies of nicely bound manuals (In English language) covering erection and maintenance instructions and all relevant information and drawings pertaining to the main equipment as well as auxiliary devices.</p>
20.0	<b>GUARANTEED TECHNICAL PARTICULARS</b>	All clauses and points in the Specification to be complied for along with GTR.
21.0	<b>SCHEDULE OF DEVIATIONS</b>	

Rev No.	Description	Prepared By & Date	Checked By & Date	Approved for Issue By & Date
R0	Specification for 11KV / 33KV LA with Porcelain Polymer insulator	Suchismita Nayak	Niranjan Khuntia	Pourush Garg
		05/08/2020	05/08/2020	05/08/2020



<b>TP Central Odisha Distribution Limited</b>	<b>TPCODL</b> <small>TP CENTRAL ODISHA DISTRIBUTION LIMITED</small>	<b>Specification for 11KV / 33KV LA with Porcelain Polymer insulator</b>
<b>NEG-SPEC-11</b>		<b>Date of Issue: 05/08/2020</b>

**(TO BE ENCLOSED WITH THE BID)**

All deviations from this specification shall be set out by the Bidders, clause by Clause in this schedule. Unless specifically mentioned in this Schedule, the tender shall be deemed to confirm the purchaser's specifications:

S.No.	Clause No.	Details of deviation with justifications

We confirm that there are no deviations apart from those detailed above.

Seal of the Company:

Signature

Designation

Rev No.	Description	Prepared By & Date	Checked By & Date	Approved for Issue By & Date
R0	Specification for 11KV / 33KV LA with Porcelain Polymer insulator	Suchismita Nayak	Niranjan Khuntia	Pourush Garg
		05/08/2020	05/08/2020	05/08/2020

<b>TP Central Odisha Distribution Limited</b>		<b>Specification for 11KV / 33KV LA with Porcelain Polymer insulator</b>
<b>NEG-SPEC-11</b>	<b>TP CENTRAL ODISHA DISTRIBUTION LIMITED</b>	<b>Date of Issue: 05/08/2020</b>

**ANNEXURE-I**

**INSPECTION TEST PLAN FOR PRE-DELIVERY OF LIGHTENING ARRESTER**

<b>Sr. No.</b>	<b>Test to be done</b>	<b>Reference BIS / Document</b>	<b>Acceptance criteria</b>
1	Power Frequency reference Voltage test (Both in Dry and Wet condition)	As per IEC 60099-4 Ed.3 clause no. 9.2.1.a or IS:3070 part3 cl.6.2.8	Should withstand as per Specification requirements.
2	Lightning impulse residual voltage on the arrester at nominal discharge current	As per IEC 60099-4 Ed.3 clause no. 9.2.1.b or IS:3070 part3 cl.6.4. and table 8	Should withstand as per Specification requirements.
3	Partial Discharge Test (Both in Dry and Wet condition)	As per IEC60099 part4 cl.9.1	Should withstand as per Specification requirements.
4	Visual Inspection	No damage and loose fitting	Compliance as per Specification requirements and approved drawings
5	Verification of components and dimensions.	As per Approved GTP/TPCL Specification	Compliance as per Specification requirements and approved drawings
6	Verification of type test of ZnO Blocks	Document Verification	Compliance as per Specification requirements and IS/IEC standards
7	Peel off test (removal of housing)	Samples shall confirm to the specified design. Samples shall be free from air void, cavity and other visual defects. shall be Design conformation verification, free	Should meet the Specification requirements without any defect
8	On dis-connector used in combination with NGLA, bending moment and tensile load tests shall be performed.	As per IEC 60099-4 Ed.3 clause no. 9.2.1.d	Dis-connector should withstand parameters as per approved documents.
9	Thermal stability test	Shall be done randomly on any lot material as per IEC 60099-4 Ed.3 clause 9.2.2 or IS:3070 part3 cl.7.3	Shall withstand the variations.

<b>Rev No.</b>	<b>Description</b>	<b>Prepared By &amp; Date</b>	<b>Checked By &amp; Date</b>	<b>Approved for Issue By &amp; Date</b>
R0	Specification for 11KV / 33KV LA with Porcelain Polymer insulator	Suchismita Nayak	Niranjan Khuntia	Pourush Garg
		05/08/2020	05/08/2020	05/08/2020

<b>TP Central Odisha Distribution Limited</b>	<b>TPCODL</b> <small>TP CENTRAL ODISHA DISTRIBUTION LIMITED</small>	<b>Specification for 11KV AB Switch 200A with Porcelain / Polymer insulator</b>
<b>NEG-SPEC-10</b>		<b>Date of Issue: 05/08/2020</b>

**Technical Specification**  
**For**  
**Specification for 11KV AB Switch 200A with Porcelain /  
Polymer insulator**

**TP Central Odisha Distribution Limited.  
Network Engineering Group  
2<sup>nd</sup> Floor, IDCO Tower  
Janpath, Bhubaneswar- 751022**

Rev No.	Description	Prepared By & Date	Checked By & Date	Approved for Issue By & Date
R0	Specification for 11KV AB Switch 200A, with Porcelain / Polymer insulator	Suchismita Nayak	Niranjan Khuntia	Pourush Garg
		05/08/2020	05/08/2020	05/08/2020

TP Central Odisha Distribution Limited		Specification for 11KV AB Switch 200A with Porcelain / Polymer insulator
NEG-SPEC-10	TP CENTRAL ODISHA DISTRIBUTION LIMITED	Date of Issue: 05/08/2020

## Technical Specifications of 11 KV 200 Amp 3 Pole/ 2 Pole AB Switch

### 01.0 Scope: -

This specification covers manufacturing testing and supply of 11KV 200 Amps 50HZ Air Break switches for outdoor installation in horizontal configuration. The switches are suitable for operation under off load conditions only and are intended for use on Distribution Sub – stations and tapping sectionalizing points of 11 KV lines.

### 02.0 Description of the materials: -

The 11KV A.B. Switch sets shall confirm to the following parameters: -

- Number of poles 3
- Number of Post insulator per pole 2nos12KVpostinsulator.
- Nominal system voltage 11KV
- Highest system voltage 12KV
- Rated frequency 50Hz
- System earthing effectively earthed.
- Rated nominal current 200 amps
- Altitude of installation Not exceeding1000M

The post insulators used in the A.B. Switches shall have the following ratings :-

- Power frequency withstand voltage (dry) 35KV (RMS)
- Power frequency withstand voltage(wet) 35KV (RMS)
- Implies withstand voltage(dry) 75KV
- Power frequency puncture withstand 1.3

### 03.0 Standards: -

The AB Switch Set shall conform to the following standards: -

- IS-9920 (Part-I to V)
- IS-2544/1973 (for porcelain post insulators)
- IS-2633, (for galvanization of ferrous parts.) or its latest amendments if any.

### 04.0 Insulator make: -

12KV post insulators complete with post and cap duly cemented to be used in the AB Switch Set conforming to IS-2544/1973.

Rev No.	Description	Prepared By & Date	Checked By & Date	Approved for Issue By & Date
RO	Specification for 11KV AB Switch 200A, with Porcelain / Polymer insulator	Suchismita Nayak	Niranjan Khuntia	Pourush Garg
		05/08/2020	05/08/2020	05/08/2020

<b>TP Central Odisha Distribution Limited</b>		<b>Specification for 11KV AB Switch 200A with Porcelain / Polymer insulator</b>
<b>NEG-SPEC-10</b>	<b>TP CENTRAL ODISHA DISTRIBUTION LIMITED</b>	<b>Date of Issue: 05/08/2020</b>

The bidder shall furnish the type test certificate of the post insulators from their manufacturer for reference and scrutiny. The bidder shall mention make, type of insulation materials, metal fittings, Creepage distance, protected Creepage distance, tensile Strength, compressing strength, torsion strength and cantilever strength.

**05.0 Climatic condition: -**

The A.B. Switch set shall be suitable for operation under the following climatic conditions.

- a. Maximum ambient air temperature 45 o C
- b. Maximum daily average air temperature 35 o C
- c. Maximum yearly average ambient air temperature 30 o C
- d. Maximum temperature attainably by a body
- e. Exposed to the Sun. 50 o C
- f. Minimum ambient air temperature 0 o C
- g. Maximum relative humidity 100%
- h. Minimum number of rainy days per annum 70
- i. Average number of rainy days per annum 120
- j. Average annual rain fall 150cm.
- k. Number of months of tropical monsoon conditions 4
- l. Maximum wind pressure 260Kg./mm<sup>2</sup>
- m. Degree of exposure to atmospheric pollution normally
- n. Atmosphere. Polluted.

**06.0 Other technical details: -**

**06.01 General: -**

The 11KV A.B. Switch Set shall be the gang operated rotating single air break type having 2 post insulators per phase. The operating mechanism shall be suitable for manual operation from the ground level and shall be so designed that all the three phases shall open or close simultaneously. The Switches shall be robust in construction, easy in operation and shall be protected against over travel or staining that might adversely affect any of its parts. The required base M.S. Channel (hot dip galvanized) phase coupling rod, operation rod with intermediate guide braided with flexible electrolytic copper, tail piece of required current carrying capacity and operation mechanism with 'ON' & 'OFF' positions shall be provided. The operation rod shall be medium gage of 32mm diameter nominal bore G.I. pipe single length 6 meters. The phase coupling rod for gang operation shall be of medium gauge 25mm dia & 2100 mm length nominal bore G.I. pipe. The Rating post insulators shall be provide with suitable bearing mounted on a base channel with 8mm dia thrust collar and 6mm split pin made out of stainless steel. The operating down rod shall be coupled to the spindle (minimum dia – 32mm) for gang operation through another suitable

Rev No.	Description	Prepared By & Date	Checked By & Date	Approved for Issue By & Date
RO	Specification for 11KV AB Switch 200A, with Porcelain / Polymer insulator	Suchismita Nayak	Niranjan Khuntia	Pourush Garg
		05/08/2020	05/08/2020	05/08/2020

<b>TP Central Odisha Distribution Limited</b>		<b>Specification for 11KV AB Switch 200A with Porcelain / Polymer insulator</b>
<b>NEG-SPEC-10</b>	<b>TP CENTRAL ODISHA DISTRIBUTION LIMITED</b>	<b>Date of Issue: 05/08/2020</b>

bearing by two numbers 10mm dia stainless steel bolts with double nuts. All the bearings shall be provided with grease nipple. All metal (ferrous) parts shall be galvanized and polished. The pipe shall be galvanized in accordance with IS-4736/1968. The post insulators should be fixed with the base channel using Galvanized Nuts and Bolts.

**06.02. Mounting:-**

The A.B. Switches shall be suitable for horizontal mounting in double pole sub-station structures. MS Galvanized base Channel & base support channel should be of min. size 75x40x6 mm.

**06.03. Switching Blades: -**

It shall be made out of electricity copper with silver plated. The approximate size shall be 220mm X 35 X 6mm. The Switch shall have such a spring mechanism so as to ensure that the speed of the opening of contact is independent of speed of manual operation.

**06.04 Fixed Contacts: -**

The Fixed Jaw type female contacts of size (70x35x6) mm shall be made of electrolytic copper (minimum 95% copper composition) duly silver coated controlled by phosphorous bronze high pressure spring housed in robust G.I. Cover. It is essential that provision shall be made in fixed female contacts to take the shock arising from the closing of moving contact blade without the same being transmitted to the post insulator. The arrangement made in this regard shall be specifically shown in the drawing.

**06.05 Arcing Horn: -**

As the switches are generally meant for isolating transmission line and distribution transformers, suitable arcing horns shall be provided for breaking the charging current horn shall be made of 8 mm dia G.I. Rod with spring assisted operation.

**06.06 Terminal Connectors: -**

Terminal connectors shall be robust in design. The size of fixed connector shall be (65 X 35 X 6 mm) and size of movable connector shall be of (65 X 35) X (65 X 35) X 6mm of copper casting with uniform machine finishing duly silver plated made out of minimum 95% copper composition with 2 nos. 12mm dia holes provided with suitable brass bolts and double nuts, flat washers & 2nos. bimetallic solder less sockets suitable up to 55 mm<sup>2</sup> conductor.

**06.07 Spacing: -**

The minimum clearance between phases to the switch shall be 760mm. The operation down rod shall be at a transverse distance of 300mm from the outer limb of the switch. The centre spacing between two post insulators of the same phase shall be 380 mm. In the open position of the A.B. switches the moving blade shall rotate through 90°. This shall be exhibited in the drawing.

Rev No.	Description	Prepared By & Date	Checked By & Date	Approved for Issue By & Date
RO	Specification for 11KV AB Switch 200A, with Porcelain / Polymer insulator	Suchismita Nayak	Niranjan Khuntia	Pourush Garg
		05/08/2020	05/08/2020	05/08/2020



<b>TP Central Odisha Distribution Limited</b>		<b>Specification for 11KV AB Switch 200A with Porcelain / Polymer insulator</b>
<b>NEG-SPEC-10</b>	<b>TP CENTRAL ODISHA DISTRIBUTION LIMITED</b>	<b>Date of Issue: 05/08/2020</b>

**06.08 Sample, Drawing & Literatures: -**

A copy of drawings of 11KV 200 Amps. A.B. Switch shall be furnished along with the tender.

**06.09** The details of construction and materials of different parts of the A.B. Switch shall clearly be indicate in the tender and illustrative pamphlet / literature for the same shall be submitted along with the tender.

**07.0 TEST & TEST CERTIFICATE: -**

**07.01 Type Test: -**

Certificate for the following type tests conducted on a prototype set of A.B. Switch in a NABL approved test house/CPRI shall have to be submitted along with offer.

Dielectric Test (impulse and one minute were power frequency withstand voltage test.)

- Temperature rise test (for contracts and terminals)
- Shorts Time current and peak withstand current test.
- Mainly active load breaking capacity test.
- Transformer off-load breaking capacity test.
- Line charging breaking capacity test.
- Cable charging breaking test.
- Operation and mechanical endurance test.
- Mechanical strength test for post insulator, as per IS-2444/1937 shall be furnished.
- Test for galvanization of metal (ferrous) parts.

**07.02 Routine /Acceptance Test: -**

The inspection may be carried out by the Purchaser at any stage of manufacture. The successful bidder shall grant free access to the Purchaser's representative at a reasonable time when the work is in progress. The following routine tests shall have to be conducted on each set and results are to be furnished for consideration of deputing inspecting officer for inspection and conduction testing of the materials at the works of the manufacturer. the supplier shall give fifteen days advance intimation to the Purchaser to enable him to depute his representative for witnessing the tests.

1. Power frequency voltage dry test.
2. Measurement of resistance of main circuit.
3. Tests to prove satisfactory operation.
4. Dimension Check
5. Galvanization test.
6. Operational test.

Rev No.	Description	Prepared By & Date	Checked By & Date	Approved for Issue By & Date
RO	Specification for 11KV AB Switch 200A, with Porcelain / Polymer insulator	Suchismita Nayak	Niranjan Khuntia	Pourush Garg
		05/08/2020	05/08/2020	05/08/2020

TP Central Odisha Distribution Limited		Specification for 11KV AB Switch 200A with Porcelain / Polymer insulator
NEG-SPEC-10	TP CENTRAL ODISHA DISTRIBUTION LIMITED	Date of Issue: 05/08/2020

**08.00 Guaranteed Technical Particulars: -**

The bidder shall furnish the guaranteed technical particular duly filled in the format along with the tender.

**09.0 Completeness of Equipment: -**

All fittings, accessories of apparatus which may not have been specifically mentioned in this specification but which are usual or necessary in equipment of similar plat shall be deemed to be included in the specification and shall be supplied by the Tender without extra charge. All plant and equipment shall be completed in all details whether such details are mentioned in the specification or not.



Rev No.	Description	Prepared By & Date	Checked By & Date	Approved for Issue By & Date
R0	Specification for 11KV AB Switch 200A, with Porcelain / Polymer insulator	Suchismita Nayak	Niranjan Khuntia	Pourush Garg
		05/08/2020	05/08/2020	05/08/2020



<b>TP Central Odisha Distribution Limited</b>	 <b>TPCODL</b> <small>TP CENTRAL ODISHA DISTRIBUTION LIMITED</small>	<b>Specification for 11KV AB Switch 200A with Porcelain / Polymer insulator</b>
<b>NEG-SPEC-10</b>		<b>Date of Issue: 05/08/2020</b>

### 11 KV 200 Amp 2 / 3 Pole AB Switch

#### Guaranteed Technical Particulars

Sl. No	Particulars	Requirement	Bidders offer	
			2 pole	3 pole
1	Maker's name & Address	To be specified by the bidder		
2	Type of Switch	Rotating Type		
3	Suitable for mounting	Horizontal only		
4	No. of Breakers per phase	Single Break		
5	No. of Post Insulators per phase	2nos. of 12KV Post Insulators as per IS:2544/73 per phase		
6	Post Insulators			
(a)	Maker's Name & Country of Manufacture of Post Insulator	To be specified by the bidder as per CPRI Test Report		
(b)	Type of cementing	Original Cementing. The insulator to be cemented with MCI (Hot dip galvanised /Al Alloy cap and MCI/Forged steel hot deep galvanized pedestral) as per IS: 2544/1973		
(c)	Power frequency withstand voltage (Dry)	35 KV RMS		
(d)	One minute Power frequency withstand voltage (wet)	35 KV RMS		
(e)	Visible discharge voltage	9KV RMS		

Rev No.	Description	Prepared By & Date	Checked By & Date	Approved for Issue By & Date
R0	Specification for 11KV AB Switch 200A, with Porcelain / Polymer insulator	Suchismita Nayak	Niranjan Khuntia	Pourush Garg
		05/08/2020	05/08/2020	05/08/2020

<b>TP Central Odisha Distribution Limited</b>	 <b>TPCODL</b> <small>TP CENTRAL ODISHA DISTRIBUTION LIMITED</small>	<b>Specification for 11KV AB Switch 200A with Porcelain / Polymer insulator</b>
<b>NEG-SPEC-10</b>		<b>Date of Issue: 05/08/2020</b>

(f)	Dry flash over voltage	85 KV		
(g)	Power frequency puncture withstand voltage	1.3 times of actual dry flash over voltage		
(h)	Creepage distance	320 mm minimum (ISS-2544/1973 & relevant IEC)		
(7)	Impulse withstand voltage for positive & negative polarity (1.2/50 micro second wave)			
(a)	Across the isolating distance	85KV Peak		
(b)	To earth & between poles	75KV Peak		
8	Rated one minute Power frequency withstand voltage			
(a)	Across the Isolating distance	32KV(RMS)		
(b)	To earth & between poles	28KV(RMS)		
9(a)	Rated voltage nominal/ maximum	11/12KV		
(b)	Rated normal current and rated frequency	200 Amps. 50hz		
10	Rated short-circuit making capacity	25KA (Peak)		
11	Rated Short-time current	10KA		

Rev No.	Description	Prepared By & Date	Checked By & Date	Approved for Issue By & Date
R0	Specification for 11KV AB Switch 200A, with Porcelain / Polymer insulator	Suchismita Nayak	Niranjan Khuntia	Pourush Garg
		05/08/2020	05/08/2020	05/08/2020

<b>TP Central Odisha Distribution Limited</b>	 <b>TPCODL</b> <small>TP CENTRAL ODISHA DISTRIBUTION LIMITED</small>	<b>Specification for 11KV AB Switch 200A with Porcelain / Polymer insulator</b>
<b>NEG-SPEC-10</b>		<b>Date of Issue: 05/08/2020</b>

12	Rated peak withstand current	40KA		
13	Rated mainly active load breaking capacity	200 Amp.(RMS)		
14	Rated Transformer off load breaking capacity	6.3 Amp.(RMS)		
15	Rated line charging breaking capacity	2.5 Amp(RMS)		
16	Minimum clearance between adjacent phase			
(a)	Switch closed (center to center)	760mm		
(b)	Switch opened (Center of post insulator to the edge of the blade)	380mm		
17	Temperature rise The Temperature rise should not exceed the maximum limit to 65 o C at an ambient temperature not exceeding 40 o C	65 0 C		
	Copper contacts silver faced terminal of switch intended to be conducted to external conductor by bolts or screws at an ambient temperature should not exceed.	50oC		
18	Vertical clearance from top of insulator cap to mounting channel.	254 mm		

Rev No.	Description	Prepared By & Date	Checked By & Date	Approved for Issue By & Date
R0	Specification for 11KV AB Switch 200A, with Porcelain / Polymer insulator	Suchismita Nayak	Niranjan Khuntia	Pourush Garg
		05/08/2020	05/08/2020	05/08/2020

<b>TP Central Odisha Distribution Limited</b>		<b>Specification for 11KV AB Switch 200A with Porcelain / Polymer insulator</b>
<b>NEG-SPEC-10</b>	<b>TP CENTRAL ODISHA DISTRIBUTION LIMITED</b>	<b>Date of Issue: 05/08/2020</b>

19	Type of contact	a) Self aligned high pressure jaw type fixed contacts of electrolytic copper of size 70 mm x 35mm x 6 mm duly silver plated .Each contact should be riveted with three nos. copper rivets with a bunch ( minimum 3 mm thick) of copper strips /foil each may vary from 0.15 mm to 0.25 mm to and total thickness of copper foil per jaw should be 6 mm . Jaw assemblies are to be bolted through brass bolts and nuts with spring washer. b) Solid rectangular blade type moving contact of electrolytic copper of size 35 mm X 6 mm and length 220 mm duly silver plated ensuring a minimum deposit of silver 10 micron on copper contacts or as may be prescribed under relevant ISS / IEC . c) Pressure springs are to be used in each jaw contacts should be phosphorous bronze having 8nos. of turns X28mm heights X14.4mm diameter with 14 SWG wire .		
17	Connectors:-	Terminal connectors for both movable and fixed should be of copper flat of same size similar to that of moving contact blades (minimum 95% copper composition). The fixed connector shall of size 65 mm x 35 mm x 6 mm and the size of movable connector shall be size (65 X 35) X (65 X 35) X 6mm with machine finishing duly silver plated with 2 nos. 12mm dia		

Rev No.	Description	Prepared By & Date	Checked By & Date	Approved for Issue By & Date
RO	Specification for 11KV AB Switch 200A, with Porcelain / Polymer insulator	Suchismita Nayak	Niranjan Khuntia	Pourush Garg
		05/08/2020	05/08/2020	05/08/2020

<b>TP Central Odisha Distribution Limited</b>		<b>Specification for 11KV AB Switch 200A with Porcelain / Polymer insulator</b>
<b>NEG-SPEC-10</b>	<b>TP CENTRAL ODISHA DISTRIBUTION LIMITED</b>	<b>Date of Issue: 05/08/2020</b>

		holes provided with suitable brass bolts and double nuts, flat washers & 2nos. bimetallic solder less sockets suitable upto 55 mm <sup>2</sup> conductor.		
18	Moving contact supporting angle	Moving contact is to be supported by G.I angle of size 45x45x5 mm on each phase and the moving contact are to be bolted through 2 nos. stainless steel bolts and nuts with suitable stainless steel flat and spring washers.		
19	Galvanization	a) Iron parts shall be hot dip galvanized as per IS2633/1972.(Latest Amendment) , IS :2629/1985 (1 st. Revision),		
		b) The pipe shall be galvanized as per IS-4736/1968.(Latest Amendment)		
20	Phase Coupling Rod	25mm nominal bore G.I. Pipe (Medium gauge)		
(a)	Operating Rod	ISI mark 32mm nominal bore G.I. Pipe (Medium gauge) 6 mtr. long Normal Outside Dia. in mm Wall thickness Max. Min. 25 mm 34.2 33.3 3.25 32 mm 49.9 42 3.25		
(b)	Arcing Horn	8 mm dia G.I. rod with spring assisted operation.		
(c)	Force of fixed contact spring	50lbs to 75 lbs		
(d)	Bearings	4 nos. self lubricated bearing to be		
(e)				
(f)				

Rev No.	Description	Prepared By & Date	Checked By & Date	Approved for Issue By & Date
RO	Specification for 11KV AB Switch 200A, with Porcelain / Polymer insulator	Suchismita Nayak	Niranjan Khuntia	Pourush Garg
		05/08/2020	05/08/2020	05/08/2020

<b>TP Central Odisha Distribution Limited</b>	<b>TPCODL</b> <small>TP CENTRAL ODISHA DISTRIBUTION LIMITED</small>	<b>Specification for 11KV AB Switch 200A with Porcelain / Polymer insulator</b>
<b>NEG-SPEC-10</b>		<b>Date of Issue: 05/08/2020</b>

		provided with grease nipple including 4th bearing being a axial thrust bearing.		
(g)	Locking Arrangement	Pad Lock and key arrangement at both "ON & OFF" position..		
(h)	Earth terminal	Provided at base channel at opposite ends.		
(i)	Copper braided flexible tapes	320mm long 2no. tin coated copper braided flexible tape both end seated with copper sheets duly punched for fixing having minimum weight of 450 grams per meter without sockets.		
(j)	Quick break device	Lever mechanism		
(k)	'T' connector	The 'T' connector provided on the channel having 'Moving Contact' shall be of G.I Nut & Bolt at the bottom end to facilitate replacement of this unit only during requirement and avoid entire change of the arm.		
l)	I-Bolt	The 'I-Bolt" shall be longer with 75 mm thread.		
21	Supporting Channel	75mmx40mmx 6mm M.S.Channel. (Hot dip galvanized)		
22	Weight of each pole	20 Kg (Approximately) ( to be specified by bidder)		
23	Detailed drawing submitted ?	To be provided by bidders		
N.B	i) Ferrous parts shall be duly galvanized as per IS :2629/1985 (1st. Revision),			

Rev No.	Description	Prepared By & Date	Checked By & Date	Approved for Issue By & Date
RO	Specification for 11KV AB Switch 200A, with Porcelain / Polymer insulator	Suchismita Nayak	Niranjan Khuntia	Pourush Garg
		05/08/2020	05/08/2020	05/08/2020

<b>TP Central Odisha Distribution Limited</b>	<b>TPCODL</b> <small>TP CENTRAL ODISHA DISTRIBUTION LIMITED</small>	<b>Specification for 11KV AB Switch 200A with Porcelain / Polymer insulator</b>
<b>NEG-SPEC-10</b>		<b>Date of Issue: 05/08/2020</b>

	(Amendment-2) and non-ferrous parts shall be silver plated.			
	ii) The G.I pipes and rods shall be galvanized as per IS:4736/1968 (1st. Revision), (Amendment-1) for hot-dipped zinc coating on M.S. Tube.			
	iii) Certificate from a Government approved laboratory regarding composition of copper in electrolytic copper casting of materials should be submitted during inspection of materials at the cost of tenderer.			
	iv) Items not covered in the G.T.P, but relevant in Design, manufacturing, quality control & testing of materials shall be governed by the relevant IS with latest Amendment.			

Bidder's Signature with Seal

Rev No.	Description	Prepared By & Date	Checked By & Date	Approved for Issue By & Date
RO	Specification for 11KV AB Switch 200A, with Porcelain / Polymer insulator	Suchismita Nayak	Niranjan Khuntia	Pourush Garg
		05/08/2020	05/08/2020	05/08/2020

TP Central Odisha Distribution Limited	 TP CENTRAL ODISHA DISTRIBUTION LIMITED	Specification for 11KV AB Switch 400A with Porcelain / Polymer insulator
NEG-SPEC-10		Date of Issue: 05/08/2020

**Technical Specification**  
**For**  
**Specification for 11KV AB Switch 400A with Porcelain /**  
**Polymer insulator**

**TP Central Odisha Distribution Limited.**  
**Network Engineering Group**  
**2<sup>nd</sup> Floor, IDCO Tower**  
**Janpath, Bhubaneswar- 751022**

Rev No.	Description	Prepared By & Date	Checked By & Date	Approved for Issue By & Date
RO	Specification for 11KV AB Switch 400A, with Porcelain / Polymer insulator	Suchismita Nayak	Niranjan Khuntia	Pourush Garg
		05/08/2020	05/08/2020	05/08/2020



TP Central Odisha Distribution Limited		Specification for 11KV AB Switch 400A with Porcelain / Polymer insulator
NEG-SPEC-10	TP CENTRAL ODISHA DISTRIBUTION LIMITED	Date of Issue: 05/08/2020

**TECHNICAL SPECIFICATION OF 11KV 3 POLE, 400 AMP , HORIZONTAL TYPE AB SWITCH**

**TECHNICAL SPECIFICATIONS FOR AB SWITCH**

**1. SCOPE:-** This specification covers manufacturing testing and supply of 3 Pole, 400 AMP, 50 Hz, Single break, 11 KV class Air Break switches for outdoor installations to be used at 33/11 KV Sub-stations and for incoming & outgoing Lines suitable for operation under off load conditions.

**1.1 DESCRIPTION OF THE MATERIALS:-**

The A.B. Switch sets shall confirm to the following parameters:-

Sl. No.	Description	Parameters of AB Switch
i)	Number of poles	3
ii)	Number of Post insulator per pole	2 nos. 12 KV class
iii)	Nominal system voltage (KV)	11
iv)	Highest System Voltage (KV)	12
v)	Rated frequency	50HZ
vI)	System earthing	Effectively earthed
vII)	Rated nominal current Amp.	400

The post insulators used in the A.B. Switches shall have the following ratings

Sl.	Description	Parameters P.I. of AB Switches for
		11 KV
i)	Power frequency withstand voltage (dry) KV (RMS)	65
ii)	Power frequency withstand voltage (wet) KV (RMS)	40
iii)	Impulse withstand voltage (dry) KV	
iv)	Power frequency puncture	1.3 times the actual dry flashover voltage of the unit

Rev No.	Description	Prepared By & Date	Checked By & Date	Approved for Issue By & Date
RO	Specification for 11KV AB Switch 400A, with Porcelain / Polymer insulator	Suchismita Nayak 05/08/2020	Niranjan Khuntia 05/08/2020	Pourush Garg 05/08/2020

<b>TP Central Odisha Distribution Limited</b>	<b>TPCODL</b>	<b>Specification for 11KV AB Switch 400A with Porcelain / Polymer insulator</b>
<b>NEG-SPEC-10</b>	<b>TP CENTRAL ODISHA DISTRIBUTION LIMITED</b>	<b>Date of Issue: 05/08/2020</b>

### 1.2 STANDARDS:-

The AB Switch Set shall conform to the following standards:-

- i) IS-9920 (Part-I to V.)
- ii) IS-2544/1973 ( for porcelain post insulators
- iii) IS-2633 (for galvanization of ferrous parts.) or its latest amendments if any.

### 1.3 INSULATORS:-

12 KV class (for 11 KV AB Switches) Post Insulators complete with pedestal cap duly cemented to be used in the AB Switch Set conforming to IS-2544/1973

The bidder shall furnish the type test certificate of the post insulators from their manufacturer for reference.

The bidder shall mention make, type of insulation materials, metal fittings, Creep age distance, protected Creep age distance, tensile strength, compression strength, torsion strength and cantilever strength.

### 1.4 CLIMATIC CONDITIONS:-

The A.B. Switch set shall be suitable for operation under the following climatic Conditions

1. Maximum ambient air temperature. 45 0 C
2. Maximum daily average air temperature 35 0 C
3. Maximum yearly average ambient air temperature 30 0 C
4. Maximum temperature attainable by a body exposed to the sun. 50 0 C
5. Minimum ambient air temperature 0 0 C
6. Maximum relative humidity. 100%
7. Minimum number of rainy days per annum 70
8. Average number of rainy days per annum 120
9. Average annual rain fall. 150 cm.
10. Number of months of tropical monsoon conditions 4
11. Maximum wind pressure. 260 Kg./ mm<sup>2</sup>
12. Degree of exposure to atmospheric pollution. Normally polluted atmosphere.

### 1.5 TECHNICAL DETAILS:-

1.5.1 The 11 KV A.B. Switch Set shall be gang operated single (with double tandem pipe) air break outdoor type horizontal mounting having 2 nos. 12 KV post insulator per phase. The operating mechanism shall be suitable for manual operation from the ground level and shall be so designed that all the three phases shall open or close simultaneously. The Switches shall be robust in construction, easy in operation and shall be protected against over travel or straining that might adversely affect any of its parts. The required base M.S. Channel, phase coupling rod, operating rod with intermediate guide braided with flexible electrolytic copper, tail piece of required current carrying capacity and operating mechanism with 'ON' & 'OFF' positions shall be provided. The operating rod shall be medium gauge of 32mm diameter nominal bore G.I. pipe single piece 6 meters. The phase coupling rod for gang operation shall medium gauge 25mm dia nominal bore G.I. Pipe. Rotating post insulators shall be provided with suitable bearing mounted on a base channel with 6 mm thick thrust collar and 6mm split pin made out of stainless steel. The operating down rod shall be

Rev No.	Description	Prepared By & Date	Checked By & Date	Approved for Issue By & Date
RO	Specification for 11KV AB Switch 400A, with Porcelain / Polymer insulator	Suchismita Nayak	Niranjan Khuntia	Pourush Garg
		05/08/2020	05/08/2020	05/08/2020

<b>TP Central Odisha Distribution Limited</b>		<b>Specification for 11KV AB Switch 400A with Porcelain / Polymer insulator</b>
<b>NEG-SPEC-10</b>	<b>TP CENTRAL ODISHA DISTRIBUTION LIMITED</b>	<b>Date of Issue: 05/08/2020</b>

coupled to the spindle (minimum dia - 32mm) for gang operation through another suitable bearing by two numbers 10mm dia through stainless steel bolts with double nuts. The post insulators should be fixed with the base channel using Galvanized Nuts and Bolts.

All the bearings shall be provided with grease nipple. All ferrous parts shall be galvanized and polished. The pipes shall be galvanized in accordance with IS-4736/1968.

**1.5.2 Mounting: -**

The A.B. Switches shall be suitable for horizontal mounting in all type of sub-station structures.

**1.5.3 Switching Blades: -**

It shall be made out of electrolytic copper with silver plated. The approximate size shall be 250mm x 50 x 8mm for 11 KV. The switch shall have such a spring mechanism so as to ensure that the speed of the opening of contact is independent of speed of manual operation.

**1.5.4 Fixed Contacts:-**

The fixed jaw type female contacts (80x50x8 )mm for 11 KV shall be made of electrolytic copper ( minimum 95 % copper composition) duly electroplated controlled by Stainless Steel high pressure spring housed in robust G.I. Cover. It is essential that provision shall be made in fixed female contacts to take the shock arising from the closing of moving contact blade without the same being transmitted to the post insulator. The arrangement made in this regard shall be specifically shown in the drawing.

**1.5.5 Arcing Horn:-**

As the switches are generally meant for isolating transmission line and distribution transformers, suitable arcing horns shall be provided for breaking the charging current horn shall be made of 10 mm dia G.I. Rod with spring assisted operation.

**1.5.6 Terminal Connectors:-**

Terminal connectors for both movable and fixed should be of copper flats of same size similar to that of moving contact blades (minimum 95% copper composition). The fixed connector shall of size 80 mm x 50 x 8 mm and the size of movable connector shall be size 80 x 50 x 8 mm with machine finishing duly silver plated with 2 nos. of 3/8” stainless steel bolts, nuts, plain washers & spring washers should be provided along with 2 nos solder less bimetallic sockets for each connector suitable sockets for each connector suitable up to 100 mm<sup>2</sup> AAA conductor.

**1.5.7 Spacing:-**

The minimum clearance between phase to the switch shall be 1200 mm. The operating down rod shall be at a transverse distance of 300 mm from the outer limb of the switch. The centre spacing between two post insulators of the same phase shall be 560 mm. In the open position of the A.B. Switches the moving blade shall rotate through an angle of 90 deg . This shall be exhibited in the drawing.

**1.5.8 Drawing & Literatures:-**

Drawings of 11 KV, 400 amp , 3 Pole, single break A.B. Switch shall be furnished along with the tender. The details of construction and materials of different parts of the A.B. Switches shall clearly be indicated in the tender and illustrative pamphlet / literature for the same shall be submitted along with the tender.

**1.6 TESTS & TEST CERTIFICATE**

**1.6.1 Type Test:-**

Rev No.	Description	Prepared By & Date	Checked By & Date	Approved for Issue By & Date
RO	Specification for 11KV AB Switch 400A, with Porcelain / Polymer insulator	Suchismita Nayak	Niranjan Khuntia	Pourush Garg
		05/08/2020	05/08/2020	05/08/2020

<b>TP Central Odisha Distribution Limited</b>		<b>Specification for 11KV AB Switch 400A with Porcelain / Polymer insulator</b>
<b>NEG-SPEC-10</b>	<b>TP CENTRAL ODISHA DISTRIBUTION LIMITED</b>	<b>Date of Issue: 05/08/2020</b>

Certificates for the following type tests conducted within five years proceeding to the date of opening of tender on prototype set of A.B Switch in a Govt. Approved Testing Laboratory preferably at CPRI, Bhopal/ Bangalore shall have to be submitted for reference and scrutiny.

- i. Impulse voltage dry test
- ii. Power frequency voltage dry test
- iii. Power frequency voltage wet test
- iv. Temperature of resistance.
- v. Measurement of resistance.
- vi. Test to prove the capability of carrying the rated peak short circuit current and the rated short time current.
- vii. Mainly active load breaking capacity test. viii. Transformer off-load breaking test.
- ix. Line charging breaking capacity test.
- x. Operation tests.
- xi. Mechanical endurance test.
- xii. Mechanical strength test for the post insulator as per IS-2544/1973.
- xiii. Test for galvanization of metal (ferrous) parts as perm IS-2633/1973.

Besides, mechanical endurance test will have to be conduct on one set in the presence of our authorized person who shall be deputed to carryout acceptance tests before delivery of the materials.

**1.6.2 Routine Tests: -**

The following routine tests shall have to be conducted on each sets and results are to be furnished for consideration of deputing inspecting officer for inspection and conducting testing of the materials.

1. Power frequency voltage dry test
2. Measurement of resistance of main circuit
3. Tests to prove satisfactory operation.
4. Dimension check
5. Galvanization test.

**1.7 GUARANTEED TECHNICAL PARTICULARS:-**

The Bidder shall furnish the guaranteed technical particulars duly filled in the format at Appendix-I along with the tender.

**1.8 COMPLETENESS OF EQUIPMENT:-**

Any fittings, accessories for apparatus which may not have been specifically mentioned in this specification but which are usual or necessary in equipment of similar plant shall be deemed to be included in the specification and shall be supplied by the Tender without extra charge. All plant and equipment shall be completed in all details whether such details are mentioned in the specification or not.

**1.9 INSPECTION:-**

Routine and acceptance tests shall be conducted at the place of manufacturer. The bidder are requested to furnish details of equipment which will be used for testing along with tender. The bidder of those manufacturers who do not have adequate testing facilities for conducting routine and acceptance test are liable for cancellation. The successful bidder has to furnish routine test certificate and guaranteed certificate for approval prior to offer of materials for inspection for each consignment of offer.

Rev No.	Description	Prepared By & Date	Checked By & Date	Approved for Issue By & Date
RO	Specification for 11KV AB Switch 400A, with Porcelain / Polymer insulator	Suchismita Nayak	Niranjan Khuntia	Pourush Garg
		05/08/2020	05/08/2020	05/08/2020

<b>TP Central Odisha Distribution Limited</b>	 <b>TPCODL</b> <small>TP CENTRAL ODISHA DISTRIBUTION LIMITED</small>	<b>Specification for 11KV AB Switch 400A with Porcelain / Polymer insulator</b>
<b>NEG-SPEC-10</b>		<b>Date of Issue: 05/08/2020</b>

**GUARANTEED TECHNICAL PARTICULARS OF 11KV 400AMP 3 POLE AB SWITCH**

S/no.	Perticulars	Requirement	Bidder's Offer
1	Maker's name & Address	To be specified by the bidder	
2	Type of Switch	Rotating Type	
3	Suitable for mounting	Horizontal only	
4	No. of Breakers per phase	Single Break	
5	No. of Post Insulators per phase	2nos. of 12KV Post Insulators per phase as per IS:2544/73	
6	Post Insulators Maker's Name & Country of Manufacture of Post Insulator	Techno Ceramic / Allied Ceramic /JSI/ equivalent Type Test certificates to be provided along with the offer.	
(a)	Type of cementing	Original Cementing. The insulator to be cemented with MCI (Hot dip galvanised /Al Alloy cap and MCI/Forged steel hot deep galvanized pedestral)	
(b)	Power frequency withstand voltage (Dry)	65KV RMS	
(c)	One minute Power frequency withstand voltage (wet)	40KV RMS	
(d)	Visible discharge voltage	9KV RMS	
(e)	Dry flash over voltage	70 KV	
(f)	Power frequency puncture withstand voltage	110KV	
(g)	Creepage distance	320 mm	
(h)	Impulse withstand voltage for positive & negative polarity (1.2/50)		

Rev No.	Description	Prepared By & Date	Checked By & Date	Approved for Issue By & Date
RO	Specification for 11KV AB Switch 400A, with Porcelain / Polymer insulator	Suchismita Nayak 05/08/2020	Niranjan Khuntia 05/08/2020	Pourush Garg 05/08/2020



<b>TP Central Odisha Distribution Limited</b>	 <b>TPCODL</b> TP CENTRAL ODISHA DISTRIBUTION LIMITED	<b>Specification for 11KV AB Switch 400A with Porcelain / Polymer insulator</b>
<b>NEG-SPEC-10</b>		<b>Date of Issue: 05/08/2020</b>

	micro second wave)		
(a)	Across the isolating distance	85KV Peak	
(b)	To earth & between poles	75KV Peak	
8	Rated one minute Power frequency withstand voltage		
(a)	Across the Isolating distance	32KV(RMS)	
(b)	To earth & between poles	28KV(RMS)	
9(a)	Rated voltage nominal/maximum	11/12KV	
(b)	Rated normal current and rated frequency	400 Amps. 50hz	
10	Rated short-circuit making capacity	20KA (Peak)	
11	Rated Short-time current	16KA	
12	Rated peak withstand current	40KA	
13	Rated mainly active load breaking capacity	10KA	
14	Rated transformer off load breaking capacity	16.3A	
15	Rated line charging capacity	2.5A(RMS)	
16	Rated cable charging capacity	10A(RMS)	
17	Minimum clearance between adjacent phase		
(a)	Switch closed (center to center)	Mm	
(b)	Switch opened (Center of post insulator to the edge of the blade)	Mm	
18	Temperature rise The Temperature rise should not exceed the	The Temperature rise of contacts & terminals are within permissible limit of 650C & 50oC respectively.	

Rev No.	Description	Prepared By & Date	Checked By & Date	Approved for Issue By & Date
RO	Specification for 11KV AB Switch 400A, with Porcelain / Polymer insulator	Suchismita Nayak	Niranjan Khuntia	Pourush Garg
		05/08/2020	05/08/2020	05/08/2020

<b>TP Central Odisha Distribution Limited</b>	<b>TPCODL</b>	<b>Specification for 11KV AB Switch 400A with Porcelain / Polymer insulator</b>
<b>NEG-SPEC-10</b>	<b>TP CENTRAL ODISHA DISTRIBUTION LIMITED</b>	<b>Date of Issue: 05/08/2020</b>

	maximum limit to 65oC at an ambient temperature not exceeding 40oC .		
19	Vertical clearance from top of insulator cap to mounting channel.	254 mm	
20	Type of Contact	<p>a) Self aligned, high pressure jaw type fixed contacts of electrolytic copper of size 80 mm x 50 mm x 8 mm duly silver plated. Each contact should be riveted with three nos. Copper rivets with a bunch (minimum 3 mm thick) consisting of copper foils, each may vary from 0.15 mm to 0.25 mm. These total thickness of copper foils per jaw should be 6 mm. Jaw assemblies are to be bolted through stainless steel bolts and nuts with stainless steel flat and spring washer.</p> <p>b) Solid rectangular blade type moving contact of electrolytic copper size 250 mm x50 mm x 8 mm duly silver plated ensuring a minimum deposit of 10 micron of silver on copper contacts or as may be prescribed under relevant ISS / IEC.</p> <p>c) Pressure springs are to be used in each jaw contacts having 8nos. of turns X28mm heights X14.4mm diameter with 14 SWG wire ( minimum six nos. of stainless Steel springs shall be used)</p>	
21.	Terminal connectors:	Terminal connectors for both movable and fixed should be of copper flats of same size similar to that of moving contact blades (minimum 95% copper composition). The fixed connector shall of size 80 mm x 50 x 8 mm and the size	

Rev No.	Description	Prepared By & Date	Checked By & Date	Approved for Issue By & Date
RO	Specification for 11KV AB Switch 400A, with Porcelain / Polymer insulator	Suchismita Nayak 05/08/2020	Niranjan Khuntia 05/08/2020	Pourush Garg 05/08/2020

<b>TP Central Odisha Distribution Limited</b>	<b>TPCODL</b>	<b>Specification for 11KV AB Switch 400A with Porcelain / Polymer insulator</b>
<b>NEG-SPEC-10</b>	<b>TP CENTRAL ODISHA DISTRIBUTION LIMITED</b>	<b>Date of Issue: 05/08/2020</b>

		of movable connector shall be size 80 x 50 x 8 mm with machine finishing duly silver plated with 2 nos. of 3/8" stainless steel bolts, nuts, plain washers & spring washers should be provided along with 2 nos solder less bimetallic sockets for each connector suitable sockets for each connector suitable up to 100 mm <sup>2</sup> AAA conductor.	
22	Terminal support	Movable terminal contact is supported by G.I. angle of size 50 X 50x5mm on each phase and the moving contact are to be bolted through 2 no stainless steel bolts and nuts with suitable stainless steel flat and spring washers.	
23.	Galvanization	a) Iron parts shall be dip galvanized as per IS2633/1972. b) The pipe shall be galvanized as per IS4736/1968.	
24.	Details of Phase		
a)	Coupling Rod	25 mm nominal bore G.I. pipe medium gauge.	
b)	Operating Rod	ISI mark 32 mm nominal bore G.I. pipe medium gauge single length 6 mtrs. The detailed dimension of the G. I. pipe as per IS1239 (Pt. I) as mentioned below :-	
		Nominal base (mm) Outside Diameter (mm) Diameter thickness (mm) Diameter thickness (mm) Max Min 25 34.2 33.3 3.25 32 42.9 42 3.25	
(c)	Arcing Horn	10 mm dia G.I. rod with spring assisted operation	
(d)	Force of fixed contact spring	30 lbs to 50 lbs	

Rev No.	Description	Prepared By & Date	Checked By & Date	Approved for Issue By & Date
RO	Specification for 11KV AB Switch 400A, with Porcelain / Polymer insulator	Suchismita Nayak 05/08/2020	Niranjan Khuntia 05/08/2020	Pourush Garg 05/08/2020



<b>TP Central Odisha Distribution Limited</b>	<b>TPCODL</b>	<b>Specification for 11KV AB Switch 400A with Porcelain / Polymer insulator</b>
<b>NEG-SPEC-10</b>	<b>TP CENTRAL ODISHA DISTRIBUTION LIMITED</b>	<b>Date of Issue: 05/08/2020</b>

(e)	Copper braided flexible taps	320mm long 2no. tin coated copper braided flexible tape both end seated with copper sheets duly punched for fixing	
(f)	Quick break device	Lever mechanism	
(g)	Bearings	4 nos. self lubricated bearing to be provided with grease nipple including 4th bearing being a thrust bearing.	
(h)	Locking arrangement	Pad Lock & Key arrangement at both 'ON' & 'OFF' position.	
(i)	Earth Terminal	To be provided at base channels	
25.	Supporting Channels	75 x 40 x 5mm hot dip galvanized Channel.	
26.	Weight of each pole complete	To be specified by the tender	
27	Detailed Drawing	To be provided by the bidder	

NB: Every AB Switch should bear the marking of manufacturer's name ,Purchaser's name , P.O. No., Sl. No. etc.

Name & Signature of Bidder with seal

Rev No.	Description	Prepared By & Date	Checked By & Date	Approved for Issue By & Date
RO	Specification for 11KV AB Switch 400A, with Porcelain / Polymer insulator	Suchismita Nayak	Niranjan Khuntia	Pourush Garg
		05/08/2020	05/08/2020	05/08/2020

<b>TP Central Odisha Distribution Limited</b>	 <small>TP CENTRAL ODISHA DISTRIBUTION LIMITED</small>	<b>Specification for 33KV AB Switch 400A with Porcelain / Polymer insulator</b>
<b>NEG-SPEC-10</b>		<b>Date of Issue: 05/08/2020</b>

**Technical Specification**  
**For**  
**Specification for 33KV AB Switch 400A with Porcelain /  
Polymer insulator**

**TP Central Odisha Distribution Limited.**  
**Network Engineering Group**  
**2<sup>nd</sup> Floor, IDCO Tower**  
**Janpath, Bhubaneswar- 751022**

Rev No.	Description	Prepared By & Date	Checked By & Date	Approved for Issue By & Date
RO	Specification for 33KV AB Switch 400A, with Porcelain / Polymer insulator	Suchismita Nayak	Niranjan Khuntia	Pourush Garg
		05/08/2020	05/08/2020	05/08/2020

<b>TP Central Odisha Distribution Limited</b>		<b>Specification for 33KV AB Switch 400A with Porcelain / Polymer insulator</b>
<b>NEG-SPEC-10</b>	<b>TP CENTRAL ODISHA DISTRIBUTION LIMITED</b>	<b>Date of Issue: 05/08/2020</b>

**TECHNICAL SPECIFICATION OF 33KV 3 POLE, 400 AMP , HORIZONTAL TYPE AB SWITCH**

**TECHNICAL SPECIFICATIONS FOR AB SWITCH**

**1. SCOPE:-** This specification covers manufacturing testing and supply of 3 Pole, 400 AMP, 50 Hz, Single break, 33 KV class Air Break switches for outdoor installations to be used at 33/11 KV Sub-stations and for incoming & outgoing Lines suitable for operation under off load conditions.

**1.1 DESCRIPTION OF THE MATERIALS:-**

The A.B. Switch sets shall confirm to the following parameters:-

Sl. No.	Description	Parameters of AB Switch
		33KV
i)	Number of poles	3
ii)	Number of Post insulator per pole	4 nos. 22/24 KV class
iii)	Nominal system voltage (KV)	33
iv)	Highest System Voltage (KV)	36
v)	Rated frequency	50HZ
vI)	System earthing	Effectively earthed
vII)	Rated nominal current Amp.	
viii)	Altitude of Installation	Not exceeding 1000M

The post insulators used in the A.B. Switches shall have the following ratings

Sl.	Description	Parameters P.I. of AB Switches for
		33 KV
i)	Power frequency withstand voltage (dry) KV (RMS)	95
ii)	Power frequency withstand voltage (wet) KV (RMS)	75
iii)	Impulse withstand voltage (dry) KV	170 KV( Peak)
iv)	Power frequency puncture	1.3 times the actual dry flashover voltage of the unit

Rev No.	Description	Prepared By & Date	Checked By & Date	Approved for Issue By & Date
RO	Specification for 33KV AB Switch 400A, with Porcelain / Polymer insulator	Suchismita Nayak 05/08/2020	Niranjan Khuntia 05/08/2020	Pourush Garg 05/08/2020

TP Central Odisha Distribution Limited		Specification for 33KV AB Switch 400A with Porcelain / Polymer insulator
NEG-SPEC-10	TP CENTRAL ODISHA DISTRIBUTION LIMITED	Date of Issue: 05/08/2020

### 1.2 STANDARDS:-

The AB Switch Set shall conform to the following standards:-

- i) IS-9920 (Part-I to V.)
- ii) IS-2544/1973 ( for porcelain post insulators
- iii) IS-2633 (for galvanization of ferrous parts.) or its latest amendments if any.

### 1.3 INSULATORS:-

22 KV / 24 KV class (for 33 KV AB Switches) Post Insulators complete with pedestal cap duly cemented to be used in the AB Switch Set conforming to IS-2544/1973

The bidder shall furnish the type test certificate of the post insulators from their manufacturer for reference.

The bidder shall mention make, type of insulation materials, metal fittings, Creep age distance, protected Creep age distance, tensile strength, compression strength, torsion strength and cantilever strength.

### 1.4 CLIMATIC CONDITIONS:-

The A.B. Switch set shall be suitable for operation under the following climatic Conditions

1. Maximum ambient air temperature. 45 0 C
2. Maximum daily average air temperature 35 0 C
3. Maximum yearly average ambient air temperature 30 0 C
4. Maximum temperature attainable by a body exposed to the sun. 50 0 C
5. Minimum ambient air temperature 0 0 C
6. Maximum relative humidity. 100%
7. Minimum number of rainy days per annum 70
8. Average number of rainy days per annum 120
9. Average annual rain fall. 150 cm.
10. Number of months of tropical monsoon conditions 4
11. Maximum wind pressure. 260 Kg./ mm<sup>2</sup>
12. Degree of exposure to atmospheric pollution. Normally polluted atmosphere.

### 1.5 TECHNICAL DETAILS:-

1.5.1 The 33 KV A.B. Switch Set shall be gang operated single (with double tandem pipe) air break outdoor type horizontal mounting having 4 nos. 22/24 KV post insulator per phase. The operating mechanism shall be suitable for manual operation from the ground level and shall be so designed that all the three phases shall open or close simultaneously. The Switches shall be robust in construction, easy in operation and shall be protected against over travel or straining that might adversely affect any of its parts. The required base M.S. Channel, phase coupling rod, operating rod with intermediate guide braided with flexible electrolytic copper, tail piece of required current

Rev No.	Description	Prepared By & Date	Checked By & Date	Approved for Issue By & Date
RO	Specification for 33KV AB Switch 400A, with Porcelain / Polymer insulator	Suchismita Nayak	Niranjan Khuntia	Pourush Garg
		05/08/2020	05/08/2020	05/08/2020

<b>TP Central Odisha Distribution Limited</b>	<b>TPCODL</b>	<b>Specification for 33KV AB Switch 400A with Porcelain / Polymer insulator</b>
<b>NEG-SPEC-10</b>	<b>TP CENTRAL ODISHA DISTRIBUTION LIMITED</b>	<b>Date of Issue: 05/08/2020</b>

carrying capacity and operating mechanism with ‘ON’ & ‘OFF’ positions shall be provided. The operating rod shall be medium gauge of 32mm diameter nominal bore G.I. pipe single piece 6 meters. The phase coupling rod for gang operation shall medium gauge 25mm dia nominal bore G.I. Pipe. Rotating post insulators shall be provided with suitable bearing mounted on a base channel with 6 mm thick thrust collar and 6mm split pin made out of stainless steel. The operating down rod shall be coupled to the spindle (minimum dia - 32mm) for gang operation through another suitable bearing by two numbers 10mm dia through stainless steel bolts with double nuts. The post insulators should be fixed with the base channel using Galvanized Nuts and Bolts. All the bearings shall be provided with grease nipple. All ferrous parts shall be galvanized and polished. The pipes shall be galvanized in accordance with IS-4736/1968.

**1.5.2 Mounting: -**

The A.B. Switches shall be suitable for horizontal mounting in all type of sub-station structures.

**1.5.3 Switching Blades: -**

It shall be made out of electrolytic copper with silver plated. The approximate size shall be 250mm x 50 x 8mm . The switch shall have such a spring mechanism so as to ensure that the speed of the opening of contact is independent of speed of manual operation.

**1.5.4 Fixed Contacts:-**

The fixed jaw type female contacts (80x50x8 )mm for 33KV shall be made of electrolytic copper ( minimum 95 % copper composition) duly electroplated controlled by Stainless Steel high pressure spring housed in robust G.I. Cover. It is essential that provision shall be made in fixed female contacts to take the shock arising from the closing of moving contact blade without the same being transmitted to the post insulator. The arrangement made in this regard shall be specifically shown in the drawing.

**1.5.5 Arcing Horn:-**

As the switches are generally meant for isolating transmission line and distribution transformers, suitable arcing horns shall be provided for breaking the charging current horn shall be made of 10 mm dia G.I. Rod with spring assisted operation.

**1.5.6 Terminal Connectors:-**

Terminal connectors for both movable and fixed should be of copper flats of same size similar to that of moving contact blades (minimum 95% copper composition). The fixed connector shall of size 80 mm x 50 x 8 mm and the size of movable connector shall be size (80 x 50) x (80 X 50) X8 mm of copper casting with uniform machine finishing duly silver plated with suitable brass bolts and double nuts, flat washers & spring washers should be provided along with 2 nos solder less bimetallic sockets for each connector suitable sockets for each connector suitable up to 232 mm<sup>2</sup> ACSR conductor.

**1.5.7 Spacing:-**

The minimum clearance between phase to the switch shall be 1200 mm. The operating down rod shall be at a transverse distance of 300 mm from the outer limb of the switch. The centre spacing between two post insulators of the same phase shall be 560 mm. In the open position of the A.B.

Rev No.	Description	Prepared By & Date	Checked By & Date	Approved for Issue By & Date
RO	Specification for 33KV AB Switch 400A, with Porcelain / Polymer insulator	Suchismita Nayak	Niranjan Khuntia	Pourush Garg
		05/08/2020	05/08/2020	05/08/2020

<b>TP Central Odisha Distribution Limited</b>		<b>Specification for 33KV AB Switch 400A with Porcelain / Polymer insulator</b>
<b>NEG-SPEC-10</b>	<b>TP CENTRAL ODISHA DISTRIBUTION LIMITED</b>	<b>Date of Issue: 05/08/2020</b>

Switches the moving blade shall rotate through an angle of 90 deg . This shall be exhibited in the drawing.

**1.5.8 Drawing & Literatures:-**

Drawings of 33 KV, 400 amp , 3 Pole, single break A.B. Switch shall be furnished along with the tender.

The details of construction and materials of different parts of the A.B. Switches shall clearly be indicated in the tender and illustrative pamphlet / literature for the same shall be submitted along with the tender.

**1.6 TESTS & TEST CERTIFICATE**

**1.6.1 Type Test:-**

Certificates for the following type tests conducted within five years proceeding to the date of opening of tender on prototype set of A.B Switch in a Govt. Approved Testing Laboratory preferably at CPRI, Bhopal/ Bangalore shall have to be submitted for reference and scrutiny.

- i. Impulse voltage dry test
- ii. Power frequency voltage dry test
- iii. Power frequency voltage wet test
- iv. Temperature of resistance.
- v. Measurement of resistance.
- vi. Test to prove the capability of carrying the rated peak short circuit current and the rated short time current.
- vii. Mainly active load breaking capacity test.
- viii. Transformer off-load breaking test.
- ix. Line charging breaking capacity test.
- x. Operation tests.
- xi. Mechanical endurance test.
- xii. Mechanical strength test for the post insulator as per IS-2544/1973.
- xiii. Test for galvanization of metal (ferrous) parts as perm IS-2633/1973.

Besides, mechanical endurance test will have to be conduct on one set in the presence of our authorized person who shall be deputed to carryout acceptance tests before delivery of the materials.

**1.6.2 Routine Tests: -**

The following routine tests shall have to be conducted on each sets and results are to be furnished for consideration of deputing inspecting officer for inspection and conducting testing of the materials.

1. Power frequency voltage dry test
2. Measurement of resistance of main circuit
3. Tests to prove satisfactory operation.
4. Dimension check
5. Galvanization test.

**1.7 GUARANTEED TECHNICAL PARTICULARS:-**

The Bidder shall furnish the guaranteed technical particulars duly filled in the format at Appendix-I along with the tender.

**1.8 COMPLETENESS OF EQUIPMENT:-**

Rev No.	Description	Prepared By & Date	Checked By & Date	Approved for Issue By & Date
RO	Specification for 33KV AB Switch 400A, with Porcelain / Polymer insulator	Suchismita Nayak	Niranjan Khuntia	Pourush Garg
		05/08/2020	05/08/2020	05/08/2020



<b>TP Central Odisha Distribution Limited</b>	<b>TPCODL</b> <small>TP CENTRAL ODISHA DISTRIBUTION LIMITED</small>	<b>Specification for 33KV AB Switch 400A with Porcelain / Polymer insulator</b>
<b>NEG-SPEC-10</b>		<b>Date of Issue: 05/08/2020</b>

Any fittings, accessories for apparatus which may not have been specifically mentioned in this specification but which are usual or necessary in equipment of similar plant shall be deemed to be included in the specification and shall be supplied by the Tender without extra charge. All plant and equipment shall be completed in all details whether such details are mentioned in the specification or not.

**1.9 INSPECTION:-**

Routine and acceptance tests shall be conducted at the place of manufacturer. The bidder are requested to furnish details of equipment which will be used for testing along with tender. The bidder of those manufacturers who do not have adequate testing facilities for conducting routine and acceptance test are liable for cancellation. The successful bidder has to furnish routine test certificate and guaranteed certificate for approval prior to offer of materials for inspection for each consignment of offer.

**GUARANTEED TECHNICAL PARTICULARS OF 11KV 400AMP 3 POLE AB SWITCH**

Slno.	Perticulars	Requirement	Bidder's Offer
1	Maker's name & Address	To be specified by the bidder	
2	Type of Switch	Rotating Type	
3	Suitable for mounting	Horizontal only	
4	No. of Breakers per phase	Single Break	
5	No. of Post Insulators per phase	4 nos. of 22/24 KV Post Insulators per phase as per IS:2544/73	
6	Post Insulators		
(a)	Maker's Name & Country of Manufacture of Post Insulator	Techno Ceramic / Allied Ceramic /JSI/ equivalent Type Test certificates to be provided along with the offer.	
(b)	Type of cementing	Original Cementing. The insulator to be cemented with MCI (Hot dip galvanised /Al Alloy cap and MCI/Forged steel hot deep galvanized pedestral)	
(c)	Power frequency withstand voltage (Dry)	95 KV RMS	
(d)	One minute Power	75 KV RMS	

Rev No.	Description	Prepared By & Date	Checked By & Date	Approved for Issue By & Date
RO	Specification for 33KV AB Switch 400A, with Porcelain / Polymer insulator	Suchismita Nayak 05/08/2020	Niranjan Khuntia 05/08/2020	Pourush Garg 05/08/2020

<b>TP Central Odisha Distribution Limited</b>	 <b>TPCODL</b> <small>TP CENTRAL ODISHA DISTRIBUTION LIMITED</small>	<b>Specification for 33KV AB Switch 400A with Porcelain / Polymer insulator</b>
<b>NEG-SPEC-10</b>		<b>Date of Issue: 05/08/2020</b>

	frequency withstand voltage (wet)		
(e)	Visible discharge voltage	27 KV RMS	
(f)	Dry flash over voltage	To be specified by the Tenderer	
(g)	Power frequency puncture withstand voltage	1.3 times of actual dry flash Over Voltage	
(h)	Creepage distance	450 mm	
(7)	Impulse withstand voltage for positive & negative polarity (1.2/50 micro second wave) switch in Position	170KV Peak	
(a)	Across the isolating distance	195 KV Peak	
(b)	To earth & between poles	170 KV Peak	
8	Rated one minute Power frequency withstand voltage		
(a)	Across the Isolating distance	80 KV(RMS)	
(b)	To earth & between poles	70 KV(RMS)	
9(a)	Rated normal current and rated frequency	400 Amps. 50hz	
(b)	Rated Short-time current	16KA	
10	Rated short-circuit making capacity	25 KA ( RMS )	
11	Rated peak withstand current	40KA (Peak)	
12	Rated cable charging breaking capacity	40KA(RMS)	
13	Rated transformer off load breaking capacity	16 A RMS	
14	Rated line charging capacity	5.3 A(RMS)	
15	Minimum clearance between adjacent phase		

Rev No.	Description	Prepared By & Date	Checked By & Date	Approved for Issue By & Date
RO	Specification for 33KV AB Switch 400A, with Porcelain / Polymer insulator	Suchismita Nayak	Niranjan Khuntia	Pourush Garg
		05/08/2020	05/08/2020	05/08/2020



<b>TP Central Odisha Distribution Limited</b>	 <b>TPCODL</b> <small>TP CENTRAL ODISHA DISTRIBUTION LIMITED</small>	<b>Specification for 33KV AB Switch 400A with Porcelain / Polymer insulator</b>
<b>NEG-SPEC-10</b>		<b>Date of Issue: 05/08/2020</b>

(a)	Switch closed (center to center)	1200 Mm	
(b)	Switch opened (Center of post insulator to the edge of the blade)	640 Mm	
16	Temperature rise The Temperature rise should not exceed the maximum limit as specified below at an ambient temperature not exceeding in 40 deg C		
a)	Copper contacts in air	65 deg C	
b)	Terminal of Switch intended to be connected to external conductor by bolts	50 deg C	
17	Vertical clearance from top of insulator cap to mounting channel.	508 mm (minimum)	
18	Type of Contact	a) Self aligned, high pressure jaw type fixed contacts of electrolytic copper of size 95 mm x 50 mm x 8 mm duly silver plated. Each contact should be riveted with three nos. Copper rivets with a bunch (minimum 3 mm thick) consisting of copper foils, each may vary from 0.15 mm to 0.25 mm. These total thickness of copper foils per jaw should be 6 mm. Jaw assemblies are to be bolted through stainless steel bolts and nuts with stainless steel flat and spring washer.	

Rev No.	Description	Prepared By & Date	Checked By & Date	Approved for Issue By & Date
RO	Specification for 33KV AB Switch 400A, with Porcelain / Polymer insulator	Suchismita Nayak	Niranjan Khuntia	Pourush Garg
		05/08/2020	05/08/2020	05/08/2020

<b>TP Central Odisha Distribution Limited</b>	<b>TPCODL</b>	<b>Specification for 33KV AB Switch 400A with Porcelain / Polymer insulator</b>
<b>NEG-SPEC-10</b>	<b>TP CENTRAL ODISHA DISTRIBUTION LIMITED</b>	<b>Date of Issue: 05/08/2020</b>

		<p>b) Solid rectangular blade type moving contact of electrolytic copper size 250 mm x50 mm x 8 mm duly silver plated ensuring a minimum deposit of 10 micron of silver on copper contacts or as may be prescribed under relevant ISS / IEC.</p> <p>c) Pressure springs are to be used in each jaw contacts having 8nos. of turns X28mm heights X14.4mm diameter with 14 SWG wire ( minimum six nos. of stainless Steel springs shall be used)</p>	
19	Connectors	Terminal connectors for both movable and fixed should be of copper flats of same size similar to that of moving contact blades (minimum 95% copper composition). The fixed connector shall of size 80 mm x 50 x 8 mm and the size of movable connector shall be size 80 x 50 x 8 mm with machine finishing duly silver plated with 2 nos. of 3/8" stainless steel bolts, nuts, plain washers & spring washers should be provided along with 2 nos solder less bimetallic sockets for each connector suitable sockets for each connector suitable up to 232 mm <sup>2</sup> AAA conductor	
20	Moving Contacts supports:-	Movable contact is to be supported by galvanized angle of 50 x 50 x 5 mm in each phase and the moving contact are to be bolted through 2 no stainless steel bolts and nuts with suitable stainless steel flat and spring washers.	
21.	Galvanization	<p>a) Iron parts shall be dip galvanized as per IS2633/1972.</p> <p>b) The pipe shall be galvanized as per IS4736/1968.</p>	
22.	Details of Phase		
a)	Coupling Rod	25 mm nominal bore G.I. pipe	

Rev No.	Description	Prepared By & Date	Checked By & Date	Approved for Issue By & Date
RO	Specification for 33KV AB Switch 400A, with Porcelain / Polymer insulator	Suchismita Nayak	Niranjan Khuntia	Pourush Garg
		05/08/2020	05/08/2020	05/08/2020

<b>TP Central Odisha Distribution Limited</b>	<b>TPCODL</b>	<b>Specification for 33KV AB Switch 400A with Porcelain / Polymer insulator</b>
<b>NEG-SPEC-10</b>	<b>TP CENTRAL ODISHA DISTRIBUTION LIMITED</b>	<b>Date of Issue: 05/08/2020</b>

		medium gauge.	
b)	Operating Rod	ISI mark 32 mm nominal bore G.I. pipe medium gauge single length 6 mtrs. The detailed dimension of the G. I. pipe as per IS1239 (Pt. I) as mentioned below :- Nominal base (mm) Outside Diameter (mm) Diameter thickness (mm) Diameter thickness (mm) Max Min 25 34.2 33.3 3.25 32 42.9 42 3.25	
(c)	Arcing Horn	10 mm dia G.I. rod with spring assisted operation	
(d)	Force of fixed contact spring	To be specified by Tenderer	
(e)	Copper braided flexible taps	450 mm long 2 nos. of flexible electrolytic copper tape or braided chord (with tin coated) having minimum weight 450 gms per meter and both ends shall be crimped with copper sockets through brass bolts and nuts with brass flat washers. Two nos. of suitable copper sockets shall be used at both ends. The minimum no. of flexible wires should be 1536 of 36 SWG for each flexible chord	
(f)	Quick break device	Lever mechanism	
(g)	Bearings	4 nos. self lubricated bearing to be provided with grease nipple including 4th bearing being a thrust bearing.	
h)	Locking arrangement	Pad Lock & Key arrangement at both 'ON' & 'OFF' position.	
i)	Earth Terminal	To be provided at base channels	
25.	Supporting Channels	100 x 50 x 5mm MS CHANNEL hot	

Rev No.	Description	Prepared By & Date	Checked By & Date	Approved for Issue By & Date
RO	Specification for 33KV AB Switch 400A, with Porcelain / Polymer insulator	Suchismita Nayak	Niranjan Khuntia	Pourush Garg
		05/08/2020	05/08/2020	05/08/2020

<b>TP Central Odisha Distribution Limited</b>	<b>TPCODL</b> <small>TP CENTRAL ODISHA DISTRIBUTION LIMITED</small>	<b>Specification for 33KV AB Switch 400A with Porcelain / Polymer insulator</b>
<b>NEG-SPEC-10</b>		<b>Date of Issue: 05/08/2020</b>

		dip galvanized Chanel.	
26.	Weight of each pole complete	To be specified by the tender	
27	Detailed Drawing	To be provided by the bidder	

NB: Every AB Switch should bear the marking of manufacturer's name ,Purchaser's name , P.O. No., Sl. No. etc.

Name & Signature of Bidder with seal

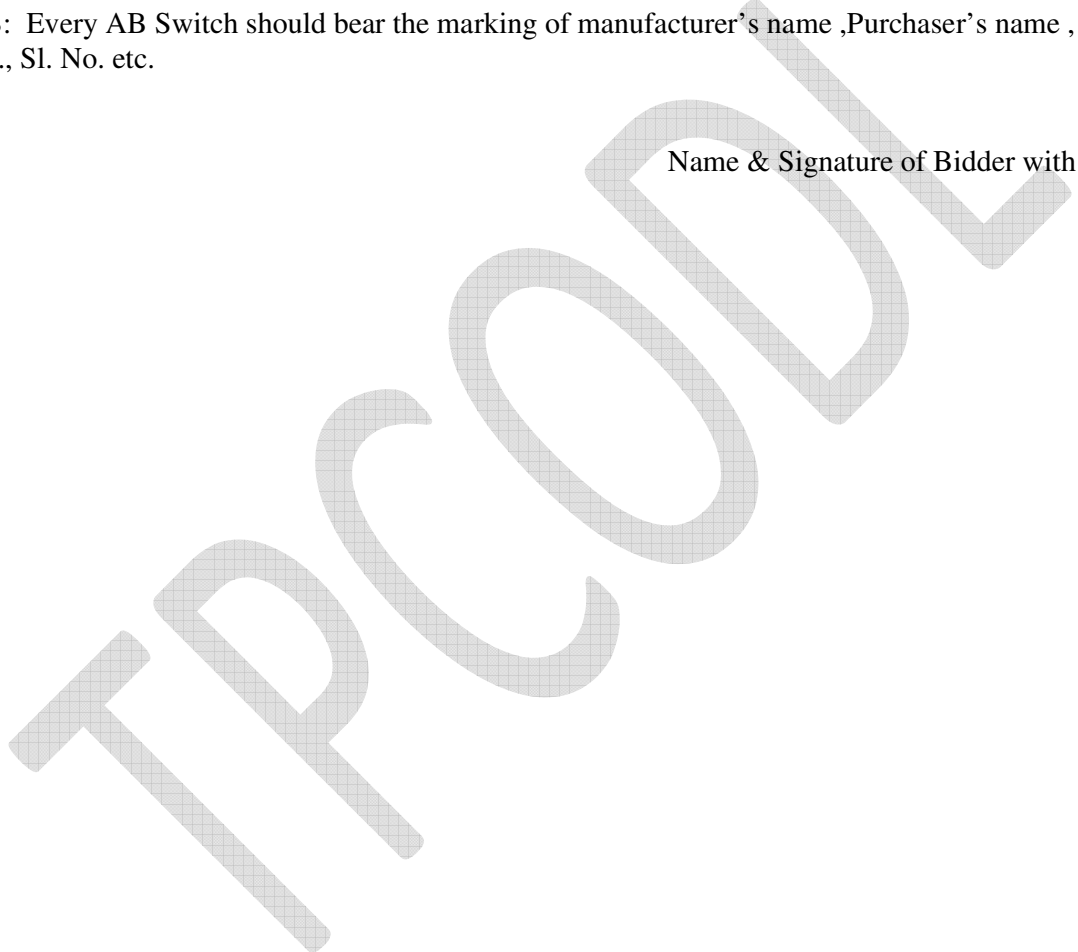

Rev No.	Description	Prepared By & Date	Checked By & Date	Approved for Issue By & Date
RO	Specification for 33KV AB Switch 400A, with Porcelain / Polymer insulator	Suchismita Nayak	Niranjan Khuntia	Pourush Garg
		05/08/2020	05/08/2020	05/08/2020

<b>TP Central Odisha Distribution Limited</b>	<b>TPCODL</b> <small>TP CENTRAL ODISHA DISTRIBUTION LIMITED</small>	<b>Specification for Eye hook for LT PSC Pole</b>
<b>NEG-SPEC-15</b>		<b>Date of Issue: 05/08/2020</b>

**Technical Specification**  
**For**  
**Specification for Eye hook for LT PSC Pole**

**TP Central Odisha Distribution Limited.**  
**Network Engineering Group**  
**2<sup>nd</sup> Floor, IDCO Tower**  
**Janpath, Bhubaneswar- 751022**

Rev No.	Description	Prepared By & Date	Checked By & Date	Approved for Issue By & Date
R0	Specification for Eye hook for LT PSC Pole	Suchismita Nayak	Niranjan Khuntia	Pourush Garg
		05/08/2020	05/08/2020	05/08/2020

<b>TP Central Odisha Distribution Limited</b>		<b>Specification for Eye hook for LT PSC Pole</b>
<b>NEG-SPEC-15</b>	<small>TP CENTRAL ODISHA DISTRIBUTION LIMITED</small>	<b>Date of Issue: 05/08/2020</b>

**1. SCOPE:**

This specification covers the technical requirements of design, manufacture, test at manufacturer's works, packing & forwarding, supply and unloading of bolted type eye hook at stores/site for efficient and trouble free operation.

**2. APPLICABLE STANDARDS:**

The equipment covered by this specification shall unless otherwise stated, be designed, manufactured and tested in accordance with the latest editions of the following Indian Standards and shall conform to the regulations of the local authorities:

- a) IS 2633: Specification for Hardware hot dip galvanizing & thickness of Zinc coating.

**3. CLIMATIC CONDITIONS OF THE INSTALLATION:**

The service conditions shall be as follows:

1. Maximum altitude above sea level 1,000m
2. Maximum ambient air temperature 50°C
3. Maximum daily average ambient air temperature 35°C
4. Minimum ambient air temperature 0°C
5. Maximum relative humidity 95%
6. Average number of thunderstorm days per annum (isokeraunic level) 70
7. Average number of rainy days per annum 120
8. Average annual rainfall 150cm
9. Earthquakes of an intensity in horizontal direction - equivalent to seismic acceleration of 0.3g
10. Earthquakes of an intensity in vertical direction - equivalent to seismic acceleration of 0.15g (g being acceleration due to gravity)
11. Wind velocity: 300 km/hr, 200 km/hr and 160 km/hr.

Environmentally, some of the regions, where the work will take place includes coastal areas, subject to high relative humidity, which can give rise to condensation. Onshore winds will frequently be salt laden. On occasions, the combination of salt and condensation may create pollution conditions for outdoor insulators. Some places are in heavily industrial polluted areas.

Therefore, Outdoor material and equipment shall be designed and protected for use in exposed, heavily polluted, salty, corrosive and humid coastal atmosphere

Rev No.	Description	Prepared By & Date	Checked By & Date	Approved for Issue By & Date
RO	Specification for Eye hook for LT PSC Pole	Suchismita Nayak	Niranjan Khuntia	Pourush Garg
		05/08/2020	05/08/2020	05/08/2020

<b>TP Central Odisha Distribution Limited</b>	 TP CENTRAL ODISHA DISTRIBUTION LIMITED	<b>Specification for Eye hook for LT PSC Pole</b>
<b>NEG-SPEC-15</b>		<b>Date of Issue: 05/08/2020</b>

The design of equipment and accessories shall be suitable to withstand seismic forces corresponding to an acceleration of 0.1 g

4. General Technical Requirements:

S. No	Description	Units	Requirement
1.	Application		To hold suspension clamp and Dead End clamp with pole
2.	Material		Hot dip galvanized Steel
3.	Ultimate Tensile Strength, Min	KN	20

5. General Constructions:

- a) Eye hook is used to hold suspension clamp and Dead End clamp and to be installed with the pole.
- b) Eye hook should be made of forged galvanized steel with M16 dia.
- c) Ultimate tensile strength of the bolted eye hook should not be less than 20 KN.
- d) Eye hook, bolts & washers shall be hot dip galvanized with uniform zinc coating.

6. TESTS:

Following tests for Eye hook should be done as per relevant IS.

- a) Ultimate Tensile Strength Test.
- b) Hot dip galvanization test

7. TYPE TEST CERTIFICATES:

The bidder shall furnish the type test certificates of the eye hook for the tests as mentioned as above as per the corresponding standards. All the tests shall be conducted by CPRI/ERDA Accredited laboratory as per the relevant standards. Type test should have been conducted in certified Test Laboratories during the period not exceeding 5 years from the date of opening the bid. In the event of any discrepancy in the test reports i.e. any test report not acceptable or any/all type tests (including additional type tests, if any) not carried out, same shall be carried out without any cost implication to TPCL.

8. EYE HOOKS

- a) Eye hooks shall be as per REC construction standard E-35 (Type – A)
- b) It should be made of forged hot dip galvanized steel as per IS-1570
- c) The clamp corrosion resistance should conform to standards IS 2629 & IS 2633. d) Minimum breaking Load should be 20 KN.

Rev No.	Description	Prepared By & Date	Checked By & Date	Approved for Issue By & Date
RO	Specification for Eye hook for LT PSC Pole	Suchismita Nayak	Niranjan Khuntia	Pourush Garg
		05/08/2020	05/08/2020	05/08/2020



<b>TP Central Odisha Distribution Limited</b>	 <b>TPCODL</b> <small>TP CENTRAL ODISHA DISTRIBUTION LIMITED</small>	<b>Specification for Eye hook for LT PSC Pole</b>
<b>NEG-SPEC-15</b>		<b>Date of Issue: 05/08/2020</b>

8.1 Type Test For Eye hooks, the Type Test Report s should be submitted from an Independent NABL Accredited Laboratory / CPRI as REC Spec-32/1984 & 84/2010 and as per relevant IS Specifications.

### 8.2 Acceptance Tests

The Acceptance Tests & sampling plan to be conducted as per REC Spec. 32/ 1984. & 84/2010 and as per relevant IS Specifications.

### 8.3 Drawings & Samples:

GA drawing and other particulars along with samples are to be submitted along with offer

### *Guaranteed Technical Particulars of Eye Hook*

Sl. No.	Description	Guaranteed Technical Particulars submitted by Vendors
1	Name and Address of the Manufacturer	
2	Type of Hooks	
3	Maximum weight span for 4x95's Maximum weight span for 4x50's	
4	Horizontal pull out load	
5	Types of Facades for which it is suitable	
6	Stand off from Facade	
7	Method of fixing to Façade	
8	Installation(with/without disassembly)	
9	Type and grade of Metallic Material	
10	Type of Hot Dip Galvanizing Thickness of Zinc Coating	
11	Markings:- As specified in IEC - 947	
12	Dimensions	

Rev No.	Description	Prepared By & Date	Checked By & Date	Approved for Issue By & Date
RO	Specification for Eye hook for LT PSC Pole	Suchismita Nayak	Niranjan Khuntia	Pourush Garg
		05/08/2020	05/08/2020	05/08/2020



<b>TP Central Odisha Distribution Limited</b>	<b>TPCODL</b> <small>TP CENTRAL ODISHA DISTRIBUTION LIMITED</small>	<b>Specification for Eye hook for LT PSC Pole</b>
<b>NEG-SPEC-15</b>		<b>Date of Issue: 05/08/2020</b>

13	Net Weight	
14	Ultimate tensile strength	
15	Acceptance tests	

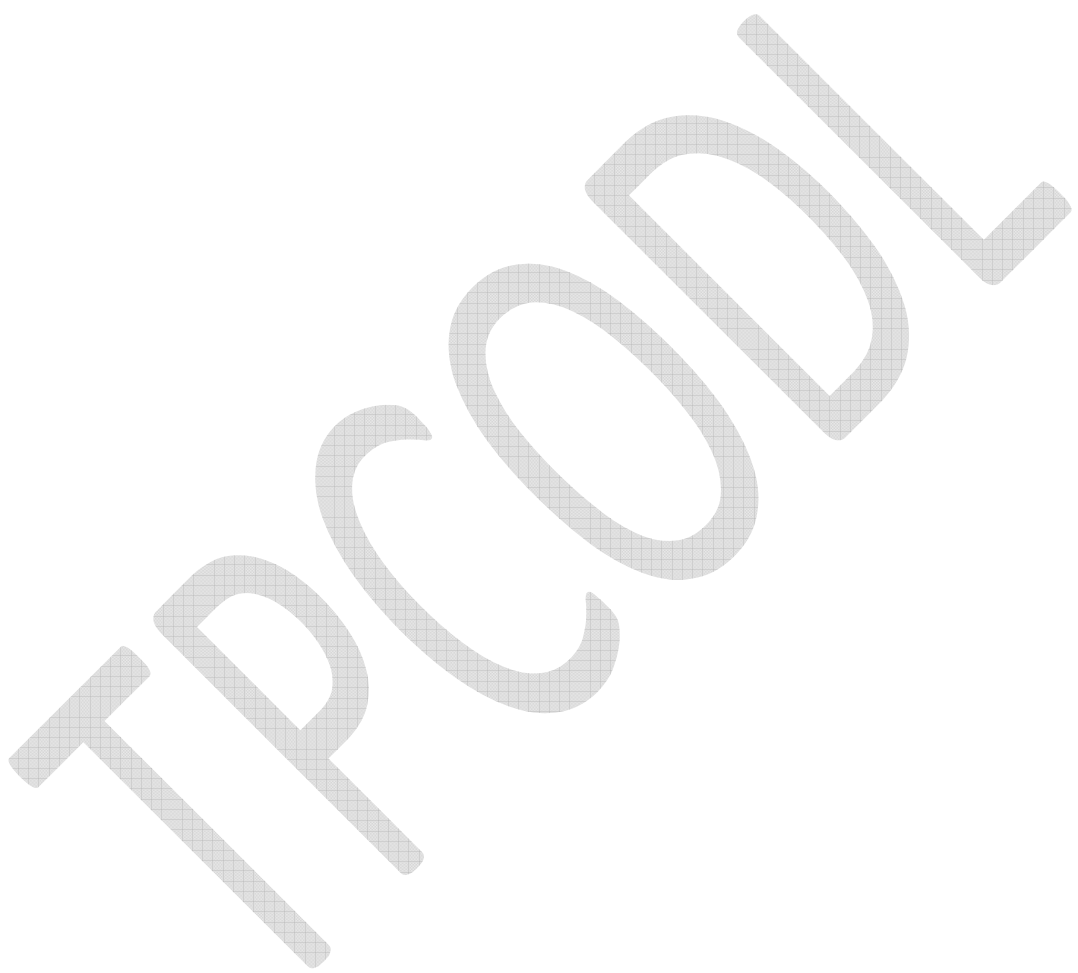

Rev No.	Description	Prepared By & Date	Checked By & Date	Approved for Issue By & Date
R0	Specification for Eye hook for LT PSC Pole	Suchismita Nayak	Niranjan Khuntia	Pourush Garg
		05/08/2020	05/08/2020	05/08/2020

<b>TP Central Odisha Distribution Limited</b>	 <small>TP CENTRAL ODISHA DISTRIBUTION LIMITED</small>	<b>Specification for 11KV DO Fuse unit</b>
<b>NEG-SPEC-12</b>		<b>Date of Issue: 05/08/2020</b>

**Technical Specification  
For  
Specification for 11KV DO Fuse unit**

**TP Central Odisha Distribution Limited.  
Network Engineering Group  
2<sup>nd</sup> Floor, IDCO Tower  
Janpath, Bhubaneswar- 751022**

Rev No.	Description	Prepared By & Date	Checked By & Date	Approved for Issue By & Date
R0	Specification for 11KV DO Fuse unit	Suchismita Nayak	Niranjan Khuntia	Pourush Garg
		05/08/2020	05/08/2020	05/08/2020

<b>TP Central Odisha Distribution Limited</b>	 TP CENTRAL ODISHA DISTRIBUTION LIMITED	<b>Specification for 11KV DO Fuse unit</b>
<b>NEG-SPEC-12</b>		<b>Date of Issue: 05/08/2020</b>

## CONTENTS

- 1.0 SCOPE
- 2.0 APPLICABLE STANDARDS
- 3.0 CLIMATIC CONDITIONS OF THE INSTALLATION
- 4.0 GENERAL TECHNICAL REQUIREMENTS
- 5.0 GENERAL CONSTRUCTIONS
- 6.0 NAME PLATE AND MARKING
- 7.0 TESTS
- 8.0 TYPE TEST CERIFICATES
- 9.0 PRE-DISPATCH INSPECTION
- 10.0 INSPECTION AFTER RECEIPT AT STORE
- 11.0 GUARANTEE
- 12.0 PACKING
- 13.0 TENDER SAMPLE
- 14.0 TRAINING
- 15.0 QUALITY CONTROL
- 16.0 MINIMUM TESTING FACILITIES
- 17.0 MANUFACTURING ACTIVITIES
- 18.0 SPARES, ACCESSORIES AND TOOLS
- 19.0 DRAWING AND DOCUMENTS
- 20.0 GUARANTEED TECHNICAL PARTICULARS
- 21.0 SCHEDULE OF DEVIATIONS

Rev No.	Description	Prepared By & Date	Checked By & Date	Approved for Issue By & Date
RO	Specification for 11KV DO Fuse unit	Suchismita Nayak	Niranjan Khuntia	Pourush Garg
		05/08/2020	05/08/2020	05/08/2020

TP Central Odisha Distribution Limited	<b>TPCODL</b>	Specification for 11KV DO Fuse unit
NEG-SPEC-12	TP CENTRAL ODISHA DISTRIBUTION LIMITED	Date of Issue: 05/08/2020

### + Annexure: Inspection Test Plan

1.0	SCOPE	This specification covers technical requirements of design, manufacture, construction, performance, testing at manufacture's work, packing, forwarding, supply and unloading of 11Kv, 200 Amps Silicon Rubber DO Fuse at stores/site complete with all accessories for efficient and trouble free-operation. The specific requirements are covered in enclosed technical data sheet	
2.0	APPLICABLE STANDARDS	'DO FUSE' covered by this specification shall unless otherwise stated, be designed, manufactured and tested in accordance with latest revisions of relevant Indian Standards /IEC/ International Standards and shall conform to the regulations of local statutory authorities.	
		IS 9385 (Part-1)	Specification for high voltage fuse Part 1 – Current Limiting Fuse
		IS 9385 (Part-2)	Specification for high voltage fuse Part 1 – Expulsion and similar fuses
		IS 9385 (Part-3)	Specification for high voltage fuse Part 1 – Application for high voltage fuses
		IS 3400-1: 2012	Methods of test for vulcanized rubbers; Part1 Rubber, Vulcanized—Determination of Tensile Stress-Strain Properties ( Third Revision )
		IS 3400-2: 2003	Methods of test for vulcanized rubbers; Part2 Rubber, Vulcanized or thermoplastic- Determination of Hardness (Hardness between 10 IRHD and 100 IRHD)
		IS 3400-9: 2003	Methods of test for vulcanized rubbers; Part9 Rubber, Vulcanized—Determination of Density (Second Revision )
		IS 6746 : 1994	Unsaturated polyester resin systems - specification
		IEC 61109:2008	<i>Insulators for overhead lines - Composite suspension and tension insulators for a.c. systems with a nominal voltage greater than 1 000 V - Definitions, test methods and acceptance criteria</i>
		IS 2633 : 1986	Method for Testing Uniformity of Coating on Zinc coated Articles ( Second Revision )
		IS: 1364-2002	Hexagon Head Bolts, Screws and Nuts of Product Grades A and B
		IEC 60587	Electrical insulating materials used under severe ambient conditions – Test methods for evaluating resistance to tracking and erosion
IEC 62217 : 2005	Polymeric insulator for indoor and outdoor use with a nominal >1000v – General definition, test methods & acceptance criteria		

Rev No.	Description	Prepared By & Date	Checked By & Date	Approved for Issue By & Date
RO	Specification for 11KV DO Fuse unit	Suchismita Nayak	Niranjan Khuntia	Pourush Garg
		05/08/2020	05/08/2020	05/08/2020

<b>TP Central Odisha Distribution Limited</b>	 TP CENTRAL ODISHA DISTRIBUTION LIMITED	<b>Specification for 11KV DO Fuse unit</b>
<b>NEG-SPEC-12</b>		<b>Date of Issue: 05/08/2020</b>

		<table border="1"> <tr> <td>IEC 60282 - 1</td> <td>High Voltage Fuses- Part 1: Current Limiting Fuses</td> </tr> <tr> <td>IEC 60282 - 2</td> <td>High-voltage fuses - Part 2: Expulsion fuses</td> </tr> <tr> <td>ANSI C 29</td> <td>Test methods for electrical power insulators</td> </tr> </table> <p><i>*In case of any conflict on any technical particular in the specification, the stricter requirement mentioned in the relevant standard shall be valid.</i></p>	IEC 60282 - 1	High Voltage Fuses- Part 1: Current Limiting Fuses	IEC 60282 - 2	High-voltage fuses - Part 2: Expulsion fuses	ANSI C 29	Test methods for electrical power insulators
IEC 60282 - 1	High Voltage Fuses- Part 1: Current Limiting Fuses							
IEC 60282 - 2	High-voltage fuses - Part 2: Expulsion fuses							
ANSI C 29	Test methods for electrical power insulators							
<b>3.0</b>	<b>CLIMATIC CONDITIONS OF THE INSTALLATION</b>	<p>The material shall be suitable for following climatic conditions,</p> <ol style="list-style-type: none"> <li>1. Maximum altitude above sea level 1,000m</li> <li>2. Maximum ambient air temperature 50°C</li> <li>3. Maximum daily average ambient air temperature 35°C</li> <li>4. Minimum ambient air temperature 0°C</li> <li>5. Maximum relative humidity 95%</li> <li>6. Average number of thunderstorm days per annum (isokeraunic level) 70</li> <li>7. Average number of rainy days per annum 120</li> <li>8. Average annual rainfall 150cm</li> <li>9. Earthquakes of an intensity in horizontal direction - equivalent to seismic acceleration of 0.3g</li> <li>10. Earthquakes of an intensity in vertical direction - equivalent to seismic acceleration of 0.15g (g being acceleration due to gravity)</li> <li>11. Wind velocity: 300 km/hr, 200 km/hr and 160 km/hr.</li> </ol> <p>Environmentally, some of the regions, where the work will take place includes coastal areas, subject to high relative humidity, which can give rise to condensation. Onshore winds will frequently be salt laden. On occasions, the combination of salt and condensation may create pollution conditions for outdoor insulators. Some places are in heavily industrial polluted areas.</p> <p>Therefore, Outdoor material and equipment shall be designed and protected for use in exposed, heavily polluted, salty, corrosive and humid coastal atmosphere</p> <p>The design of equipment and accessories shall be suitable to withstand seismic forces corresponding to an acceleration of 0.1 g.</p>						

Rev No.	Description	Prepared By & Date	Checked By & Date	Approved for Issue By & Date
RO	Specification for 11KV DO Fuse unit	Suchismita Nayak	Niranjan Khuntia	Pourush Garg
		05/08/2020	05/08/2020	05/08/2020

<b>TP Central Odisha Distribution Limited</b>	 <b>TPCODL</b> <small>TP CENTRAL ODISHA DISTRIBUTION LIMITED</small>	<b>Specification for 11KV DO Fuse unit</b>
<b>NEG-SPEC-12</b>		<b>Date of Issue: 05/08/2020</b>

<b>4.0</b>	<b>GENERAL TECHNICAL REQUIREMENTS</b>	S.no	Description	unit	Requirement
		1	Type		Expulsion, Class-2
		2	Rated Voltage	KV	12
		3	Service Voltage	KV	11
		4	Rated Frequency	Hz	50
		5	No. of Phases		3
		6	Current Rating	Amps	200
		7	Rated Breaking Capacity	kA	10
		8	Max. Switching Voltage	kV (max.)	38
		9	Minimum creepage distance	mm	320
		10	Rated lightning impulse withstand voltage to earth & between poles.	kV (Peak)	75
		11	Rated lightning impulse withstand voltage across the isolating distance	kV (Peak)	85
		12	Rated one minute power frequency-withstand voltage to earth & between poles.	kV (rms)	28
		13	Rated one minute power frequency-withstand voltage across the isolating distance.	kV (rms)	32
		14	Max. Permissible temperature rise at an ambient temp. not exceeding 40°	°C	65
		15	Minimum Creepage distance	mm	320
		16	Length of Fuse holder	mm	285±2
		17	Minimum Thickness of galvanization at any point of measurement	microns	6
		18	Outer diameter of the fuse link	mm	12±0.5
		19	Length of the fiber glass tube of the fuse link	mm	140
		20	Material of the fuse link tube		Fiber with flame retardant properties
		21	Material of the fuse element		Tinned copper
		22	Material of the flexible wire		Tinned copper
		23	Inner diameter of the fuse holder Tube	mm	14±1
		24	Outer diameter of the fuse holder	mm	25±0.5
		25	Min overall length of the fuse link (with wire)	mm	510±1
		26	Diameter of the washer	mm	19±0.5
		27	Maximum thickness of bending section( at any point of measurement)	mm	4
28	Transient Recovery Voltage (TRV)		As per IEC 60282		

Rev No.	Description	Prepared By & Date	Checked By & Date	Approved for Issue By & Date
RO	Specification for 11KV DO Fuse unit	Suchismita Nayak	Niranjan Khuntia	Pourush Garg
		05/08/2020	05/08/2020	05/08/2020

<b>TP Central Odisha Distribution Limited</b>	<b>TPCODL</b>  TP CENTRAL ODISHA DISTRIBUTION LIMITED	<b>Specification for 11KV DO Fuse unit</b>
<b>NEG-SPEC-12</b>		<b>Date of Issue: 05/08/2020</b>

		<table border="1"> <tr> <td>29</td> <td>Diameter of solid FRP rod used for insulation</td> <td>mm</td> <td>24</td> </tr> <tr> <td>30</td> <td>Overall height of insulator including end terminals</td> <td>mm</td> <td>306+/- 6</td> </tr> <tr> <td>31</td> <td>Mechanical strength of polymeric insulation</td> <td>KN</td> <td>5</td> </tr> <tr> <td>32</td> <td>Area of Cross Section for Main Live parts</td> <td>mm<sup>2</sup></td> <td>To be specified by bidder</td> </tr> </table>	29	Diameter of solid FRP rod used for insulation	mm	24	30	Overall height of insulator including end terminals	mm	306+/- 6	31	Mechanical strength of polymeric insulation	KN	5	32	Area of Cross Section for Main Live parts	mm <sup>2</sup>	To be specified by bidder	
29	Diameter of solid FRP rod used for insulation	mm	24																
30	Overall height of insulator including end terminals	mm	306+/- 6																
31	Mechanical strength of polymeric insulation	KN	5																
32	Area of Cross Section for Main Live parts	mm <sup>2</sup>	To be specified by bidder																
<b>5.0</b>	<b>GENERAL CONSTRUCTION</b>	<p>The DO fuse unit shall be of single vent type (downward) having a front connected fuse carrier suitable for angle mounting. All ferrous metals parts, except those of stainless steel, shall be hot dip galvanized and the uniformity of the zinc coating shall satisfy the requirement of IS : 2633-1964. The parts shall be galvanized after machining as well. Nuts and bolts shall confirm to IS: 1364-2002. Spring washer shall also be galvanized.</p> <p><b>A. FUSE LINK</b></p> <table border="1"> <tr> <td>1.</td> <td>A Fuse link shall not emit flame, although a minor emission of flame from a sticker or indicating device is permissible, provided this does not cause breakdown or significant electrical leakage to earth.</td> </tr> <tr> <td>2.</td> <td>After the fuse has operated, the components of the fuse, apart from those intended to be replaced after each operation, shall be in the original state. It shall be possible to remove the fuse-link in one piece after operation</td> </tr> <tr> <td>3.</td> <td>The values of cut-off current corresponding to each value of prospective breaking current shall not exceed the values corresponding to the cut-off characteristics</td> </tr> <tr> <td>4.</td> <td>After operation, the fuse shall be capable of withstanding the power-frequency recovery voltage across its terminals</td> </tr> </table> <p><b>B. FUSE HOLDER</b></p> <table border="1"> <tr> <td>1.</td> <td>The fuse holder shall be made up of fiber glass coated with ultraviolet inhibitor on the other surface. The inside layer of fuse carrier shall be lined with special formulations for generation of arc quenching gases. The carrier shall have high bursting strength to sustain high pressure of the gases during the fault interruption.</td> </tr> <tr> <td>2.</td> <td>The fuse holder top contact shall have a solid replaceable cap made of tinned plated brass.</td> </tr> <tr> <td>3.</td> <td>The installation and removal of the fuse holder should be facilitated by inserting the operating rod into lifting eye at lower hinge end when the holder is in dropped out position. An operating eye hook shall be provided at the top of the fuse holder to facilitate downward pull by the operating rod to release the latch incorporated in stationary upper contact.</td> </tr> <tr> <td>4.</td> <td>The upper stationary contact assembly shall be provided with a safety latch and the hinge at lower stationary contact shall be so designed to prevent fuse holder</td> </tr> </table>		1.	A Fuse link shall not emit flame, although a minor emission of flame from a sticker or indicating device is permissible, provided this does not cause breakdown or significant electrical leakage to earth.	2.	After the fuse has operated, the components of the fuse, apart from those intended to be replaced after each operation, shall be in the original state. It shall be possible to remove the fuse-link in one piece after operation	3.	The values of cut-off current corresponding to each value of prospective breaking current shall not exceed the values corresponding to the cut-off characteristics	4.	After operation, the fuse shall be capable of withstanding the power-frequency recovery voltage across its terminals	1.	The fuse holder shall be made up of fiber glass coated with ultraviolet inhibitor on the other surface. The inside layer of fuse carrier shall be lined with special formulations for generation of arc quenching gases. The carrier shall have high bursting strength to sustain high pressure of the gases during the fault interruption.	2.	The fuse holder top contact shall have a solid replaceable cap made of tinned plated brass.	3.	The installation and removal of the fuse holder should be facilitated by inserting the operating rod into lifting eye at lower hinge end when the holder is in dropped out position. An operating eye hook shall be provided at the top of the fuse holder to facilitate downward pull by the operating rod to release the latch incorporated in stationary upper contact.	4.	The upper stationary contact assembly shall be provided with a safety latch and the hinge at lower stationary contact shall be so designed to prevent fuse holder
1.	A Fuse link shall not emit flame, although a minor emission of flame from a sticker or indicating device is permissible, provided this does not cause breakdown or significant electrical leakage to earth.																		
2.	After the fuse has operated, the components of the fuse, apart from those intended to be replaced after each operation, shall be in the original state. It shall be possible to remove the fuse-link in one piece after operation																		
3.	The values of cut-off current corresponding to each value of prospective breaking current shall not exceed the values corresponding to the cut-off characteristics																		
4.	After operation, the fuse shall be capable of withstanding the power-frequency recovery voltage across its terminals																		
1.	The fuse holder shall be made up of fiber glass coated with ultraviolet inhibitor on the other surface. The inside layer of fuse carrier shall be lined with special formulations for generation of arc quenching gases. The carrier shall have high bursting strength to sustain high pressure of the gases during the fault interruption.																		
2.	The fuse holder top contact shall have a solid replaceable cap made of tinned plated brass.																		
3.	The installation and removal of the fuse holder should be facilitated by inserting the operating rod into lifting eye at lower hinge end when the holder is in dropped out position. An operating eye hook shall be provided at the top of the fuse holder to facilitate downward pull by the operating rod to release the latch incorporated in stationary upper contact.																		
4.	The upper stationary contact assembly shall be provided with a safety latch and the hinge at lower stationary contact shall be so designed to prevent fuse holder																		

Rev No.	Description	Prepared By & Date	Checked By & Date	Approved for Issue By & Date
RO	Specification for 11KV DO Fuse unit	Suchismita Nayak 05/08/2020	Niranjan Khuntia 05/08/2020	Pourush Garg 05/08/2020



<b>TP Central Odisha Distribution Limited</b>	<b>TPCODL</b>	<b>Specification for 11KV DO Fuse unit</b>
<b>NEG-SPEC-12</b>	TP CENTRAL ODISHA DISTRIBUTION LIMITED	<b>Date of Issue: 05/08/2020</b>

	<p>from dropping due to vibration.</p> <p>5. The lower contact shall be capable of absorbing the shock when the fuse carrier is pushed into the closed position and shall not allow the fuse link to be damaged ( specially when link is of low ampere rating).</p> <p>6. The lower contact shall keep the fuse link in the center of the fuse holder and keep it tensioned under all operating conditions.</p> <p>7. The top metal button of the fuse carrier shall be designed such that this can accommodate the fuse link supporting washer of 19±0.5 mm outer diameter</p>						
	<p><b>C. POLYMERIC INSULATOR</b></p> <p>1. The solid FRP rod shall be manufactured from boron free, electricity corrosion resistance (ECR) grade class fiber reinforced epoxy resin, having at least 70% fiber by weight.</p> <p>2. The top and bottom current carrying parts shall be made of highly conductive copper alloy (99.9% pure) and the contact portion shall be tin plated for corrosion resistance and efficient current flow. The top contact shall have a socket cavity for latching and holding firmly the fuse holder</p> <p>3. The top assembly shall be robust enough to absorb bulk of the forces during the fuse carrier closing and opening operation and shall not over stress the spring contact. It shall also prohibit accidental opening of the fuse holder due to vibration impact.</p> <p>4. The bottom assembly shall have hinge contacts made from highly conductive, anti-corrosive copper alloy and shall accommodate and make a firm contact with the fuse holder bottom assembly. The fuse holder shall be prevented from slipping out of the self-locking hinges during all operating conditions and only when the fuse holder has reached it's fully open position can it be removed from the hinge support.</p> <p>5. The insulator shall be a bird proof , single unit silicon rubber insulator with a creepage distance (to earth) not less than 320 mm. the top and bottom assemblies as also the middle clamping hard wares, shall be fitted suitably through riveting so as to provided strong clamping arrangements in suitable position. For such components, the pull out strength should be such as to result in breaking of the insulator/FRP rod before pull out occurs in a test.</p>						
	<p><b>D. TERMINALS</b></p> <p>1. The upper and lower terminals shall be provided in tin plated copper to provide low resistance current path.</p> <p>2. Copper strip in the upper contact plate shall be single strip</p>						
	<p><b>E. FUSE BARREL STICKERS</b></p> <p>1. Stickers shall have non fading and UV resistant colors so that there is no effect of sunlight.</p> <p>2. They shall be of good adhesive quality so that they do not peel off in outdoor conditions.</p> <p>3. The pigmentation shall be of florescent nature to allow visibility during night time.</p> <p>4. The sticker color for various fuse current shall be as per following:</p> <table border="1"> <thead> <tr> <th>S.no.</th> <th>Fuse current rating</th> <th>Color</th> </tr> </thead> <tbody> <tr> <td>1.</td> <td>2A</td> <td>Yellow (equivalent to shade 309 of IS:5 or RAL 1003)</td> </tr> </tbody> </table>	S.no.	Fuse current rating	Color	1.	2A	Yellow (equivalent to shade 309 of IS:5 or RAL 1003)
S.no.	Fuse current rating	Color					
1.	2A	Yellow (equivalent to shade 309 of IS:5 or RAL 1003)					

Rev No.	Description	Prepared By & Date	Checked By & Date	Approved for Issue By & Date
RO	Specification for 11KV DO Fuse unit	Suchismita Nayak 05/08/2020	Niranjan Khuntia 05/08/2020	Pourush Garg 05/08/2020



<b>TP Central Odisha Distribution Limited</b>	 <b>TPCODL</b> <small>TP CENTRAL ODISHA DISTRIBUTION LIMITED</small>	<b>Specification for 11KV DO Fuse unit</b>
<b>NEG-SPEC-12</b>		<b>Date of Issue: 05/08/2020</b>

			2. 5A	Red (equivalent to shade 537 of IS:5 or RAL 3001)
			3. 8A	TATA POWER –DOL Blue (PANTON E2727C)
			4. 10A	Green (equivalent to RAL6024)
			5. 20A	White (equivalent to RAL9003)
			6. 30A	Pink (equivalent to shade 442 of IS:5 or RAL 3015)
<b>6.0</b>	<b>NAME PLATE AND MARKING</b>	<p>The identifying markings which shall be indelibly marked on fuse-links and fuse-holder are given below:</p> <p>on Fuse Link:</p> <ol style="list-style-type: none"> <li>1. Manufacturer's name</li> <li>2. Rated voltage</li> <li>3. Rated current</li> <li>4. Rated maximum breaking current</li> </ol> <p>On Fuse Holder:</p> <ol style="list-style-type: none"> <li>1. Manufacturer's name</li> <li>2. Rated voltage</li> <li>3. Rated current</li> <li>4. Rated maximum breaking current</li> <li>5. PO no.</li> <li>6. Property of "TPCL, BHUBANESWAR"</li> <li>7. Date of Manufacturing</li> <li>8. BIS certification mark</li> </ol> <p>The identifying markings which shall be indelibly marked on polymeric insulator are given below:</p> <ol style="list-style-type: none"> <li>1. Manufacturer's name</li> <li>2. Rated voltage</li> <li>3. Rated current</li> <li>4. Rated maximum breaking current</li> <li>5. PO no.</li> <li>6. Property of "TPCL, BHUBANESWAR"</li> <li>7. Date of Manufacturing</li> <li>8. BIS certification mark</li> </ol>		

Rev No.	Description	Prepared By & Date	Checked By & Date	Approved for Issue By & Date
RO	Specification for 11KV DO Fuse unit	Suchismita Nayak	Niranjan Khuntia	Pourush Garg
		05/08/2020	05/08/2020	05/08/2020

<b>TP Central Odisha Distribution Limited</b>	<b>TPCODL</b>	<b>Specification for 11KV DO Fuse unit</b>
<b>NEG-SPEC-12</b>	TP CENTRAL ODISHA DISTRIBUTION LIMITED	<b>Date of Issue: 05/08/2020</b>

<b>7.0</b>	<b>TESTS</b>	Routine, Acceptance & Type tests shall be carried out in accordance with the relevant IS/IEC/ International standard. Acceptance tests shall be witnessed by TPCL's authorized representative. Following tests shall be necessarily conducted on the <b>DO Fuse</b> in additions to others specified in IS/IEC/ANSI standards. Type tests shall be conducted from CPRI/ERDA only. <i>*In case of any conflict on any technical particular in the specification, the stricter requirement mentioned in the relevant standard shall be valid.</i>																											
		<table border="1"> <thead> <tr> <th>S.no.</th> <th>Type Test for Fuse Link</th> <th>Reference standard</th> </tr> </thead> <tbody> <tr> <td>1</td> <td>Time Current Characteristic</td> <td>IEC 60282-1</td> </tr> <tr> <td>2</td> <td>Measurement of resistance</td> <td>IEC 60282-1</td> </tr> <tr> <td>3</td> <td>Cut – off Characteristic</td> <td>IEC 60282-1</td> </tr> <tr> <td>4</td> <td>Flammability test on FRP Tube</td> <td>ANNEX N of IS 6746 : 1994</td> </tr> </tbody> </table>	S.no.	Type Test for Fuse Link	Reference standard	1	Time Current Characteristic	IEC 60282-1	2	Measurement of resistance	IEC 60282-1	3	Cut – off Characteristic	IEC 60282-1	4	Flammability test on FRP Tube	ANNEX N of IS 6746 : 1994												
		S.no.	Type Test for Fuse Link	Reference standard																									
		1	Time Current Characteristic	IEC 60282-1																									
		2	Measurement of resistance	IEC 60282-1																									
		3	Cut – off Characteristic	IEC 60282-1																									
		4	Flammability test on FRP Tube	ANNEX N of IS 6746 : 1994																									
		<table border="1"> <thead> <tr> <th>S.no.</th> <th>Type Test for Fuse Holder</th> <th>Reference standard</th> </tr> </thead> <tbody> <tr> <td>1</td> <td>Dimension check</td> <td>As per clause no. 4 of technical specification ENG-XX-XXX</td> </tr> <tr> <td>2</td> <td>Breaking capacity test</td> <td>IS 9385-II, clause No. 7.5 &amp; IEC 60282-1, Clause No. 6.6</td> </tr> <tr> <td>3</td> <td>Flammability test</td> <td>ANNEX N of IS 6746 : 1994</td> </tr> </tbody> </table>	S.no.	Type Test for Fuse Holder	Reference standard	1	Dimension check	As per clause no. 4 of technical specification ENG-XX-XXX	2	Breaking capacity test	IS 9385-II, clause No. 7.5 & IEC 60282-1, Clause No. 6.6	3	Flammability test	ANNEX N of IS 6746 : 1994															
		S.no.	Type Test for Fuse Holder	Reference standard																									
		1	Dimension check	As per clause no. 4 of technical specification ENG-XX-XXX																									
		2	Breaking capacity test	IS 9385-II, clause No. 7.5 & IEC 60282-1, Clause No. 6.6																									
		3	Flammability test	ANNEX N of IS 6746 : 1994																									
		<table border="1"> <thead> <tr> <th>S.no.</th> <th>Type Test for Polymeric insulator</th> <th>Reference standard</th> </tr> </thead> <tbody> <tr> <td>1</td> <td>Chemical composition of Silicone Content</td> <td>Annexure – B as per EDX/Thermo gravimetric method</td> </tr> <tr> <td>2</td> <td>Recover of hydrophobicity test</td> <td>Annexure – B as per STRI guide</td> </tr> <tr> <td>3</td> <td>Accelerated weathering Test for 1000 hrs (UV Test)</td> <td>As per IEC 61109 &amp; 62217</td> </tr> <tr> <td>4</td> <td>Tracking &amp; Erosion Test for 1000 hrs</td> <td>As per IEC 61109 &amp; 62217</td> </tr> <tr> <td>5</td> <td>Dye Penetration Test (Core Materials)</td> <td>As per IEC 61109 &amp; 62217</td> </tr> <tr> <td>6</td> <td>Water Diffusion Test (Core Materials)</td> <td>As per IEC 61109 &amp; 62217</td> </tr> <tr> <td>7</td> <td>Brittle Fracture Resistance Test</td> <td>As per REC Specifications.</td> </tr> <tr> <td>8</td> <td>Tensile stress strain test</td> <td>IS 3400 - 1</td> </tr> </tbody> </table>	S.no.	Type Test for Polymeric insulator	Reference standard	1	Chemical composition of Silicone Content	Annexure – B as per EDX/Thermo gravimetric method	2	Recover of hydrophobicity test	Annexure – B as per STRI guide	3	Accelerated weathering Test for 1000 hrs (UV Test)	As per IEC 61109 & 62217	4	Tracking & Erosion Test for 1000 hrs	As per IEC 61109 & 62217	5	Dye Penetration Test (Core Materials)	As per IEC 61109 & 62217	6	Water Diffusion Test (Core Materials)	As per IEC 61109 & 62217	7	Brittle Fracture Resistance Test	As per REC Specifications.	8	Tensile stress strain test	IS 3400 - 1
		S.no.	Type Test for Polymeric insulator	Reference standard																									
		1	Chemical composition of Silicone Content	Annexure – B as per EDX/Thermo gravimetric method																									
2	Recover of hydrophobicity test	Annexure – B as per STRI guide																											
3	Accelerated weathering Test for 1000 hrs (UV Test)	As per IEC 61109 & 62217																											
4	Tracking & Erosion Test for 1000 hrs	As per IEC 61109 & 62217																											
5	Dye Penetration Test (Core Materials)	As per IEC 61109 & 62217																											
6	Water Diffusion Test (Core Materials)	As per IEC 61109 & 62217																											
7	Brittle Fracture Resistance Test	As per REC Specifications.																											
8	Tensile stress strain test	IS 3400 - 1																											
<table border="1"> <thead> <tr> <th>S.no.</th> <th>Type Test for Complete Assembly</th> <th>Reference standard</th> </tr> </thead> <tbody> <tr> <td>1</td> <td>Temperature-rise tests and power-dissipation measurement</td> <td>IS 9385-II, clause No. 7.4 &amp; IEC 60282-1, Clause No. 6.5</td> </tr> <tr> <td>2</td> <td>Breaking test</td> <td>IS 9385-II, clause No. 7.5 &amp; IEC 60282-1, Clause No. 6.6</td> </tr> <tr> <td>3</td> <td>Tests for time-current characteristic</td> <td>IS 9385-II, clause No. 7.6 &amp; IEC 60282-1, Clause No. 6.7</td> </tr> <tr> <td>4</td> <td>Dielectric test</td> <td>IS 9385-II, clause No. 7.3 &amp; IEC 60282-1, Clause No. 6.4</td> </tr> <tr> <td>5</td> <td>Tests of strikers</td> <td>IEC 60282-1, Clause No. 6.8</td> </tr> <tr> <td>6</td> <td>Dry Lighting impulse withstand voltage test</td> <td>IEC 61109:2008</td> </tr> <tr> <td>7</td> <td>Wet power frequency test</td> <td>IEC 61109:2008</td> </tr> <tr> <td>8</td> <td>Dry power frequency test</td> <td>IEC 61109:2008</td> </tr> </tbody> </table>	S.no.	Type Test for Complete Assembly	Reference standard	1	Temperature-rise tests and power-dissipation measurement	IS 9385-II, clause No. 7.4 & IEC 60282-1, Clause No. 6.5	2	Breaking test	IS 9385-II, clause No. 7.5 & IEC 60282-1, Clause No. 6.6	3	Tests for time-current characteristic	IS 9385-II, clause No. 7.6 & IEC 60282-1, Clause No. 6.7	4	Dielectric test	IS 9385-II, clause No. 7.3 & IEC 60282-1, Clause No. 6.4	5	Tests of strikers	IEC 60282-1, Clause No. 6.8	6	Dry Lighting impulse withstand voltage test	IEC 61109:2008	7	Wet power frequency test	IEC 61109:2008	8	Dry power frequency test	IEC 61109:2008		
S.no.	Type Test for Complete Assembly	Reference standard																											
1	Temperature-rise tests and power-dissipation measurement	IS 9385-II, clause No. 7.4 & IEC 60282-1, Clause No. 6.5																											
2	Breaking test	IS 9385-II, clause No. 7.5 & IEC 60282-1, Clause No. 6.6																											
3	Tests for time-current characteristic	IS 9385-II, clause No. 7.6 & IEC 60282-1, Clause No. 6.7																											
4	Dielectric test	IS 9385-II, clause No. 7.3 & IEC 60282-1, Clause No. 6.4																											
5	Tests of strikers	IEC 60282-1, Clause No. 6.8																											
6	Dry Lighting impulse withstand voltage test	IEC 61109:2008																											
7	Wet power frequency test	IEC 61109:2008																											
8	Dry power frequency test	IEC 61109:2008																											

Rev No.	Description	Prepared By & Date	Checked By & Date	Approved for Issue By & Date
RO	Specification for 11KV DO Fuse unit	Suchismita Nayak 05/08/2020	Niranjan Khuntia 05/08/2020	Pourush Garg 05/08/2020

<b>TP Central Odisha Distribution Limited</b>	 <b>TPCODL</b> TP CENTRAL ODISHA DISTRIBUTION LIMITED	<b>Specification for 11KV DO Fuse unit</b>
<b>NEG-SPEC-12</b>		<b>Date of Issue: 05/08/2020</b>

		9	UV test	ANSI C 29
		S.no.	Special Test	Reference standard
		1	thermal shock test	As per IEC 60282-1, Clause NO. 7.3 (For Fuse Link only)
		2	Power dissipation test	As per IEC 60282-1, Clause NO. 7.4 (For Fuse Link only)
		c.	Water-Ingress Test	Not Applicable for Button Type Fuse
		S.no.	Routine Test	Reference standard
		1	Dimension test	As per clause no. 4 of the technical specification ENG-XXX-XXXX
		2	Visual Inspection	As per clause no. 5 of the technical specification ENG-XXX-XXXX
		3	Dry power frequency test	IEC 61109:2008
		S.no.	Acceptance Test	Reference standard
		1	Dimension test	As per clause no. 4 of the technical specification ENG-XXX-XXXX
		2	Time Current Characteristic	IS 9385-II, clause No. 7.6 & IEC 60282-1, Clause No. 6.7
		3	Temperature-Rise Test	IS 9385-II, clause No. 7.4 & IEC 60282-1, Clause No. 6.5
		4	Power frequency Voltage Withstand Test	IS 9385-II, clause No. 7.3.6 & IEC 60282- 1, Clause No. 6.4.5
		5	Tests of strikers	IEC 60282-1, Clause No. 6.8
		6	Wet power frequency test	IEC 61109:2008
<b>8.0</b>	<b>TYPE TEST CERTIFICATE S</b>	<p><b>Requirement:</b> Bidder shall furnish the type test report of DO Fuse for the tests as mentioned in Clause no. 7 of this specification and as per reference standards.</p> <p><b>Test Laboratories:</b> Complete set of Type Tests shall be conducted at certified test laboratories, which are CPRI/ERDA only.</p> <p>Type test report shall be submitted for the type, size and rating of the DO Fuse mentioned in the bid/ OR for any size higher (than required) of similar type and similar or higher voltage grade. <b>Type test should have been conducted in certified test laboratories during the period not exceeding 5 years from the date of opening the bid.</b> In the event of any discrepancy in the test reports i.e. any test report not acceptable or any/all type tests (including additional type tests, if any) not carried out, same shall be carried out without any cost implication to TPCL. In case the type test certificates are dated beyond 5 years and up to 10 years maintaining basic component design same then deviation should be submitted on vendor letter head. TPCL will have the rights to accept/reject the same.</p>		
<b>9.0</b>	<b>PRE- DISPATCH INSPECTION</b>	<p>Inspection shall be carried out by duly authorized representative of TPCL. Bidder shall grant free access to the places of manufacture to TPCL's representatives at all times when the work is in progress. Inspection may be made at any stage of manufacturing at the discretion of TPCL and the equipment, if found unsatisfactory as to workmanship or material, the same is liable to rejection. Inspection by TPCL or its authorized representatives shall not relieve the bidder of his obligation of furnishing equipment in accordance with the specifications. One copy of the report</p>		

Rev No.	Description	Prepared By & Date	Checked By & Date	Approved for Issue By & Date
RO	Specification for 11KV DO Fuse unit	Suchismita Nayak	Niranjan Khuntia	Pourush Garg
		05/08/2020	05/08/2020	05/08/2020

<b>TP Central Odisha Distribution Limited</b>		<b>Specification for 11KV DO Fuse unit</b>
<b>NEG-SPEC-12</b>	<small>TP CENTRAL ODISHA DISTRIBUTION LIMITED</small>	<b>Date of Issue: 05/08/2020</b>

		shall be sent to Contracts & Engineering department.  <b>Dispatch of material:</b> Material shall be dispatched after specific MDCC (Material Dispatch Clearance Certificate) is issued by TPCL. Following documents shall be sent along with the supplied material: a) Test reports b) MDCC issued by TPCL c) Invoice in duplicate d) Packing list e) Delivery Challan
<b>10.0</b>	<b>INSPECTION AFTER RECEIPT AT STORES</b>	The material received at TPCL, Bhubaneswar, Odisha store shall be inspected for acceptance and shall be liable for rejection, if found different from the reports of the pre-dispatch inspection.
<b>11.0</b>	<b>GUARANTEE</b>	<b>Requirement:</b> Bidder shall confirm for guarantee towards design, material, workmanship & quality of process / manufacturing for integrated product delivered under the contract. In the event any defect is found by TPCL, up to a period of at least 12 months from the date of commissioning or 24 months from the date of last supplies made under the contract whichever is later, bidder shall be liable to undertake to replace/rectify such defects at its own costs, within mutually agreed time frame, and to the entire satisfaction of TPCL, failing which TPCL will be at liberty to get it replaced/rectified at Bidder's risks and costs and recover all such expenses plus the TPCL's own charges (@ 20% of expenses incurred), from the Bidder or from 'Security cum Performance Deposit' as the case may be. <b>Free replacement:</b> Bidder shall further be responsible for 'free replacement' for another period of THREE years from the end of the guarantee period for any 'Latent Defects' if noticed and reported by TPCL.
<b>12.0</b>	<b>PACKAGING</b>	Bidder shall ensure that all the equipment covered under this specification shall be prepared for rail/road transport in a manner so as to protect the equipment from damage in transit. The material used for packing shall be environmentally friendly.
<b>13.0</b>	<b>TENDER SAMPLE</b>	1 sample of each size has to be submitted during technical evaluation of Tender
<b>14.0</b>	<b>TRAINING</b>	Not Applicable
<b>15.0</b>	<b>QUALITY CONTROL</b>	The bidder shall submit ' <b>Quality Assurance Plan</b> ' followed in respect of bought out Items manufactured by him a) Raw materials in process b) Final inspection c) Packaging d) Marking. As part of the plan, a schedule for stage and final inspection within the parameters of the delivery schedule shall be furnished. TPCL reserves the sole rights for the type test of random sample from the lot and in case of any discrepancy or deviation from the Type test certificates submitted along with the bid, the complete Lot shall be rejected. TPCL's nominated representative shall have free access to the bidder's works to carry out inspections.
<b>16.0</b>	<b>MINIMUM TESTING FACILITIES</b>	Bidder shall have adequate in house testing facilities for carrying out all routine and acceptance tests as per relevant International / Indian standards.
<b>17.0</b>	<b>MANUFACTU RING ACTIVITIES</b>	The successful bidder will have to submit (after placement of RC/ PO) technical compliance document and drawing of DO Fuse as per RC line items for getting approval before mass manufacturing. Manufacturing mass quantity to start only after getting CAT-

Rev No.	Description	Prepared By & Date	Checked By & Date	Approved for Issue By & Date
RO	Specification for 11KV DO Fuse unit	Suchismita Nayak	Niranjan Khuntia	Pourush Garg
		05/08/2020	05/08/2020	05/08/2020

<b>TP Central Odisha Distribution Limited</b>	 <b>TPCODL</b> <small>TP CENTRAL ODISHA DISTRIBUTION LIMITED</small>	<b>Specification for 11KV DO Fuse unit</b>
<b>NEG-SPEC-12</b>		<b>Date of Issue: 05/08/2020</b>

		A approved drawings or as per intimation from TPCL.						
<b>18.0</b>	<b>SPARES, ACCESSORIES AND TOOLS</b>	Not Applicable						
<b>19.0</b>	<b>DRAWINGS AND DOCUMENTS</b>	<p>Following documents shall be submitted along with the bid for approval after award of RC/PO:</p> <ul style="list-style-type: none"> <li>a) Completely filled-in clause wise compliance of the specification.</li> <li>b) General description of the equipment and all components including brochures</li> <li>c) Type test Certificates for each specified test</li> <li>d) Experience List.</li> <li>e) Cross sectional drawing of the DO Fuse.</li> <li>f) A detailed list of bought out items which got into the manufacture of DO Fuse should be furnished indicating the name of the firms from whom these items are procured.</li> </ul> <p>All the Documents and Drawings shall be in English Language.</p>						
<b>20.0</b>	<b>GUARANTEED TECHNICAL PARTICULARS</b>	Bidder to submit clause wise compliance.						
<b>21.0</b>	<b>SCHEDULE OF DEVIATIONS</b>	<p style="text-align: center;"><b><u>(TO BE ENCLOSED WITH TECHNICAL BID)</u></b></p> <p>All deviations from this specification shall be set out by the BiDOers, clause by Clause in this schedule. Unless specifically mentioned in this Schedule, the tender shall be deemed to confirm the purchaser's specifications.</p> <table border="1" style="width: 100%; border-collapse: collapse;"> <thead> <tr> <th style="width: 10%;">S.No.</th> <th style="width: 20%;">Clause No.</th> <th style="width: 70%;">Details of deviation with justifications</th> </tr> </thead> <tbody> <tr> <td style="height: 150px;"></td> <td></td> <td></td> </tr> </tbody> </table> <p>We confirm that there are no deviations apart from those detailed above.</p> <p style="text-align: center;">Seal of the Company <span style="float: right;">Signature :</span></p>	S.No.	Clause No.	Details of deviation with justifications			
S.No.	Clause No.	Details of deviation with justifications						

Rev No.	Description	Prepared By & Date	Checked By & Date	Approved for Issue By & Date
RO	Specification for 11KV DO Fuse unit	Suchismita Nayak	Niranjan Khuntia	Pourush Garg
		05/08/2020	05/08/2020	05/08/2020

<b>TP Central Odisha Distribution Limited</b>	 <b>TPCODL</b> <small>TP CENTRAL ODISHA DISTRIBUTION LIMITED</small>	<b>Specification for 11KV DO Fuse unit</b>
<b>NEG-SPEC-12</b>		<b>Date of Issue: 05/08/2020</b>

		Designation

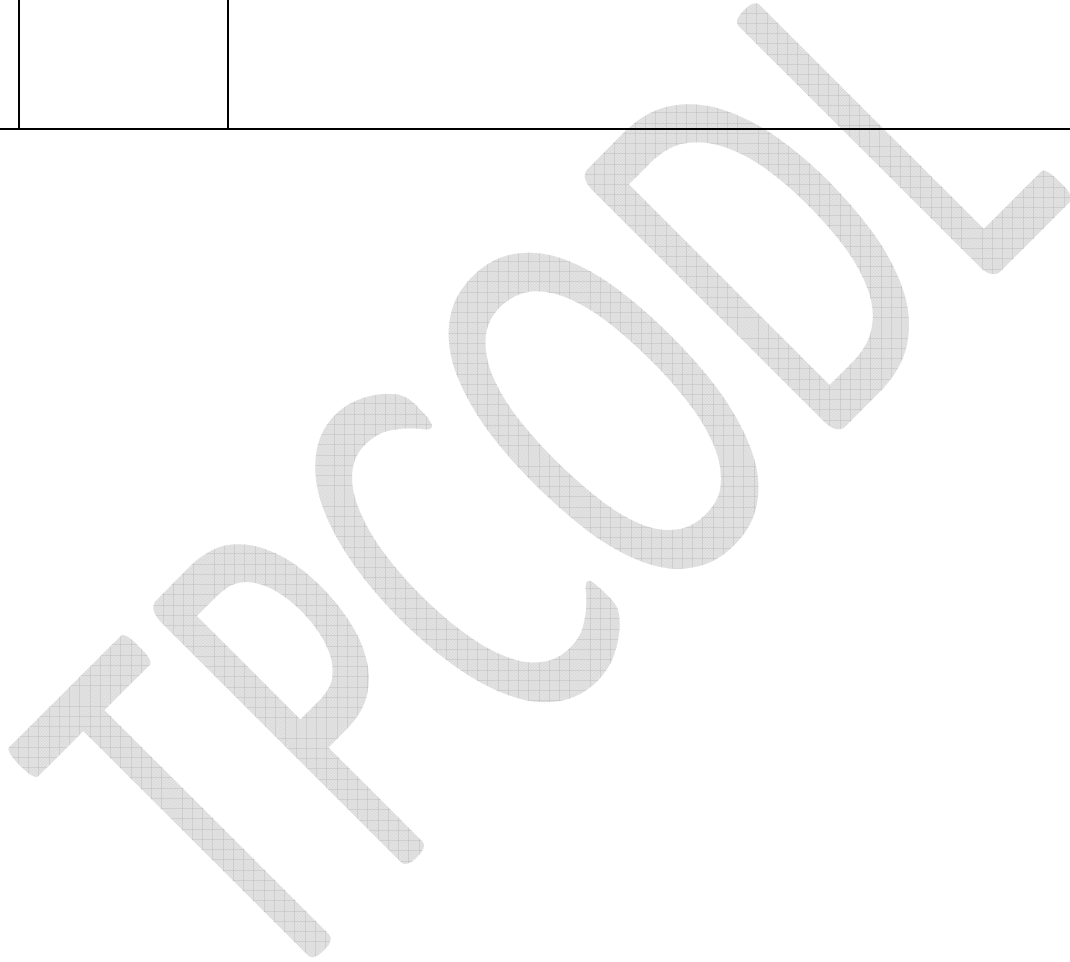

Rev No.	Description	Prepared By & Date	Checked By & Date	Approved for Issue By & Date
R0	Specification for 11KV DO Fuse unit	Suchismita Nayak	Niranjan Khuntia	Pourush Garg
		05/08/2020	05/08/2020	05/08/2020

<b>TP Central Odisha Distribution Limited</b>	 TP CENTRAL ODISHA DISTRIBUTION LIMITED	<b>Specification for 11KV DO Fuse unit</b>
<b>NEG-SPEC-12</b>		<b>Date of Issue: 05/08/2020</b>

ANNEXURE-1

**Inspection Test Plan**

S.no.	Acceptance Test	Reference standard
1	Dimension test	As per clause no. 4 of the technical specification ENG-XXX-XXXX
2	Time Current Characteristic	IS 9385-II, clause No. 7.6 & IEC 60282-1, Clause No. 6.7
3	Temperature-Rise Test	IS 9385-II, clause No. 7.4 & IEC 60282-1, Clause No. 6.5
4	Power frequency Voltage Withstand Test	IS 9385-II, clause No. 7.3.6 & IEC 60282-1, Clause No. 6.4.5
5	Tests of strikers	IEC 60282-1, Clause No. 6.8
6	Wet power frequency test	IEC 61109:2008

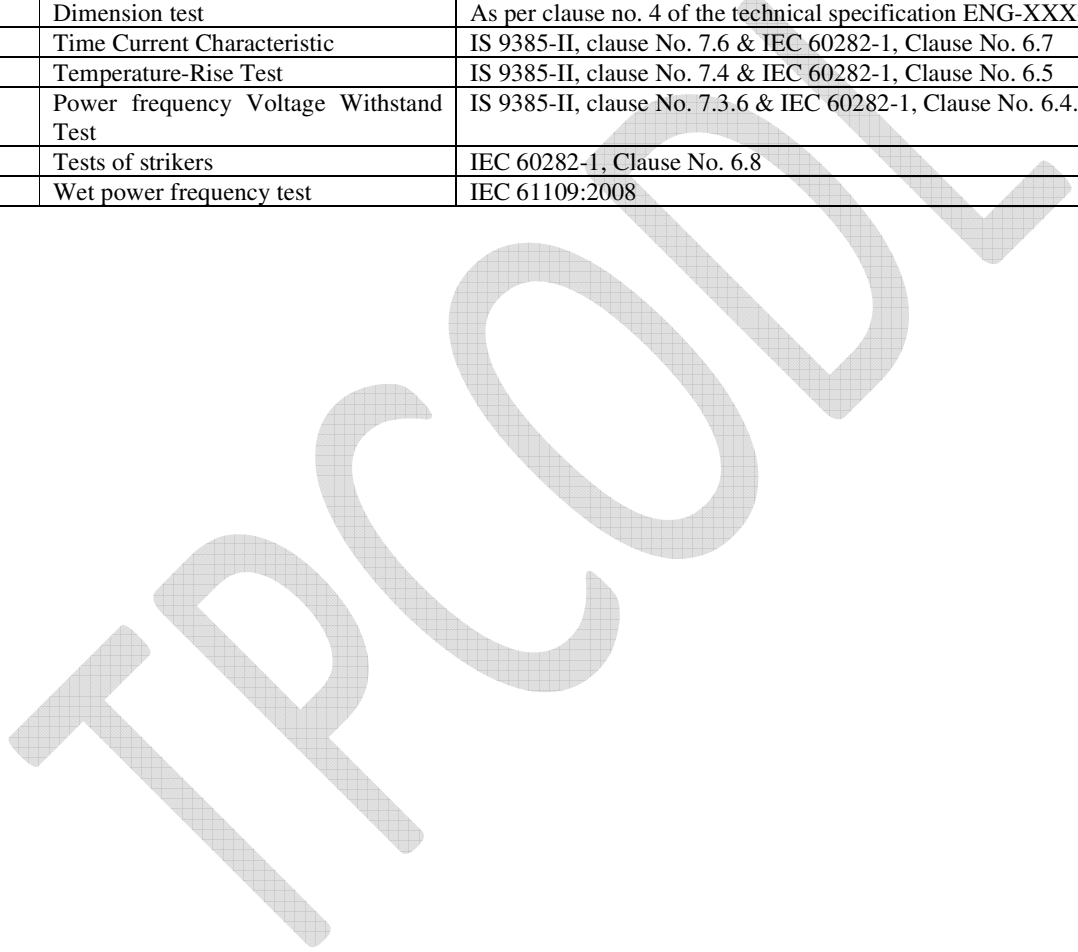

Rev No.	Description	Prepared By & Date	Checked By & Date	Approved for Issue By & Date
R0	Specification for 11KV DO Fuse unit	Suchismita Nayak	Niranjan Khuntia	Pourush Garg
		05/08/2020	05/08/2020	05/08/2020



TP Central Odisha Distribution Limited	 TP CENTRAL ODISHA DISTRIBUTION LIMITED	Specification for 11kV ,22kV and 33 kV UG Cable Joints and Terminations
NEG-SPEC-19		Date of Issue: 05/08/2020

**Technical Specification**  
**For**  
**Specification for 11kV ,22kV and 33 kV UG Cable Joints and**  
**Terminations**

**TP Central Odisha Distribution Limited.**  
**Network Engineering Group**  
**2<sup>nd</sup> Floor, IDCO Tower**  
**Janpath, Bhubaneswar- 751022**

Rev No.	Description	Prepared By & Date	Checked By & Date	Approved for Issue By & Date
R0	Specification for 11kV ,22kV and 33 kV UG Cable Joints and Terminations	Suchismita Nayak	Niranjan Khuntia	Pourush Garg
		05/08/2020	05/08/2020	05/08/2020



TP Central Odisha Distribution Limited	 TP CENTRAL ODISHA DISTRIBUTION LIMITED	Specification for 11kV ,22kV and 33 kV UG Cable Joints and Terminations
NEG-SPEC-19		Date of Issue: 05/08/2020

## CONTENTS

### # Special Instructions to Bidders

1. SCOPE
2. APPLICABLE STANDARDS
3. CLIMATIC CONDITIONS
4. GENERAL TECHNICAL REQUIREMENTS
5. TYPE TESTS
6. INSPECTION & TESTINGS
7. TENDER SAMPLE
8. GUARANTEE
9. PACKING OF KIT
10. DOCUMENTS
11. QUALITY ASSURANCE
12. DELIVERY
13. DEVIATIONS
14. GUARANTEED TECHNICAL PARTICULARS
15. SCHEDULE OF DEVIATION

Rev No.	Description	Prepared By & Date	Checked By & Date	Approved for Issue By & Date
R0	Specification for 11kV ,22kV and 33 kV UG Cable Joints and Terminations	Suchismita Nayak	Niranjan Khuntia	Pourush Garg
		05/08/2020	05/08/2020	05/08/2020

<b>TP Central Odisha Distribution Limited</b>		<b>Specification for 11kV ,22kV and 33 kV UG Cable Joints and Terminations</b>
<b>NEG-SPEC-19</b>	<b>TP CENTRAL ODISHA DISTRIBUTION LIMITED</b>	<b>Date of Issue: 05/08/2020</b>

**# Special Instructions for Bidders**

Please read the following instructions carefully before submitting your bid:

- 1) Commercial and Technical bids have to be submitted separately.
- 2) The bidder shall submit the Manufacturing Quality Plan along with the Technical Bid.
- 3) The bidder shall submit all the required Valid Type test reports and filled in Type test verification sheet supplied along with the Technical Bid .All the type test certificates will have to be verified and signed from Tata Power`s Consumer Engineering Department and signed Type test verification sheet will have to be submitted along with the Technical Bid. Technical bid will not be accepted in the absence of verified and signed Type test verification sheet.
- 4) The bidder shall submit the hard and soft (excel) format of the GTP`s during the technical bid submission. Instead of mentioning " refer or as per IS/IEC" exact value/s must be filled in.
- 5) Evaluation will be carried out on the content of technical bid only and no further correspondence will be made.
- 6) Any technical deviations shall be clearly mentioned only in deviation sheet.

Rev No.	Description	Prepared By & Date	Checked By & Date	Approved for Issue By & Date
R0	Specification for 11kV ,22kV and 33 kV UG Cable Joints and Terminations	Suchismita Nayak	Niranjan Khuntia	Pourush Garg
		05/08/2020	05/08/2020	05/08/2020

<b>TP Central Odisha Distribution Limited</b>		<b>Specification for 11kV ,22kV and 33 kV UG Cable Joints and Terminations</b>
<b>NEG-SPEC-19</b>	<b>TP CENTRAL ODISHA DISTRIBUTION LIMITED</b>	<b>Date of Issue: 05/08/2020</b>

## 1. SCOPE

This specification covers design, manufacture, testing, packing, inspection and delivery of cable terminations and joints employing Heat Shrink Technology suitable for 11 kV (E) ,22 kV (E) and 33 kV (E) Three core and Single core XLPE insulated screened and armoured cables as per IS 7098 part 2 with up to date amendments, having compacted circular stranded aluminium conductors of sizes 25 mm<sup>2</sup> to 1000 mm<sup>2</sup>.

It is not the intent to specify completely herein all details of design and construction of equipment/system .However equipment shall conform in all respects to high standards of Engineering, Design, and Workmanship and be capable of performing in continuous commercial operation up to vendors guarantee in a manner acceptable to the purchaser who will interpret the meaning of the drawings and specification and shall have the power to reject any work or materials, which in his judgement are not in full accordance therewith.

Bidder has to submit all relevant papers, copies of type test reports as required. Failure to do so may amount to the bids being considered non –responsive and outright rejection. The information as asked for is to be mentioned specifically and not be narrated like” as per ISS, relevant standard, reference to other pages of offer bid etc”.Technical data sheet annexed as Annexure –I has to be filled in completely and separately for indoor/outdoor terminations and straight through joints for each voltage class. Copies of the documents wherever asked for are to be enclosed for each requirement.

The offer documents have to be completely filled in and submitted even if there is repetition of information. The offer must have a clause wise affirmation of technical requirements.

Deviations /non-conformances/alternatives/.equivalents must be all separately listed as deviations.

Rev No.	Description	Prepared By & Date	Checked By & Date	Approved for Issue By & Date
R0	Specification for 11kV ,22kV and 33 kV UG Cable Joints and Terminations	Suchismita Nayak	Niranjana Khuntia	Pourush Garg
		05/08/2020	05/08/2020	05/08/2020

TP Central Odisha Distribution Limited	 TP CENTRAL ODISHA DISTRIBUTION LIMITED	Specification for 11kV ,22kV and 33 kV UG Cable Joints and Terminations
NEG-SPEC-19		Date of Issue: 05/08/2020

## 2. APPLICABLE STANDARDS

Applicable standards for testing of Heat Shrink joints and terminations along with material of the components:

IS -13573/2011	Joints & Terminations for polymeric cables for working voltages 6.6 kV up to and including 33 kV –Performance Requirements and Type Tests
ESI -09-13	Electricity Supply Industry Specification-Performance requirements on Heat shrinkable components
IEEE -48	Standard Test procedures and requirements for high voltage alternating current cable termination
IS -10810 :1984	Method of tests for cables

## 3. CLIMATIC CONDITIONS OF THE INSTALLATION

a	Average grade of Soil Condition	Water Logged
b	Ambient Air Temperature	Highest 45 deg C ,Average 35 deg C
c	Minimum	20 deg C
d	Relative Humidity	100 % Max
e	Thermal Resistivity of Soil	120 Deg C Cm/w
F	Seismic Zone	3
g	Rainfall	3000 mm concentrated in four
h	Maximum altitude above sea level	1000

## 4. GENERAL TECHNICAL REQUIREMENTS

**4.1. Class of Terminations:** The heat shrinkable terminations (Indoor and Outdoor type) offered shall be Class –I terminations as defined in IEEE standard 48.

**4.2. Class of Straight Through Joints:** The straight through joints must be suitable for direct burial with uncontrolled backfill, water logging, and open trays/trenches.

Rev No.	Description	Prepared By & Date	Checked By & Date	Approved for Issue By & Date
R0	Specification for 11kV ,22kV and 33 kV UG Cable Joints and Terminations	Suchismita Nayak	Niranjan Khuntia	Pourush Garg
		05/08/2020	05/08/2020	05/08/2020

<b>TP Central Odisha Distribution Limited</b>		<b>Specification for 11kV ,22kV and 33 kV UG Cable Joints and Terminations</b>
<b>NEG-SPEC-19</b>	<b>TP CENTRAL ODISHA DISTRIBUTION LIMITED</b>	<b>Date of Issue: 05/08/2020</b>

#### 4.3. Stress Control

4.3.1	The stress control function at the screen cut back shall be provided by a heat shrinkable tubing having volume resistivity of minimum 10 raise to 7 ohms-meter for both terminations and joints. Also, the relative permittivity shall be minimum 15. The length of stress control tubing should be minimum 130 mm for 11 kV and minimum 260 mm for 33 kV. Bidder shall furnish documentary evidence confirming adherence to these or the dimensions as per the type test report ,whichever is higher. Cross linking using irradiation only.
4.3.2	The impedance of stress control tubing shall not change over a range of temperature from 0 deg C to 125 deg C. Thermal Endurance test as per IEC 60216
4.3.3	For straight through joints prior to the installation of the stress control tubing ,high permittivity mastic must be applied over the connector ,overlapping the insulation by 3 mm .The minimum permittivity of the mastic shall be between 5 and 20
4.3.4	At the steps caused by semi conductive screen cut back, high permittivity mastic is to be provided to prevent discharge activity at the step. The minimum permittivity of the mastic should be 15. Semicconducting paints are not acceptable.
4.3.5	Silicone grease shall be provided for filling up the nicks and scratches on the surface of XLPE insulation.

#### 4.4. Non Tracking, Erosion and Weather Resistant Protection

4.4.1	The entire surface from the high voltage point to the earthing point of the cable shall be non-tracking, weather and erosion resistant, and hydrophobic in nature.
4.4.2	A heat shrinkable flexible polymeric tubing, coloured red, and possessing non tracking erosion and weather resistant properties shall be used as an external covering for the cable cores for both indoor and outdoor terminations. Rain sheds (skirts) wherever required for providing additional creepage shall also be of the same material as the non –tracking tube.

Rev No.	Description	Prepared By & Date	Checked By & Date	Approved for Issue By & Date
RO	Specification for 11kV ,22kV and 33 kV UG Cable Joints and Terminations	Suchismita Nayak	Niranjan Khuntia	Pourush Garg
		05/08/2020	05/08/2020	05/08/2020

<b>TP Central Odisha Distribution Limited</b>	<b>TPCODL</b> <small>TP CENTRAL ODISHA DISTRIBUTION LIMITED</small>	<b>Specification for 11kV ,22kV and 33 kV UG Cable Joints and Terminations</b>
<b>NEG-SPEC-19</b>		<b>Date of Issue: 05/08/2020</b>

4.4.3	The tubes must be extruded and expanded by irradiation process only
4.4.4	The tube material shall confirm to the requirements of ASTM-D-2303 and copies of the test report shall be furnished .Molded tubing are not acceptable.
4.4.5	The material used for manufacturing the non tracking tubing's and rain sheds (skirts) material confirm to Thermal Endurance Test as specified by IEC 60216 and shall be submitted in support of this assessment .Load cycling tests alone, shall not be considered sufficient basis for such life assessment.

#### **4.5 ENVIRONMENTAL SEALING**

4.5.1	Adhesives and sealants shall be provided in the termination and jointing kits for environmental sealing against ingress of moisture and aggressive gases. The adhesives and sealants will flow due to heating of heat shrinkable components or otherwise during installation and will fill all the voids and adhere to metal components and cable sheaths.
4.5.2	For terminations :The sealing of the strands between the lug barrel and cable termination shall be provided by: a)Non tracking, erosion and weather resistant non-tracking sealant coated over the inner side of heat shrinkable tubing b)Non tracking sealant strips The sealant should have unlimited shelf life.
4.5.3	For Joints: The outer black coloured heat shrinkable flexible polymeric tubing shall be pre-coated with adhesives to provide sealing of the exposed metallic components/earth connections. Irradiation to be used for cross-linking.
4.5.4	Provision of Additional Creepage for Indoor and Outdoor terminations-Single piece, heat shrinkable weather sheds (skirts) having non-tracking, erosion and weather resistant properties shall be supplied with the kits for providing additional creepage.The quantity of sheds to be supplied shall depend on voltage grade and Indoor/Outdoor application and shall be indicated along with the bid. Each shed shall give additional creepage length of at least 100 mm.

Rev No.	Description	Prepared By & Date	Checked By & Date	Approved for Issue By & Date
R0	Specification for 11kV ,22kV and 33 kV UG Cable Joints and Terminations	Suchismita Nayak	Niranjan Khuntia	Pourush Garg
		05/08/2020	05/08/2020	05/08/2020



<b>TP Central Odisha Distribution Limited</b>	 TP CENTRAL ODISHA DISTRIBUTION LIMITED	<b>Specification for 11kV ,22kV and 33 kV UG Cable Joints and Terminations</b>
<b>NEG-SPEC-19</b>		<b>Date of Issue: 05/08/2020</b>

#### .4.6 Insulation and Screen reinstatement for joints

4.6.1	To ensure a void free bond between the rebuilt insulation and non metallic screen the bidder shall supply single coextruded dual wall tubing which enables the final insulating layer to be installed complete with a conductive polymeric screen in one step. The dual walled tubing must be a coextruded and shall be offered with joints. Insulating sleeves coated with conductive material are not permitted. Bidders must confirm they are offering co-extruded dual wall tubing for straight through joints as indicated above.
4.6.2	Insulation Build up –Maximum three layers of insulation tubes shall be used. Total thickness of the insulation being provided in the joints shall not be less than 1.2 times the insulation of the cable being jointed. Physical and Electrical properties shall confirm to ESI 09:13

#### 4.7 Earth/Screen Continuity /Termination System

4.7.1	Metal screen continuity for each core shall be achieved by using tinned copper mesh and earth continuity by means of two tinned copper braided conductor of 25 sq mm for 11 kV and 35 sq mm for 22 and 33 kV. The armour bond shall be achieved by means of a combination of a steel support ring (for 3 core SWA cable) or Aluminium support ring (for 1 – core AWA cable) and two nos. of stainless steel hose clips. Support ring shall be `Zinc sprayed and central bulge/bump`.Width of the support ring shall be 70 mm.
4.7.2	In terminations, tinned copper braids of appropriate sizes along with copper lugs of appropriate sizes shall be provided for the continuity of screen/armour along with adequate holding arrangements.

Rev No.	Description	Prepared By & Date	Checked By & Date	Approved for Issue By & Date
R0	Specification for 11kV ,22kV and 33 kV UG Cable Joints and Terminations	Suchismita Nayak	Niranjan Khuntia	Pourush Garg
		05/08/2020	05/08/2020	05/08/2020

TP Central Odisha Distribution Limited		Specification for 11kV ,22kV and 33 kV UG Cable Joints and Terminations
NEG-SPEC-19	TP CENTRAL ODISHA DISTRIBUTION LIMITED	Date of Issue: 05/08/2020

#### 4.8 Lugs / Mechanical Connectors

4.8.1	The requisite number of long barrel Aluminium Lugs for terminations and Mechanical shear bolt type connectors for joints for compact circular stranded conductors shall be provided.
4.8.2	Mechanical shear bolt type connectors shall be in accordance with IEC 61238-1 and Class A. Connectors shall be of the water block type and the shear bolt heads shall be hexagonal. Bolts of the shear bolt type shall be suitable of adequate size. Lugs on aluminium cores shall be provided with oxidation

#### 4.9. Mechanical Protection

By means of a rollable steel mat (with required protective coating against corrosion)

#### 5. Type Tests

All products must be type tested in India at CPRI /ERDA as per the relevant IS (with latest amendments)/IEC .**The type tests certificates should not be more than 5 yrs. old.**

The bidder shall attach the drawing and instruction sheets duly approved by CPRI /ERDA which were used during type testing. All the copies of type certificates should be submitted along with the Technical Bid. The type tests to be carried out on each type of Jointing kit are as per the Type test verification sheet. Duly filled in and signed Type test verification sheet has to be submitted along with the Technical Bid. No follow up will be done for completing any incomplete Type test verification sheet and the bid will be rejected without any further communication.

No deviation to the type tested design shall be accepted. Any non-compliance observed at a later stage will invite blacklisting of the bidder with all the commercial implications.

Rev No.	Description	Prepared By & Date	Checked By & Date	Approved for Issue By & Date
R0	Specification for 11kV ,22kV and 33 kV UG Cable Joints and Terminations	Suchismita Nayak	Niranjan Khuntia	Pourush Garg
		05/08/2020	05/08/2020	05/08/2020



<b>TP Central Odisha Distribution Limited</b>	<b>TPCODL</b> <small>TP CENTRAL ODISHA DISTRIBUTION LIMITED</small>	<b>Specification for 11kV ,22kV and 33 kV UG Cable Joints and Terminations</b>
<b>NEG-SPEC-19</b>		<b>Date of Issue: 05/08/2020</b>

## 6. Testing and Inspection

6.1	All the routine and acceptance tests shall be carried out as per the ESI guidelines/relevant IS /IEEE.
6.2	Purchaser reserves the right to witness HV test shall be carried out on a randomly selected and installed Straight-Through Joint, in the presence of Purchaser representative, at manufacturer's works.
6.3	The joint shall withstand a test of 4 Uo voltage for 4 hours
6.4	Testing on all the moulded and heat shrinkable components, stress grading mastic etc. shall be done at the manufacturers works or third party test laboratories like ERDA/CPRI .This shall be part of Acceptance Test, in the presence of Purchasers representative.
6.5	i) Three sets of complete Test certificates (Routine and Acceptance) shall be submitted along with the delivery of Jointing kits. ii) Bought –out Items: Vendor shall submit Test certificates, lot/batch number-wise, from their sub-suppliers/principal.
6.6	Further tests mentioned below shall be conducted as acceptance tests at suppliers works or any approved test laboratory at suppliers work, which will be arranged by the supplier at his own cost: a) Visual Inspection-The kits under inspection should be free from any visible defects b) Physical verification of contents-All the contents shall be checked as per the kit contents list enclosed by the supplier c) Electric Strength test for insulation tubing's d) Elongation tests for all types of tubing e) Wall thickness ratio in expanded condition f) Longitudinal change after full recovery g) Tracking and erosion resistance test Test at S.no.(c),(d),(e),(f) and (g) shall be done on sample randomly selected from the lot.

Rev No.	Description	Prepared By & Date	Checked By & Date	Approved for Issue By & Date
R0	Specification for 11kV ,22kV and 33 kV UG Cable Joints and Terminations	Suchismita Nayak	Niranjan Khuntia	Pourush Garg
		05/08/2020	05/08/2020	05/08/2020

TP Central Odisha Distribution Limited	 TP CENTRAL ODISHA DISTRIBUTION LIMITED	Specification for 11kV ,22kV and 33 kV UG Cable Joints and Terminations
NEG-SPEC-19		Date of Issue: 05/08/2020

6.7	Supplier shall have a test facility fully equipped for conducting the routine tests, and acceptance test as per IS
-----	--

**7. Tender Sample**

Bidder shall have to submit the sample of material with the offer /as specified by Tata Power.

**8. Guarantee**

**The material shall be guaranteed for satisfactory performance for period of 60 months from the date of commissioning or 65 months from the date of receipt whichever is earlier against defective design, material and manufacturing.** In case of failure of any component of termination and joints, the bidder shall replace such defective terminations and kits free of cost within 3 months of such declaration and shall furnish an undertaking on non-judicial stamp along with the offer to bear the entire expenses which will be incurred by Tata Power towards material and labour in total for rectification/repairs.

**9. Packing of kit**

9.1	Every component /kit/box shall be properly sealed /packed for protection against damage. Stress grading mastic shall be packed in airtight /air sealed packing. Every kit box shall be wrapped in polythene covers. All components shall be sealed separately and marked clearly for the purpose of identification of each component.
-----	--

Rev No.	Description	Prepared By & Date	Checked By & Date	Approved for Issue By & Date
R0	Specification for 11kV ,22kV and 33 kV UG Cable Joints and Terminations	Suchismita Nayak	Niranjan Khuntia	Pourush Garg
		05/08/2020	05/08/2020	05/08/2020

<b>TP Central Odisha Distribution Limited</b>		<b>Specification for 11kV ,22kV and 33 kV UG Cable Joints and Terminations</b>
<b>NEG-SPEC-19</b>	<b>TP CENTRAL ODISHA DISTRIBUTION LIMITED</b>	<b>Date of Issue: 05/08/2020</b>

9.2	<p>Following Markings/Labels shall be on both sides of every packed box. 1)Identification number/type designation (as per manufacturer`s standard) 2)Voltage grade, size, description of the kit (including the voltage grade,size,type of cables for which it is to be used)</p> <p>3)Batch no., Lot no.,etc 4)Quantity</p> <p>5) a) Purchase Order no.&amp; date b) Purchaser`s name c) Tata Power Company`s SAP code number</p> <p>6)Weight (kg) of each Cable Termination kit and of each box containing kits</p> <p>7)Manufacturer`s name</p> <p>8)Month and Year of Manufacturing 9)Date of packing, shelf life</p>
9.3	<p>Besides above identification marking on packing, following identification marking shall be made on stress control tubes, dual wall tubes, outer jacketing tubes (in straight through joints),breakouts ,rain sheds, non tracking tubes:</p> <p>a)Batch No.to co-relate with the raw materials used to manufacture the components</p> <p>b)Shrink ratio</p> <p>c)Stress Control or Conductive as the case may be</p> <p>d)Manufacturer`s name</p> <p>“Property of Tata Power Company, Mumbai &amp; Material Code “shall be suitably embossed on these components.</p>

## 10. Documents

Documents” refer to documents, Data, Manuals, etc (Scanned copy of signed documents also shall be part of the entire soft file (e-file) or CD)

10.1	<p>Documents to be submitted along with the Bid- Vendor shall submit signed 2 sets (plus 1 set of soft copy) of following documents:</p> <p>a)GTP (duly filled in ) (as per Annexure- )</p> <p>b)Cross sectional drawings for components /Assembly</p> <p><b>c)Type Test Certificates</b></p> <p>d) Complete catalogue and installation instructions. e)Any other document</p>
------	--

Rev No.	Description	Prepared By & Date	Checked By & Date	Approved for Issue By & Date
R0	Specification for 11kV ,22kV and 33 kV UG Cable Joints and Terminations	Suchismita Nayak	Niranjan Khuntia	Pourush Garg
		05/08/2020	05/08/2020	05/08/2020

<b>TP Central Odisha Distribution Limited</b>		<b>Specification for 11kV ,22kV and 33 kV UG Cable Joints and Terminations</b>
<b>NEG-SPEC-19</b>	<b>TP CENTRAL ODISHA DISTRIBUTION LIMITED</b>	<b>Date of Issue: 05/08/2020</b>

10.2	Documents to be submitted After Award of contract- Vendor shall submit 2 sets (plus 1 set of soft copy) of above mentioned documents within 15 days for Purchasers approval.
------	---

## 11. QUALITY ASSURANCE (QA)

11.1	Vendor`s Quality Plan-To be submitted for Tata Power approval indicating the various stages of inspection ,the tests and checks that will be carried out on the material of construction ,components during manufacture and after finishing bought out items and fully assembled component during manufacture and after finishing ,bought out items and fully assembled component and equipment including drives. As a part of the plan, a schedule for stage and final inspection within the parameters of the delivery schedule shall be furnished. Tata Power representatives shall have free access to the manufacturer /sub supplier`s works to carry out inspections.
11.2	Inspection Hold Point to be mutually identified agreed and approved in quality plan.

The Jointing Kits would qualify only if they have been successful into service trails in the Tata Power Network / Network of reputed power distribution utilities as per the procedure. Documentary evidence to this effect need to be produced by the tender.

## 12. DELIVERY

The delivery of the jointing accessories will be on **Just in Time (JIT)** Model and mutually agreed SLA`s would be defined post award of OLA.

## 13. DEVIATIONS

Deviations from this specification can be acceptable, only where the vendor has listed the same in their bid the requirements that cannot be met and have been agreed to by Tata Power in writing before the OLA is placed. In the absence of any list of deviations from the bidder, it will be assumed by Tata Power that the bidder complies with the specifications fully

Rev No.	Description	Prepared By & Date	Checked By & Date	Approved for Issue By & Date
R0	Specification for 11kV ,22kV and 33 kV UG Cable Joints and Terminations	Suchismita Nayak	Niranjan Khuntia	Pourush Garg
		05/08/2020	05/08/2020	05/08/2020

<b>TP Central Odisha Distribution Limited</b>	 <b>TPCODL</b> <small>TP CENTRAL ODISHA DISTRIBUTION LIMITED</small>	<b>Specification for 11kV ,22kV and 33 kV UG Cable Joints and Terminations</b>
<b>NEG-SPEC-19</b>		<b>Date of Issue: 05/08/2020</b>

#### 14. GUARANTEED TECHNICAL PARTICULARS (GTP)

The bidder is deemed to have examined all the parts of the enquiry documents and to have been fully informed as to the nature of the work and the conditions related to its performance.

1	The bidder shall furnish all Technical details as called for in the following format for the specified voltage classes /sizes of heat shrinkable cable terminations/joints /components without which the offer shall be considered as incomplete and technically unresponsive. Specific details shall be furnished avoiding general statements like “as per standards “ etc	
2	Name of manufacturer	
3	Trade name of kits ,if any	
4	Enquiry Ref.	
5	Guarantee Period (minimum)	60 Months (from the date of commissioning) / 65 months (from date of receipt at Tata Power store) whichever is earlier.
6	Is the production in India supported by any collaboration?	
7	If so ,name and address of the principals	
8	Location and address of the manufacturers work in India, for indigenous components	
9	Applicable IS/IEC standard followed by vendor (incl.type test standard)	
10	Voltage Grade (kV)	
11	Type test reports not older than 5 yrs are enclosed? (Relevant test report no. and date, with type size, other details of each type of kit.)	Yes/No

Rev No.	Description	Prepared By & Date	Checked By & Date	Approved for Issue By & Date
R0	Specification for 11kV ,22kV and 33 kV UG Cable Joints and Terminations	Suchismita Nayak	Niranjan Khuntia	Pourush Garg
		05/08/2020	05/08/2020	05/08/2020

<b>TP Central Odisha Distribution Limited</b>	<b>TPCODL</b> <small>TP CENTRAL ODISHA DISTRIBUTION LIMITED</small>	<b>Specification for 11kV ,22kV and 33 kV UG Cable Joints and Terminations</b>
<b>NEG-SPEC-19</b>		<b>Date of Issue: 05/08/2020</b>

12	Whether all the heat shrinkable and moulded components of the kit meet the requirements of and have been tested in accordance with ESI-09-13 (for HS Joints)	Yes/No (If yes, details of test report no./Date/name of test laboratory to be mentioned)
13	Whether dimensional drawings indicating the clearance etc and bill of material for each kit is furnished along with the offer	Yes/No
14	Shelf life of Kits (years)	
15	Continuous operating temperature	90 deg C
16	a)Volume resistivity of the material of stress control tubing (Min) in ohm-mtr and length in mm b)Documentary evidence enclosed	
17	a)Relative permittivity (Min) of the material of stress control tubing b)Documentary evidence enclosed	
18	Thermal Endurance of Stress Control Tubings	
19	Minimum permittivity of stress grading mastic	
20	Volume resistivity of stress grading mastic	
21	Shelf life of non-tracking mastic	
22	Shelf life of stress grading mastic	

Rev No.	Description	Prepared By & Date	Checked By & Date	Approved for Issue By & Date
R0	Specification for 11kV ,22kV and 33 kV UG Cable Joints and Terminations	Suchismita Nayak	Niranjan Khuntia	Pourush Garg
		05/08/2020	05/08/2020	05/08/2020

<b>TP Central Odisha Distribution Limited</b>	 <b>TPCODL</b> <small>TP CENTRAL ODISHA DISTRIBUTION LIMITED</small>	<b>Specification for 11kV ,22kV and 33 kV UG Cable Joints and Terminations</b>
<b>NEG-SPEC-19</b>		<b>Date of Issue: 05/08/2020</b>

23	Whether co-extruded dual wall tubing is offered for joints	
24	Method of earth bond a)Size and no. of braids b)Size of armour support c)No. of hose clips	
25	Method of mechanical protection	
26	Method of protection against corrosion(type and coating thickness of corrosion protective layer on steel mat)	
27	Minimum Insulation thickness in joints 1)11 kV 2)22 kV 3)33 kV	1)----- mm 2)----- mm 3)----- mm
28	Number of layers required to achieve insulation build up 1)11 kV 2)22 kV 3)33 kV	1)----- 2)----- 3)-----
29	Total creepage for 1)11 kV Indoor terminations 2)11 kV Outdoor terminations 3)22 kV Indoor terminations 4)22 kV Outdoor terminations 5)33 kV Outdoor terminations	1)----- mm 2)----- mm 3)----- mm 4)----- mm 5)----- mm
30	Drawing of connector is enclosed	Yes/No
31	Installation procedure enclosed	Yes/No
32	Quality Assurance Programme (QAP for raw materials, in process inspection, factory testing) is enclosed	Yes/No

Rev No.	Description	Prepared By & Date	Checked By & Date	Approved for Issue By & Date
R0	Specification for 11kV ,22kV and 33 kV UG Cable Joints and Terminations	Suchismita Nayak	Niranjan Khuntia	Pourush Garg
		05/08/2020	05/08/2020	05/08/2020



<b>TP Central Odisha Distribution Limited</b>	 <b>TPCODL</b> TP CENTRAL ODISHA DISTRIBUTION LIMITED	<b>Specification for 11kV ,22kV and 33 kV UG Cable Joints and Terminations</b>
<b>NEG-SPEC-19</b>		<b>Date of Issue: 05/08/2020</b>

33	Printing details on each of the Heat Shrinkable and moulded components	(Mention the text, presently printed on each of the component)
34	Description of items in the kit that are imported /sourced from Principal /Sub-suppliers	
35	Name of the items in the kit and their respective shelf life (months/years)	
36	Packing of every kit	1 No
37	Group Packing	----- No. of kits per Box ----- No. of Boxes

#### 15. SCHEDULE OF DEVIATIONS ( TO BE ENCLOSED WITH THE BID )

All deviations from this specification shall be set out by the Bidders, clause by Clause in this schedule. Unless specifically mentioned in this Schedule, the tender shall be deemed to confirm the Purchaser's specifications:

S.No.	Clause No.	Details of deviation with justifications

We confirm that there are no deviations apart from those detailed above.

Seal of the Company:

Date :

Signature

Designation

Rev No.	Description	Prepared By & Date	Checked By & Date	Approved for Issue By & Date
R0	Specification for 11kV ,22kV and 33 kV UG Cable Joints and Terminations	Suchismita Nayak	Niranjana Khuntia	Pourush Garg
		05/08/2020	05/08/2020	05/08/2020



<b>TP Central Odisha Distribution Limited</b>	<b>TPCODL</b>  TP CENTRAL ODISHA DISTRIBUTION LIMITED	<b>Specification for 11kV,33KV cables</b>
<b>NEG-SPEC-17</b>		<b>Date of Issue: 05/08/2020</b>

**Technical Specification  
For  
Specification for 11kV & 33kV HT Cables**

**TP Central Odisha Distribution Limited.  
Network Engineering Group  
2<sup>nd</sup> Floor, IDCO Tower  
Janpath, Bhubaneswar- 751022**

Rev No.	Description	Prepared By & Date	Checked By & Date	Approved for Issue By & Date
R0	Specification for 11KV and 33kv cables	Anil Sah	Niranjan Khuntia	Pourush Garg
		05/08/2020	05/08/2020	05/08/2020

<b>TP Central Odisha Distribution Limited</b>	<b>TPCODL</b> <small>TP CENTRAL ODISHA DISTRIBUTION LIMITED</small>	<b>Specification for 11kV,33KV cables</b>
<b>NEG-SPEC-17</b>		<b>Date of Issue: 05/08/2020</b>

**CONTENTS**

- 1.0 SCOPE**
- 2.0 APPLICABLE STANDARDS**
- 3.0 CLIMATIC CONDITIONS OF THE INSTALLATION**
- 4.0 GENERAL TECHNICAL REQUIREMENTS**
- 5.0 GENERAL CONSTRUCTIONS**
- 6.0 NAME PLATE AND MARKING**
- 7.0 TESTS**
- 8.0 TYPE TEST CERIFICATES**
- 9.0 PRE-DISPATCH INSPECTION**
- 10.0 INSPECTION AFTER RECEIPT AT STORE**
- 11.0 GUARANTEE**
- 12.0 PACKING**
- 13.0 TENDER SAMPLE**
- 14.0 QUALITY CONTROL**
- 15.0 MINIMUM TESTING FACILITIES**
- 16.0 MANUFACTURING ACTIVITIES**
- 17.0 SPARES, ACCESSORIES AND TOOLS**
- 18.0 DRAWING AND DOCUMENTS**
- 19.0 GUARANTEED TECHNICAL PARTICULARS**
- 20.0 SCHEDULE OF DEVIATIONS**

<b>Rev No.</b>	<b>Description</b>	<b>Prepared By &amp; Date</b>	<b>Checked By &amp; Date</b>	<b>Approved for Issue By &amp; Date</b>
<b>RO</b>	<b>Specification for 11KV and 33kv cables</b>	<b>Anil Sah</b>	<b>Niranjan Khuntia</b>	<b>Pourush Garg</b>
		<b>05/08/2020</b>	<b>05/08/2020</b>	<b>05/08/2020</b>

<b>TP Central Odisha Distribution Limited</b>	 <b>TPCODL</b> TP CENTRAL ODISHA DISTRIBUTION LIMITED	<b>Specification for 11kV,33KV cables</b>
<b>NEG-SPEC-17</b>		<b>Date of Issue: 05/08/2020</b>

<b>1.0</b>	<b>SCOPE</b>	This specification covers technical requirements of design, manufacture, testing at manufacturer's works, packing, forwarding, supply and delivery at stores/site, performance of 11 and 33kV cable complete with all accessories for trouble free and efficient operations and conform to practices consistent with sound environmental management and local statutes.				
<b>2.0</b>	<b>APPLICABLE STANDARDS</b>	Cable covered under this specification shall unless otherwise stated, be designed, manufactured and tested in accordance with the latest editions of the following Indian, International standards / IEC and shall conform to the regulations of the local authorities.				
		IS 7098 (Part-2)-1985	Specification for Cross-linked polyethylene insulated PVC sheathed Cables Part: 2 - For working voltages from 3.3 kV up to and including 33 kV			
		IS 7098 (Part-3)	Voids and containments tests			
		IS 8130-1984	Specification for Conductor for insulated electric cables & flexible cords			
		IS 398(Part-IV)-1994	Aluminum conductors for overhead transmission purposes. Part 4 -Aluminum alloy stranded conductors.			
		IS 10418 – 1982	Specification for Drums for Electric cables			
		IS 5831-1984	Specification for PVC insulation and sheath of electric cables			
		IS: 3975 -1999	Mild steel wires, formed wires and tapes for armoring of cables.			
		IEC-60228: 2004	Conductor for insulated cables.			
		IEC-60502 (Part-2)	Power cables with extruded insulation and their accessories for rated voltages from 1 kV (Um = 1.2 kV) up to 30 kV (Um = 36 kV) - Part 2: 22 kV Cables for rated voltages from 6 kV (Um = 7.2 kV) up to 30 kV (Um= 36 kV).			
		IEC-60811: 1990	Test methods for insulations and sheaths of electric cables and cords.			
		IEC 60840: 2004	Power cables with extruded insulation and their accessories. Test methods and requirements.			
		ANSI/ICEA S-94 649:2004	Standard concentric neutral cables rated through 46kV			
		ASTM D 6097	Standard test method for relative resistance to vented water tree growth in Solid Dielectric insulating materials.			
		ASTM D 3137	Standard test method for Rubber property.			
		IS 10810	Methods of tests for cables			
<b>3.0</b>	<b>SYSTEM PARTICULARS AND CLIMATIC CONDITIONS OF THE INSTALLATION</b>	1.	Nominal System Voltage (kV)	11kV	22kV	33kV
		2.	Maximum System Voltage (kV)	12.1kV	24.2kV	36.5kV
		3.	Frequency (Hz)	50	50	50
		4.	Number of phases	3	3	3
		5.	System	Effectively grounded system		

Rev No.	Description	Prepared By & Date	Checked By & Date	Approved for Issue By & Date
RO	Specification for 11KV and 33kv cables	Anil Sah	Niranjan Khuntia	Pourush Garg
		05/08/2020	05/08/2020	05/08/2020

<b>TP Central Odisha Distribution Limited</b>	<b>TPCODL</b>  TP CENTRAL ODISHA DISTRIBUTION LIMITED	<b>Specification for 11kV,33KV cables</b>
<b>NEG-SPEC-17</b>		<b>Date of Issue: 05/08/2020</b>

6.	Grounding	Dyn11 with solidly grounded neutral.
	Fault level	Cables shall be suitable for withstanding without damage, the thermal and mechanical stresses due to a 3 phase symmetrical short circuit of:

33 kV Cable	
3CX400 sq.mm.	37.7 kA/sec
1CX630 sq.mm.	59.4 kA/sec
11 kV Cable	
3CX400 sq.mm.	37.7 kA/sec
3CX300 sq.mm.	28.3 kA/sec
1CX1000 sq.mm.	94.3 kA/sec
1CX630 sq.mm.	59.4 kA/sec
1CX185 sq.mm.	17.5 kA/sec

**Cable site installation ambient conditions:**

- a) Max. Ambient Temperature : 50 °C
- b) Max. Daily average ambient temp. : 40 °C
- c) Min Ambient Temperature : 0 °C
- d) Maximum Humidity : 100%
- e) Minimum Humidity : 10%
- f) Average No. of thunderstorm per annum : 50
- g) Average Annual Rainfall : 750 mm
- h) Average No. of rainy days per annum : 60
- i) Rainy months : June to Oct.
- j) Altitude above MSL not exceeding : 300meters.
- k) Wind Pressure : 126 kg/sq. m up an elevation of 10 m.

Atmosphere is generally laden with mild acid and dust suspended during dry months and subjected to fog in cold months. The design of the equipment and accessories shall be suitable to withstand seismic forces corresponding to an acceleration of 0.1g.

<b>4.0</b>	<b>GENERAL TECHNICAL REQUIREMENTS</b>	<b>S.No.</b>	<b>Description</b>	<b>Requirement</b>
		1.	Rated Voltage	12 kV(E) /24 kV (E)/36 kV(E)
		1.1	Operating Voltage	11 kV(E) /22 kV (E)/33 kV(E)
		2	Variation in supply voltage	+/- 10%
		3	Variation in Supply Frequency	+/- 5%
		4	Type of Cable	Water tight Aluminum conductor, XLPE Insulated, Extruded PVC Inner sheath, round GI wire armoured and PVC outer sheathed cable
		5	Core	Three/ Single
		6	Material of conductor	Stranded compacted circular Aluminum conductor as per IS:8130 – 1984
7	Conductor Screen	Extruded Semi-conducting compound		

Rev No.	Description	Prepared By & Date	Checked By & Date	Approved for Issue By & Date
RO	Specification for 11KV and 33kv cables	Anil Sah	Niranjan Khuntia	Pourush Garg
		05/08/2020	05/08/2020	05/08/2020

<b>TP Central Odisha Distribution Limited</b>	 <b>TPCODL</b> TP CENTRAL ODISHA DISTRIBUTION LIMITED	<b>Specification for 11kV,33KV cables</b>
<b>NEG-SPEC-17</b>		<b>Date of Issue: 05/08/2020</b>

		8	Insulation	XLPE insulation as per IS:7098 (Part-II)-1985
		9	Insulation Screen	a) Non-metallic: Extruded semiconducting compound b) Semiconducting compound water swellable tape c) Metallic: Copper tape
		10	Inner Sheath	Extruded PVC Compound Type ST2 as per IS:5831-1984
		11	Armour	a) Galvanized steel wire as per IS: 3975 – 1999 for multi core cable b) Round Al wire for single core cables c) RC tape as a binder over the armour
		12	Outer Sheath	Extruded PVC Compound Type ST2 as per IS: 5831-1984
5.0	<b>GENERAL CONSTRUCTION</b>	The cross linked polyethylene insulated (XLPE) cable (Dry cured) shall be manufactured and tested strictly as per IS 7098: Part-II with its latest amendments. The rating factors for variation in ground and air temperature, depth of laying, Thermal resistivity of soil and different laying configuration of cables shall be provided by the Bidder.		
5.1	<b>CONDUCTORS</b>	<p><b>5.1.1.</b> <b>Type:</b> All conductors shall be Class 2 stranded, compacted circular, plain Aluminium, Grade H4 as per IS 8130:1984. Conductor shall be of high electrical conductivity Aluminum as specified, conforming to requirement of relevant standards. Before stranding, the conductor shall be circular in cross-section, uniform in quality, solid, smooth and free from scale, sharp edges and other defects. <b>Water inhibition:</b> A conductor filling (strand blocking) shall be provided to inhibit water migration along the conductor. This material shall be water swellable non-conducting tape capable of 90 degree Celsius continuous operation. The filling material shall be compatible with semi conducting and insulating compounds in the cable. In addition, the filling material shall have zero flow and no drip at temperature below 90 degree Celsius and it shall not harm the electrical conductivity of the conductor or joint. The bidder shall describe the method of preparing the filled central conductor for jointing.</p> <p><b>5.1.2.</b> <b>Permissible number of joints:</b> Conductors shall conform to the standards for permissible number of joints in any one of the single wires forming every complete length of conductor, for location of joints in same layer of conductors and for method of making such joints. No joint shall be made in any conductor after it is stranded.</p>		
5.2	<b>CONDUCTOR SCREENING</b>	The conductor screening shall consist of a layer of extruded semi-conducting compound as per IS 7098- Part II, 1985 with latest amendments. The semi conducting compound shall be suitable for operating temperature of the cable and compatible with the insulating material. The semi-conducting screens should be effectively cross linked to achieve 90 °C cable rating. The interface between conductor screening and insulation shall be uniform and free from any protrusion/convolution on its surface.		
5.3	<b>INSULATION</b>	<p>5.3.1 The insulation material shall be Cross linked Polyethylene (XLPE) cured by Dry curing process and applied by extrusion process as per IS 7098:Part II with its latest amendments. The insulation properties shall be stable under thermal conditions arising out of continuous operation at conductor temperature of 90 deg. C rising momentarily to 250 deg. C under short circuit conditions.</p> <p>5.3.2 The average thickness of insulation shall be as per IS 7098(part II):1985 with latest amendments or as specified in GTP, whichever is greater with tolerance as per IS 7098 (Part-II):1985. It shall fit tightly to the conductor and shall be applied concentrically about the conductor in thickness consistent with voltage classification.</p> <p>5.3.3 The insulation shall be so applied that it shall be possible to remove it without damaging the conductor.</p>		

Rev No.	Description	Prepared By & Date	Checked By & Date	Approved for Issue By & Date
RO	Specification for 11KV and 33kv cables	Anil Sah	Niranjan Khuntia	Pourush Garg
		05/08/2020	05/08/2020	05/08/2020

<b>TP Central Odisha Distribution Limited</b>		<b>Specification for 11kV,33KV cables</b>
<b>NEG-SPEC-17</b>	<small>TP CENTRAL ODISHA DISTRIBUTION LIMITED</small>	<b>Date of Issue: 05/08/2020</b>

		5.3.4 The insulating material shall have excellent electrical properties with regard to resistivity, dielectric constant and loss factor and shall have high tensile strength and resistance to abrasion. This shall not deteriorate at high temperatures or when immersed in water. The insulation shall be preferably resistant to chemicals like acids, alkalies, & oils.
<b>5.4</b>	<b>INSULATION SCREENING</b>	<p>The insulation screening shall consist of following two parts:</p> <p>a) <b>Non-Metallic Part:</b> This shall be applied directly over the insulation of each core and shall consist of an extruded semi-conducting compound. The semi-conducting compound shall be suitable for the operating temperature of the cable and compatible with the insulating material. <b>For TPCODL:</b> Insulation screen shall be of strippable type with minimum thickness of 0.7mm.</p> <p>b) <b>Water Swellable tape:</b> The water swellable tape shall be applied over the non-metallic screening. This tape shall be of semiconducting compound acting as a moisture barrier for the core. The water swellable tape shall be applied over the semi conducting insulation screen of individual core with minimum <b>25% overlap</b> before the copper screening.</p> <p>c) <b>Metallic Part:</b> This shall consist of a layer of annealed copper tape and shall be applied over the water swellable tape. The copper screen over the water swellable tape shall be helically wound with minimum <b>20% overlap</b>.</p>
<b>5.5</b>	<b>CORE IDENTIFICATION</b>	For 3 Core Cable – Each of the three core shall be identified by applying the Red, Yellow and Blue coloured strips over them.
<b>5.6</b>	<b>LAYING UP OF CORES</b>	In three core cables, the cores shall be laid together with a suitable right hand lay. Where necessary, the interstices shall be filled with non-hygroscopic material.
<b>5.7</b>	<b>FILLERS</b>	In three core cables, fillers or bedding used in multi-conductor cables shall be non-wicking and non-moisture absorbing thermoplastic material. Fillers shall be so chosen as to be compatible with the temperature ratings of the cables and shall have no deleterious effect on any other component of the cable.
<b>5.8</b>	<b>INNER SHEATH</b>	<p><b>5.8.1</b> The laid up cores shall be provided with normal extruded inner sheath. It shall be ensured that the shape is as circular as possible. The inner sheath shall be of polyvinyl chloride (PVC) Compound conforming to the requirements of type ST-2 of IS: 5831-1984 with latest amendments. The inner sheath shall be black in colour.</p> <p><b>5.8.2</b> It shall be applied to fit closely on to the laid up cores and shall be possible to remove easily without causing any damage to the underlying insulated cores and screens.</p> <p><b>5.8.2</b> The minimum thickness of the inner sheath shall be as per IS: 7098 (Part-II) – 1985.</p>
<b>5.9</b>	<b>ARMOURING</b>	<p><b>5.9.1</b> The armoring shall be applied over the inner sheath in cables. The armoring shall be as follows:</p> <p>a) For Multicore cables: Galvanized round steel wires</p> <p>b) For Single Core Cables: H4 Grade aluminium wires</p> <p>It shall comply with the requirements of IS 3975:1999 along with latest amendments. The armor wires shall be applied as closely as possible. The direction of lay of the armor shall be left hand. The armour wires shall be applied as closely as practicable. The dimensions of armour round wires shall be as per IS-7098(Part-II): 1985.</p> <p><b>5.9.2</b> The rubberized cotton tape shall be applied to bind the armor wires such that it shall not affect the electrical properties of the armor wires and the overall cable.</p> <p><b>5.9.3</b> The joints in the armor wires shall be made by brazing or welding and the surface irregularities shall be removed. A joint in any wire shall be at least 300 mm from the nearest joint in any other armour wire in the completed cable.</p>
<b>5.10</b>	<b>OUTER SHEATH</b>	The outer sheath shall be applied by extrusion process. The outer sheath shall be of polyvinyl chloride (PVC) compound conforming to the requirements of type ST2 of IS 5831:1984 with latest amendments. The minimum and nominal thickness shall be as per IS 7098-(Part-II):1985 subject to tolerances as per

Rev No.	Description	Prepared By & Date	Checked By & Date	Approved for Issue By & Date
RO	Specification for 11KV and 33kv cables	Anil Sah	Niranjan Khuntia	Pourush Garg
		05/08/2020	05/08/2020	05/08/2020



TP Central Odisha Distribution Limited	 TP CENTRAL ODISHA DISTRIBUTION LIMITED	Specification for 11kV,33KV cables
NEG-SPEC-17		Date of Issue: 05/08/2020

		<p>standard. The PVC outer sheath shall be ultraviolet protected for operation in direct sunlight with extruded semi-conducting layer for performing the sheath integrity test.</p> <p>Colour coding of outer sheath shall be as mentioned below:</p> <table border="1"> <thead> <tr> <th>Cable Rating:</th> <th>TPCODL</th> </tr> </thead> <tbody> <tr> <td>11kV</td> <td>Yellow/ As specified by TPCODL</td> </tr> <tr> <td>33kV</td> <td>Black</td> </tr> </tbody> </table>	Cable Rating:	TPCODL	11kV	Yellow/ As specified by TPCODL	33kV	Black		
Cable Rating:	TPCODL									
11kV	Yellow/ As specified by TPCODL									
33kV	Black									
6.0	<b>MARKING</b>	<p>The <b>drum</b> shall carry the following information <b>stenciled</b> on both sides of the drum:</p> <ol style="list-style-type: none"> <li>Reference to the standards</li> <li>Manufacturer's name</li> <li>Type of Cable</li> <li>Voltage Grade</li> <li>Number of cores</li> <li>Nominal Cross sectional Area of the conductor/Cable size</li> <li>Cable Code</li> <li>Length of the cable on the drum</li> <li>Number of lengths on the drum (If more than one)</li> <li>Direction of the rotation of the drum</li> <li>Gross mass</li> <li>Country of manufacture</li> <li>Year and month of manufacture</li> <li>Purchase Order no.</li> </ol> <p>The following details shall be <b>embossed</b> on the <b>outer PVC Jacket</b> of the cable :</p> <ol style="list-style-type: none"> <li>Running meter marking</li> <li>"Property of TPCODL" at every meter – As per requirement of utility.</li> <li>"Name of Supplier" at every meter</li> <li>"Year of Manufacture" at every meter</li> <li>"Voltage grade" at every meter</li> <li>"Size of the cable" shall be embossed on the cable in bold letters.</li> <li>Font size of 12mm shall be used for all markings on single core cables and the embossing shall be done on one side throughout the length of cable for single core cables.</li> <li>Font size shall be as per below table for all markings on three core cables and the embossing shall be done on one side throughout the length of cable for three core cables.</li> </ol> <table border="1"> <thead> <tr> <th>Cable size, rating and code</th> <th>Font size</th> </tr> </thead> <tbody> <tr> <td>3C x 300 sq.mm 11 KV(E) A2XCEWY</td> <td>10 mm</td> </tr> <tr> <td>3C x 400 sq.mm 11 KV(E) A2XCEWY</td> <td>10 mm</td> </tr> <tr> <td>3C x 400 sq.mm 33 KV(E) A2XCEWY</td> <td>12 mm</td> </tr> </tbody> </table> <p>Voltage levels for all the cables shall be embossed legibly on the outer sheath of the cables.</p>	Cable size, rating and code	Font size	3C x 300 sq.mm 11 KV(E) A2XCEWY	10 mm	3C x 400 sq.mm 11 KV(E) A2XCEWY	10 mm	3C x 400 sq.mm 33 KV(E) A2XCEWY	12 mm
Cable size, rating and code	Font size									
3C x 300 sq.mm 11 KV(E) A2XCEWY	10 mm									
3C x 400 sq.mm 11 KV(E) A2XCEWY	10 mm									
3C x 400 sq.mm 33 KV(E) A2XCEWY	12 mm									
7.0	<b>TESTS</b>	<p>All routine, acceptance &amp; type tests shall be carried out in accordance with the relevant IS/IEC. All routine/acceptance tests shall be witnessed by TPCODL's authorized representative. All the components should also be type tested as per the relevant standards. Following tests shall be necessarily conducted on the 11/33kV cables in additions to others specified in IS/IEC standards.</p>								
7.1	<b>TYPE TEST</b>	<ol style="list-style-type: none"> <li>Tests on Conductor <ol style="list-style-type: none"> <li>Tensile stress</li> <li>Wrapping test</li> </ol> </li> </ol>								

Rev No.	Description	Prepared By & Date	Checked By & Date	Approved for Issue By & Date
RO	Specification for 11KV and 33kv cables	Anil Sah	Niranjan Khuntia	Pourush Garg
		05/08/2020	05/08/2020	05/08/2020

<b>TP Central Odisha Distribution Limited</b>	 <b>TPCODL</b> <small>TP CENTRAL ODISHA DISTRIBUTION LIMITED</small>	<b>Specification for 11kV,33KV cables</b>
<b>NEG-SPEC-17</b>		<b>Date of Issue: 05/08/2020</b>

		<ul style="list-style-type: none"> <li>c) Resistance test</li> <li>2) Tests for armoring wires as per IS 3975:1979</li> <li>3) Tests for thickness of insulation and sheath</li> <li>4) Physical test for insulation <ul style="list-style-type: none"> <li>a) Tensile strength and elongation at break as per IS 10810 (part 7)</li> <li>b) Ageing in air oven</li> <li>c) Hot test</li> <li>d) Shrinkage test</li> <li>e) Gravimetric test (Water absorption)</li> </ul> </li> <li>5) Physical test for outer sheath <ul style="list-style-type: none"> <li>a) Tensile strength and elongation at break as per IS 10810 (part 7)</li> <li>b) Ageing in air oven</li> <li>c) Shrinkage test</li> <li>d) Hot deformation</li> <li>e) Loss of mass in air oven</li> <li>f) Heat shock</li> <li>g) Thermal stability</li> </ul> </li> <li>6) Resistance to UV protection on outer sheath as per ASTM-G 154-16&amp;IS 10810 (part 7).</li> <li>7) Partial discharge test</li> <li>8) Bending test</li> <li>9) Dielectric power factor test <ul style="list-style-type: none"> <li>a) As a function of voltage</li> <li>b) As a function of temperature</li> </ul> </li> <li>10) Insulation resistance (volume resistivity) test</li> <li>11) Heating cycle test</li> <li>12) Impulse withstand test</li> <li>13) High voltage test</li> <li>14) Flammability test</li> <li>15) Water tightness test for water swellable tape</li> <li>16) Hydrophobic stability as per ASTM 3137-81</li> </ul>
7.2	<b>ACCEPTANCE TEST</b>	<ul style="list-style-type: none"> <li>1) Tensile stress</li> <li>2) Wrapping test</li> <li>3) Conductor resistance test</li> <li>4) Test for thickness of insulation and sheath</li> <li>5) Hot set test for insulation</li> <li>6) Tensile strength and elongation at break test for insulation and sheath.</li> <li>7) Partial discharge test</li> <li>8) High voltage test</li> <li>9) Insulation resistance (volume resistivity) test</li> </ul>
7.3	<b>ROUTINE TEST</b>	<ul style="list-style-type: none"> <li>1) Conductor Resistance test</li> <li>2) Partial Discharge test</li> <li>3) High Voltage test</li> </ul>
7.4	<b>ADDITIONAL TESTS</b>	<p>Additional tests for Concentricity, Voids, Contamination tests on insulation parameters as performed according to IS 7098 Part 3 to be performed to ensure that the cable should meet the following characteristics:</p> <ul style="list-style-type: none"> <li>• Core consistency with hot set/creep less than 100%</li> <li>• No voids larger than 75 microns per 16.4 cubic cm</li> <li>• No ambers larger than 250 microns per 16.4 cubic cm</li> <li>• No contaminants larger than 125 microns and less than 5 between 50-125 microns per cubic 16.4 cubic cm tested.</li> <li>• Cable insulation concentricity greater than 90% tested</li> </ul>

Rev No.	Description	Prepared By & Date	Checked By & Date	Approved for Issue By & Date
RO	Specification for 11KV and 33kv cables	Anil Sah	Niranjan Khuntia	Pourush Garg
		05/08/2020	05/08/2020	05/08/2020



TP Central Odisha Distribution Limited	 TP CENTRAL ODISHA DISTRIBUTION LIMITED	Specification for 11kV,33KV cables
NEG-SPEC-17		Date of Issue: 05/08/2020

		<ul style="list-style-type: none"> <li>No protrusions greater than 75 microns at the conductor shield and 125 microns at the insulation shield</li> </ul>
8.0	<b>TYPE TEST CERTIFICATES</b>	<p>The Bidder shall furnish the type test certificates of the 11 and 33 kV cable for the tests as mentioned above as per the corresponding standards. All the type tests shall be conducted at certified test laboratories like CPRI / ERDA / KEMA / NABL Accredited Lab as per the relevant standards. <b>Type test should have been conducted in certified Test Laboratories during the period not exceeding 5 years from the date of opening the bid.</b> In the event of any discrepancy in the test reports i.e. any test report not acceptable or any/all type tests (including additional type tests, if any) not carried out, same shall be carried out without any cost implication to TPCODL. Additional certification should be provided stating that :</p> <p>The cable produced is expected to meet long duration performance criteria based on quality and consistency of manufacturing.</p> <p>In case the type test certificates are dated beyond 5 years and up to 10 years maintaining basic component design same then deviation should be submitted on vendor letter head. TPCODL will have the rights to accept/reject the same.</p>
9.0	<b>PRE-DESPATCH INSPECTION</b>	<p>The Material shall be subject to inspection by a duly authorized representative of the TPCODL. Inspection may be made at any stage of manufacture at the discretion of TPCODL and the equipment, if found unsatisfactory as to workmanship or material, the same is liable to rejection. Bidder shall grant free access to the places of manufacture to TPCODL representatives at all times when the work is in progress. Inspection by TPCODL or its authorized representatives shall not relieve the bidder of his obligation of furnishing equipment in accordance with the specifications. The inspection of cable during manufacturing will be done especially while copper tape screening and forming of laid up cores for new vendors. Material shall be dispatched after specific MDCC (Material Dispatch Clearance Certificate) is issued by TPCODL</p> <p>Following documents shall be sent along with material</p> <ol style="list-style-type: none"> <li>Test reports</li> <li>MDCC issued by TPCODL</li> <li>Invoice in duplicate</li> <li>Packing list</li> <li>Drawings &amp; catalogue</li> <li>Guarantee / Warrantee card</li> <li>Delivery Challan</li> <li>Other Documents (as applicable).</li> </ol>
10.	<b>INSPECTION AFTER RECEIPT AT STORES</b>	<p>The material received at TPCODL store shall be inspected for acceptance and shall be liable for rejection, if found different from the reports of the pre-dispatch inspection and one copy of the report shall be sent to Contracts &amp; Engineering department.</p>
11.0	<b>GUARANTEE</b>	<p>Bidder shall stand guarantee towards design, materials, workmanship &amp; quality of process / manufacturing of items under this contract for due and intended performance of the same, as an integrated product delivered under this contract. In the event any defect is found by TPCODL, up to a period of at least 12 months from the date of commissioning or 24 months from the date of last supplies made under the contract whichever is later, (the time scale of 12/24 months could be enhanced subject to mutual agreements). Bidder shall be liable to undertake to replace/rectify such defects at its own costs, within mutually agreed time frame, and to the entire satisfaction of TPCODL, failing</p>

Rev No.	Description	Prepared By & Date	Checked By & Date	Approved for Issue By & Date
RO	Specification for 11KV and 33kv cables	Anil Sah	Niranjan Khuntia	Pourush Garg
		05/08/2020	05/08/2020	05/08/2020

<b>TP Central Odisha Distribution Limited</b>	 <b>TPCODL</b> <small>TP CENTRAL ODISHA DISTRIBUTION LIMITED</small>	<b>Specification for 11kV,33KV cables</b>
<b>NEG-SPEC-17</b>		<b>Date of Issue: 05/08/2020</b>

		<p>which TPCODL will be at liberty to get it replaced/rectified at Bidder's risks and costs and recover all such expenses plus the TPCODL own charges (@ 20% of expenses incurred), from the Bidder or from the "Security cum Performance Deposit" as the case may be.</p> <p>Bidder shall further be responsible for 'free replacement' for another period of THREE years from the end of the guarantee period for any 'Latent Defects' if noticed and reported by TPCODL.</p>
<b>12.0</b>	<b>PACKING</b>	<p>The cable shall be wound on strong weatherproof and non-returnable steel drums packed in coil lengths as specified below and in line with the requirement of IS 10418:1982 and its latest amendments. The ends of the cable shall be sealed by means of non-hygroscopic sealing material. Cable drums shall be so constructed as to have required mechanical strength so that the drum flanges and other components do not break during transport, in actual use or in storage. The flanges and the outside surface of the barrel shall be free from protruding materials or projections or unevenness capable of damaging the cable or hands of the operator during rotation of drums. A metal preservation shall be applied to the entire drum. All ferrous types used shall be treated with a suitable rust free finish or coating to avoid rusting during transit or storage. The drums shall withstand normal handling and transport</p> <p>The bidder shall ensure that all the equipment covered under this specification shall be prepared for rail/road transport in a manner so as to protect the equipment from damage in transit.</p> <p>Drum lengths for the 3 core cables should be as follows –  33 kV 3C x 400sq mm XLPE cable –250 m*  11 kV 3C x 300sq mm, 3C x 400 sq.mm. XLPE cable –250m*</p> <p><b>*Drums to accommodate cable lengths of min 150 m to max 500m shall be provided on request/as per purchase order.</b></p> <p>Drum lengths for the 1 core cables should be as follows –  33 kV 1C x 630sq mm XLPE cable –500 m  11 kV 1C x 185sq mm XLPE cable – 500 m  11 kV 1C x 630sq mm XLPE cable – 500 m  11 kV 1C x 1000sq mm XLPE cable – 500 m  Max drum length variation permitted is +/- 5%</p>
<b>13.0</b>	<b>TENDER SAMPLE</b>	Bidder shall have to submit the sample of material with the offer to TPCODL
<b>14.0</b>	<b>QUALITY CONTROL</b>	<p>The bidder shall submit with the offer Quality assurance plan indicating the various stages of inspection, the tests and checks which will be carried out on the material of construction, components during manufacture and bought out items and fully assembled component and equipment after finishing. As part of the plan, a schedule for stage and final inspection within the parameters of the delivery schedule shall be furnished.</p> <p>TPCODL reserves the sole rights for the type test of random sample from the lot and in case of any discrepancy or deviation from the Type test certificates submitted along with the bid, the complete Lot shall be rejected.</p> <p>TPCODL's engineer or its nominated representative shall have free access to the bidder's works to carry out inspections.</p>
<b>15.0</b>	<b>MINIMUM TESTING FACILITIES</b>	Bidder shall have adequate in house testing facilities for carrying out all routine and acceptance tests as per relevant International / Indian standards.
<b>16.0</b>	<b>MANUFACTURING ACTIVITIES</b>	The successful bidder will have to submit the bar chart for various manufacturing activities clearly elaborating each stage, with quantity. This bar chart should be in line with the Quality assurance plan submitted with the offer. This bar chart will have to be submitted within 15 days from the release of the order.
<b>17.0</b>	<b>SPARES, ACCESSORIES AND TOOLS</b>	Not Applicable

Rev No.	Description	Prepared By & Date	Checked By & Date	Approved for Issue By & Date
RO	Specification for 11KV and 33kv cables	Anil Sah	Niranjan Khuntia	Pourush Garg
		05/08/2020	05/08/2020	05/08/2020

<b>TP Central Odisha Distribution Limited</b>	<b>TPCODL</b>	<b>Specification for 11kV,33KV cables</b>
<b>NEG-SPEC-17</b>	TP CENTRAL ODISHA DISTRIBUTION LIMITED	<b>Date of Issue: 05/08/2020</b>

18.0	<b>DRAWINGS AND DOCUMENTS</b>	<p>Following documents shall be prepared based on the specifications and statutory requirements with complete BOM and shall be submitted with the bid:</p> <ol style="list-style-type: none"> <li>Completely filled-in Technical Parameters</li> <li>General description of the equipment and all components including brochures</li> <li>Type test Certificates</li> <li>Experience List.</li> <li>Cross sectional drawing of the cable.</li> </ol> <p>Drawings/Documents to be submitted after the award of the contract:</p> <table border="1"> <thead> <tr> <th>S. No</th> <th>Description</th> <th>For Approval</th> <th>For Review Information</th> <th>Final Submission</th> </tr> </thead> <tbody> <tr> <td>1</td> <td>Technical Parameters</td> <td>√</td> <td></td> <td>√</td> </tr> <tr> <td>2</td> <td>Manual/Catalogues/drawings for all components.</td> <td></td> <td>√</td> <td></td> </tr> <tr> <td>3</td> <td>Technical details and test certificates of XLPE compound.</td> <td></td> <td>√</td> <td>√</td> </tr> <tr> <td>4</td> <td>Cross sectional area of the cable</td> <td>√</td> <td></td> <td>√</td> </tr> <tr> <td>5</td> <td>Installation Instructions</td> <td></td> <td>√</td> <td>√</td> </tr> <tr> <td>6</td> <td>Instructions for use</td> <td></td> <td>√</td> <td>√</td> </tr> <tr> <td>7</td> <td>Transport/shipping dimension drawing</td> <td></td> <td>√</td> <td>√</td> </tr> <tr> <td>8</td> <td>QA &amp; QC Plan</td> <td>√</td> <td>√</td> <td>√</td> </tr> <tr> <td>9</td> <td>Routine, Acceptance and Type test Certificates</td> <td>√</td> <td>√</td> <td>√</td> </tr> <tr> <td>10</td> <td>Fault level calculation</td> <td>√</td> <td>√</td> <td>√</td> </tr> </tbody> </table> <p>All the Documents and Drawings shall be in English Language. After receipt of the order, the successful bidder will be required to furnish two copies of all relevant drawings/Documents for TPCODL approval.</p> <p><b>Instruction Manuals:</b> Bidder shall furnish manual (in English Language) covering erection and maintenance instructions and all relevant information pertaining to the cables in case supplying for the first time.</p>	S. No	Description	For Approval	For Review Information	Final Submission	1	Technical Parameters	√		√	2	Manual/Catalogues/drawings for all components.		√		3	Technical details and test certificates of XLPE compound.		√	√	4	Cross sectional area of the cable	√		√	5	Installation Instructions		√	√	6	Instructions for use		√	√	7	Transport/shipping dimension drawing		√	√	8	QA & QC Plan	√	√	√	9	Routine, Acceptance and Type test Certificates	√	√	√	10	Fault level calculation	√	√	√
		S. No	Description	For Approval	For Review Information	Final Submission																																																			
1	Technical Parameters	√		√																																																					
2	Manual/Catalogues/drawings for all components.		√																																																						
3	Technical details and test certificates of XLPE compound.		√	√																																																					
4	Cross sectional area of the cable	√		√																																																					
5	Installation Instructions		√	√																																																					
6	Instructions for use		√	√																																																					
7	Transport/shipping dimension drawing		√	√																																																					
8	QA & QC Plan	√	√	√																																																					
9	Routine, Acceptance and Type test Certificates	√	√	√																																																					
10	Fault level calculation	√	√	√																																																					

19.0	<b>GUARANTEED TECHNICAL PARTICULARS</b>	<table border="1"> <thead> <tr> <th>S. No.</th> <th>Particulars</th> <th>Units</th> <th>As required</th> <th>As furnished by Bidders</th> </tr> </thead> <tbody> <tr> <td>1</td> <td><b>Voltage Grade</b></td> <td>kV</td> <td>11/33 KV(E)</td> <td></td> </tr> <tr> <td>2</td> <td><b>Variation in Supply voltage</b></td> <td>%</td> <td>+/- 10</td> <td></td> </tr> <tr> <td>3</td> <td><b>Variation in Frequency</b></td> <td>%</td> <td>+/- 5</td> <td></td> </tr> <tr> <td>4</td> <td><b>Type of Cable</b></td> <td></td> <td>Stranded Aluminium Conductor, Screened, XLPE insulated, Extruded Semiconducting compound, water swellable tape, Copper tape, extruded PVC Inner Sheathed, GI Wire armoured bind by Rubberized cotton tape and PVC Outer Sheathed</td> <td></td> </tr> <tr> <td>5</td> <td><b>CONDUCTOR</b></td> <td></td> <td></td> <td></td> </tr> <tr> <td>a)</td> <td>Material</td> <td></td> <td>H4 grade Aluminium Conductor to IS:8130-1984</td> <td></td> </tr> </tbody> </table>	S. No.	Particulars	Units	As required	As furnished by Bidders	1	<b>Voltage Grade</b>	kV	11/33 KV(E)		2	<b>Variation in Supply voltage</b>	%	+/- 10		3	<b>Variation in Frequency</b>	%	+/- 5		4	<b>Type of Cable</b>		Stranded Aluminium Conductor, Screened, XLPE insulated, Extruded Semiconducting compound, water swellable tape, Copper tape, extruded PVC Inner Sheathed, GI Wire armoured bind by Rubberized cotton tape and PVC Outer Sheathed		5	<b>CONDUCTOR</b>				a)	Material		H4 grade Aluminium Conductor to IS:8130-1984	
		S. No.	Particulars	Units	As required	As furnished by Bidders																															
		1	<b>Voltage Grade</b>	kV	11/33 KV(E)																																
		2	<b>Variation in Supply voltage</b>	%	+/- 10																																
		3	<b>Variation in Frequency</b>	%	+/- 5																																
		4	<b>Type of Cable</b>		Stranded Aluminium Conductor, Screened, XLPE insulated, Extruded Semiconducting compound, water swellable tape, Copper tape, extruded PVC Inner Sheathed, GI Wire armoured bind by Rubberized cotton tape and PVC Outer Sheathed																																
		5	<b>CONDUCTOR</b>																																		
a)	Material		H4 grade Aluminium Conductor to IS:8130-1984																																		

Rev No.	Description	Prepared By & Date	Checked By & Date	Approved for Issue By & Date
RO	Specification for 11KV and 33kv cables	Anil Sah	Niranjan Khuntia	Pourush Garg
		05/08/2020	05/08/2020	05/08/2020

<b>TP Central Odisha Distribution Limited</b>	 <b>TPCODL</b> TP CENTRAL ODISHA DISTRIBUTION LIMITED	<b>Specification for 11kV,33KV cables</b>
<b>NEG-SPEC-17</b>		<b>Date of Issue: 05/08/2020</b>

	b)	No. of cores & size	Sq.mm	To be provided
	c)	Min. No. of wires	Nos.	To be furnished by Bidder
	d)	Shape of Conductor		Stranded Compacted Circular
	e)	Minimum Weight of Conductor	Kg/km/Core	To be furnished by Bidder
	6	<b>CONDUCTOR SCREEN</b>	mm	Extruded Semi Conducting Compound min. thickness - 0.3 mm (for three core cables) ; 0.5 mm (for single core cables)
	7	<b>INSULATION</b>		
	a)	Material		XLPE insulation as per IS: 7098 (Part-II) – 1985
	b)	Nom. Thickness	mm	11kV: 3CX300 sq.mm. – 3.6 mm 3CX400 sq.mm.- 3.6mm 1CX1000 sq.mm.- 3.6mm 1CX630 sq.mm.- 3.6mm 1CX185 sq.mm.- 3.6mm 33kV: 3CX400 sq.mm.- 8.8mm 1CX630 sq.mm.- 8.8mm
	8	<b>INSULATION SCREENING</b>		
	a)	Non Metallic Part		Ext. Semi Conducting Compound Layer (min. thickness 0.7 mm) – Strippable type.
	b)	Water swellable tape		Semi conducting compound with 25% overlap
	b)	Metallic Part	mm	Copper Tape (minimum thickness 0.045mm) with 20% overlap
	c)	Identification of cores		By using coloured strips as per Cl.13 of IS:7098(II)-1985
	9	<b>INNER SHEATH</b>		
	a)	Material		PVC Compound type ST-2 as per IS 5831-1984
	b)	Process of applying		Normal extruded and not pressure extruded
	c)	Min. Thickness	mm	0.7mm
	10	<b>ARMOURING</b>		
	a)	Material		For Multi-Core cable - Galvanized Steel Wire as per IS- 3975 : 1979 For Single core cable - H4 Grade aluminium wire
	b)	Nom. Thickness (GI) – For 3 Core cable	mm	33 kV ,3C x 400 Sq.mm. - 4 mm 11kV ,3C X 400 Sq. mm. – 4 mm 11 kV ,3C x 300 Sq. mm.- 3.15 mm
	c)	Nom. Thickness (Al) – For 1 Core cable	mm	33kV, 1C x 630 sq.mm. – 2.5mm 11 kV ,1C x 185 Sq.mm. -2.5 mm 11 kV ,1C x 630 Sq.mm. -2.0 mm 11kV, 1C x 1000 sq.mm. – 2.5mm
	c)	Rubberized cotton tape		RC tape to be provided to bind armour wires
	d)	Armouring Area Coverage		Minimum area of coverage shall be 90%. The gap between any two armour strip/wire shall not be more than the diameter of armour wire.

Rev No.	Description	Prepared By & Date	Checked By & Date	Approved for Issue By & Date
RO	Specification for 11KV and 33kv cables	Anil Sah	Niranjan Khuntia	Pourush Garg
		05/08/2020	05/08/2020	05/08/2020

<b>TP Central Odisha Distribution Limited</b>	 <b>TPCODL</b> TP CENTRAL ODISHA DISTRIBUTION LIMITED	<b>Specification for 11kV,33KV cables</b>
<b>NEG-SPEC-17</b>		<b>Date of Issue: 05/08/2020</b>

	11	<b>OUTER SHEATH</b>			
	a)	Material		Extruded PVC Compound Type ST2 as per IS: 5831-1984	
	b)	Minimum outer thickness	mm	33 kV ,3C x 400 Sq.mm. - 3 mm 33 kV ,1C x 630 Sq.mm. - 2.12 mm 11 kV ,3C x 400 Sq.mm. - 3 mm 11 kV ,3C x 300 Sq.mm. - 2.84 mm 11 kV ,1C x 185 Sq.mm. - 1.56 mm 11 kV ,1C x 630 Sq.mm. - 1.88 mm 11 kV ,1C x 1000 Sq.mm. - 2.2 mm	
	12	App. Calculated overall diameter	mm	To be furnished by Bidder	
	13	Tolerance on Diameter	mm	+/- 3	
	14	Standard Length with Tolerance	m	As specified in clause 12.0 of specification	
	15	Dimensions of the Drum:		To be furnished by Bidder	
	a)	With respect to Belly Diameter	mm	To be furnished by Bidder	
	b)	With respect to Overall Diameter of the cable	mm	To be furnished by Bidder	
	16	Equivalent effective Impedance of the Cable	Ohms/ Km	To be furnished by Bidder	
	17	Equivalent effective Capacitance of the cable	mF/Km	To be furnished by Bidder	
	18	Short circuit capacity of conductor for one sec.	kA/sec	33 kV Cable	
				3CX400 sq.mm.	37.7 kA/sec
				1CX630 sq.mm.	59.4 kA/sec
				11 kV Cable	
				3CX400 sq.mm.	37.7 kA/sec
				3CX300 sq.mm.	28.3 kA/sec
				1CX1000 sq.mm.	94.3 kA/sec
		1CX630 sq.mm.	59.4 kA/sec		
		1CX185 sq.mm.	17.5 kA/sec		
	19	Short time overload Capacity			
	20	For 1 hour	Amps.	To be furnished by Bidder	
	21	For 24 Hours	Amps.	To be furnished by Bidder	
	22	For 72 Amps.	Amps.	To be furnished by Bidder	
	23	Continuous current rating of cable when laid			
a)	Direct in ground at 35 Deg.C.	Amps.	To be furnished by Bidder		
b)	In Air at 45 Deg.C.	Amps.	To be furnished by Bidder		
c)	In Ducts	Amps.	To be furnished by Bidder		
d)	In 2 Circuits	Amps.	To be furnished by Bidder.		
e)	In 3 circuits	Amps.	To be furnished by Bidder		
24	Max. DC Resistance of Conductor at 20 Deg.C.	ohm/km	To be furnished by Bidder		
25	Approx. Weight of the Cable	Kg/m	To be furnished by Bidder		

Rev No.	Description	Prepared By & Date	Checked By & Date	Approved for Issue By & Date
RO	Specification for 11KV and 33kv cables	Anil Sah	Niranjan Khuntia	Pourush Garg
		05/08/2020	05/08/2020	05/08/2020

20.0	<b>SCHEDULE OF DEVIATIONS</b>	<b><u>(TO BE ENCLOSED WITH TECHNICAL BID)</u></b>			
		All deviations from this specification shall be set out by the Bidders, clause by Clause in this schedule. Unless specifically mentioned in this Schedule, the tender shall be deemed to confirm the purchaser's specifications.			
		S.No.	Clause No.	Details of deviation with justifications	
S.No.	Clause No.	Details of deviation with justifications			
We confirm that there are no deviations apart from those detailed above.					
Seal of the Company		Signature :			
		Designation			

Rev No.	Description	Prepared By & Date	Checked By & Date	Approved for Issue By & Date
RO	Specification for 11KV and 33kv cables	Anil Sah	Niranjan Khuntia	Pourush Garg
		05/08/2020	05/08/2020	05/08/2020



<b>TP Central Odisha Distribution Limited</b>	 <small>TP CENTRAL ODISHA DISTRIBUTION LIMITED</small>	<b>Specification for 11kV,33KV cables</b>
<b>NEG-SPEC-17</b>		<b>Date of Issue: 05/08/2020</b>



Rev No.	Description	Prepared By & Date	Checked By & Date	Approved for Issue By & Date
RO	Specification for 11KV and 33kv cables	Anil Sah	Niranjan Khuntia	Pourush Garg
		05/08/2020	05/08/2020	05/08/2020

<b>TP Central Odisha Distribution Limited</b>	 <small>TP CENTRAL ODISHA DISTRIBUTION LIMITED</small>	<b>Specification for AAAC</b>
<b>NEG-SPEC-18</b>		<b>Date of Issue: 05/08/2020</b>

**Technical Specification**  
**For**  
**Specification for All Aluminium Alloy Conductor (AAAC) for  
80sqmm and 100sqmm**

**TP Central Odisha Distribution Limited.**  
**Network Engineering Group**  
**2<sup>nd</sup> Floor, IDCO Tower**  
**Janpath, Bhubaneswar- 751022**

Rev No.	Description	Prepared By & Date	Checked By & Date	Approved for Issue By & Date
R0	Specification for AAAC	Anil Sah	Niranjan Khuntia	Pourush Garg
		05/08/2020	05/08/2020	05/08/2020



<b>TP Central Odisha Distribution Limited</b>	 <b>TPCODL</b> <small>TP CENTRAL ODISHA DISTRIBUTION LIMITED</small>	<b>Specification for AAAC</b>
<b>NEG-SPEC-18</b>		<b>Date of Issue: 05/08/2020</b>

**CONTENTS**

- 1.0 SCOPE**
- 2.0 STANDARDS**
- 3.0 GENERAL**
- 4.0 PHYSICAL CONSTANTS FOR ALUMINIUM ALLOY WIRES**
- 5.0 STANDARD SIZES**
- 6.0 JOINTS IN WIRES**
- 7.0 STRANDING**
- 8.0 LENGTHS AND VARIATIONS IN LENGTHS**
- 9.0 TESTS**
- 10.0 PACKING**
- 11.0 MARKING**
- 12.0 VERIFICATION CONDUCTOR LENGTH**
- 13.0 REJECTION AND RETESTS**

Rev No.	Description	Prepared By & Date	Checked By & Date	Approved for Issue By & Date
R0	Specification for AAAC	Anil Sah	Niranjan Khuntia	Pourush Garg
		05/08/2020	05/08/2020	05/08/2020

<b>TP Central Odisha Distribution Limited</b>	<b>TPCODL</b> <small>TP CENTRAL ODISHA DISTRIBUTION LIMITED</small>	<b>Specification for AAAC</b>
<b>NEG-SPEC-18</b>		<b>Date of Issue: 05/08/2020</b>

## 1. SCOPE

This specification covers design, Engineering, Manufacture, Testing, Inspection before dispatch, forwarding, packing, transportation to sites, Insurance (both during transit & storage), storage, erection, supervision testing & commissioning of all sizes of All Aluminum Alloy Conductors of the aluminum – magnesium- silicon type for use in the distribution overhead power lines of TPCODL of Odisha.

The equipment offered shall have been successfully type testes and the design shall have been satisfactory operation for a period not less than two years on the date of bid opening. Compliance shall be demonstrated by submitting with the bid,

(i) authenticated copies of the type test reports and (ii) performance certificates from the users.

The scope of supply includes the provision of type test, Rates of type tests shall be given in the appropriate price schedule of the bidding document and will be considered for evaluation. The Purchaser reserves the right to waive type tests as indicated in the section on Quality Assurance, Inspection and Testing in the specification.

The Aluminum Alloy Conductor shall conform in all respects to highest standards of engineering, design, workmanship, this specification and the latest revisions of relevant standards at the time of offer and the

Rev No.	Description	Prepared By & Date	Checked By & Date	Approved for Issue By & Date
R0	Specification for AAAC	Anil Sah	Niranjan Khuntia	Pourush Garg
		05/08/2020	05/08/2020	05/08/2020

<b>TP Central Odisha Distribution Limited</b>	<b>TPCODL</b>  TP CENTRAL ODISHA DISTRIBUTION LIMITED	<b>Specification for AAAC</b>
<b>NEG-SPEC-18</b>		<b>Date of Issue: 05/08/2020</b>

Purchaser shall have the power to reject any work or materials, which, in his judgment, is not in full accordance therewith.

## 2. STANDARDS

Except where modified by the specification, the Aluminum Alloy Conductor shall be designed, manufactured and tested in accordance with latest editions of the following standards.

IEC1089 - Round wire concentric lay overhead electrical standard conductors  
 IS 398- Aluminum Alloy Stranded Conductors  
 IS 9997- Aluminum Alloy redraw rods for electrical purposes  
 IEC 502 : 1994- Extruded solid dielectric insulated power cables for rated voltages 1.0 KV up to 30 KV  
 IEC 104- Aluminum Magnesium Silicon alloy wire for overhead line conductors  
 IS 1778- Reels and drums of bare conductor  
 BS : 6485- PVC covered conductors for overhead power lines.

This list is not to be considered exhaustive and reference to a particular standard or recommendation in this specification does not relieve the contractor of the necessity of providing the goods complying with other relevant standards or recommendations.

## 3. GENERAL

The wires shall be of heat treated aluminum, magnesium silicon alloy containing approximately silicon-0.5 to 0.9 %. magnesium-0.6 % to 0.9%, Fe-0.5% (maximum) , Copper- 0.1% (max ) , mn- 0.03% , Cr-0.03%, Zn-0.1%, B-0.06%, and having the mechanical and electrical

Rev No.	Description	Prepared By & Date	Checked By & Date	Approved for Issue By & Date
R0	Specification for AAAC	Anil Sah	Niranjan Khuntia	Pourush Garg
		05/08/2020	05/08/2020	05/08/2020

<b>TP Central Odisha Distribution Limited</b>	 TP CENTRAL ODISHA DISTRIBUTION LIMITED	<b>Specification for AAAC</b>
<b>NEG-SPEC-18</b>		<b>Date of Issue: 05/08/2020</b>

properties specified in the table and be smooth and free from all imperfections, such as, spills, splits and scratches.

Neutral grease shall be applied between the layers of wires. The drop point temperature of the grease shall not be less than 120<sup>0</sup> C

### 3.1 Mechanical and Electrical Characteristics of Aluminium Alloy Wires used in the Construction of Stranded Aluminium Alloy Conductors

Nominal Diameter	Minimum Diameter	Max. Diameter	Cross Sectional Area	Mass	Minimum Breaking Load		Maximum Resistance at 20 <sup>0</sup> C
					Before stranding	After stranding	
1	2	3	4	5	6	7	8
mm	Mm	mm	mm <sup>2</sup>	Kg/km	KN	KN	ohms/ km
3.15	3.12	3.18	7.793	21.04	2.37	2.29	4.290
3.81	3.77	3.85	11.40	30.78	3.52	3.34	2.938
3.94	3.90	3.98	12.19	32.92	3.77	3.58	2.746
4.26	4.22	4.30	14.25	38.48	4.40	4.18	2.345

Maximum resistance values given in column 8 have been calculated from the maximum values of the resistivity as specified and the cross sectional area based on the minimum diameter.

Rev No.	Description	Prepared By & Date	Checked By & Date	Approved for Issue By & Date
R0	Specification for AAAC	Anil Sah	Niranjan Khuntia	Pourush Garg
		05/08/2020	05/08/2020	05/08/2020

<b>TP Central Odisha Distribution Limited</b>	 TP CENTRAL ODISHA DISTRIBUTION LIMITED	<b>Specification for AAAC</b>
<b>NEG-SPEC-18</b>		<b>Date of Issue: 05/08/2020</b>

The minimum breaking load is calculated on nominal diameter at ultimate tensile strength of 0.309 KN / mm<sup>2</sup> for wire before stranding and 95% of the ultimate tensile strength after stranding.

#### 4. PHYSICAL CONSTANTS FOR ALUMINIUM ALLOY WIRES

##### 4.1 Resistivity :

For the purpose of this specification, the standard value of resistivity of aluminum alloy wire which shall be used for calculation is to be taken as 0.0325 ohm mm<sup>2</sup> /m at 20<sup>0</sup> C. the maximum value of resistivity of any single wire shall not , however, exceed 0.0328 ohm. mm<sup>2</sup>/m at 20<sup>0</sup> C . the maximum value of resistivity of any single wire shall not , however exceed 0.0328 ohm. mm<sup>2</sup>/m at 20<sup>0</sup> C

#### 5. TESTS

##### 5.1 Type Tests

The following tests shall be carried out as per relevant ISS once on samples of completed line conductor during each production run of up to 500 kms of the conductor from each manufacturing facility.

##### 5.1.1 Ultimate Tensile Strength Test

Rev No.	Description	Prepared By & Date	Checked By & Date	Approved for Issue By & Date
R0	Specification for AAAC	Anil Sah	Niranjan Khuntia	Pourush Garg
		05/08/2020	05/08/2020	05/08/2020

<b>TP Central Odisha Distribution Limited</b>	<b>TPCODL</b> <small>TP CENTRAL ODISHA DISTRIBUTION LIMITED</small>	<b>Specification for AAAC</b>
<b>NEG-SPEC-18</b>		<b>Date of Issue: 05/08/2020</b>

This test is intended to confirm not only the breaking strength of the finished conductor but also that the conductor has been uniformly stranded.

A conductor sample of minimum 5 m length fitted with compression dead end clamps at either end shall be mounted in a suitable tensile test machine. Circles perpendicular to the axis of the conductor shall be marked at two places on its surface. Tension on the conductor sample shall be increased at a steady rate upto 50% of the minimum UTS specified and held for one minute. The circles drawn shall not be distorted due to relative movement of the individual strands. Thereafter the load shall be increased at a steady rate to the specified minimum UTS and held at that load for one minute. The conductor sample shall not fail during this period. The applied load shall then be increased until the failing load is reached and the value recorded.

#### 5.1.2 D.C Resistance Test

On a conductor sample of minimum 5 m length two contact clamps shall be fitted with a pre-determined bolt torque. The resistance between the clamps shall be measured using a Kelvin double bridge by initially placing the clamps at zero separation and subsequently one meter apart. The test shall be repeated at least five times and the average value recorded. The value obtained shall be corrected to the value at 20<sup>0</sup> C, which shall conform to the requirements of this specification.

#### 5.2 Routine Tests

**Measurement of Physical Dimensions** : The samples should meet the desired dimensional requirements before conducting following Routine Tests as per relevant ISS.

Rev No.	Description	Prepared By & Date	Checked By & Date	Approved for Issue By & Date
R0	Specification for AAAC	Anil Sah	Niranjan Khuntia	Pourush Garg
		05/08/2020	05/08/2020	05/08/2020

<b>TP Central Odisha Distribution Limited</b>	 TP CENTRAL ODISHA DISTRIBUTION LIMITED	<b>Specification for AAAC</b>
<b>NEG-SPEC-18</b>		<b>Date of Issue: 05/08/2020</b>

### 5.2.1 Selection of Test Samples

Samples for the tests specified in this specification shall be taken by the manufacturer before stranding, from not less than 10% of the individual lengths of aluminium alloy wire included in any one final heat-treatment batch and which will be included in any one consignment of the stranded conductors to be supplied.

Alternatively, if desired by TPCODL at the time of placing an order, that the tests be made in the presence of his representative, samples of wire shall be taken from length of stranded conductor.

Samples shall then be obtained by cutting 1.2 meters from the outer end of the finished conductor from not more than 10% of the finished reels or drums.

Tests for electrical and mechanical properties of aluminum alloy wire shall ordinarily be made before stranding since wires unlaidd from conductors may have different physical properties from those of the wire prior to stranding because of the deformation brought about by stranding and by straightening for test.

Spools offered for inspection shall be divided into equal lots, the number of lots being equal to the number of samples to be selected, a fraction of a lot being counted as a complete lot. One sample spool shall be selected at random from each lot.

Rev No.	Description	Prepared By & Date	Checked By & Date	Approved for Issue By & Date
R0	Specification for AAAC	Anil Sah	Niranjan Khuntia	Pourush Garg
		05/08/2020	05/08/2020	05/08/2020



<b>TP Central Odisha Distribution Limited</b>	 TP CENTRAL ODISHA DISTRIBUTION LIMITED	<b>Specification for AAAC</b>
<b>NEG-SPEC-18</b>		<b>Date of Issue: 05/08/2020</b>

The following test shall be carried out once on samples of completed line conductor during each production run of up to 500 kms of the conductor from each manufacturing facility.

### 5.2.2 Breaking Load Test

The breaking load of one specimen, cut from each of the samples taken shall be determined by means of a suitable tensile testing machine. The load shall be applied gradually and the rate of separation of the jaws of the testing machine shall be not less than 25 mm / min and not greater than 100mm /min.

### 5.2.3 Elongation Test

The elongation of one specimen cut from each of the samples taken shall be determined as follows:

The specimen shall be straightened by hand and an original gauge length of 200 mm shall be marked on the wire. A tensile load shall be applied as described above and the elongation shall be measured after the fractured ends have been fitted together. If the fracture occurs outside the gauge marks, or within 25 mm of either mark, and the required elongation is not obtained, the test shall be disregarded and another test should be made.

When tested before and after stranding, the elongation shall not be less than 4% on a gauge length of 200 mm.

Rev No.	Description	Prepared By & Date	Checked By & Date	Approved for Issue By & Date
R0	Specification for AAAC	Anil Sah	Niranjan Khuntia	Pourush Garg
		05/08/2020	05/08/2020	05/08/2020



<b>TP Central Odisha Distribution Limited</b>	 TP CENTRAL ODISHA DISTRIBUTION LIMITED	<b>Specification for AAAC</b>
<b>NEG-SPEC-18</b>		<b>Date of Issue: 05/08/2020</b>

#### 5.2.4 D.C Resistance Test

The electrical resistance test of one specimen cut from each of the samples taken shall be measured at ambient temperature. The measured resistance shall be corrected to the value at 20<sup>0</sup> C by means of the formula :

$$R_{20} = R_T \frac{1}{\alpha + (T-20)}$$

where ,

R<sub>20</sub> = resistance corrected at 20<sup>0</sup> C  
R<sub>T</sub> = resistance measured T<sup>0</sup>C

α = constant – mass temperature coefficient of resistance, 0.0036, and T = ambient temperature during measurement.

The resistance corrected at 20<sup>0</sup> C shall not be more than the maximum values specified.

#### 5.2.5 Chemical Analysis of Aluminum Alloy

Samples taken from the alloy coils / strands shall be chemically / spectrographically analyzed. The results shall conform to the requirements stated in this specification. The contractor shall make available material

Rev No.	Description	Prepared By & Date	Checked By & Date	Approved for Issue By & Date
R0	Specification for AAAC	Anil Sah	Niranjan Khuntia	Pourush Garg
		05/08/2020	05/08/2020	05/08/2020

<b>TP Central Odisha Distribution Limited</b>	 TP CENTRAL ODISHA DISTRIBUTION LIMITED	<b>Specification for AAAC</b>
<b>NEG-SPEC-18</b>		<b>Date of Issue: 05/08/2020</b>

analyses, control documents and certificates from each batch as and when required by the **Purchaser**.

Test should be conducted at the independent test house by the purchaser in the case of absence

Of facility at manufacturer. However the cost of such testing shall be borne by the manufacturer.

### 5.2.6 Dimensional and Lay Length Check

The individual strands of the conductors shall be dimensionally checked and the lay lengths checked to ensure that they conform to the requirements of this specification.

Ten percent drums from each lot shall be rewound in the presence of the Purchaser or his representative to allow visual checking of the conductor for joints, scratches or other surface imperfections and to ensure that the conductor generally conforms to the requirements this specification. The length of conductor wound on the drum shall be re-measured by means of an approved counter / meter during the rewinding process.

### 5.2.7 Visual and dimensional Checks on the Conductor Drums.

The drums shall be visually and dimensionally checked to ensure that they conform to the requirements of this specification and of IS 1778: Specification for reels and drums of bare conductors. For wooden drums, a suitable barrel batten strength test procedure is required. The Bidder

Rev No.	Description	Prepared By & Date	Checked By & Date	Approved for Issue By & Date
R0	Specification for AAAC	Anil Sah	Niranjan Khuntia	Pourush Garg
		05/08/2020	05/08/2020	05/08/2020

<b>TP Central Odisha Distribution Limited</b>	 TP CENTRAL ODISHA DISTRIBUTION LIMITED	<b>Specification for AAAC</b>
<b>NEG-SPEC-18</b>		<b>Date of Issue: 05/08/2020</b>

shall state in his bid the tests to be carried out on the drums and shall include those tests in the Quality Assurance Programme.

**5.2.8 Acceptance Tests :**

All tests required to confirm enclosed Guaranteed Technical Particulars (GTP) requirements of this specification needs to be conducted as Acceptance Tests.

**9.3 Test Reports.**

- a) Copies of type test reports shall be furnished in at least six copies along with one original. One copy will be returned duly certified by the Owner only after which the commercial production of the material shall start.
- b) Record of routine test reports shall be maintained by the Supplier at his works for periodic inspection by the Owner's representative.
- c) Test certificate of tests during manufacture shall be maintained by the Contractor. These shall be produced for verification as and when desired by the Owner.

**6. Packing.**

- a) The conductor shall be supplied in returnable, strong, wooden drums provided with lagging of adequate strength, constructed to protect the conductor against any damage and displacement during transit, storage and subsequent handling and stringing operations in the field. The Contractor shall be responsible for any loss or damage during transportation handling and storage due to improper packing. The drums shall generally conform to IS: 1778-1980, except as otherwise specified hereinafter.

Rev No.	Description	Prepared By & Date	Checked By & Date	Approved for Issue By & Date
R0	Specification for AAAC	Anil Sah	Niranjan Khuntia	Pourush Garg
		05/08/2020	05/08/2020	05/08/2020

<b>TP Central Odisha Distribution Limited</b>	<b>TPCODL</b>  TP CENTRAL ODISHA DISTRIBUTION LIMITED	<b>Specification for AAAC</b>
<b>NEG-SPEC-18</b>		<b>Date of Issue: 05/08/2020</b>

- b) The drums shall be suitable for wheel mounting and for letting off the conductor under a minimum controlled tension of the order of 5 KN.
- c) The Contractor should submit their proposed drum drawings along with the bid.
- d) The Contractor may offer more than one length of the conductor in a single drum.
- e) All wooden components shall be manufactured out of seasoned soft wood free from defects that may materially weaken the component parts of the drums. Preservative treatment shall be applied to the entire drum with preservatives of a quality, which is not harmful to the conductor.
- f) The flanges shall be of two ply construction with a total thickness of 64 mm with each ply at right angles to the adjacent ply and nailed together. The nails shall be driven from the inside face flange, punched and then clenched on the outer face. Flange boards shall not be less than the nominal thickness by more than 2mm. There shall not be less than 2 nails per board in each circle. Where a slot is cut in the flange to receive the inner end of the conductor the entrance shall be in line with the periphery of the barrel.
- g) The wooden battens used for making the barrel of the conductor shall be of segmental type. These shall be nailed to the barrel supports with at least two nails. The batten shall be closely butted and shall provide a round barrel with smooth external surface. The edges of the battens shall be rounded or chamfered to avoid damage to the conductor.
- h) Barrel studs shall be used for the construction of drums. The flanges shall be holed and the barrel supports slotted to receive them. The barrel studs shall be treaded over a length on either end, sufficient to accommodate washers, spindle plates and nuts for fixing flanges at the required spacing.
- i) Normally, the nuts on the studs shall stand protruded of the flanges. All the nails used on the inner surface of the flanges and the drum barrel shall be counter sunk. The ends of barrel shall generally be flushed with the top of the nuts.
- j) The inner cheek of the flanges and drum barrel surface shall be painted with bitumen based paint.

Rev No.	Description	Prepared By & Date	Checked By & Date	Approved for Issue By & Date
RO	Specification for AAAC	Anil Sah	Niranjan Khuntia	Pourush Garg
		05/08/2020	05/08/2020	05/08/2020

<b>TP Central Odisha Distribution Limited</b>	<b>TPCODL</b> <small>TP CENTRAL ODISHA DISTRIBUTION LIMITED</small>	<b>Specification for AAAC</b>
<b>NEG-SPEC-18</b>		<b>Date of Issue: 05/08/2020</b>

- k) Before reeling, card board or double corrugated or thick bituminous water proof bamboo paper shall be secured to the drum barrel and inside of flanges of the drum by means of a suitable commercial adhesive material. The paper should be dried before use. After reeling the conductor, the exposed surface of the outer layer of conductor shall be wrapped with water proof thick bituminous bamboo paper to preserve the conductor from dirt, grit and damage during transport and handling.
- l) A minimum space of 75 mm for conductor shall be provided between the inner surface of the external protective lagging and outer layer of the conductor. Outside the protective lagging, there shall be minimum of two binders consisting of hoop iron/galvanized steel wire. Each protective lagging shall have two recesses to accommodate the binders.
- m) Each batten shall be securely nailed across grains as far as possible to the flange, edges with at least 2 nails per end. The length of the nails shall not be less than twice the thickness of the battens. The nails shall not protrude above the general surface and shall not have exposed sharp, edges or allow the battens to be released due to corrosion.
- n) The nuts on the barrel studs shall be tack welded on the one side in order to fully secure them. On the second end, a spring washer shall be used.
- o) A steel collar shall be used to secure all barrel studs. This collar shall be located between the washers and the steel drum and secured to the central steel plate by welding.
- p) Outside the protective lagging, there shall be minimum of two binders consisting of hoop iron/ galvanized steel wire. Each protective lagging shall have two recesses to accommodate the binders.
- q) The conductor ends shall be properly sealed and secured with the help of U-nail on the side of one of the flanges to avoid loosening of the conductor layers during transit and handling.
- r) As an alternative to wooden drum Contractor may also supply the conductors in

Rev No.	Description	Prepared By & Date	Checked By & Date	Approved for Issue By & Date
R0	Specification for AAAC	Anil Sah	Niranjan Khuntia	Pourush Garg
		05/08/2020	05/08/2020	05/08/2020

<b>TP Central Odisha Distribution Limited</b>	 TP CENTRAL ODISHA DISTRIBUTION LIMITED	<b>Specification for AAAC</b>
<b>NEG-SPEC-18</b>		<b>Date of Issue: 05/08/2020</b>

non- returnable painted steel drums. After preparation of steel surface according to IS: 9954, synthetic enamel paint shall be applied after application of one coat of primer. Wooden/Steel drum will be treated at par for evaluation purpose and accordingly the Contractor should quote in the package.

#### 11.0 Marking.

Each drum shall have the following information stenciled on it in indelible ink along with other essential data:

- (a) Contract/Award letter number
- (b) Name and address of consignee.
- (c) Manufacture's name and address.
- (d) Drum and lot number
- (e) Size and type of conductor
- (f) Length of conductor in meters
- (g) Arrow marking for unwinding
- (h) Position of the conductor ends
- (i) Number of turns in the outer most layer.
- (j) Gross weight of the drum after putting lagging.
- (k) Average weight of the drum without lagging.

Rev No.	Description	Prepared By & Date	Checked By & Date	Approved for Issue By & Date
R0	Specification for AAAC	Anil Sah	Niranjan Khuntia	Pourush Garg
		05/08/2020	05/08/2020	05/08/2020

<b>TP Central Odisha Distribution Limited</b>	 TP CENTRAL ODISHA DISTRIBUTION LIMITED	<b>Specification for AAAC</b>
<b>NEG-SPEC-18</b>		<b>Date of Issue: 05/08/2020</b>

- (l) Net weight of the conductor in the drum
  - (m) Month and year of manufacture of conductor The
- above should be indicated in the packing list also

**12. Verification Conductor length**

The Owner reserves the right to verify the length of conductor after unreeling at least five (5) percent of the drums in a lot offered for inspection. For the balance drums, length verification shall be done by the owner based on report/certification from Manufacturer/ Contractor.

**13. REJECTION AND RETESTS**

**13.1 Type Tests**

Should the conductor fail any of the type tests specified above, the Purchaser will not accept any conductor manufactured from the material, nor conductor made by the manufacturing methods used for the conductor which failed the test.

The manufacturer shall propose suitable modifications to his materials and techniques in order that he can produce conductor which will satisfactorily pass the type test requirements.

**13.2 Routine Tests**

Should any one of the test pieces first selected fail the requirements of the tests, two further samples from the same batch shall be selected for testings,

Rev No.	Description	Prepared By & Date	Checked By & Date	Approved for Issue By & Date
R0	Specification for AAAC	Anil Sah	Niranjan Khuntia	Pourush Garg
		05/08/2020	05/08/2020	05/08/2020



<b>TP Central Odisha Distribution Limited</b>	 TP CENTRAL ODISHA DISTRIBUTION LIMITED	<b>Specification for AAAC</b>
<b>NEG-SPEC-18</b>		<b>Date of Issue: 05/08/2020</b>

one of which shall be from the length from which the original test sample was taken

unless that length has been withdrawn by the manufacturer.

Should the test pieces from both these additional samples satisfy the requirements of the tests, the batch represented by these samples shall be deemed to comply with the standard. Should the test pieces from either of the two additional samples fail, the batch represented shall be deemed not to comply with the standard.

If checks on individual strand diameters, conductor lay lengths and conductor surface condition indicate non-compliance with the requirements of the specification, the particular drum will be rejected. Inspection will then be carried out on two further drums within the same batch. If the conductor on either of the drums is non-complaint, the complete batch will be rejected.

**GTP FOR ALL ALUMINIUM ALLOY CONDUCTOR**

Sl. No.	Particulars	Specified Requirement	Details furnished by the bidder size wise
------------	-------------	--------------------------	--

Rev No.	Description	Prepared By & Date	Checked By & Date	Approved for Issue By & Date
R0	Specification for AAAC	Anil Sah 05/08/2020	Niranjan Khuntia 05/08/2020	Pourush Garg 05/08/2020



<b>TP Central Odisha Distribution Limited</b>	 <b>TPCODL</b> <small>TP CENTRAL ODISHA DISTRIBUTION LIMITED</small>	<b>Specification for AAAC</b>
<b>NEG-SPEC-18</b>		<b>Date of Issue: 05/08/2020</b>

1.	Nominal Aluminium Alloy area of conductor in Sq.mm	:	<b>80</b>	<b>100</b>	
2.	No. of stands	:	7	7	
3.	Wire dia. in mm				
	a) Nominal	:	3.81	4.26	
	b) Minimum	:	3.77	4.22	
	c) Maximum	:	3.85	4.3	
4.	Approximate Over all diameter of conductor in mm	:	11.43	12.78	
5.	Cross sectional area in Sq.mm				
	i) Individual wire	:	11.4	14.25	
	ii) Standard Conductor	:	80	99.81	
6.	Minimum breaking load in KN				
	i) Individual wire	:	3.34	4.18	
	ii) Standard Conductor (U.T.S)	:	23.41	29.26	
7.	Approximate mass in Kg. Per KM of Aluminium Alloy conductor				
	i) Individual wire	:	30.78	38.48	
	ii) Standard Conductor	:	218.26	272.86	
8.	Calculated maximum DC resistance at 20 <sup>0</sup> C in Ohm/Km				

Rev No.	Description	Prepared By & Date	Checked By & Date	Approved for Issue By & Date
R0	Specification for AAAC	Anil Sah	Niranjan Khuntia	Pourush Garg
		05/08/2020	05/08/2020	05/08/2020

<b>TP Central Odisha Distribution Limited</b>	 TP CENTRAL ODISHA DISTRIBUTION LIMITED	<b>Specification for AAAC</b>
<b>NEG-SPEC-18</b>		<b>Date of Issue: 05/08/2020</b>

	i) Individual wire	:	2.938	2.345	
	ii) Standard Conductor	:	0.425	0.339	
13.	Modulus of Elasticity of Aluminium Alloy conductor Kg/Sq.mm	:	0.6324X10 <sup>6</sup>		
16.	Co-efficient of linear expansion per degree centigrade for	:			
	a) Individual °C	:	23X10 <sup>6</sup>		

Rev No.	Description	Prepared By & Date	Checked By & Date	Approved for Issue By & Date
R0	Specification for AAAC	Anil Sah	Niranjana Khuntia	Pourush Garg
		05/08/2020	05/08/2020	05/08/2020

<b>TP Central Odisha Distribution Limited</b>	 <small>TP CENTRAL ODISHA DISTRIBUTION LIMITED</small>	<b>Specification for AAAC</b>
<b>NEG-SPEC-18</b>		<b>Date of Issue: 05/08/2020</b>



Rev No.	Description	Prepared By & Date	Checked By & Date	Approved for Issue By & Date
R0	Specification for AAAC	Anil Sah	Niranjan Khuntia	Pourush Garg
		05/08/2020	05/08/2020	05/08/2020

## **List of Drawing Hoisting in CESU's WEBSITE**

<b>Sl. No.</b>	<b>Particulars</b>	<b>No. of Pages</b>
1	4 bolted tension clamp	1
2	8 Mtr PSC Pole for LT Lines Model	1
3	10 Mtr PSC Pole 330KG.	1
4	10 Mtr PSC Pole 400KG.	1
5	11 KV V-Cross Arm For PSC Joist	1
6	11 KV V-Cross Arm For RS Joist	1
7	11 KV CT STR	1
8	11 KV SI STR	1
9	33 KV V-Cross Arm For PSC Joist	1
10	33 KV V-Cross Arm For RS Joist	1
11	33 KV CT STR	1
12	33 LA STR	1
13	33 KV PT STR	1
14	33 KV SI STR	1
15	200 KVA DT PLINTH	1
16	Arrangement of Spike	1
17	G1, G2, G3 BEAM	1
18	G2X, G2AX BEAM	1
19	G5B, G6A, G6B BEAM	1
20	G7A, G7B BEAM	1
21	R1 , R1X ,G5A BEAM	1
22	CABLE TRENCH ELEVATION & PLAN	4
23	CGL MAKE VCB FOUNDATION	1
24	DP Structure	3
25	DP Structure for DT	8
26	Earth mat laying	1
27	Earthing device for line & sub stn	2
28	Elevation 33 kV Sub Station	4
	FOUNDATION BOLT (INDOOR & OUTDOOR)	2
29	Indoor & Outdoor	2
30	PG Clamp	1
31	Schneider make 33 KV VCB	2
32	Schematic drawing	1
33	T clamp	1
34	T Column Str & Plan	6
35	Trans. Foundation	1
	<b>Total Nos. Of Sheet</b>	<b>60</b>

# 4 BOLTED TENSION CLAMP

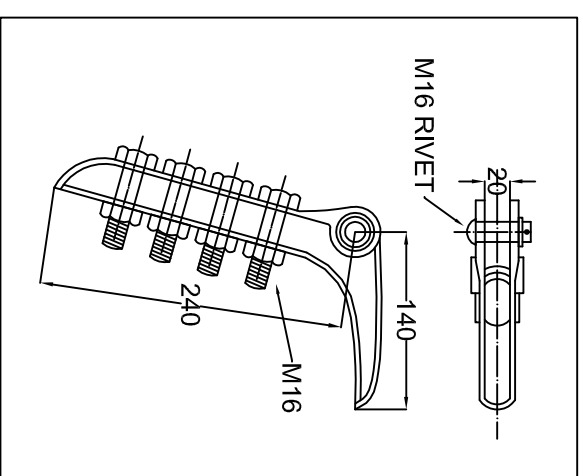
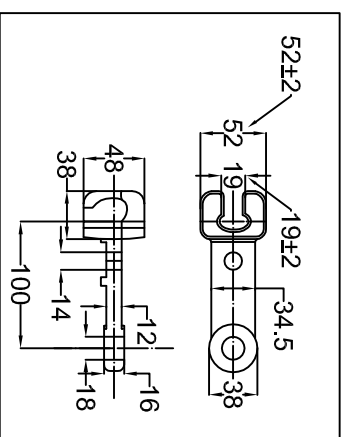
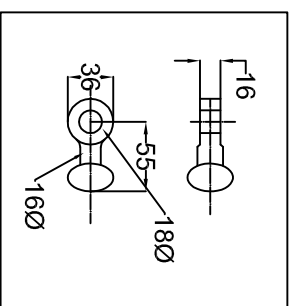
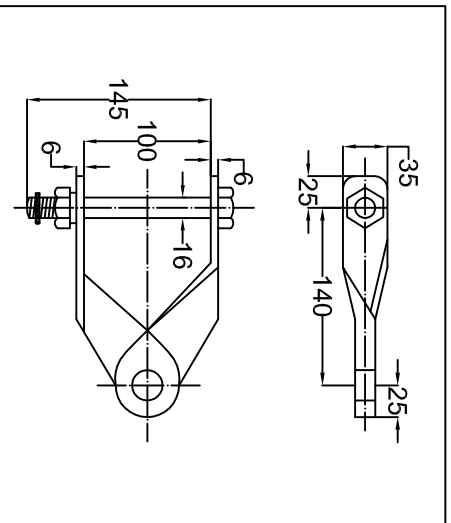
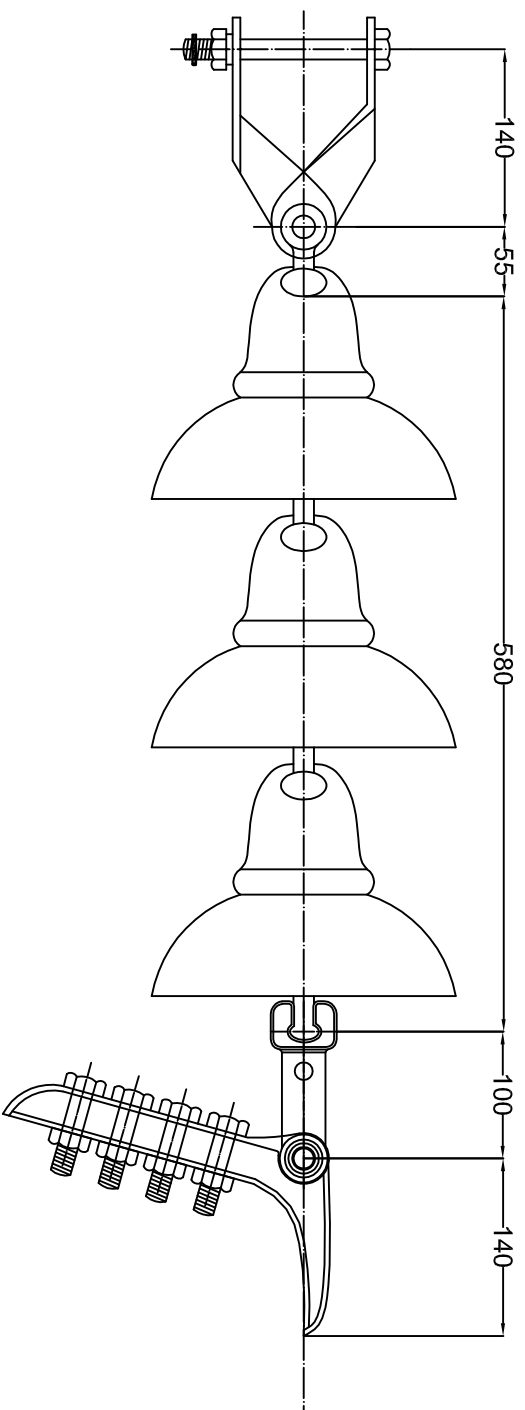

# 8.0 MTR/200Kg PSC POLE

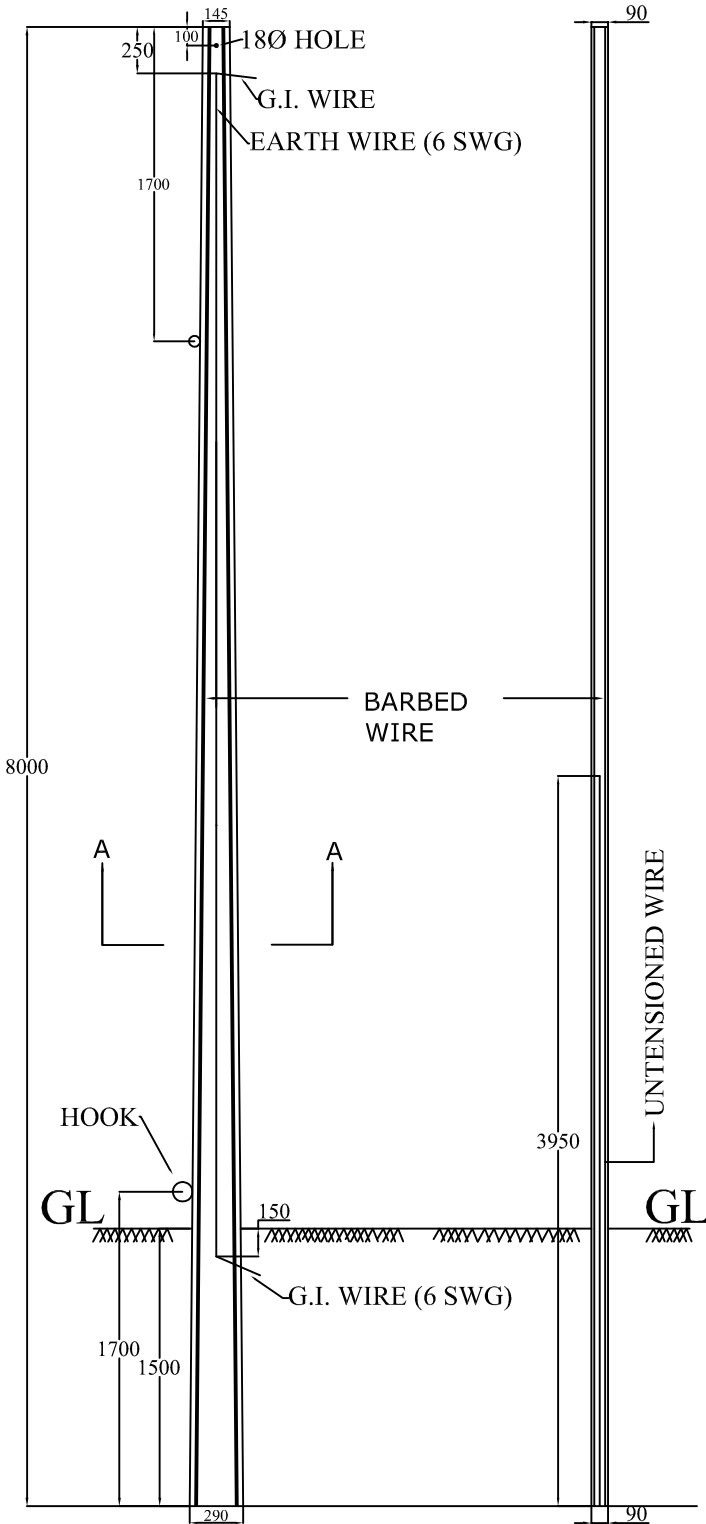

ELEVATION

SIDE

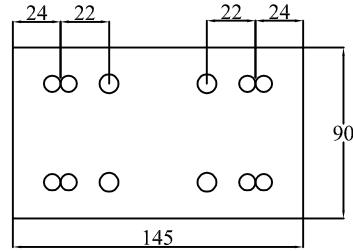

PLAN AT TOP

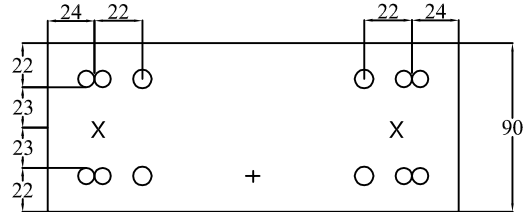

PLAN AT A-A

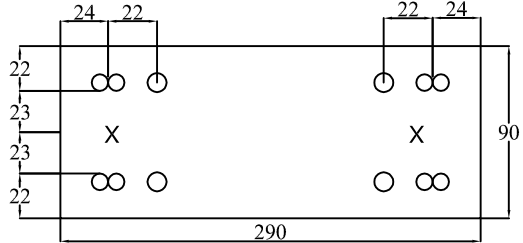

PLAN AT BOTTOM

**NOTE:**

- 1) FACTOR OF SAFETY 2.5
  - 2) CONCRETE GRADE M-420
  - 3) DIAMETER OF PRE STRESSING WIRE 4mm
  - 4) ULTIMATE TENSILE STRENGTH OF PRE STRESSING WIRE Kg/Cm<sup>2</sup> 17500
  - 5) NUMBER OF TENSIONED WIRES 12
  - 6) NUMBER OF UNTENSIONED WIRES 2
  - 7) CONCRETE QUANTITY PER POLE 0.175M<sup>3</sup>
  - 8) STEEL QUANTITY PER POLE 10.25Kg
  - 9) WEIGHT OF POLE 380Kg
  - 10) CLEAR COVER TO WIRE 20mm
  - 11) LOCATION OF HOLES AS PER REC STANDARDS
- - DENOTES TENSIONED WIRE
  - X - DENOTES UNTENSIONED WIRE
  - + - POSSIBLE POSITION OF EARTH WIRE
- 12) ALL DIMENSIONS ARE IN mm AND DRAWING IS NOT TO SCALE.
  - 13) FOR HOLDING PART LENGTH UNTENSIONED WIRES IN POSITION, 4mm Ø M.S. STRUTS WILL BE USED WITH SUITABLE SPACING.
  - 14) IF ANY PRACTICAL DIFFICULTY IS EXPERIENCED IN USING PART LENGTH INTENTIONED WIRES, FULL LENGTH WIRE WILL BE USED INSTEAD, BUT THE TENSION IN THESE WIRES WILL NOT EXCEED 5% OF THEIR U.T.S. VALUE.

# 10Mtrs /330 Kgs PSC POLE

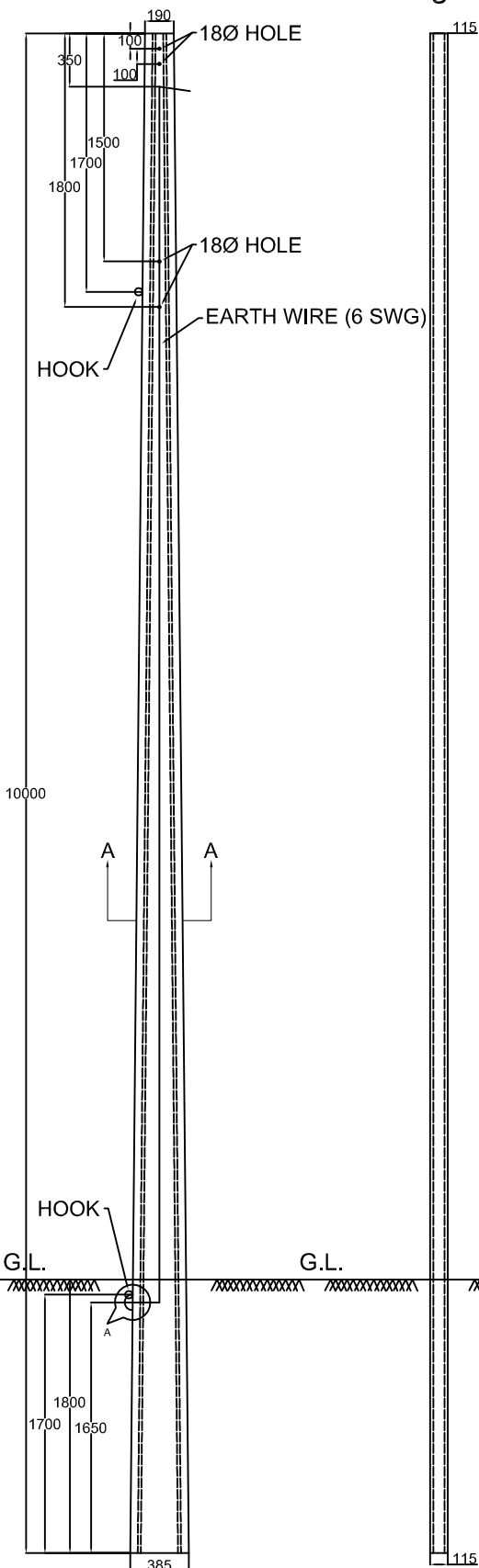

ELEVATION

SIDE VIEW

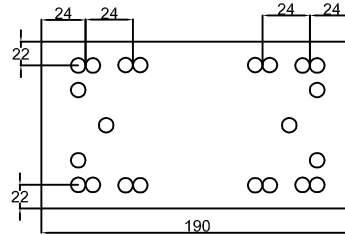

PLAN AT TOP

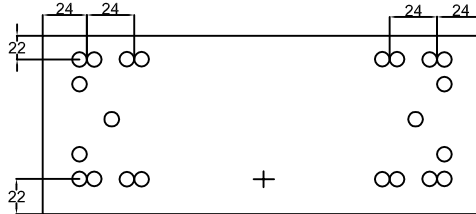

PLAN AT A-A

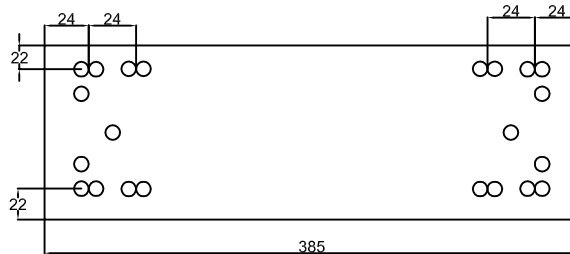

PLAN AT BOTTOM

Note:- FACTOR OF SAFETY 2.5

SL.NO.	DESCRIPTION	QUANTITY
1.	NO. OF. TENSINED WIRES (4MM)	22 NOS.
2.	CONCRETE GRADE	M-420
3.	DIA OF PRESTRESSING WIRE	4MM
4.	WORKING LOAD	330 KGS
5.	ULTIMATE TENSILE STENGTH OF PRESTRESSING WIRE	17500 KG/CM <sup>2</sup>
6.	PLANTING DEPTH	1800MM
7.	CLEAR COVER	22 MM
8.	G.I. EARTH WIRE 6 SWG	1 NO.

LEGEND:-

- - DENOTES TENSINED WIRE
- + - DENOTES POSSIBLE OF EARTH WIRE

- ALL DIMENSION ARE NOT IN SCALE

# 10Mtrs/400 Kg PSC POLE

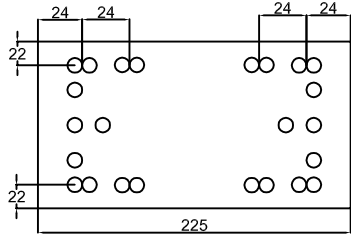
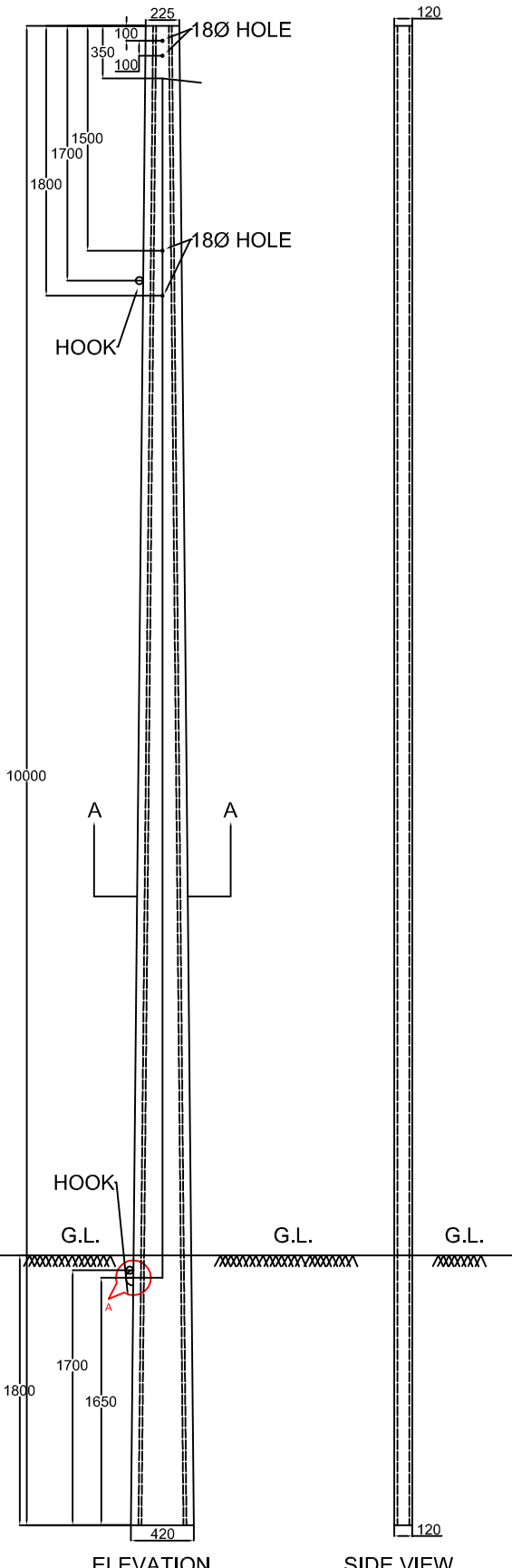

PLAN AT TOP

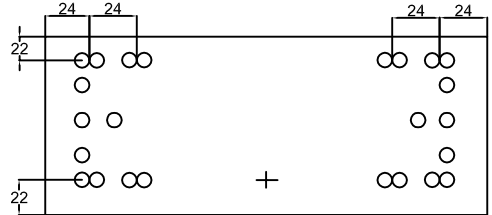

PLAN AT A-A

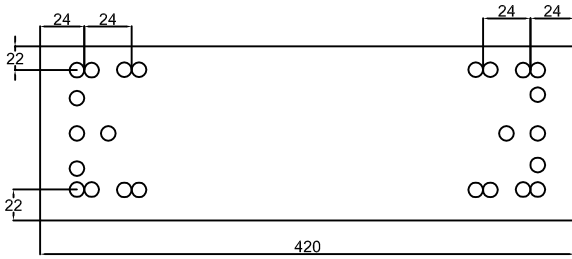

PLAN AT BOTTOM

Note:- FACTOR OF SAFETY 2.5

SL.NO.	DESCRIPTION	QUANTITY
1.	NO. OF. TENSINED WIRES (4MM)	24 NOS.
2.	CONCRETE GRADE	M-420
3.	DIA OF PRESTRESSING WIRE	4MM
4.	WORKING LOAD	400 KGS
5.	ULTIMATE TENSILE STRENGTH OF PRESTRESSING WIRE	17500 KG/CM <sup>2</sup>
6.	PLANTING DEPTH	1800MM
7.	CLEAR COVER	22 MM
8.	G.I. EARTH WIRE 6 SWG	1 NO.

LEGEND:-

- - DENOTES TENSIONED WIRE
- + - DENOTES POSSIBLE OF EARTH WIRE

-ALL DIMENSION ARE NOT IN SCALE

CESU CAPEX



# 11 KV V-CROSS ARMS WITH TOP BRACKET & BACK CLAMP FOR PSC POLE

FABRICATED FROM 70X70X6 G.I. ANGLE

LENGTH OF POLE (L)	LOAD(KG)	A	B	C	D	BOTTOM LINE OF X-ARM FROM TOP OF THE POLE IN mm
10000 mm minimum	330	216	276	111	362	1170

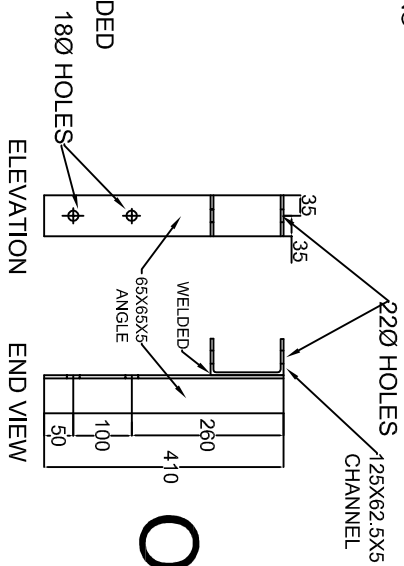
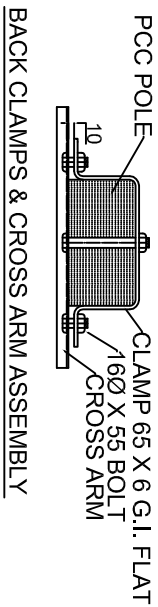
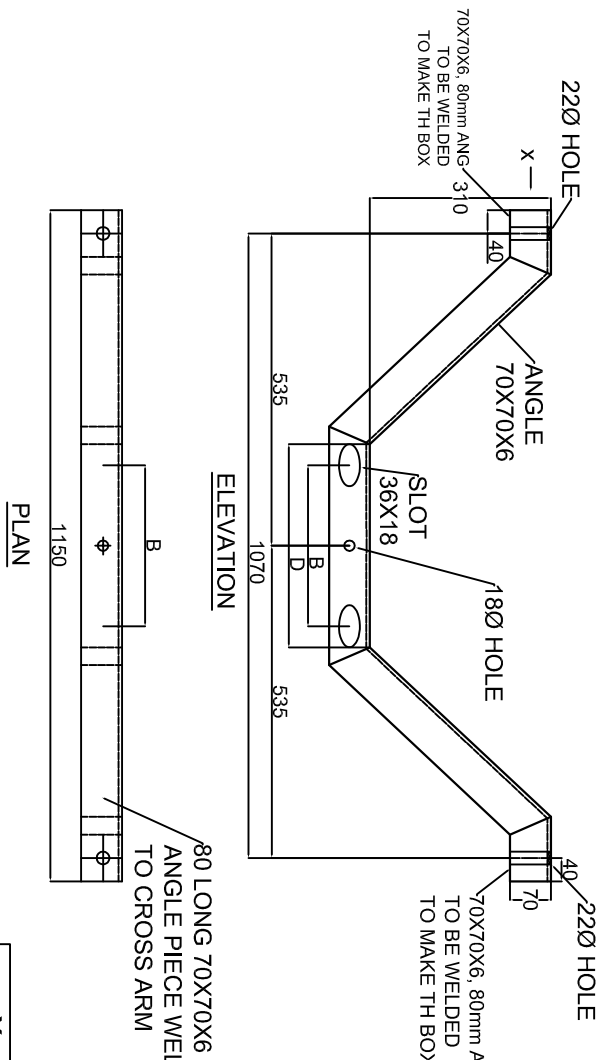

POLE TOP BRACKET

OR

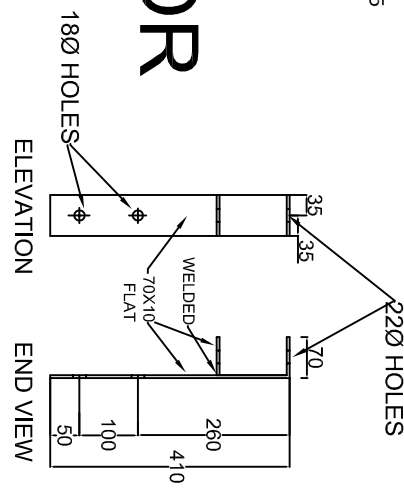

POLE TOP BRACKET

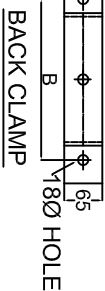
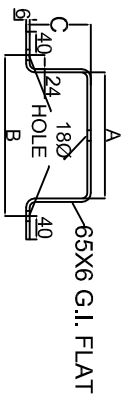
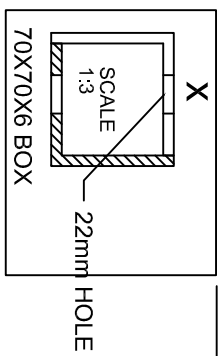

# 11kV V-CROSS ARM FOR RS JOIST

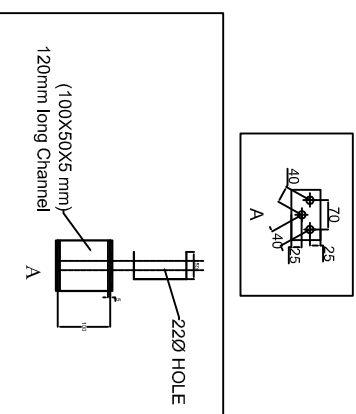
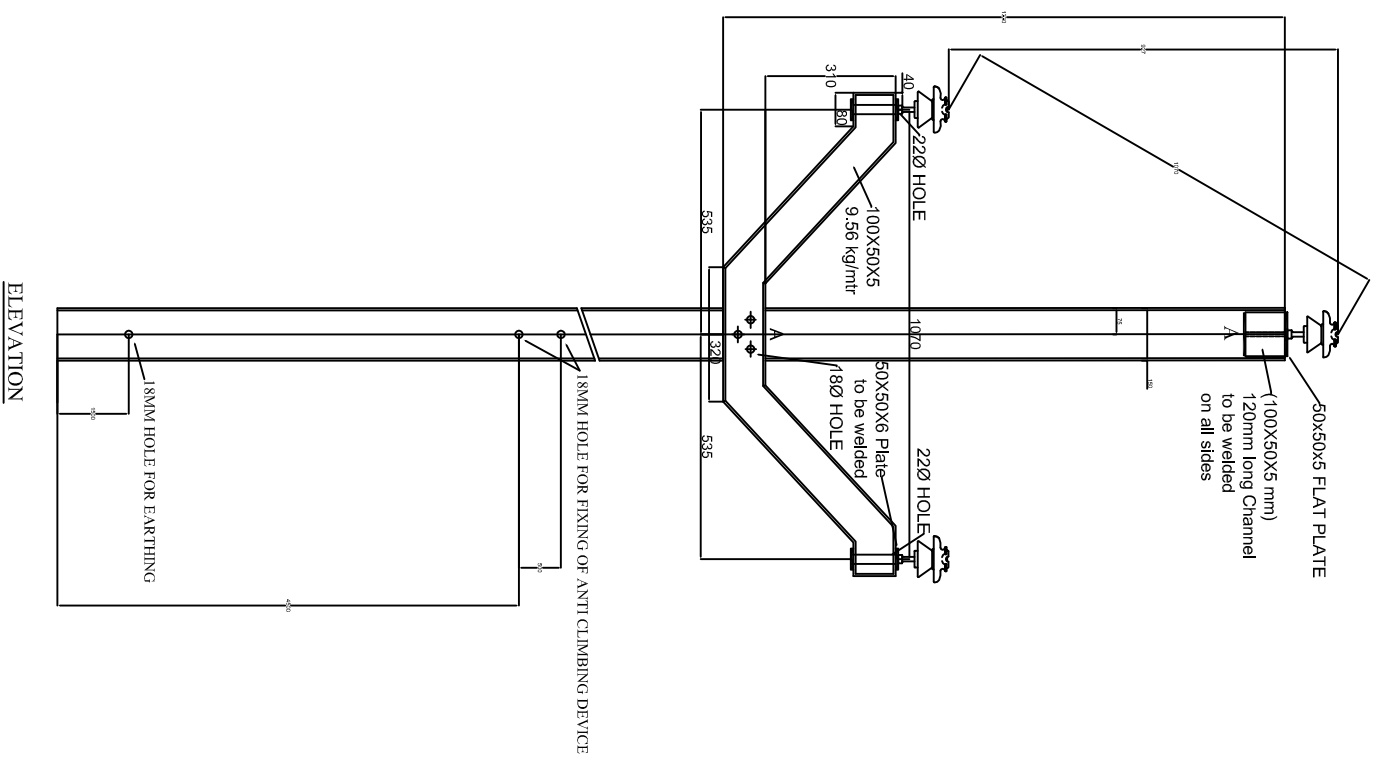

# 11kV V-CROSS ARM FOR RS JOIST

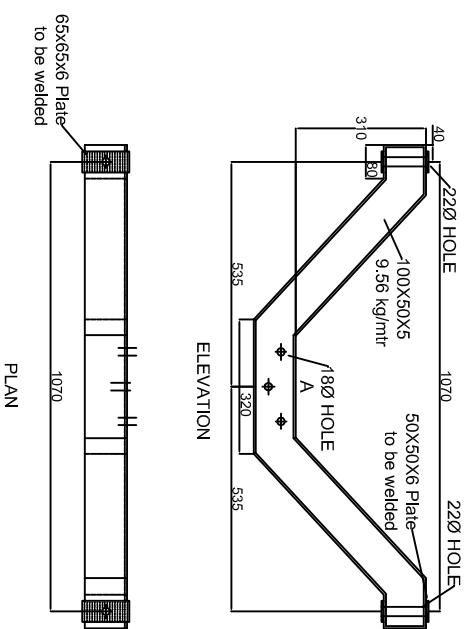

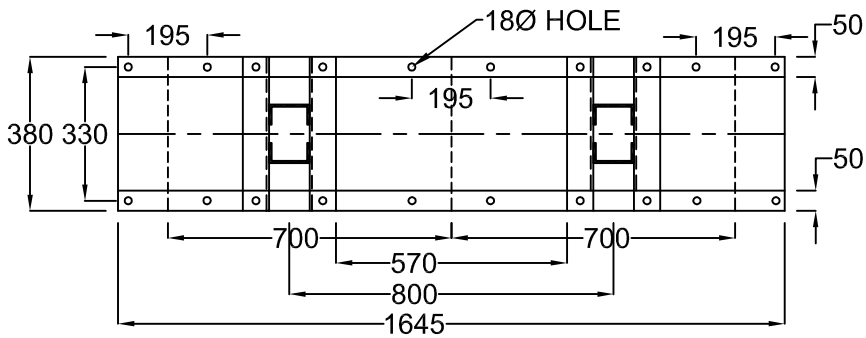

**PLAN**

**11 KV CT**

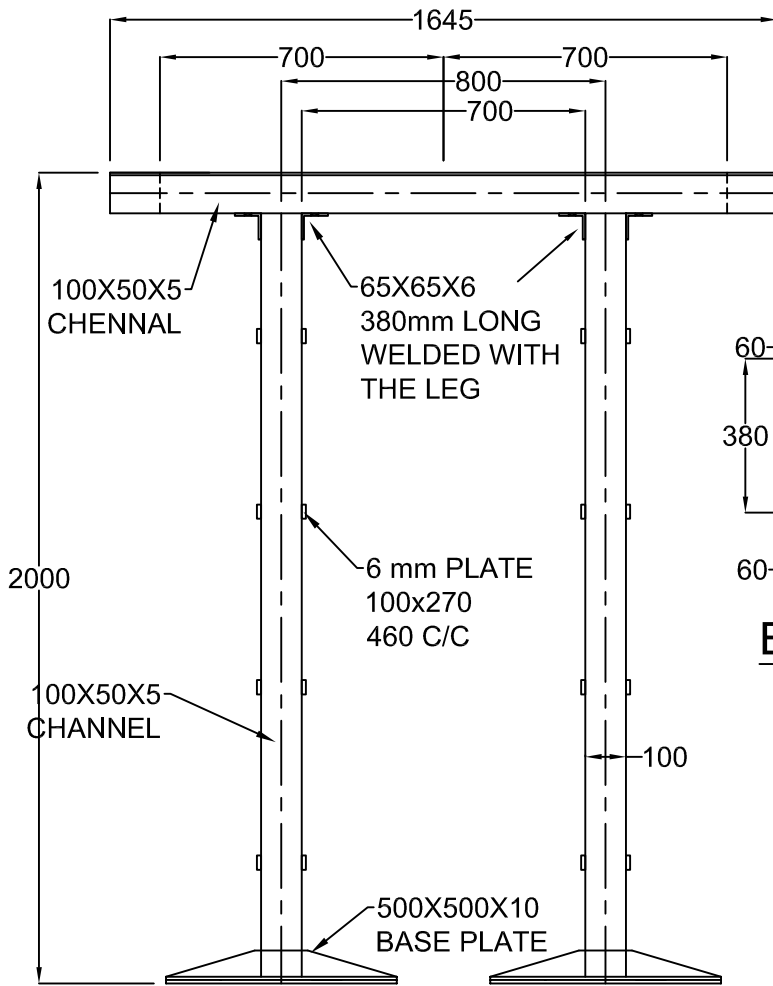

**ELEVATION**

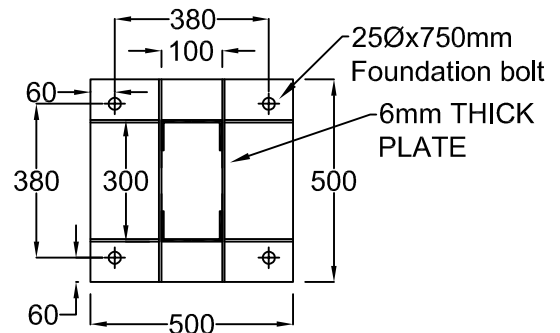

**BASE PLATE**

**REV- 1**

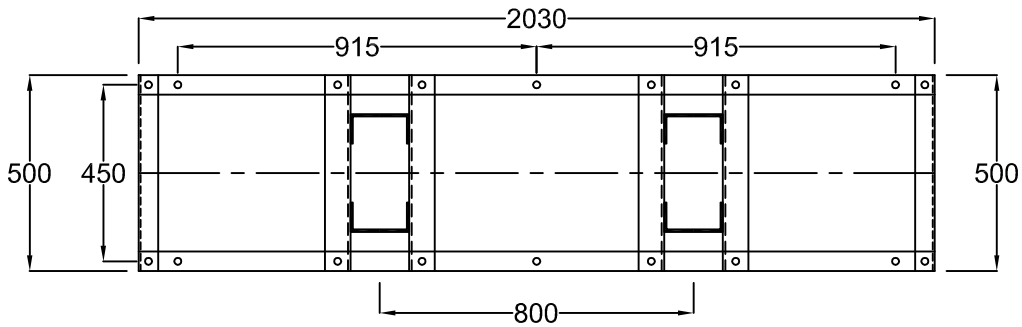

PLAN

11 KV SI

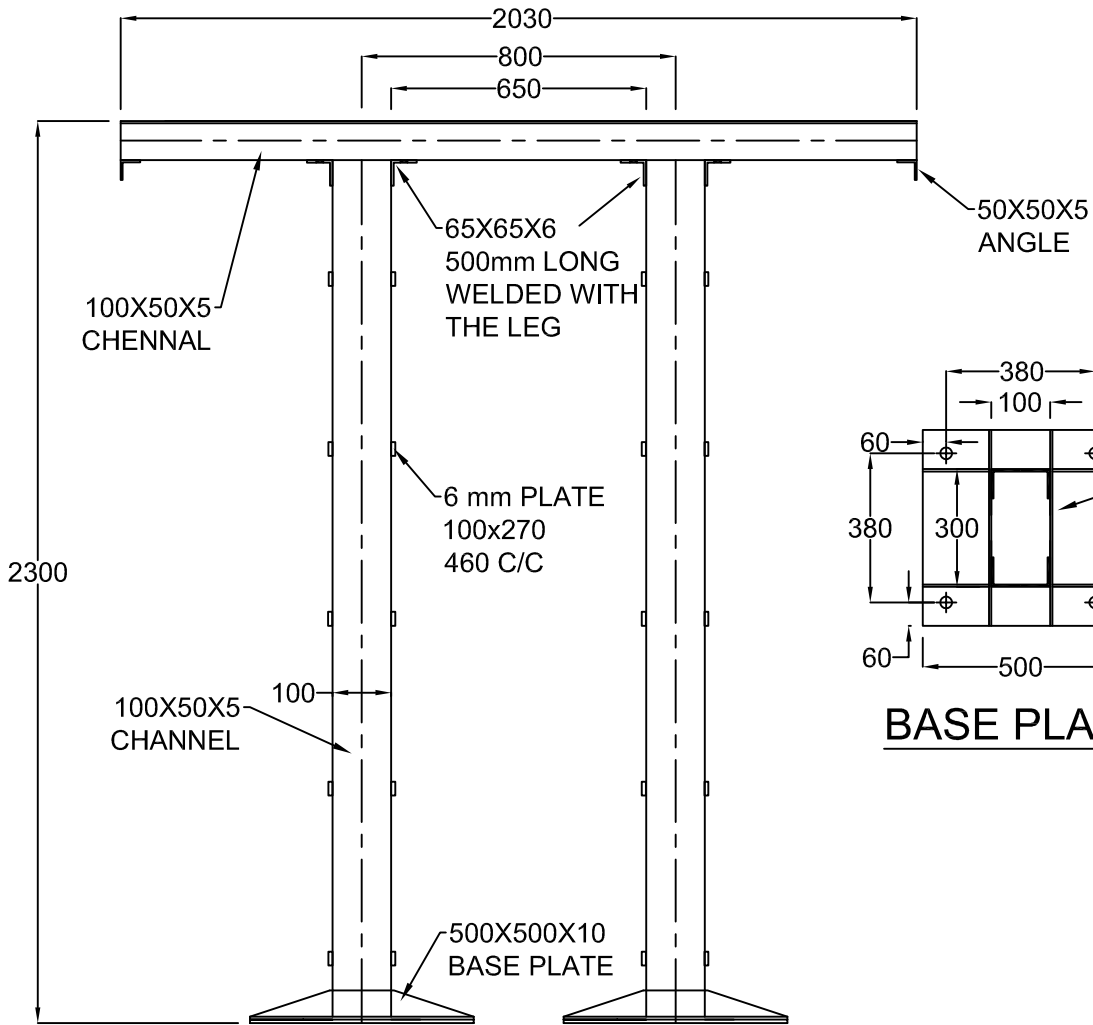

ELEVATION

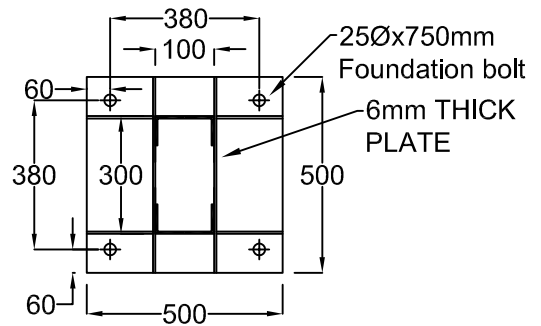

BASE PLATE

REV- 1

# 33 KV V-CROSS ARMS WITH POLE TOP BRACKET & BACK CLAMP FOR PSC POLE

## CESU-CAPEX

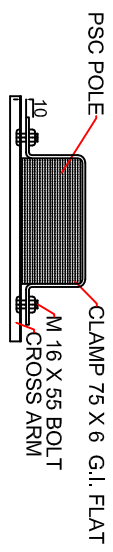
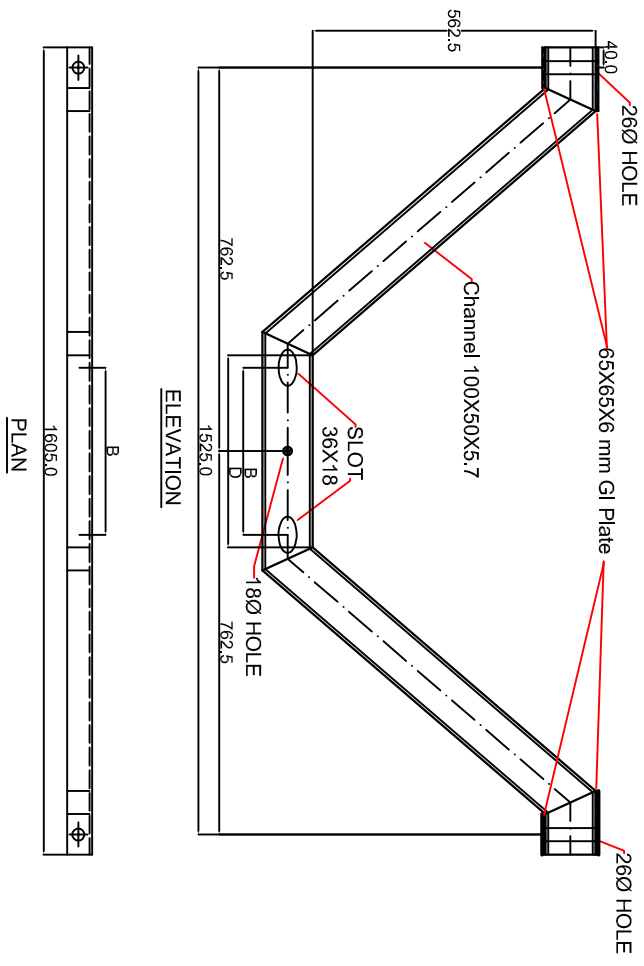

SL. NO.	LENGTH OF POLE (L)	LOAD(KG)	A	B	C	D	CENTER LINE OF X-ARM FROM TOP OF THE POLE IN mm
01	10000 mm minimum	400	258	332	115	382	1800
02		330	225	299	111	362	1800

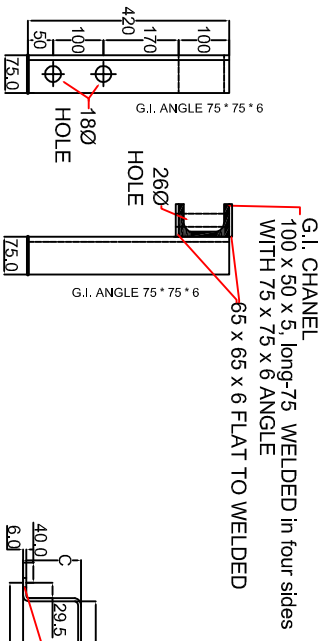

END VIEW  
POLE TOP BRACKET

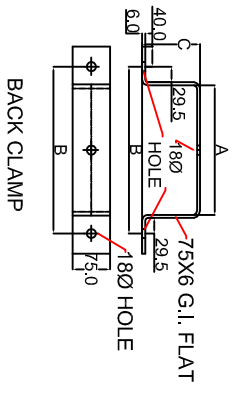

## CESU CAPEX

# 33KV V-CROSS ARM FOR RS JOIST

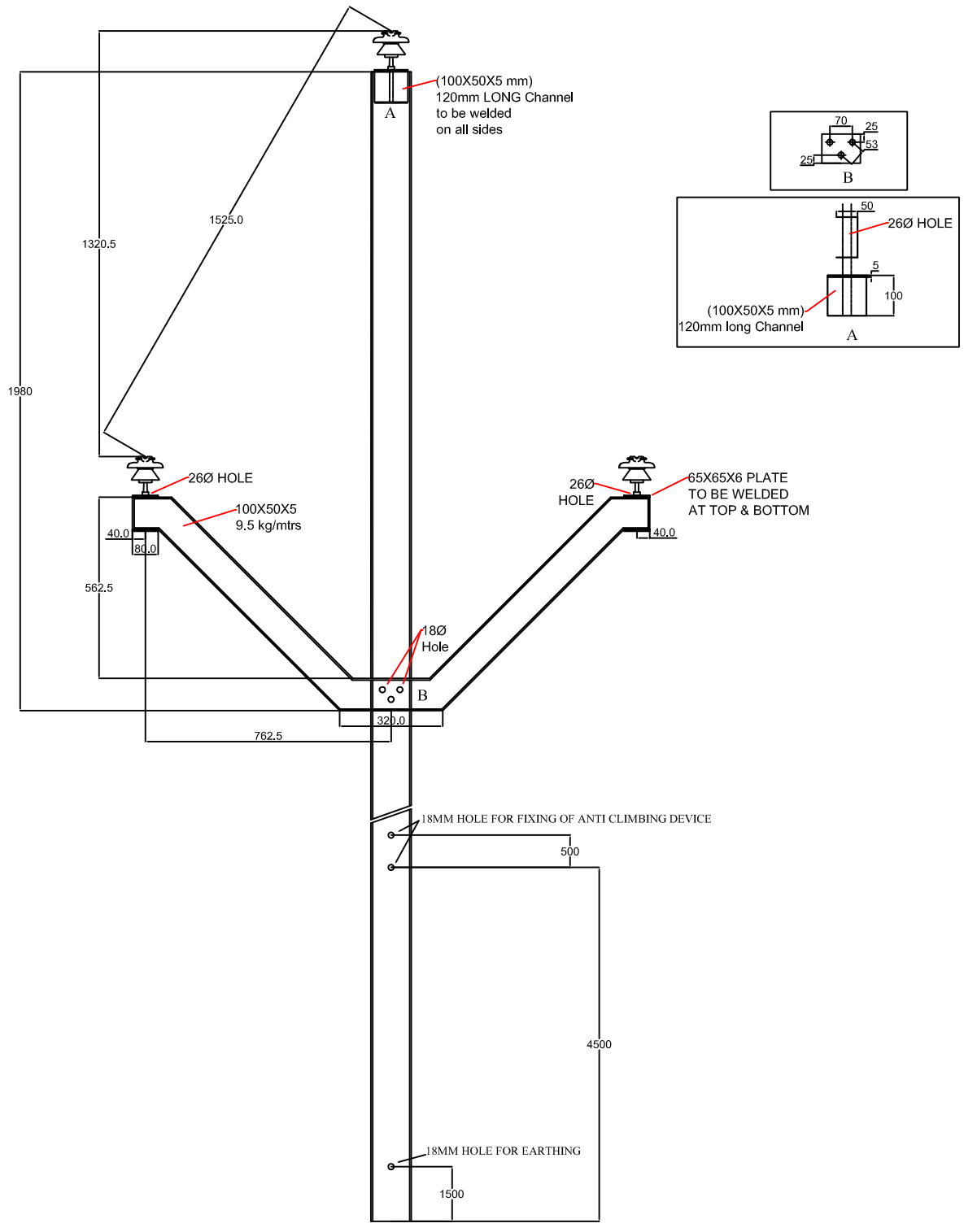

ELEVATION

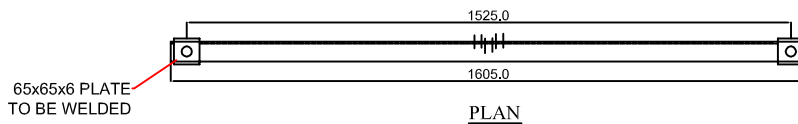

# 33 KV CT

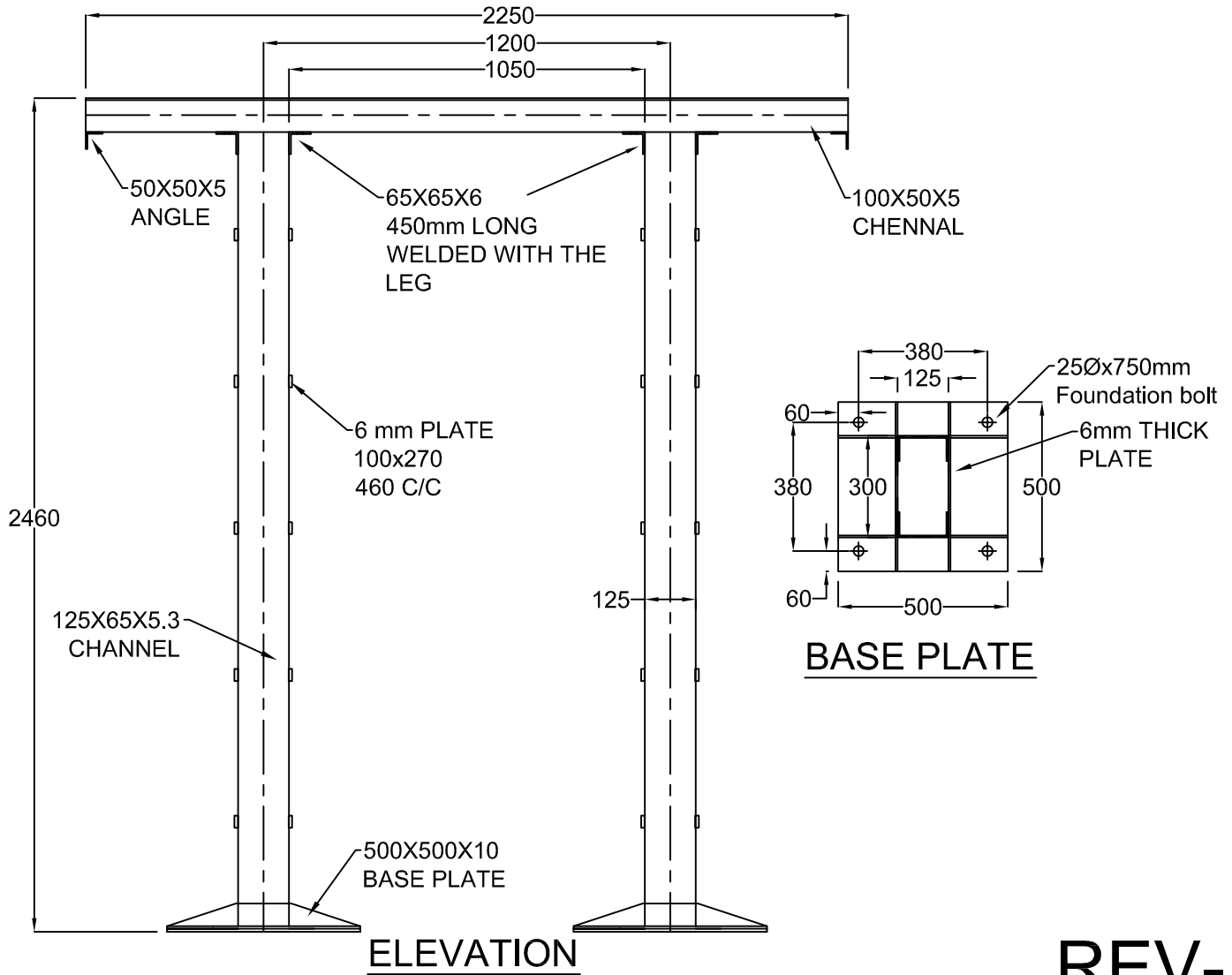
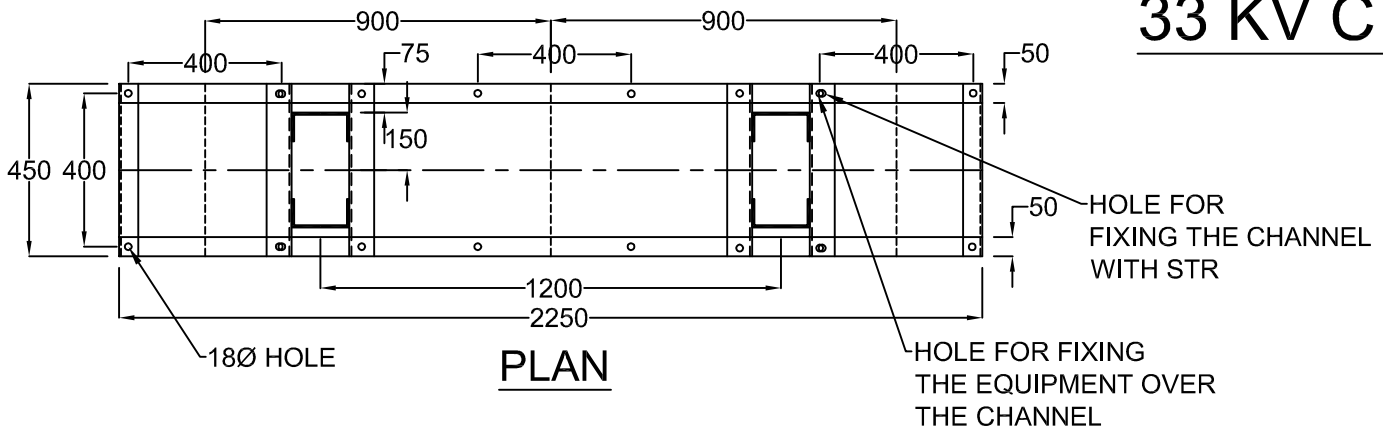

REV- 1

# 33 kv LA

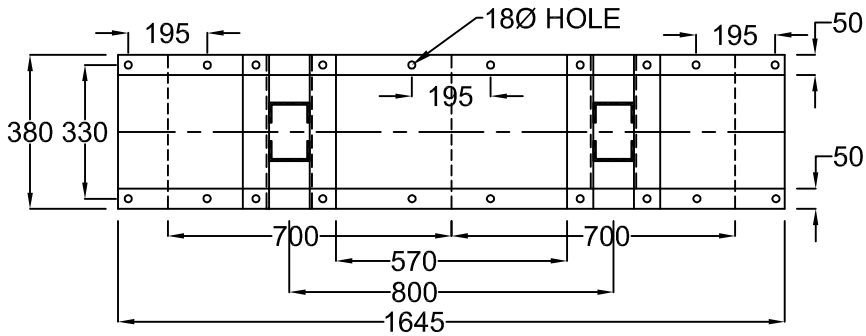

**PLAN**

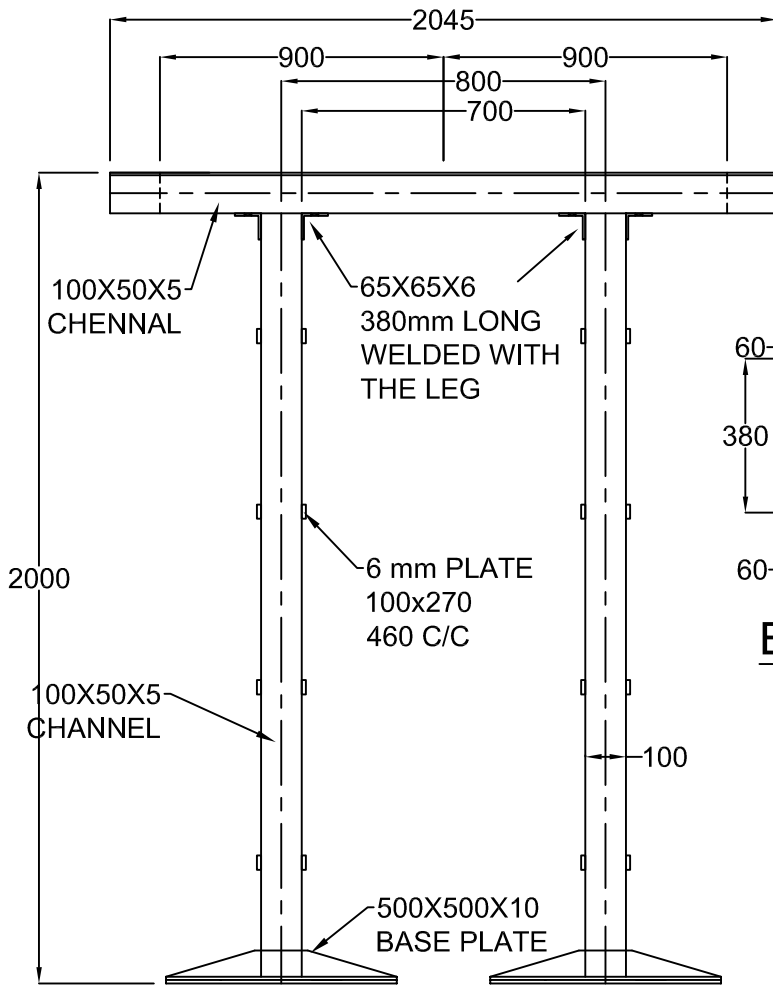

**ELEVATION**

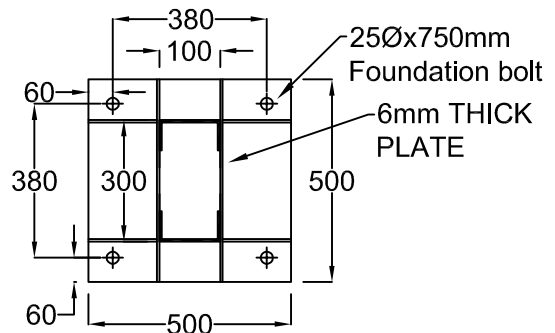

**BASE PLATE**



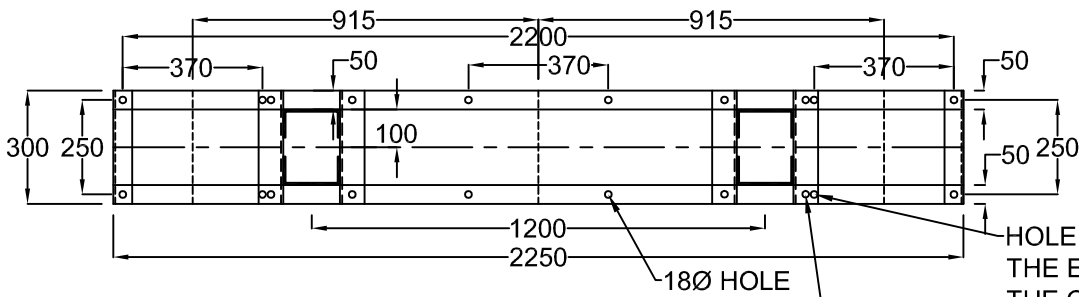

**PLAN**

HOLE FOR FIXING THE EQUIPMENT OVER THE CHANNEL  
 HOLE FOR FIXING THE CHANNEL WITH STR

**33 KV PT**

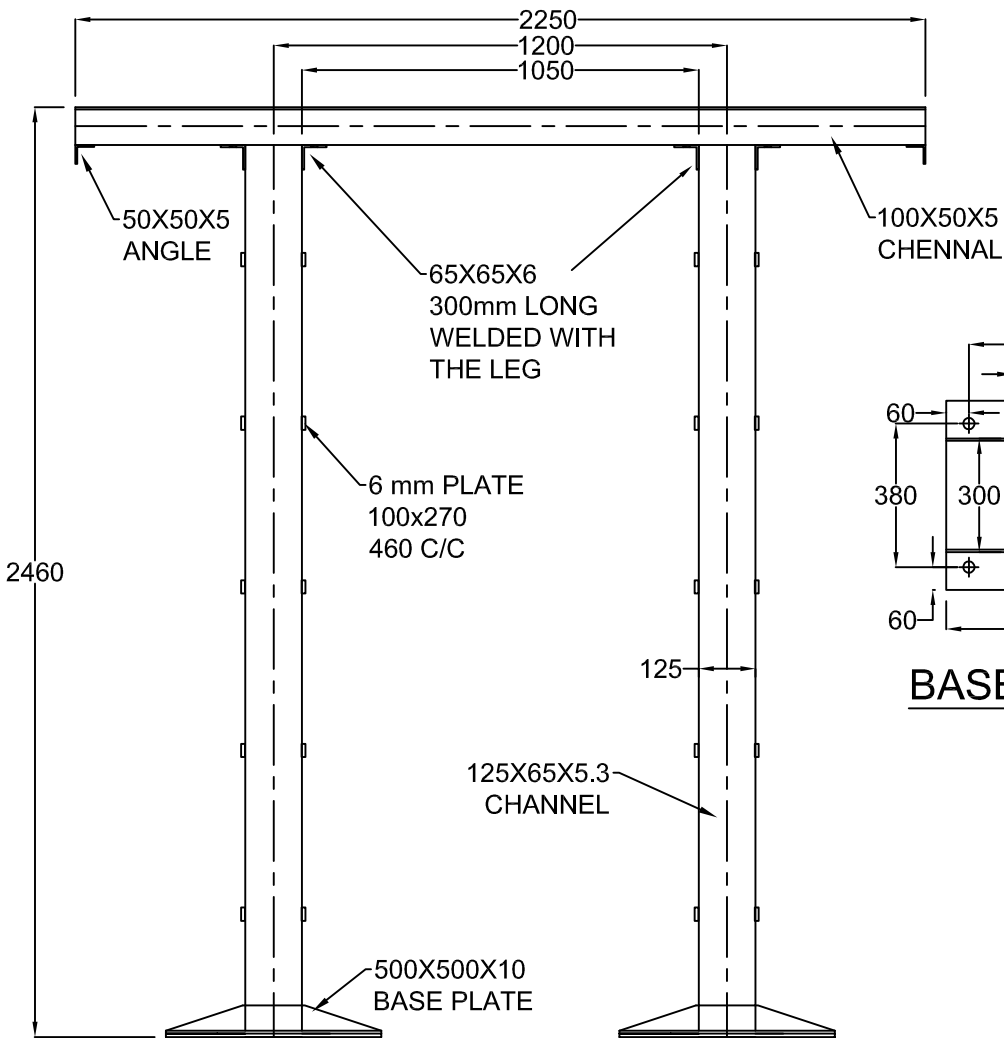

**ELEVATION**

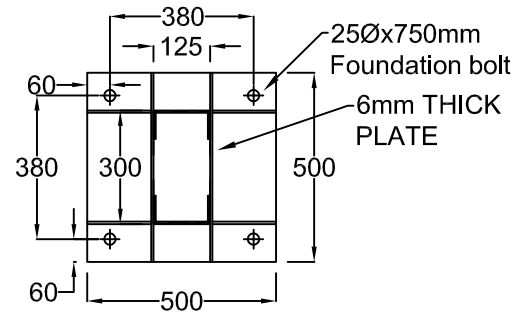

**BASE PLATE**

**REV- 1**

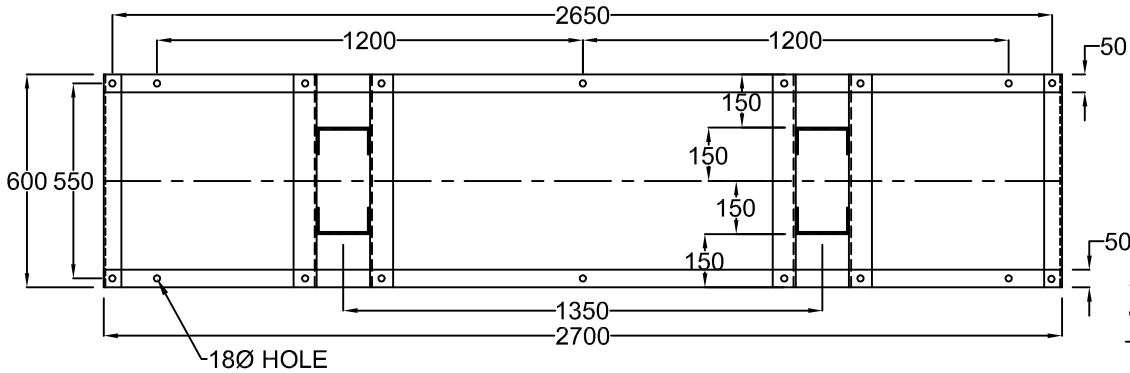

**33 KV SI**

**PLAN**

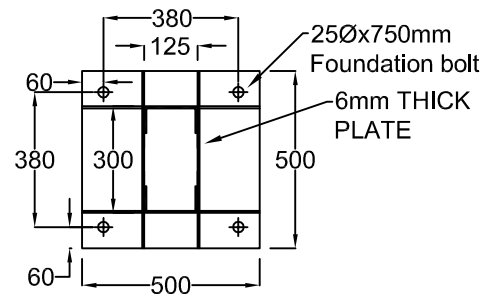
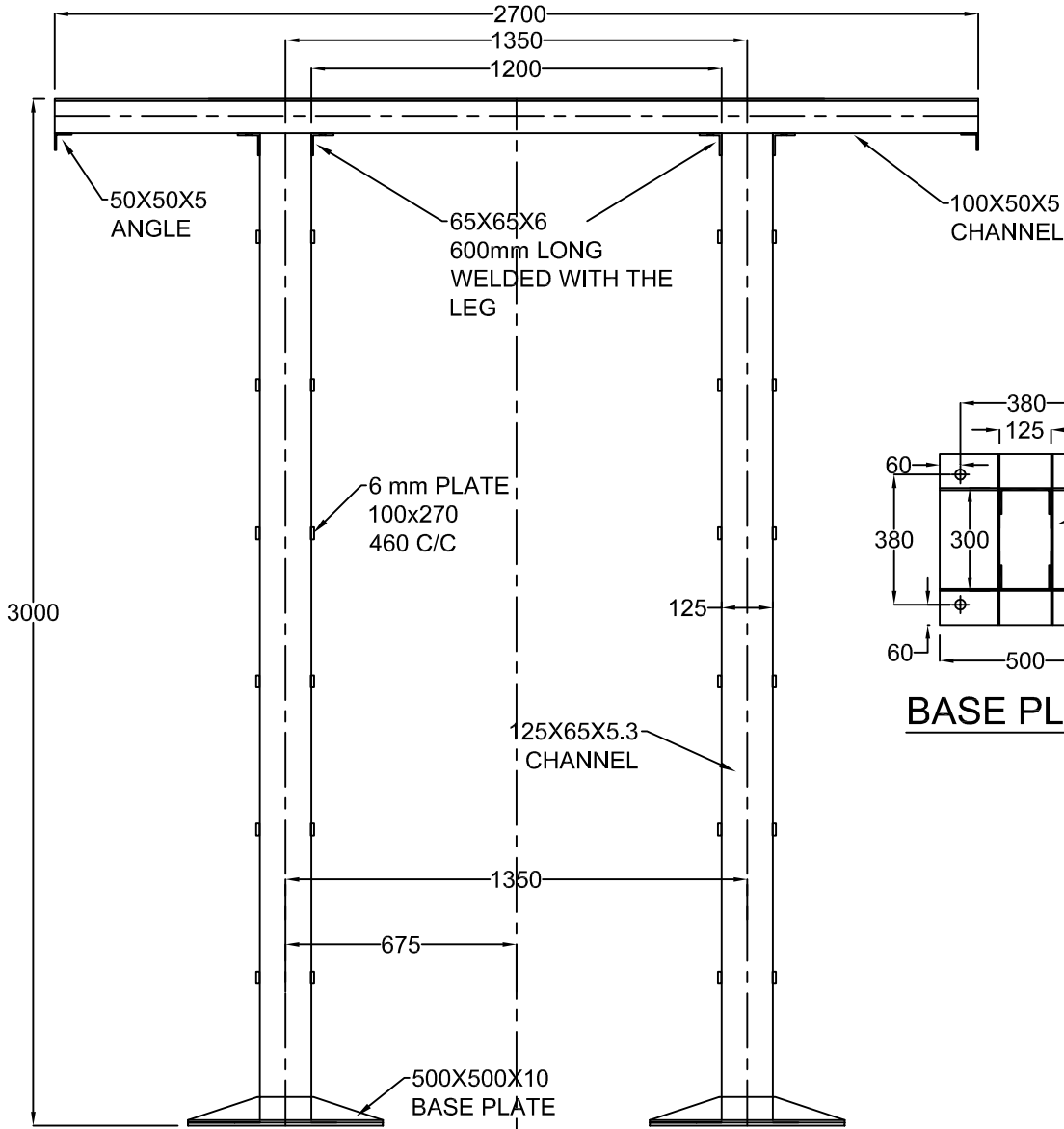

**BASE PLATE**

**ELEVATION**

**REV- 1**

200 KVA D.T. FOUNDATION

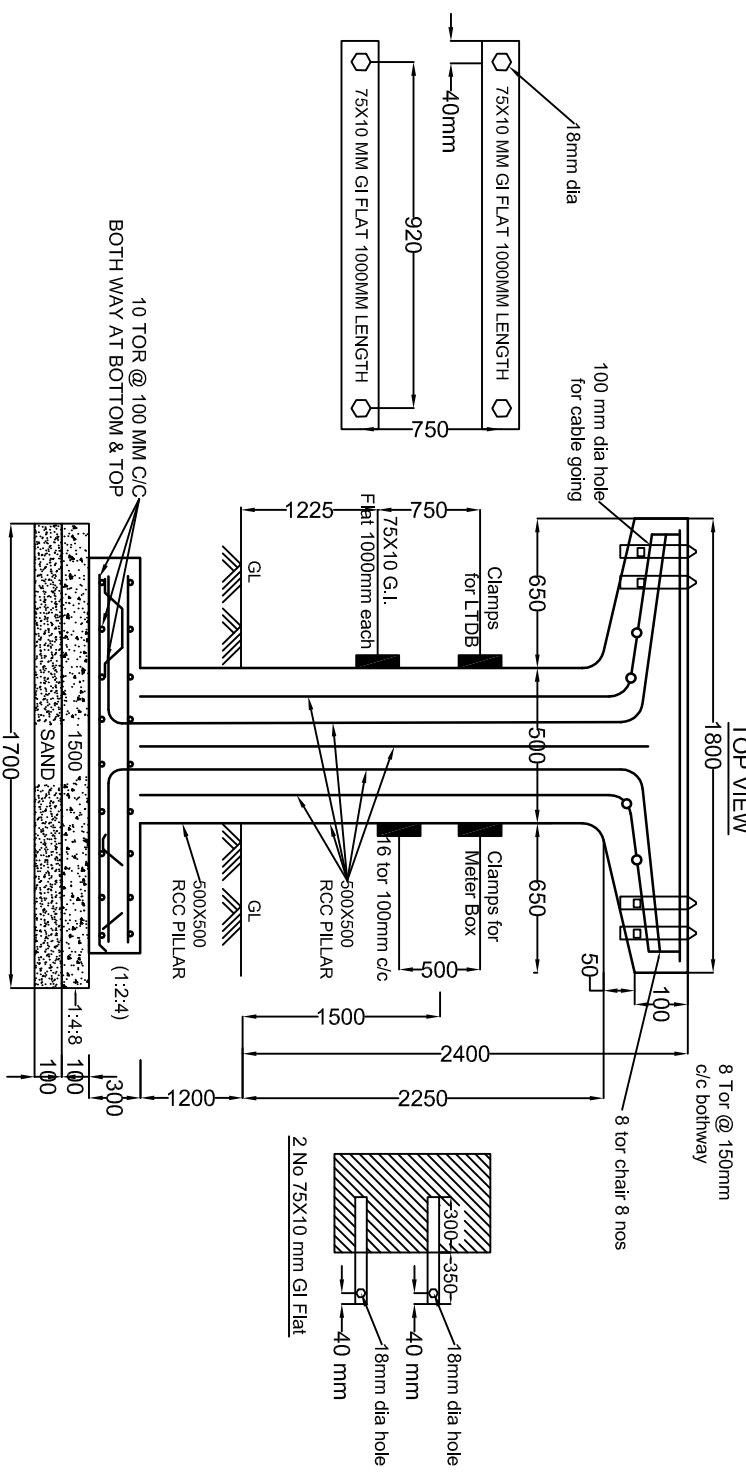
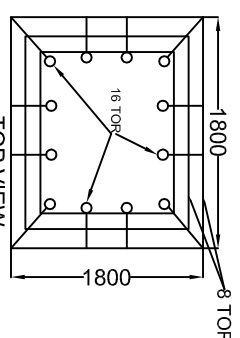

**ROD DETAILS**

<b>PEDESTAL:- 100 MM C/C=</b>
12 Nos:3600+550+300)mm = <b>63.4m</b>
4 legged stirrup:- 8 tor 150mm c/c
22nos:4x(266+400+266+400+100+100)
= <b>134.8m</b>
<b>BOTTOM:- 10 Tor 100mm c/c bothway</b>
(16 nos x 1.45m) x 2 = <b>46.4m</b>
For 2 Layers:- 46.4 x 2 = <b>92.8</b>
Chair:- 10 Tor
4No x (150+150+300+150+150) = <b>8.6m</b>
<b>TOP:- 8 TOR 150mm c/c bothway</b>
2 x 12 nos x 1.65m = <b>39.6m</b>
Chair:- 10 tor
8 nos x 1.50m = <b>12m</b>

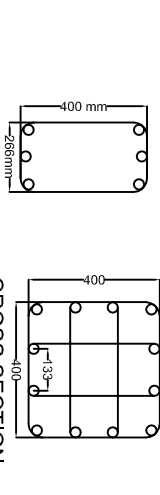
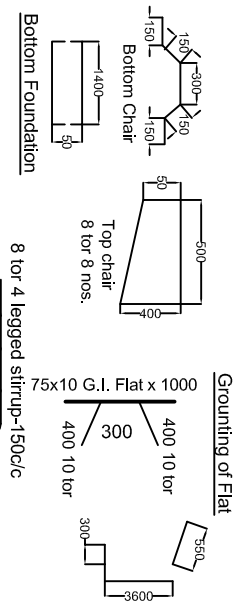

ARRAIGNMENT OF SPIKES  
WITH COLUMN STRUCTURE

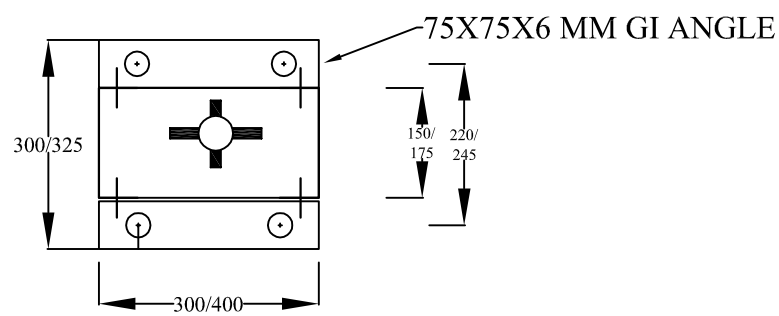
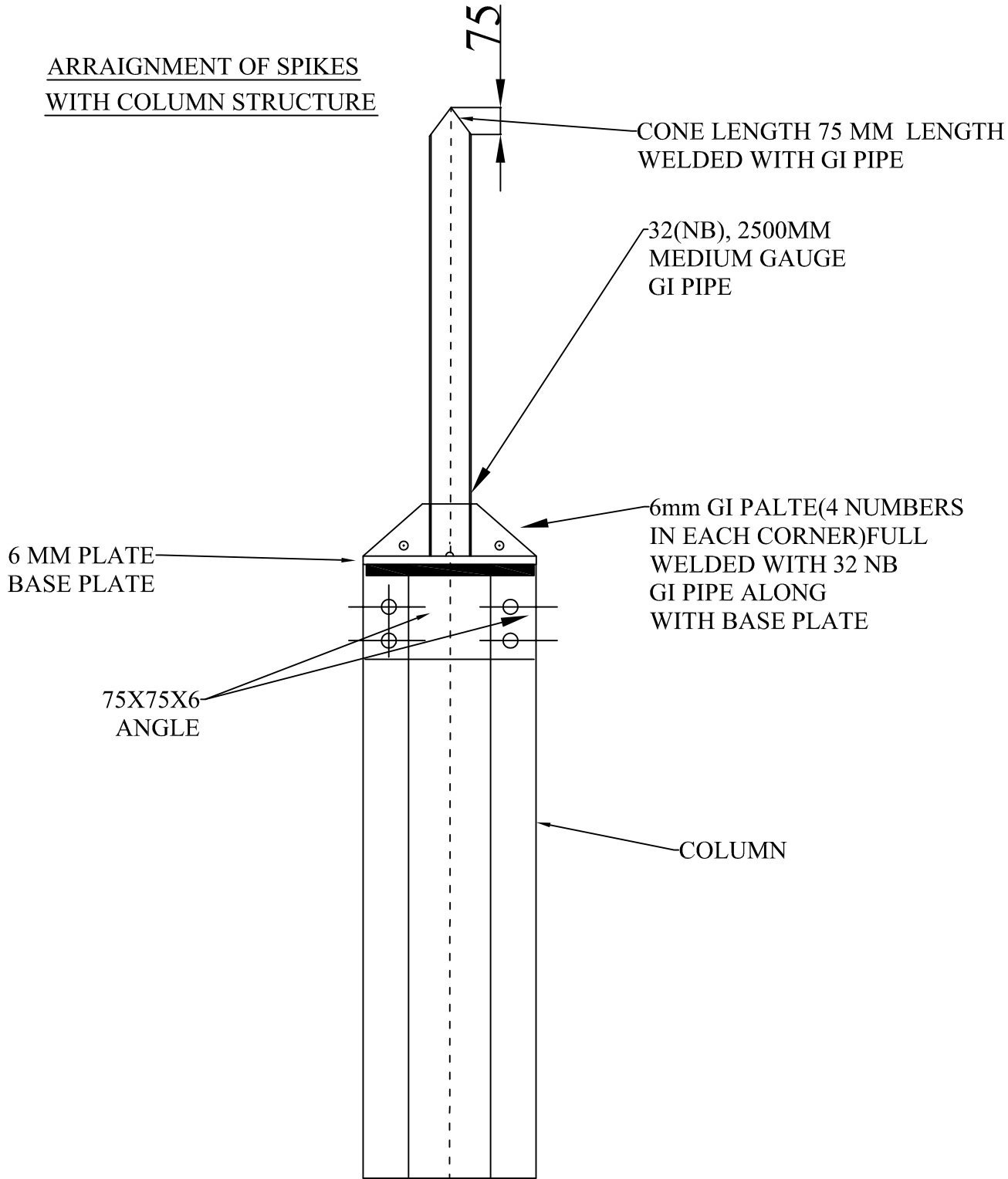

TOP PLAN OF  
STRUCTURE



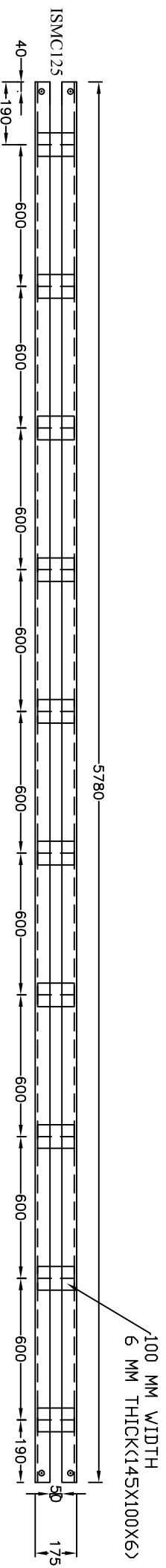

G2-AX(TO BE USED IN NUAPADA S/S).

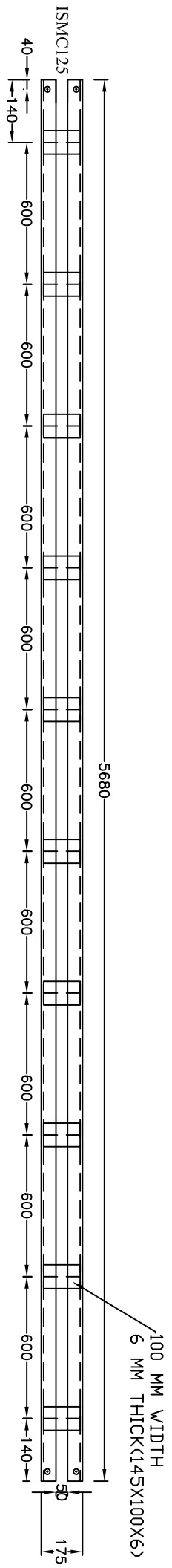

G2X.(RCMS EXTENT)



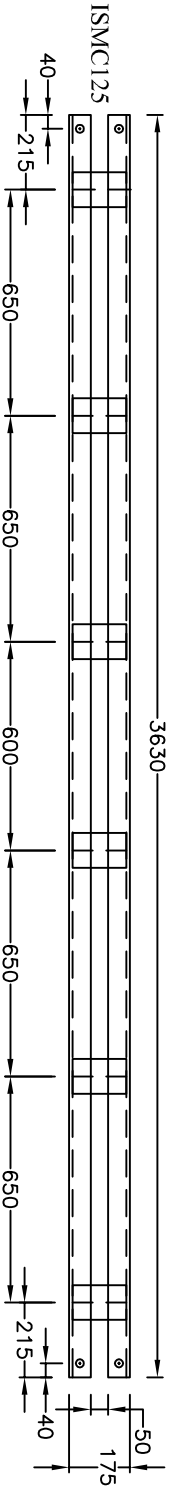

G7A

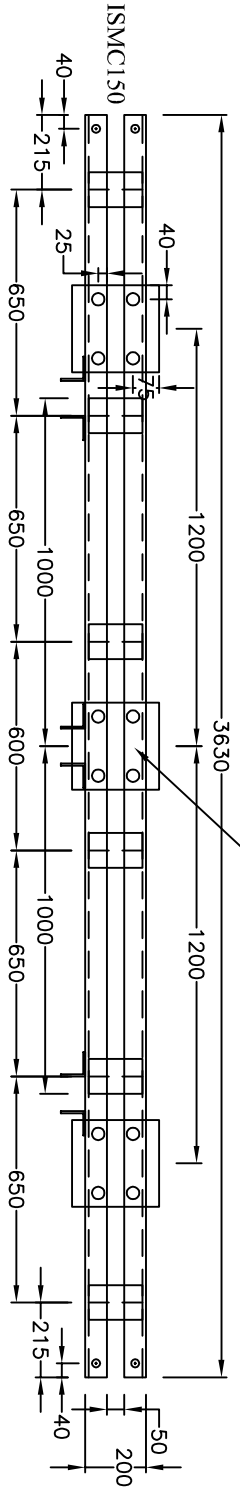

G7B

250X250X6MM  
GI PLATE

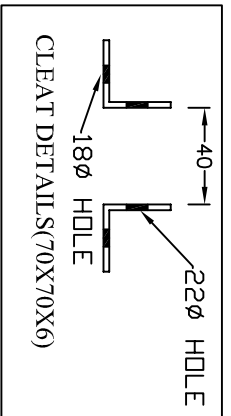





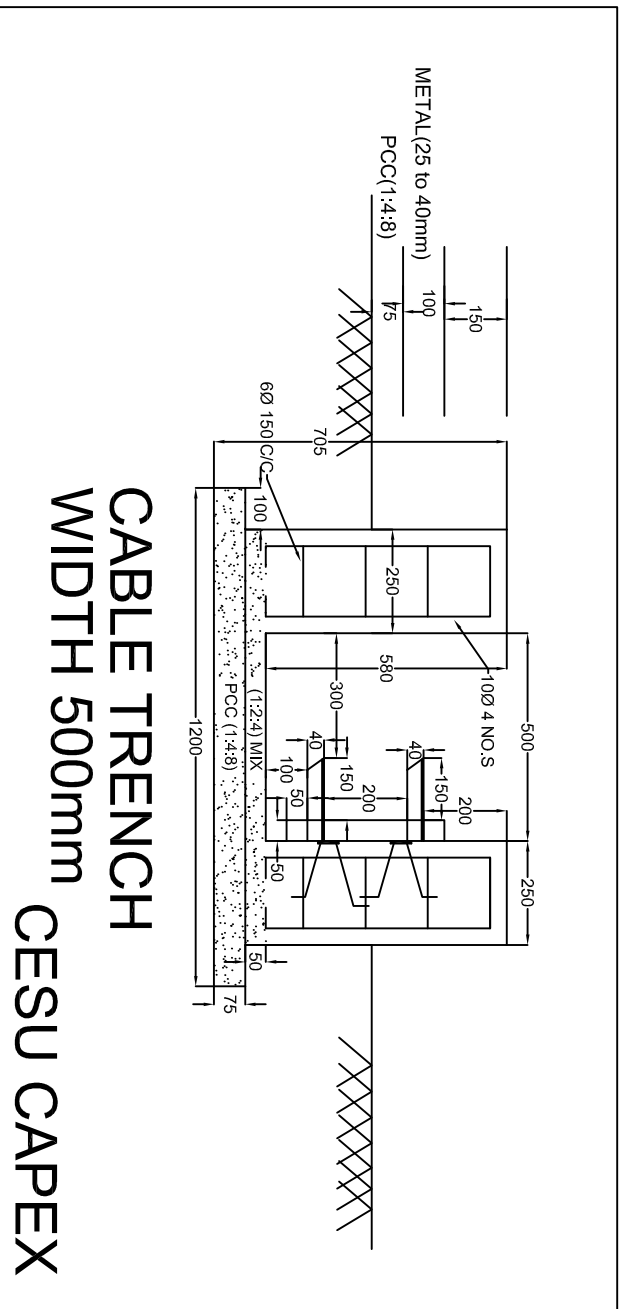

**CABLE TRENCH  
WIDTH 500mm  
CESU CAPEX**

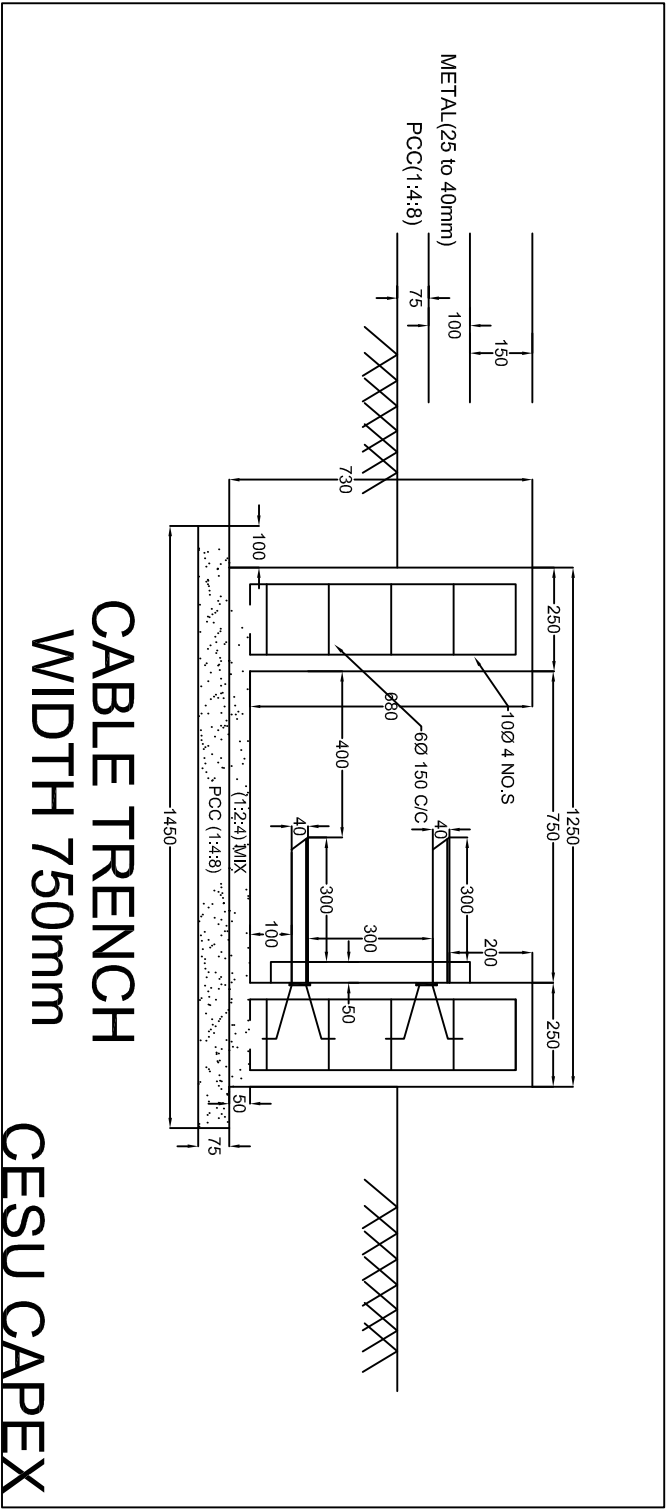

**CABLE TRENCH  
WIDTH 750mm  
CESU CAPEX**

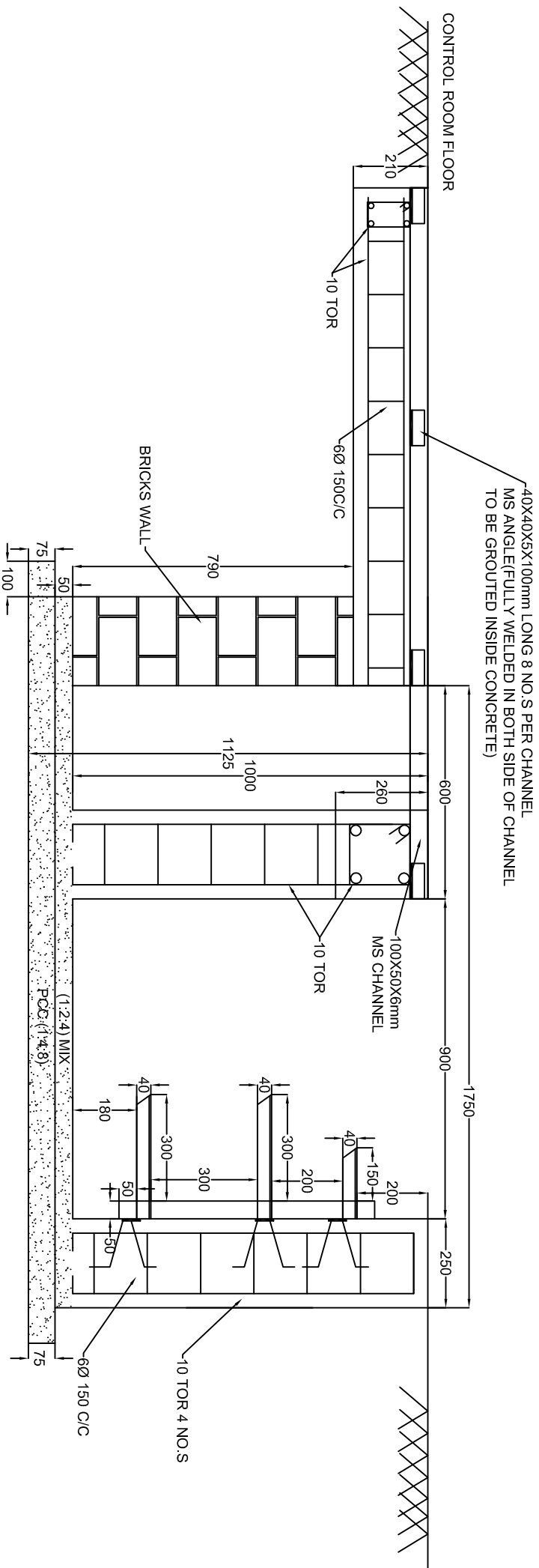

**ELEVATION OF CABLE TRENCH  
WIDTH OF 1500mm**

**CESU CAPEX**

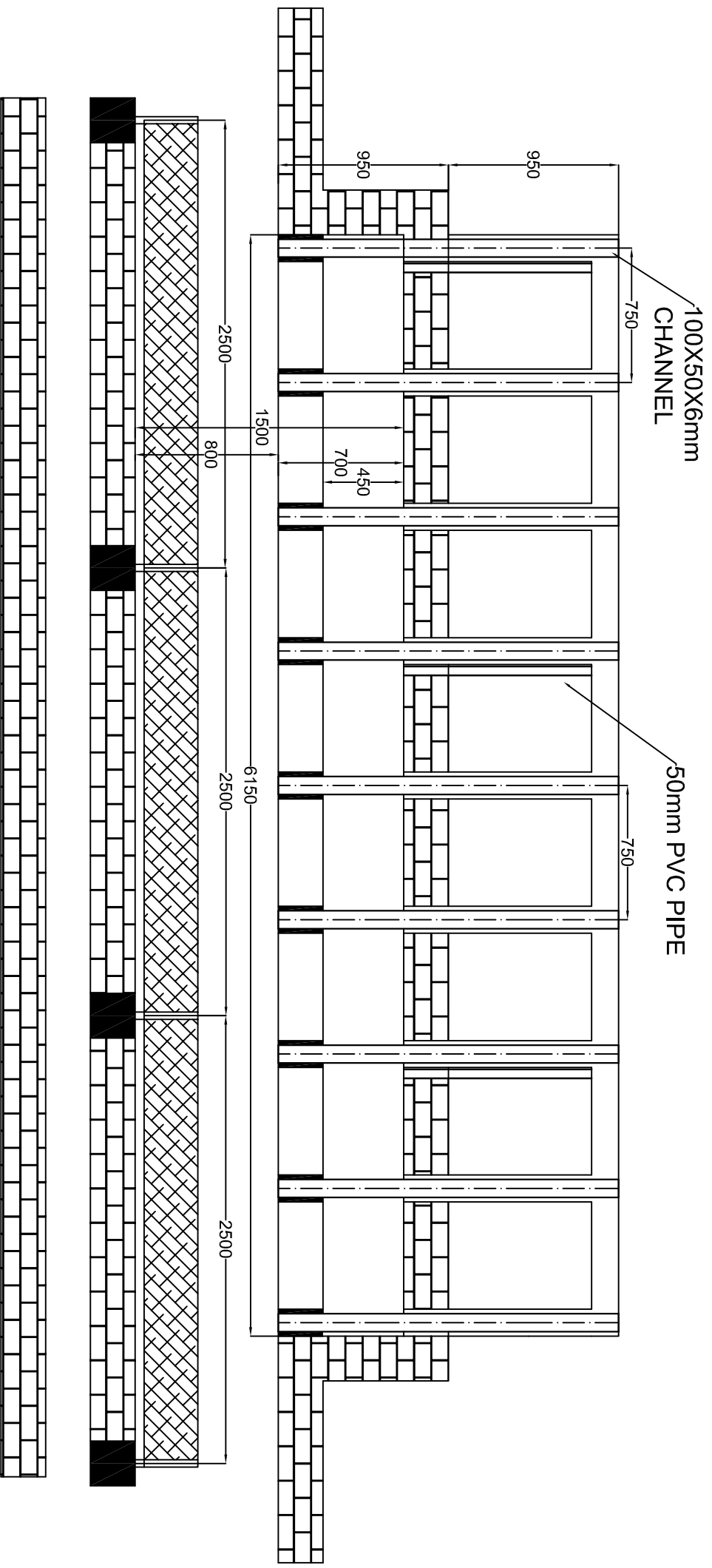

PLAN OF CABLE TRENCH FOR 11KV INDOOR PANEL

CESU CAPEX

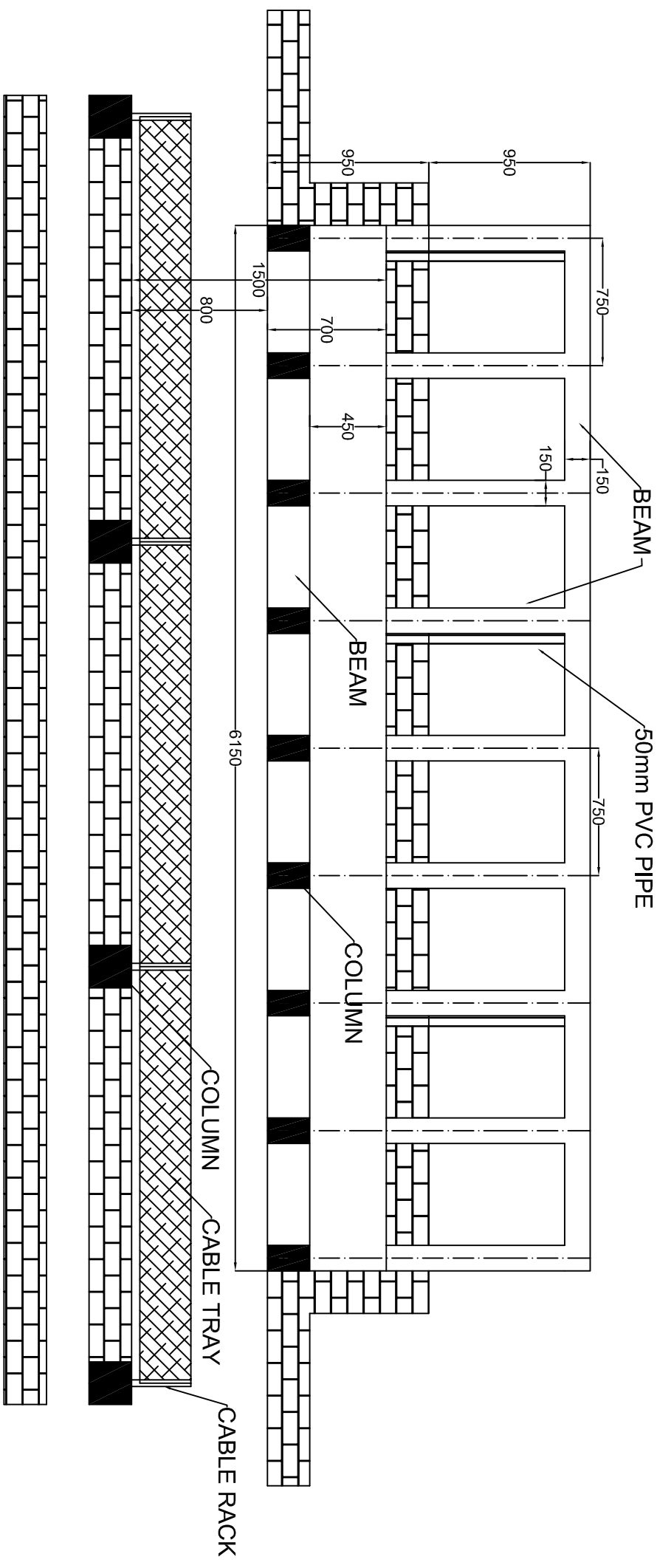

PLAN OF CABLE TRENCH FOR 11KV INDOOR PANEL  
 SHOWING COLUMN, BEAM, BRICKS WALL

CESU CAPEX



G1X = 4330 = 1NO WITH 33KV LA  
 G1Y = 4330 = 1NO WITH 33KV ABS  
 G1Z = 4330 = 1NO WITH 33KV HG FUSE

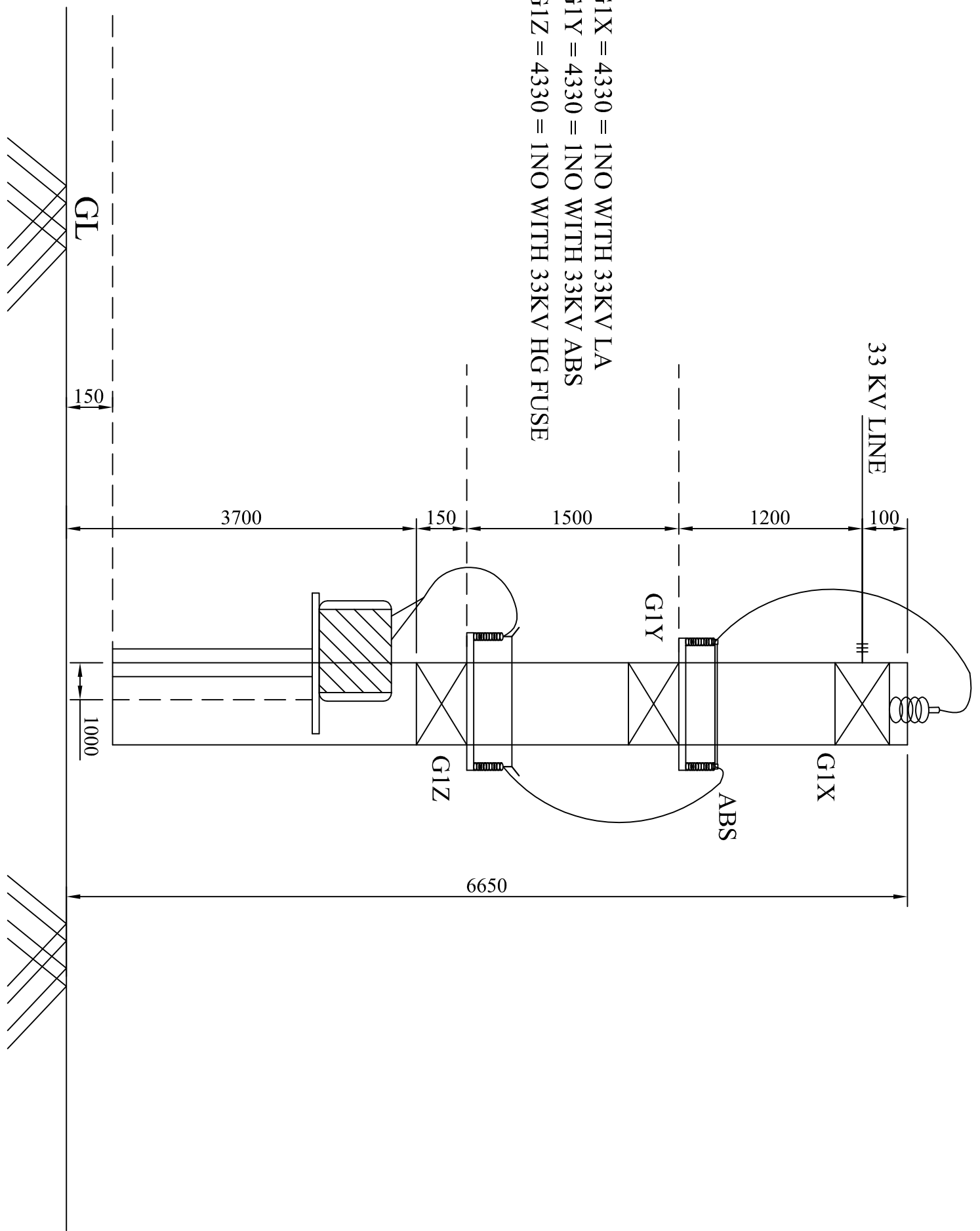

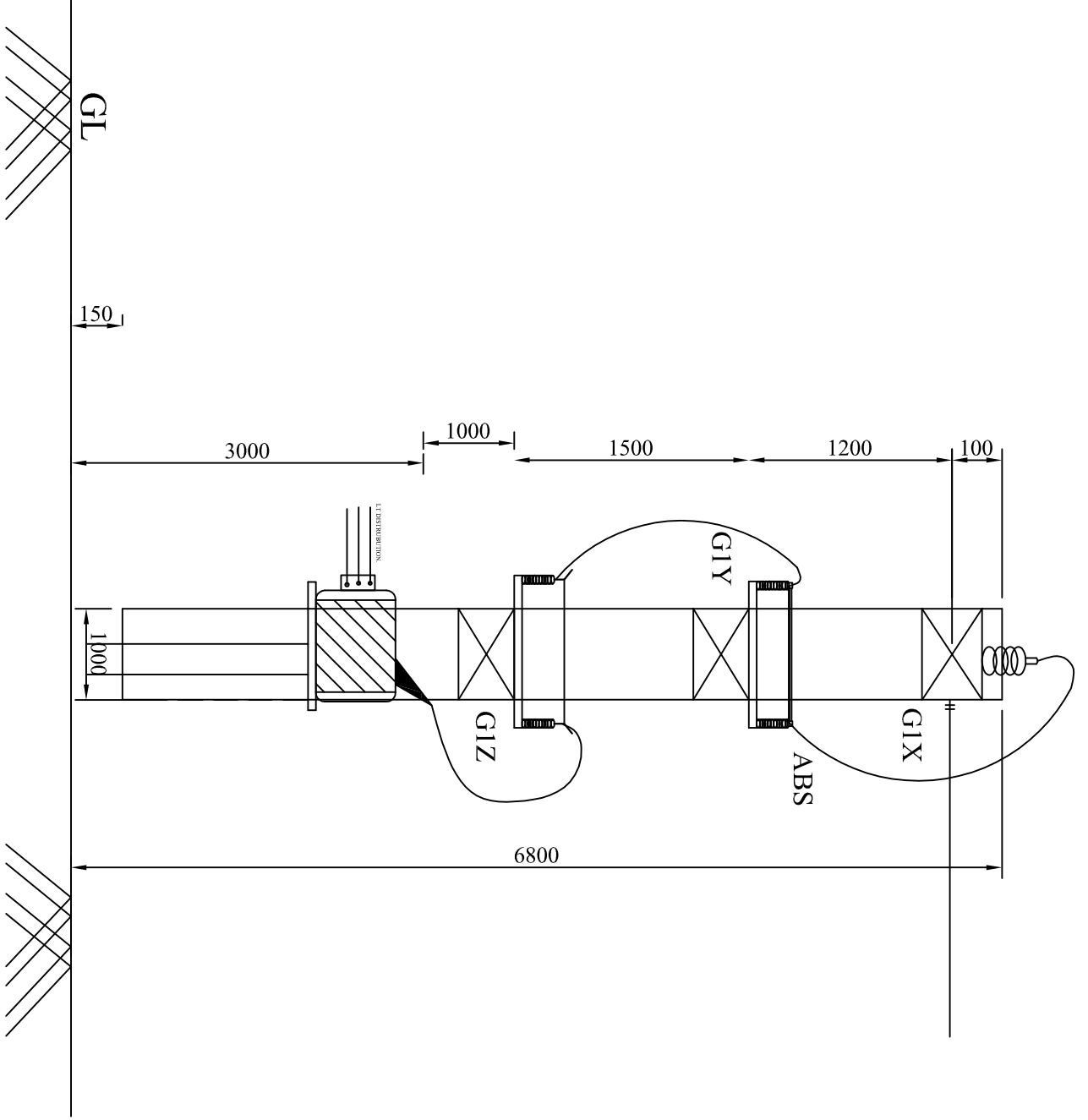

11 KV DP STR.

CESU CAPEX



## DP STRUCTURE FOR 11/33kv(PSC & JOIST)

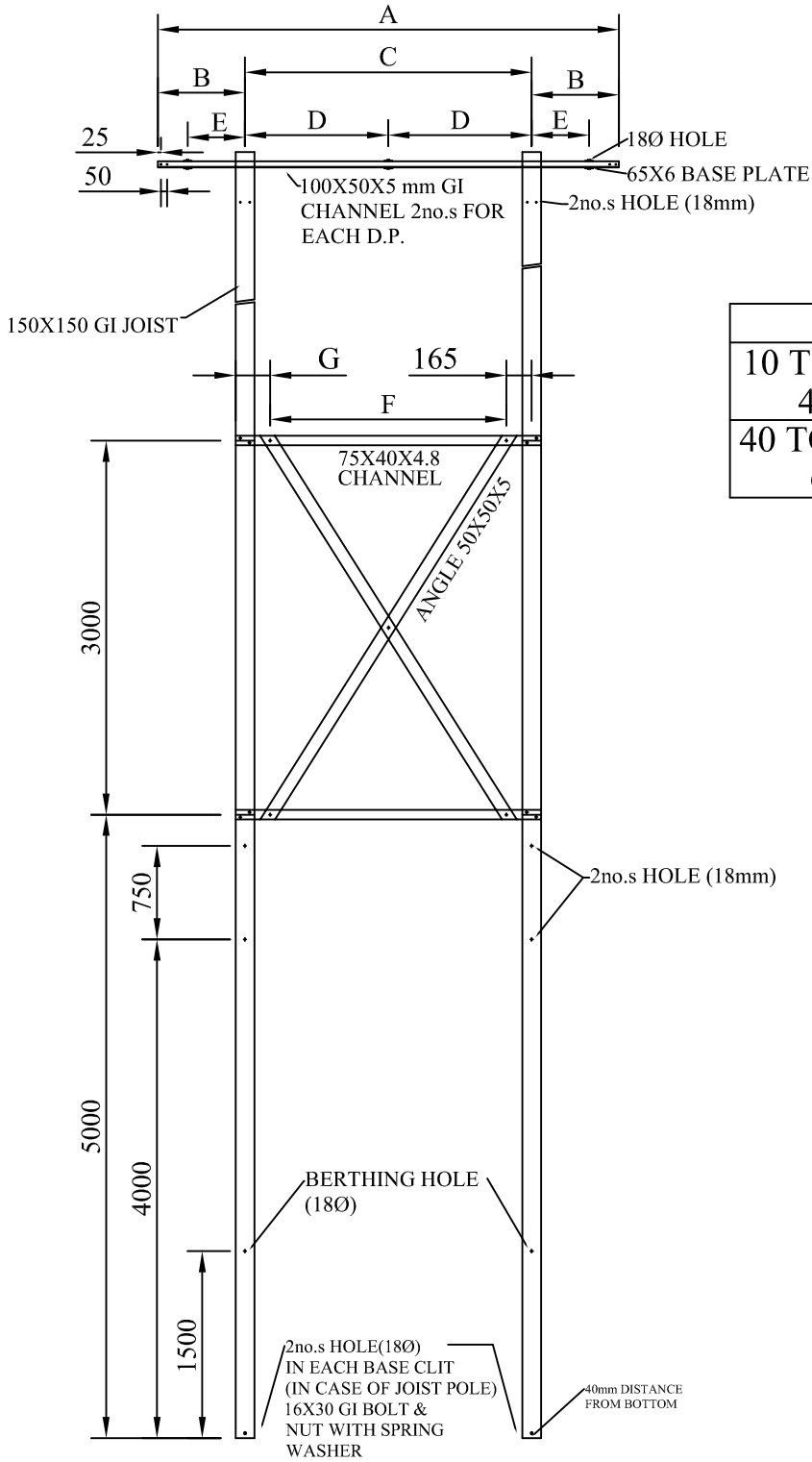

	A	B	C	D	E	F	G
10 TO 40	3700		2300		460		240
		700		1150		1970	
40 TO 60	4200		2500		600		240
		850		1250			

CESU CAPEX





# DP STRUCTURE USING 10000mm, 400kg PSC POLE(150X150X10000mm)

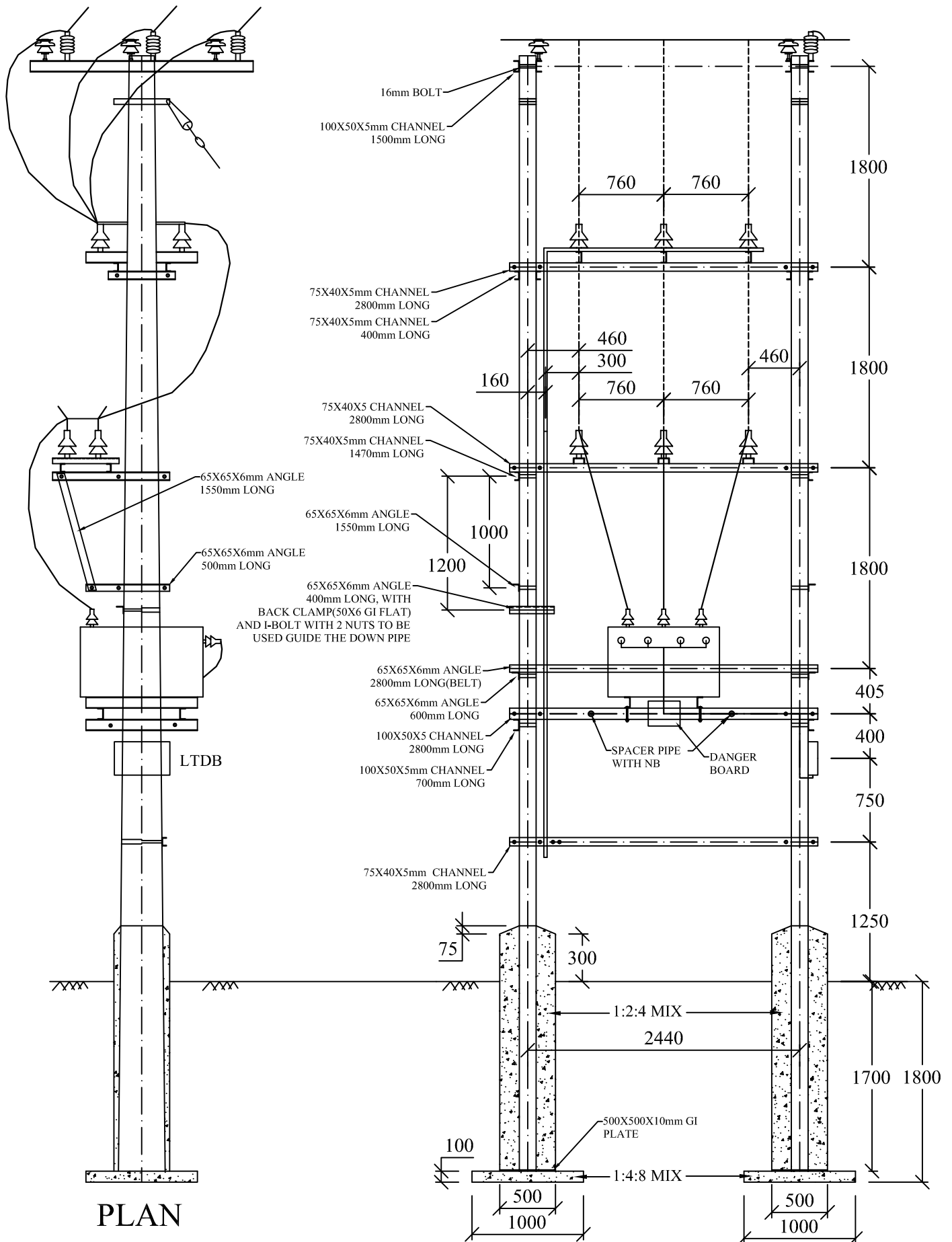

**ELEVATION**



# DP STRUCTURE USING 10000mm, 400kg PSC POLE(150X150X10000mm)

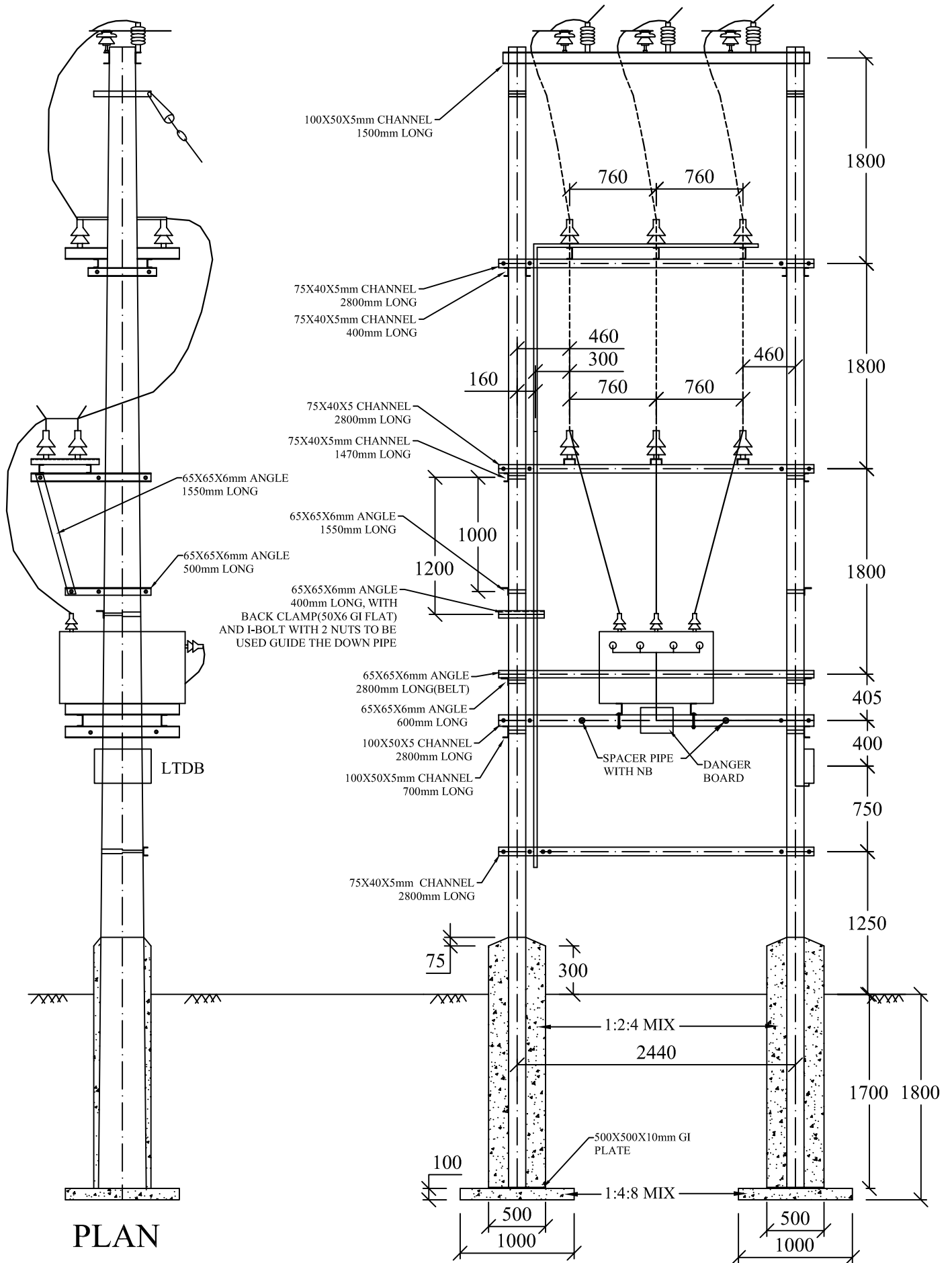

**PLAN**

**ELEVATION**



# DP STRUCTURE USING 10000mm, 400kg PSC POLE(150X150X10000mm)

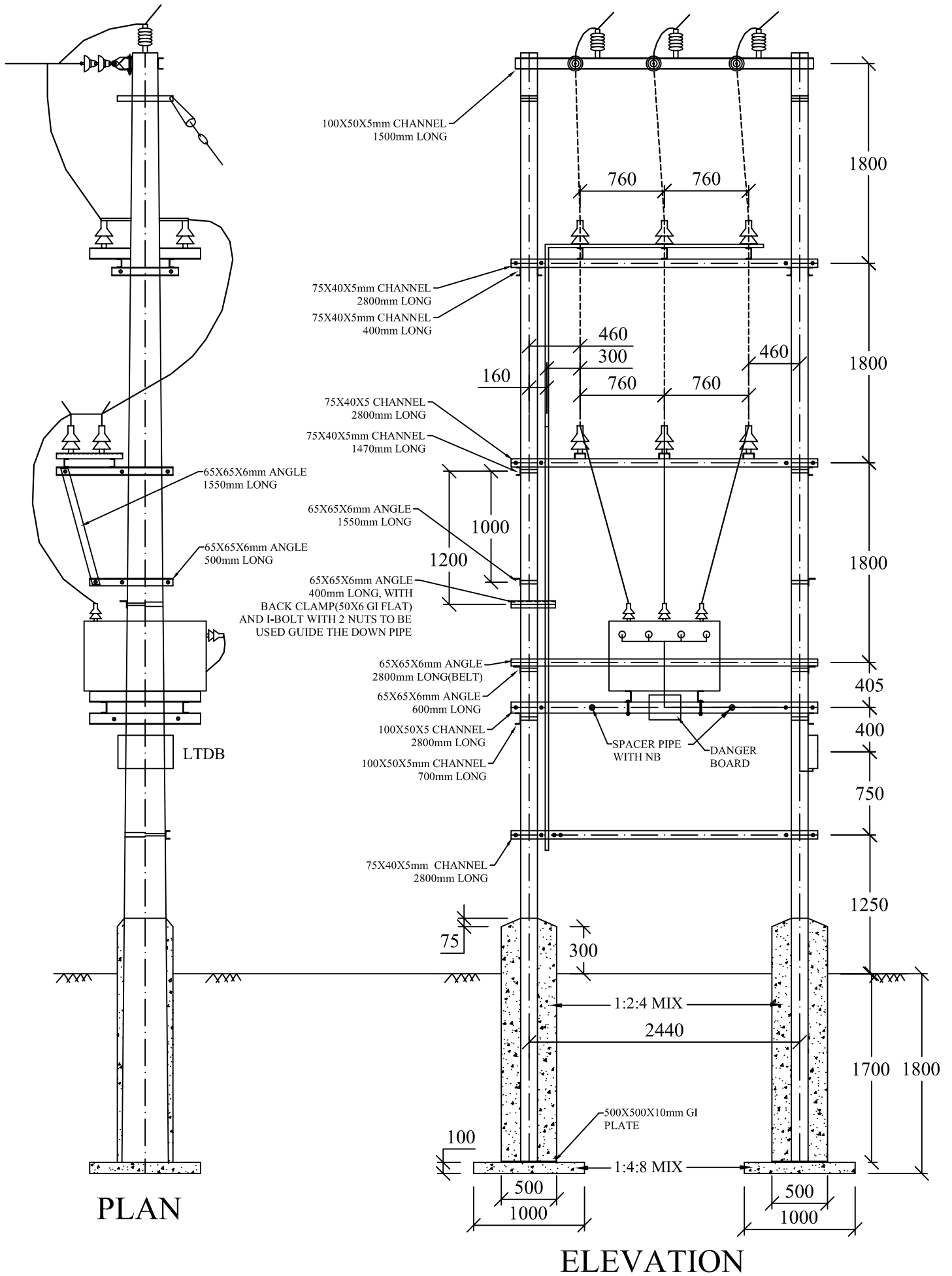





# EARTH MAT LAYING

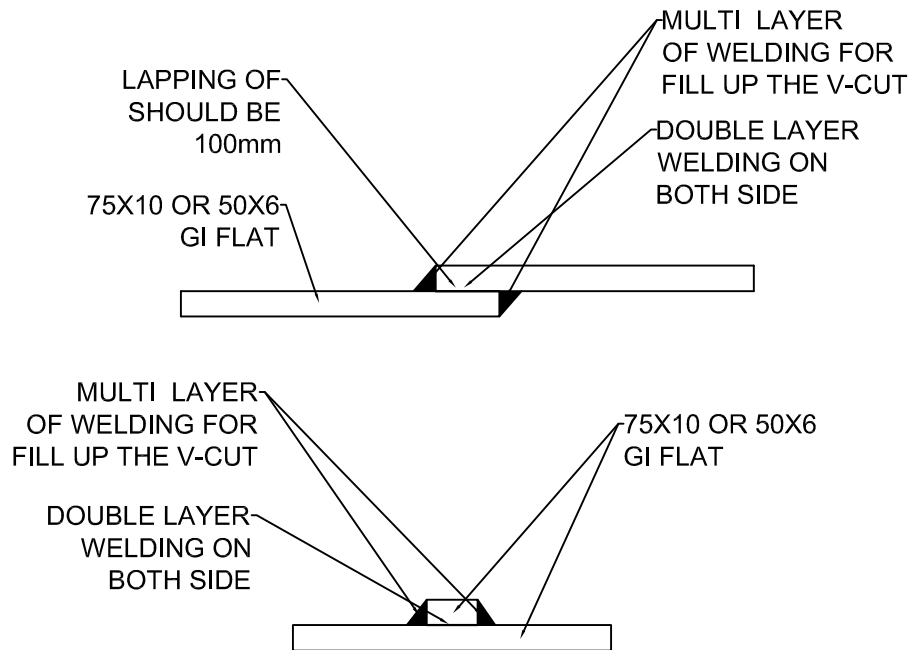

## NOTE:

1. ZINC TO BE REMOVED(THE JOINTING PORTION OF THE FLAT) PRIOR TO WELDING OF JOINT.
2. AFTER REMOVAL OF ZINC THE JOINTING PORTION SHOULD BE RIGIDLY HOLD BY USING "C" CLAMP THEN ONLY THE WELDING WAS SHOULD BE TAKEN UP.
3. THE FLUX SHOULD BE REMOVE BEFORE PUTTING THE SUCCESSIVE LAYERS OF THE WELDING.
4. AFTER COMPLETION OF WELDING WORK THE "C" CLAMP SHOULD BE REMOVED.
5. JUST AFTER COMPLETION OF WELDING WORK TWO LAYER OF ANTICORROSION PAINT SHOULD BE APPLIED IMMEDIATELY.
6. THEN DOUBLE LAYER OF BLACK BITUMINOUS PAINT SHOULD BE APPLIED OVER THE WELDING PORTION.
7. BEFORE BURRING THE FLAT INSIDE THE TRENCH EACH JOINT SHOULD BE COVERED WITH BLACK TAPE.
8. EACH JOINTING PORTION COVERED WITH CONCRETE MIX(1:2:4) ALL AROUND BEFORE FILLING OF SOIL.

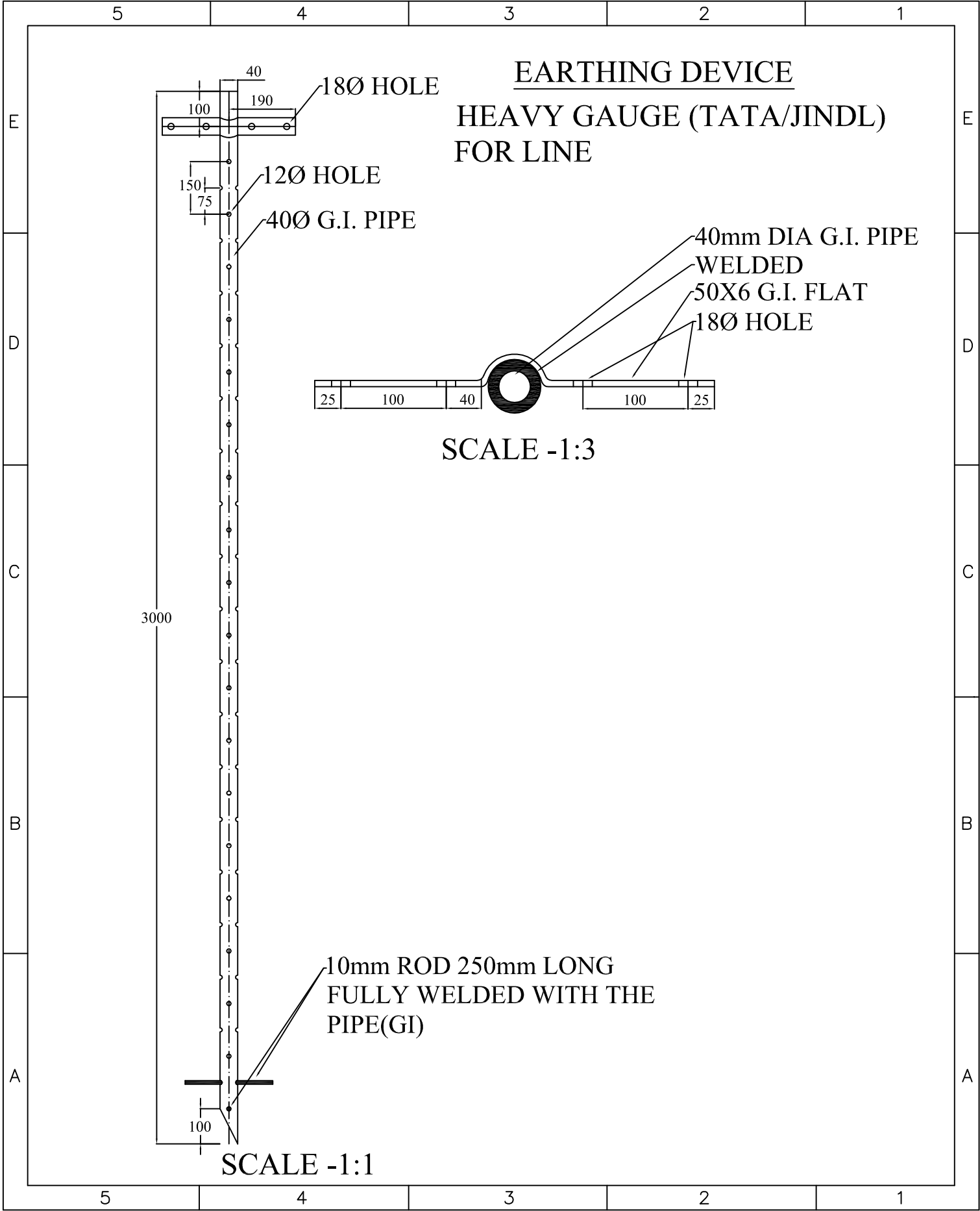

**EARTHING DEVICE**  
**HEAVY GAUGE (TATA/JINDL)**  
**FOR LINE**

40  
 180 HOLE  
 190  
 100  
 120 HOLE  
 150  
 75  
 400 G.I. PIPE

40mm DIA G.I. PIPE  
 WELDED  
 50X6 G.I. FLAT  
 180 HOLE



SCALE -1:3

3000

10mm ROD 250mm LONG  
 FULLY WELDED WITH THE  
 PIPE(GI)

SCALE -1:1

5                      4                      3                      2                      1

E

E

D

D

C

C

B

B

A

A

5                      4                      3                      2                      1

5

4

3

2

1

E

E

D

D

C

C

B

B

A

A

**EARTHING DEVICE**  
**HEAVY GAUGE (TATA/GINDL)**  
**FOR SUB-STATION**

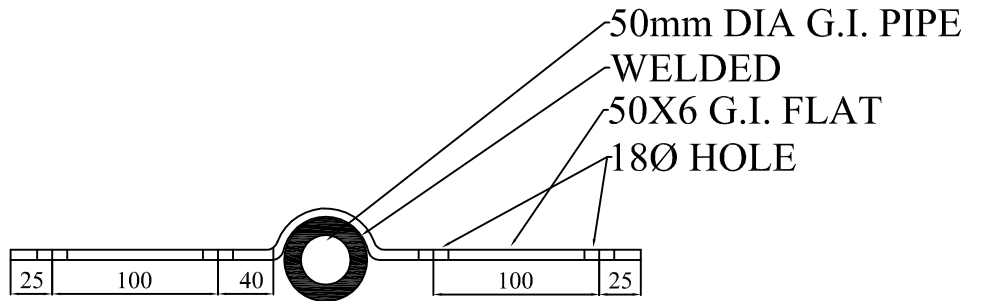
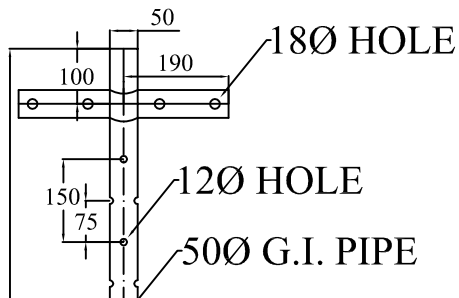

SCALE -1:3

3000

SCALE -1:1

**CESU CAPEX**

5

4

3

2

1

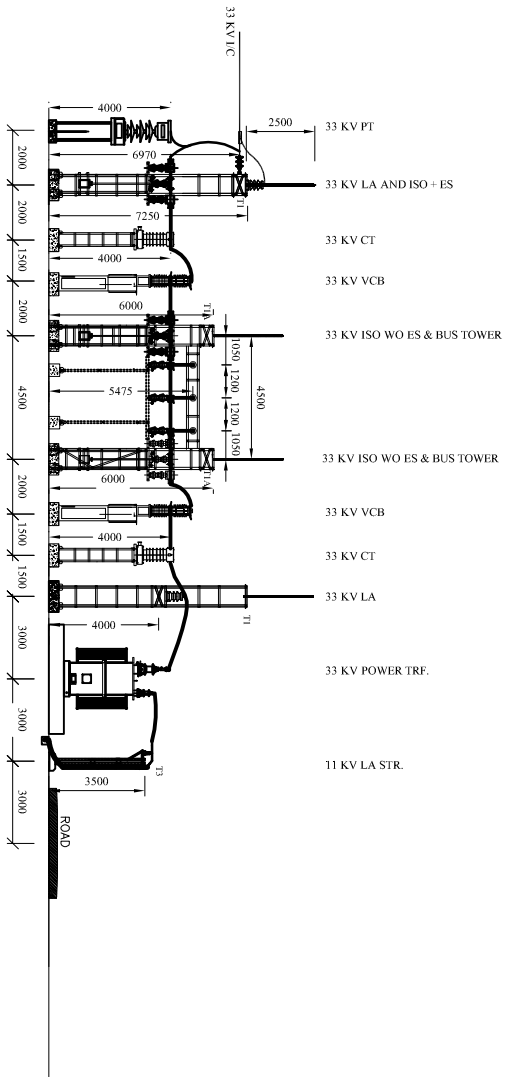

**SECTION A-A**

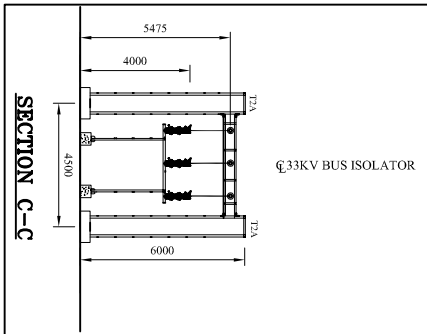

**SECTION C-C**

33KV BUS ISOLATOR

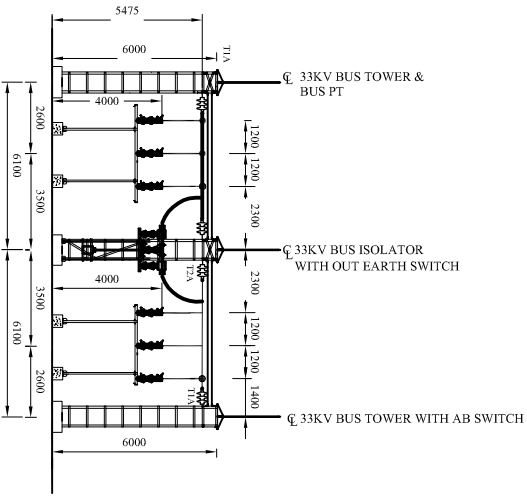

**SECTION B-B**

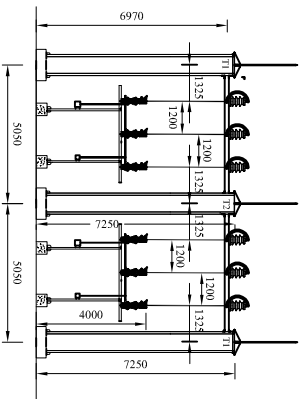

**SECTION D-D**

**NOTE:**  
 1) ALL DIMENSIONS ARE IN MM.  
 2) SPICES SHOULD BE ZSP AND 2500 MM LONG.

**CLEARANCES:-**

1. 33KV PHASE TO PHASE = 1500
2. 11KV PHASE TO PHASE = 650
3. 33KV GROUND CLEARANCE = 4000
4. 11KV GROUND CLEARANCE = 1300
5. 33KV PHASE TO EARTH PART = 610
6. 11KV PHASE TO EARTH PART = 310
7. SECTIONAL CLEARANCE = 5000

**Outdoor Primary S/S**  
**SECTION A-A**

**CESU CAPEX**

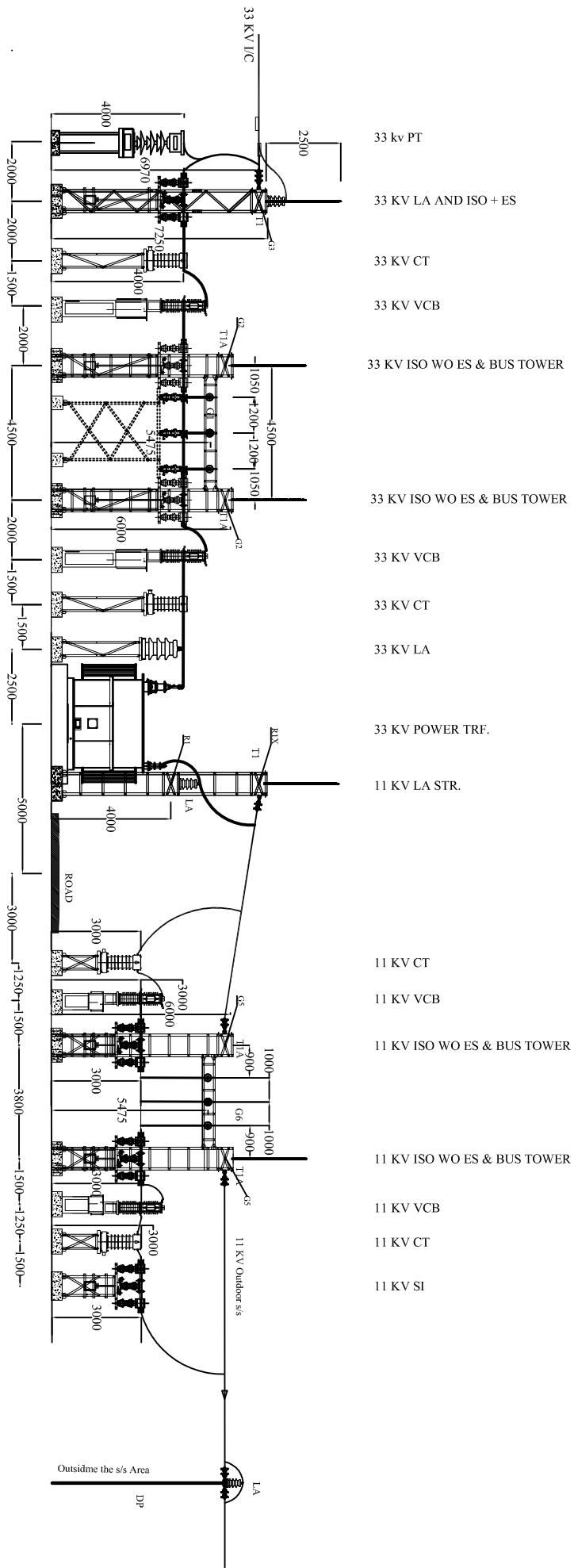

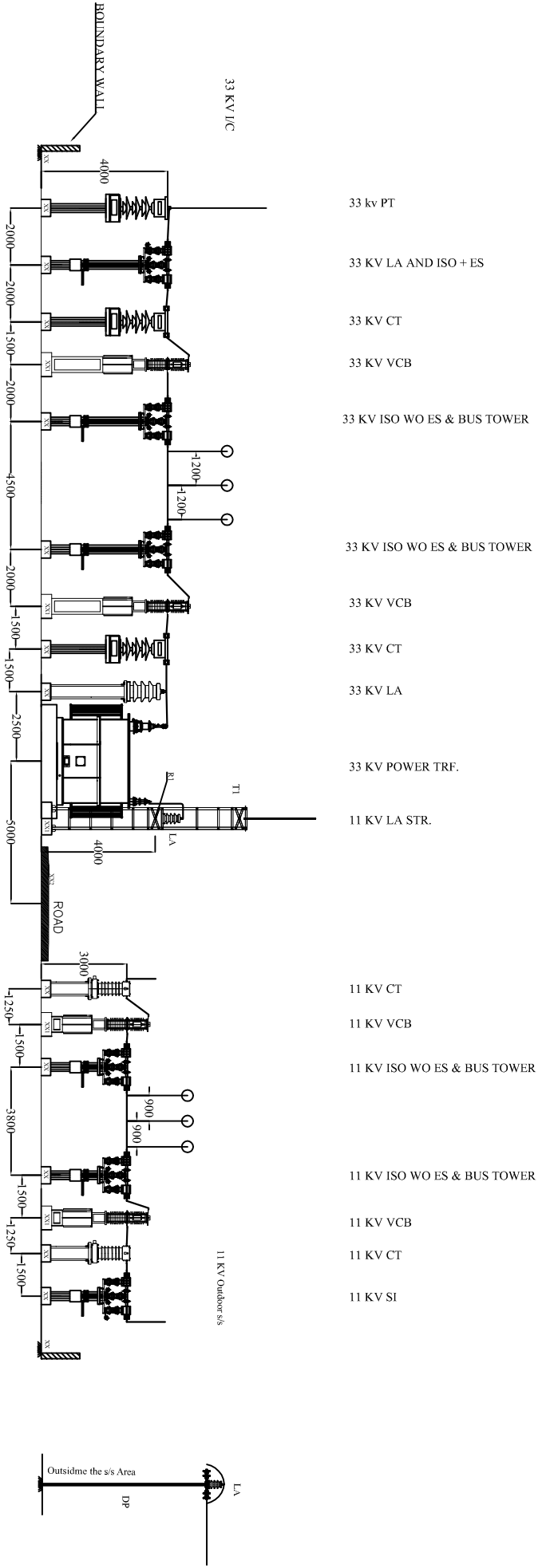

**Outdoor Type Primary S/S**  
**SHOWING THE EQUIPMENT POSITION IN LONGITUDINAL VIEW**

- TOP OF THE PLINTH SHOULD BE 325mm ABOVE THE METAL.
  - THE TOP HEIGHT OF THE ROAD SHOULD BE 200mm ABOVE METAL - .XX2
  - CONCRETE LEVEL OF CB TO BE DECIDED AS PER THE STRUCTURE AVAILABLE FOR MAINTAINING 4000mm IN 33kv, 3000mm MINIMUM IN 11kv - .XX1
  - TOP OF FOUNDATION LEVEL OF COLUMN EQUIPMENT (EXCEPT CB), CABLE TRENCH, DRAIN(150mm ABOVE METAL) - .XX
- ↓
- METAL FILLING (100MM THICKNESS) BY USING 25X40mm IIG CROSSER BROKEN METAL
- PCC 1:4:8 USING 40mm SIZE CROSSER BROKEN IIG METAL (75mm)
- 150
- 75

**CESU CAPEX**

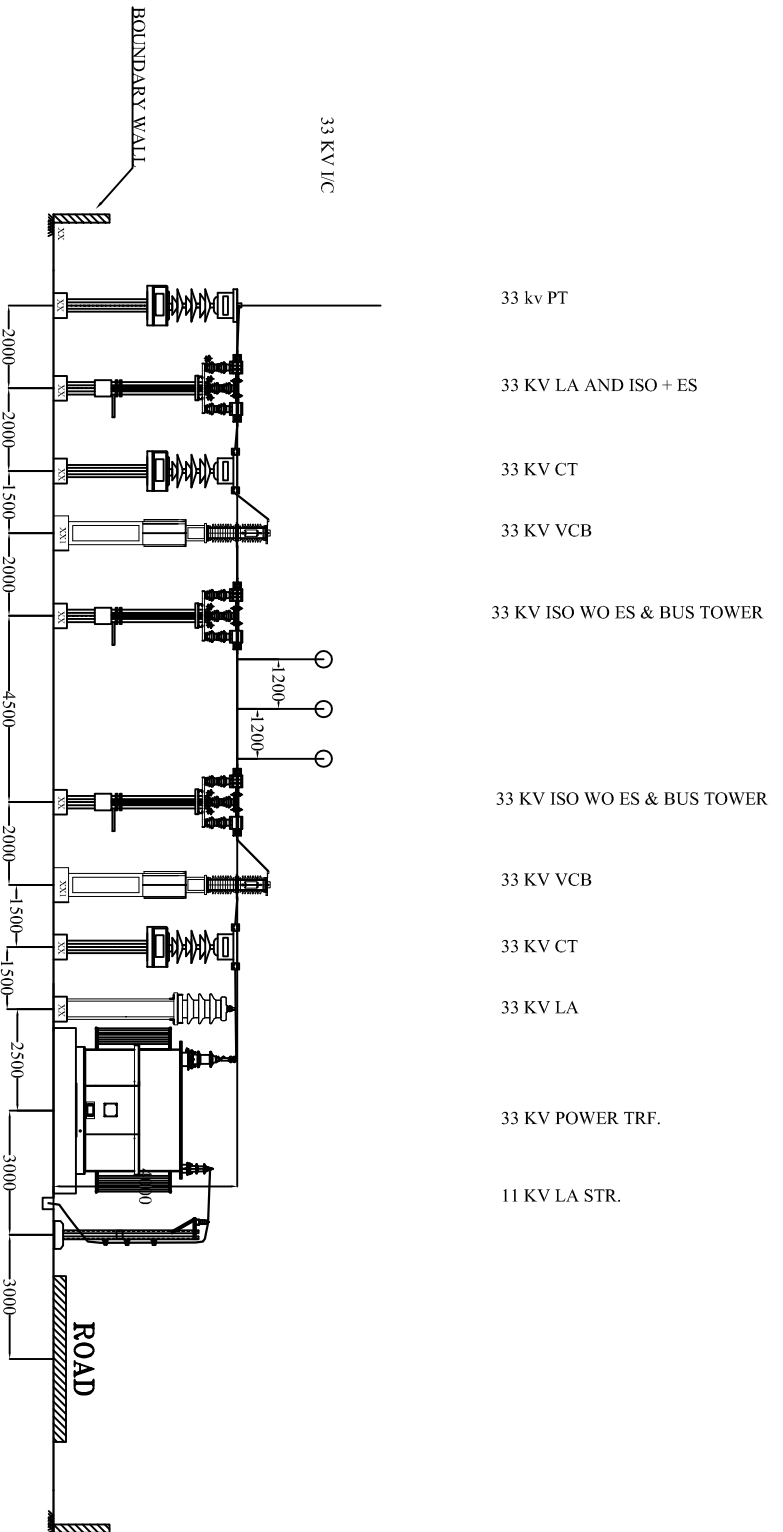

**INDOOR TYPE Primary S/S**  
**SHOWING THE EQUIPMENT POSITION IN LONGITUDINAL VIEW**

TOP OF THE PLINTH SHOULD BE 325mm ABOVE THE METAL.

THE TOP HEIGHT OF THE ROAD SHOULD BE 200mm ABOVE METAL - XX2

CONCRETE LEVEL OF CB TO DECIDED AS PER THE STRUCTURE AVAILABLE FOR MAINTAINING 4000mm IN 33kv, 3000mm MINIMUM IN 11kv - XXI

TOP OF FOUNDATION LAVEL OF COLUMN EQUIPMENT (EXCEPT CB), CABLE TRENCH, DRAIN,(150mm ABOVE METAL) - XX



METAL FILLING (100MM THICKNESS) BY USING 25X40mm HG CROSSER BROKEN METAL  
 PCC 1:4:8 USING 40mm SIZE CROSSER BROKEN HG METAL (75mm) 75

**CESU CAPEX**



# FOUNDATION BOLT ARRANGEMENT FOR INDOOR

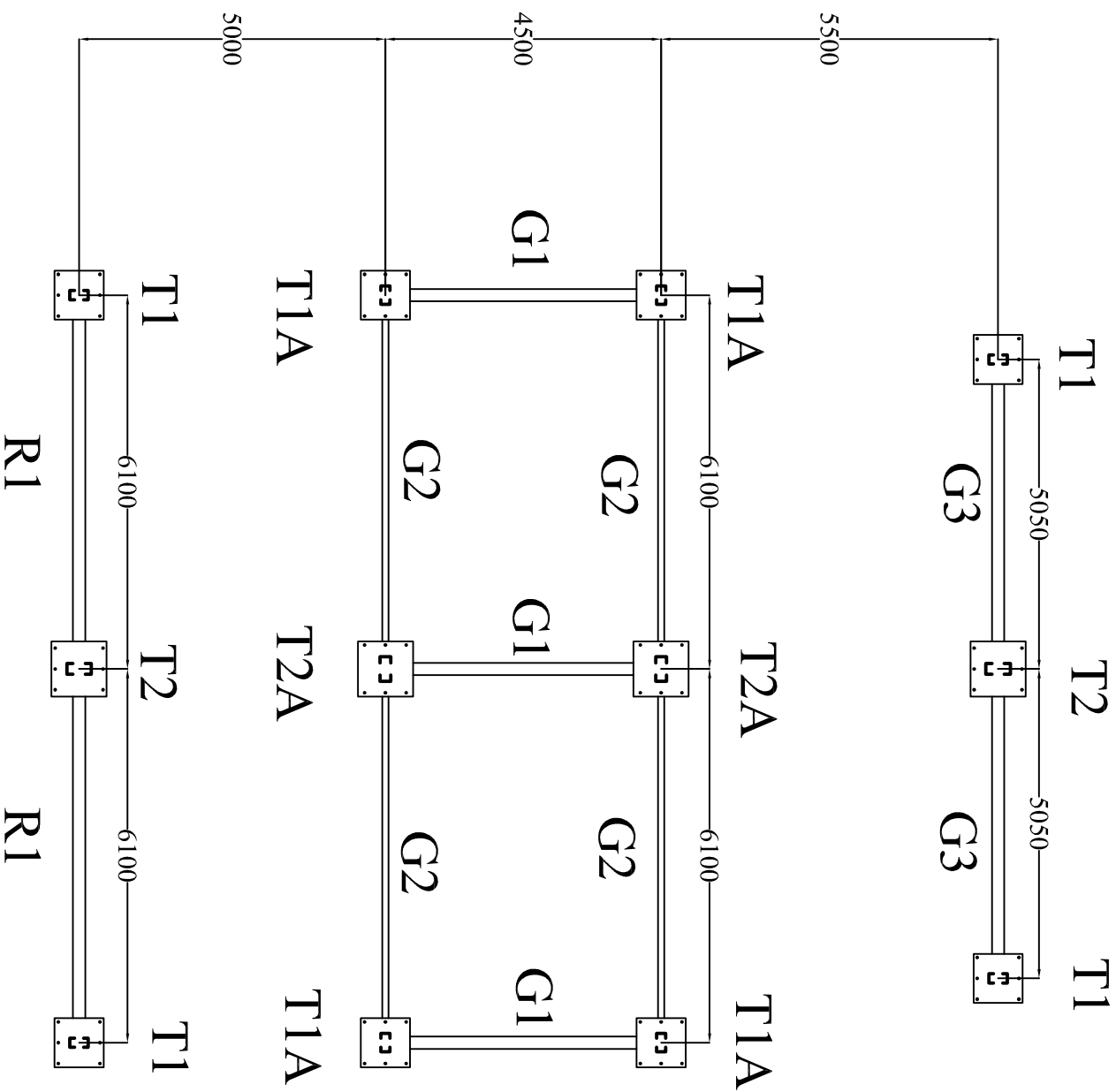

ALL THE BOLT HOLES 34mm.

CESU CAPEX

# FOUNDATION BOLT ARRANGEMENT FOR OUTDOOR

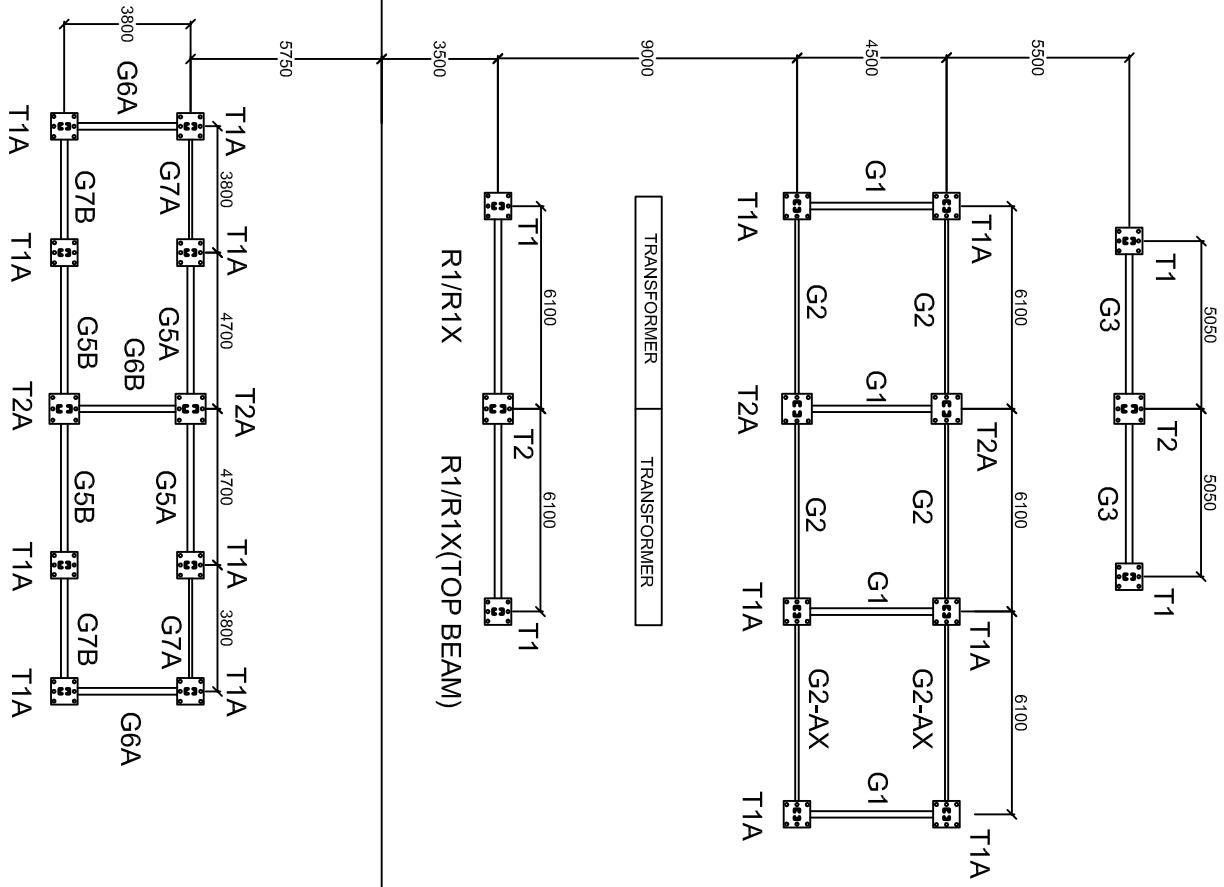

ALL THE BOLT HOLES 34mm.

# INDOOR S/S

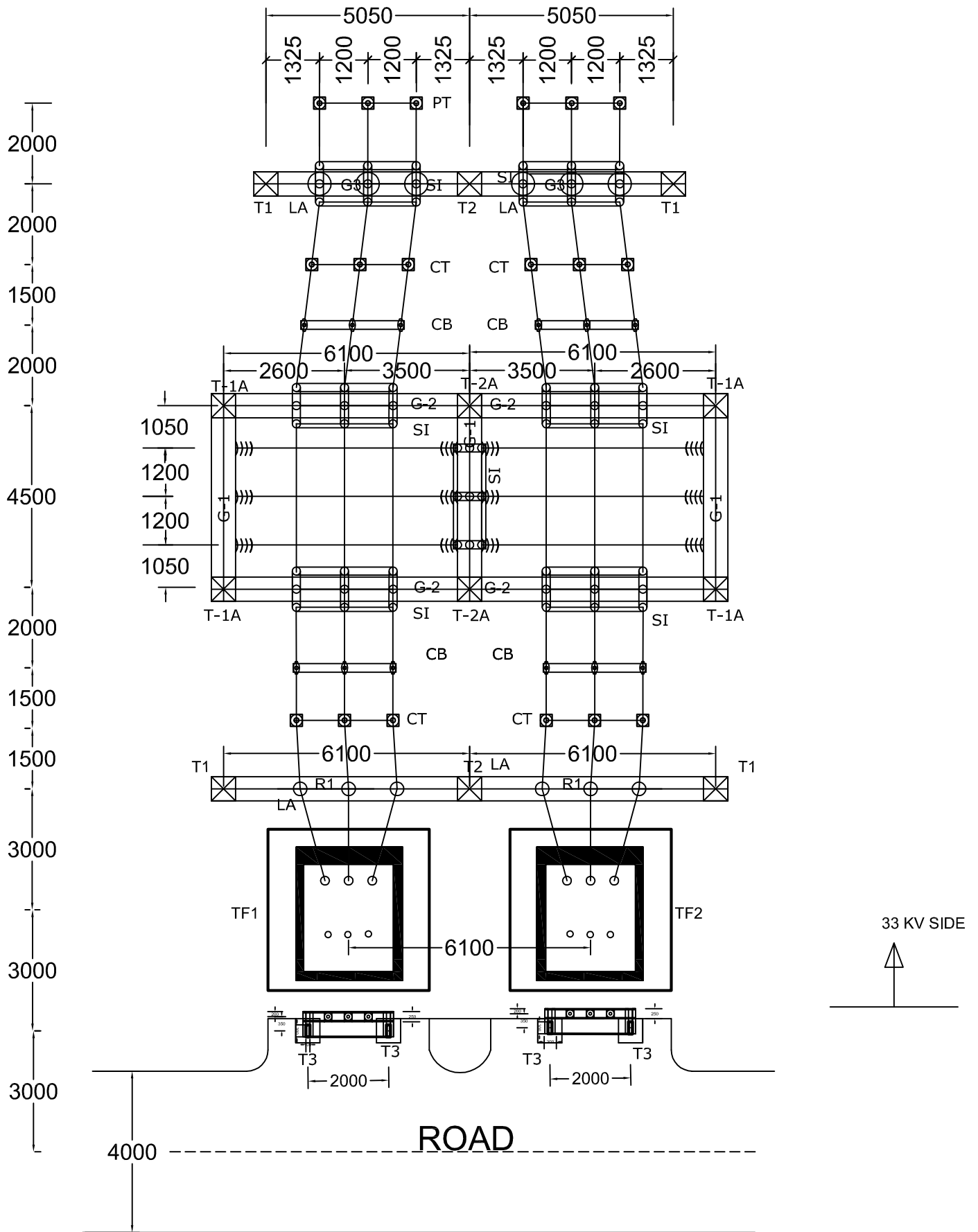

CESU CAPEX

11.02.2013 NEW MODIFY

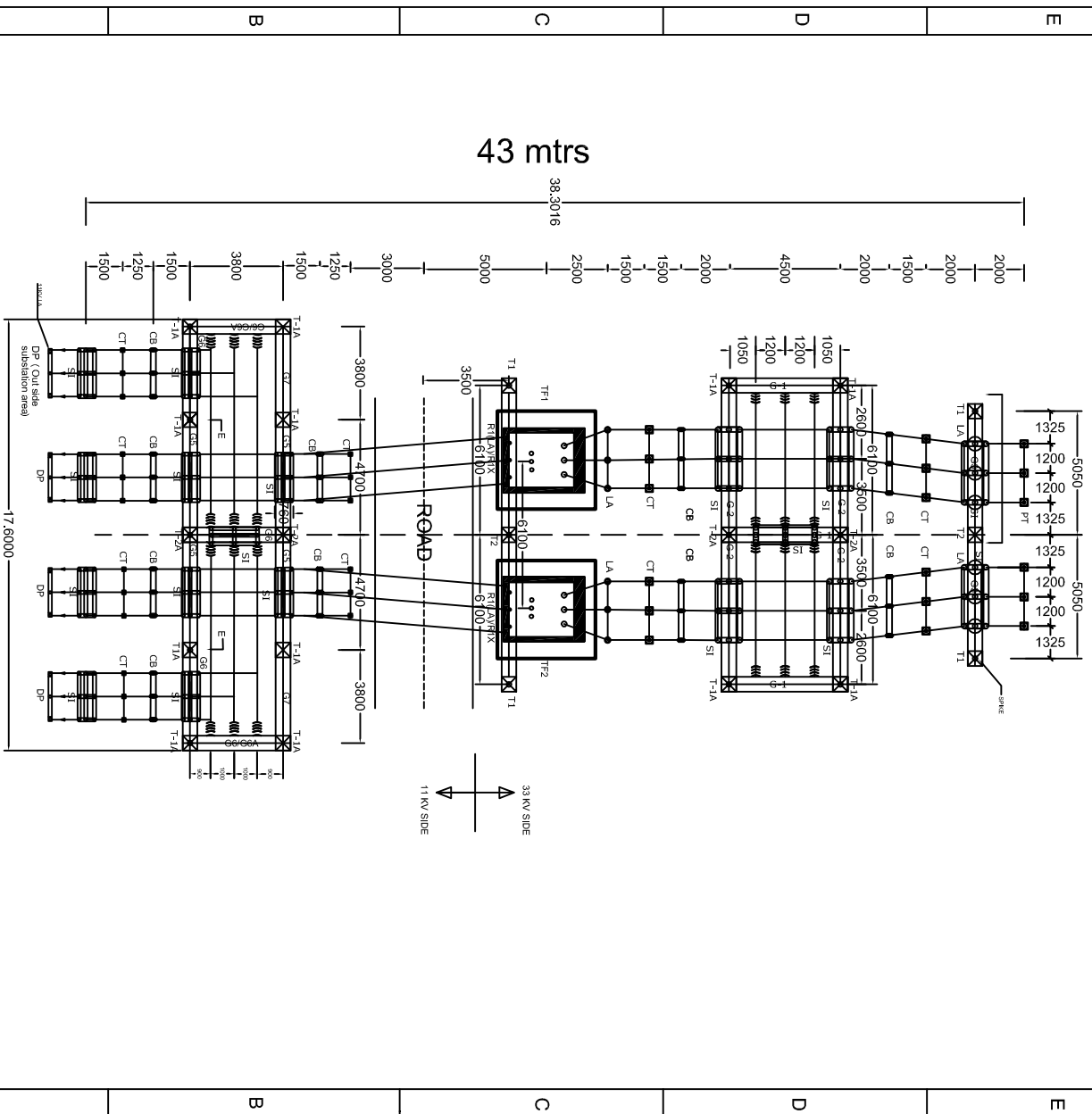

43 mtrs

30 mtrs

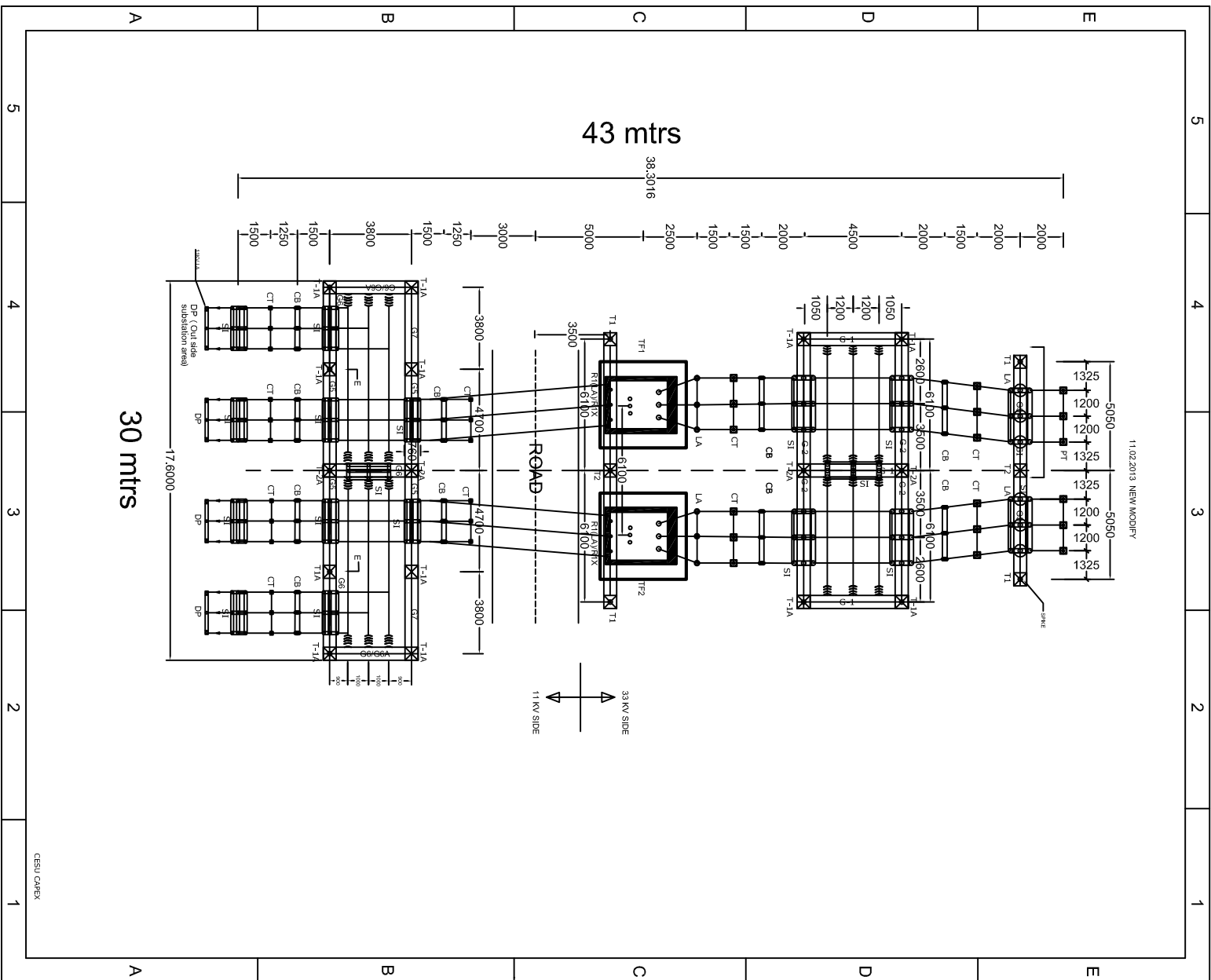

# PG CLAMP

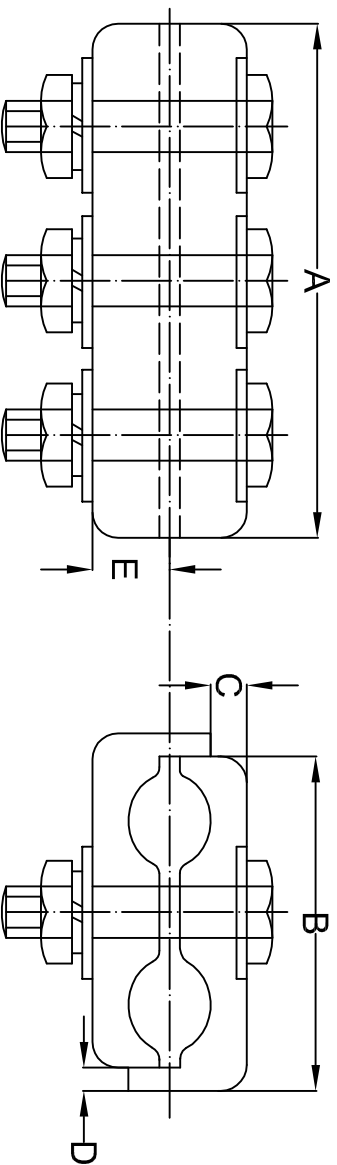

## TECHNICAL DATA:

1. ALUMINUM ALLOY - LM-6
2. BOLT&NUT IS -1367(HDG)
3. SPRING & FLAT WASHER - ELECTRO GALVANIZED
4. TOLERANCE +5%
5. ALL DIMENSION ARE IN MM.

CONDUCTOR NAME	NOMINAL AREA(mm <sup>2</sup> )	CONDUCTOR DIA	DIMENSION IN mm					NO. OF BOLTS
			A	B	C	D	E	
DOG-DOG	100	12.78 -12.78	100	65	10	4.5	15	3, M12 (HDG)
RACCOON-RACCOON	80	11.43-11.43	100	58	10	4.5	15	3, M12(HDG)
RABBIT-RABBIT	55	9.45-9.45	95	54	10	4.5	13	3,M12(HDG)
ZEBRA-ZEBRA	420	28.62-28.62	150	102	15	5	18	3,M16(HDG)
ZEBRA-PANTHER	420-230	28.62-19.70	150	102	15	5	18	3,M16(HDG)

# SCHNEIDER MAKE 33kv AND 11kv CB FOUNDATION NOT SHOWING RODS

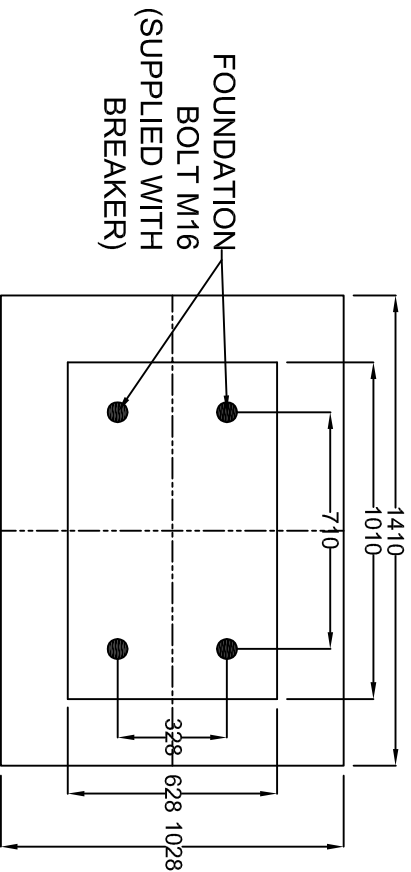
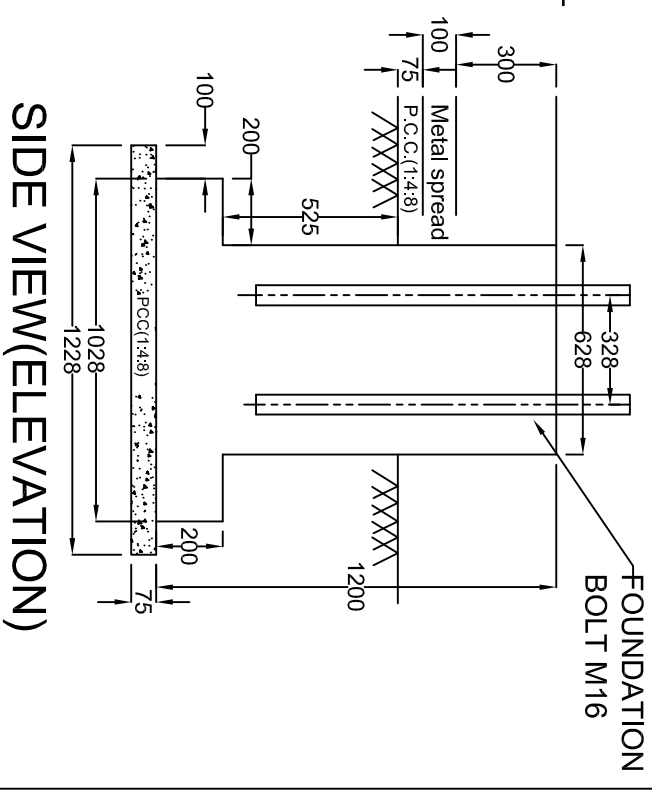
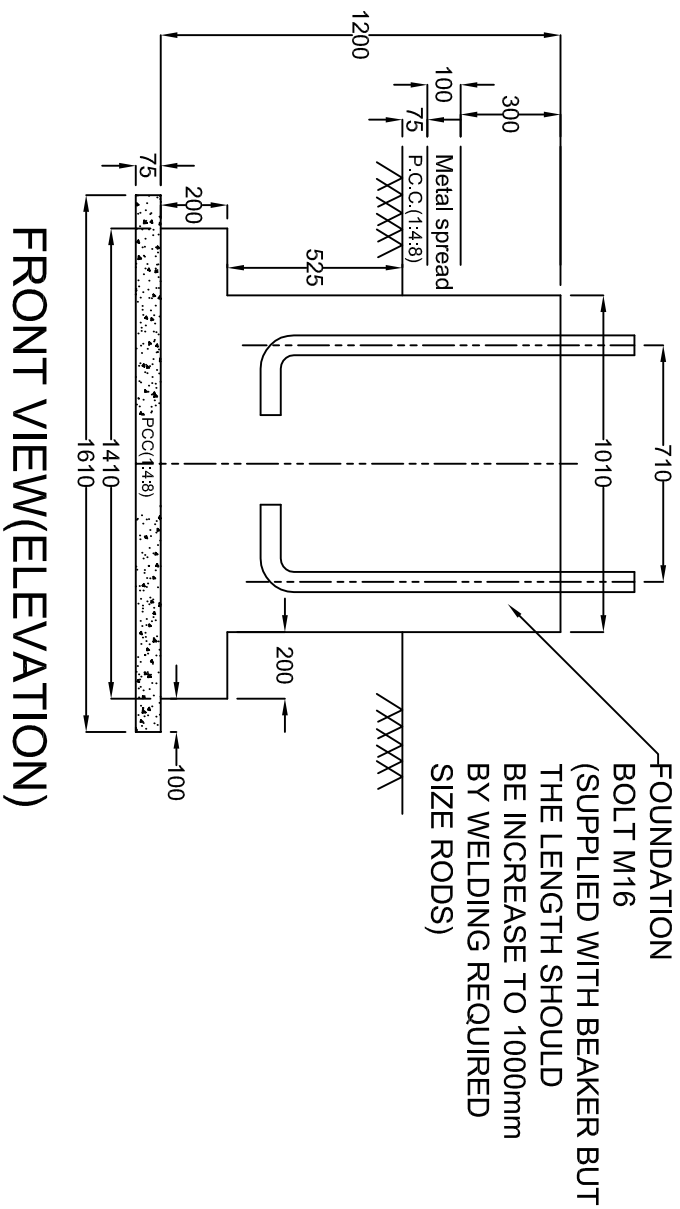

# SCHNEIDER MAKE 33kv AND 11kv CB FOUNDATION

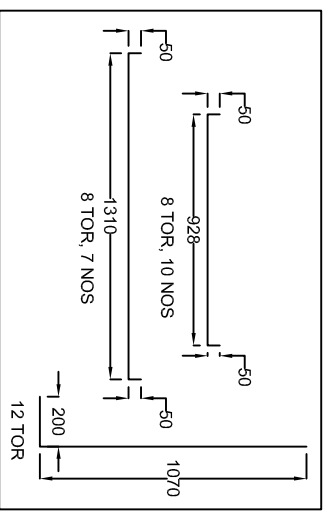
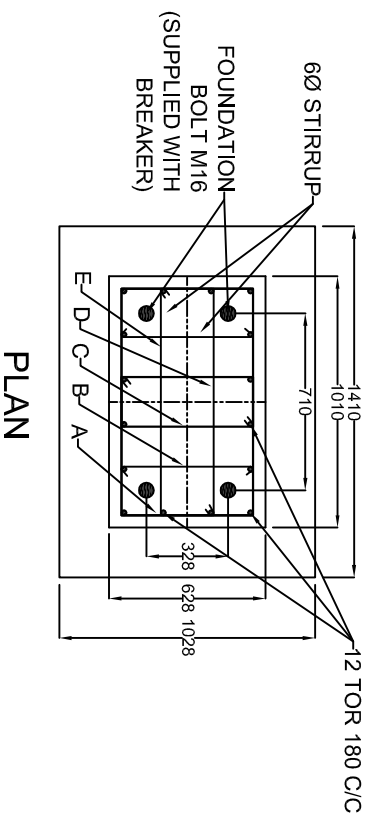
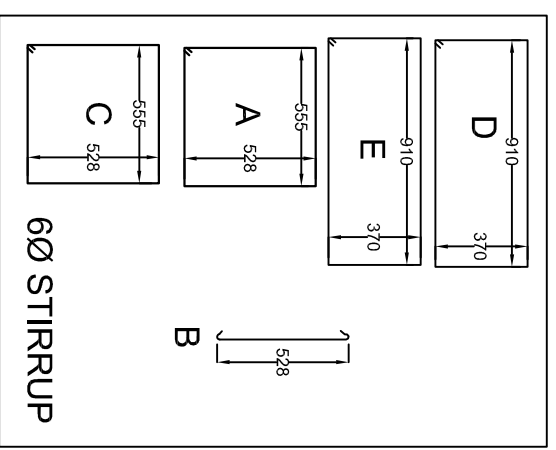
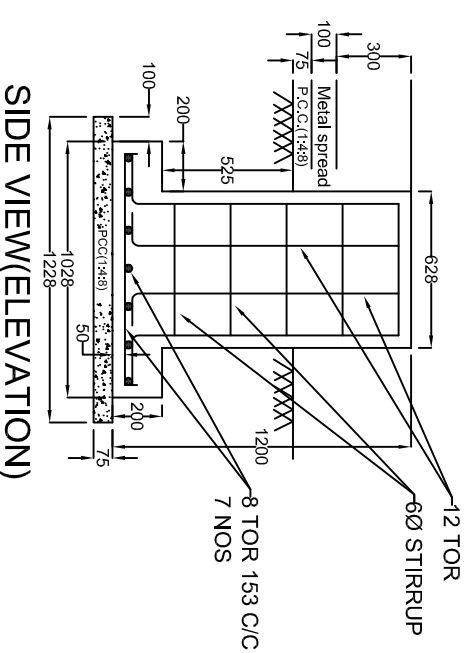
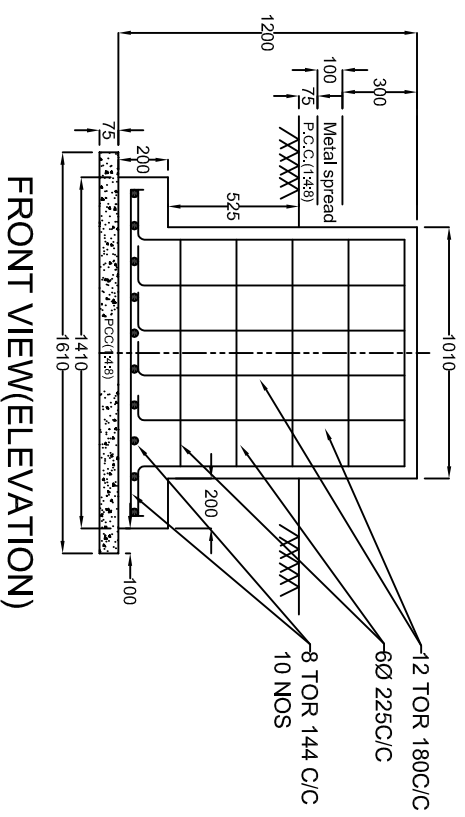

# SCHEMATIC DIAGRAM OF NEW 33/11 kv PRIMARY SUB-STATION

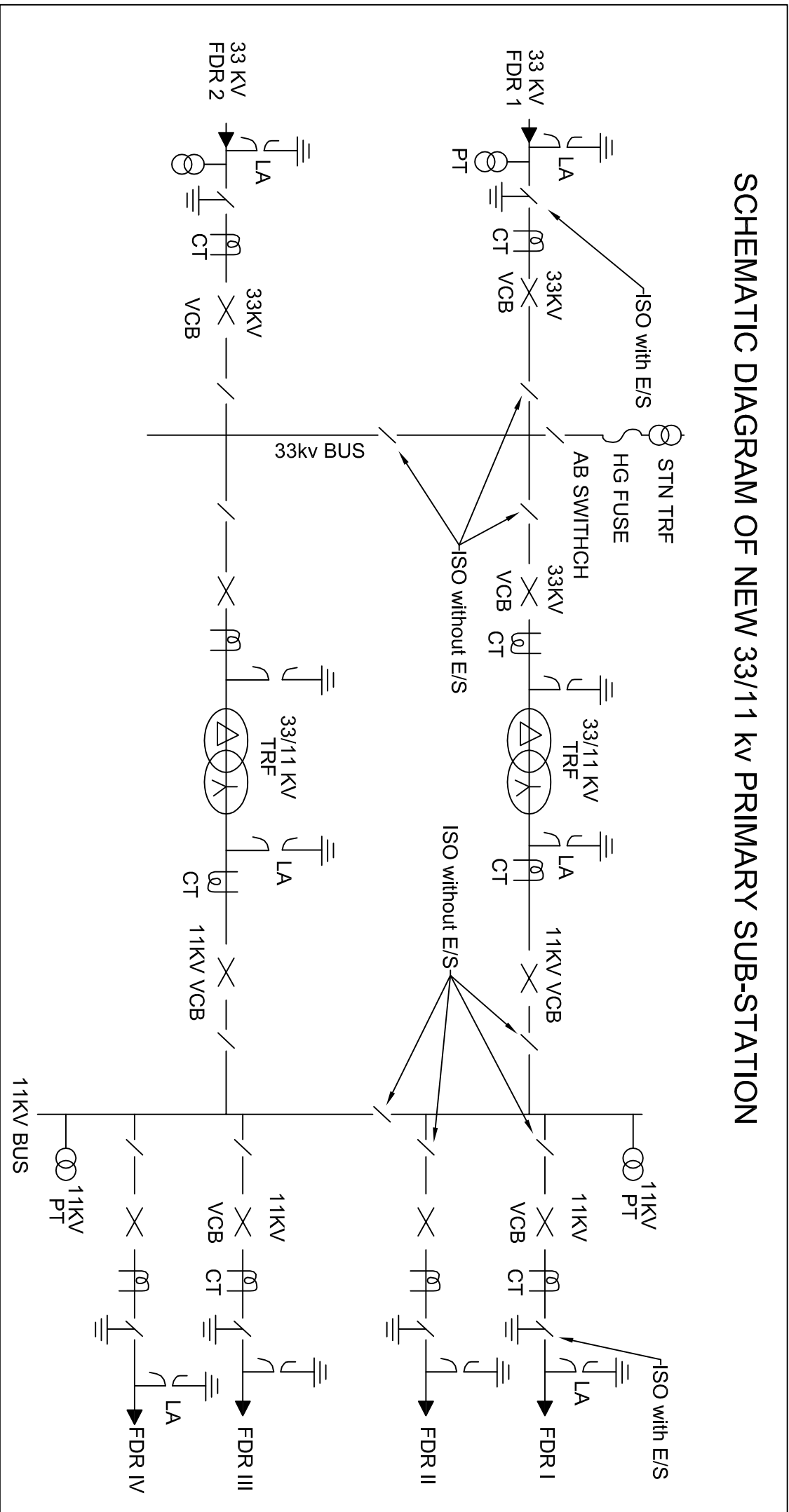



# T-CLAMP

ALL EDGES SHOULD  
MADE OVAL SHAPE

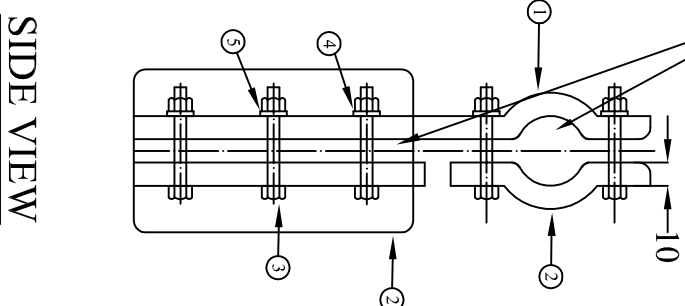
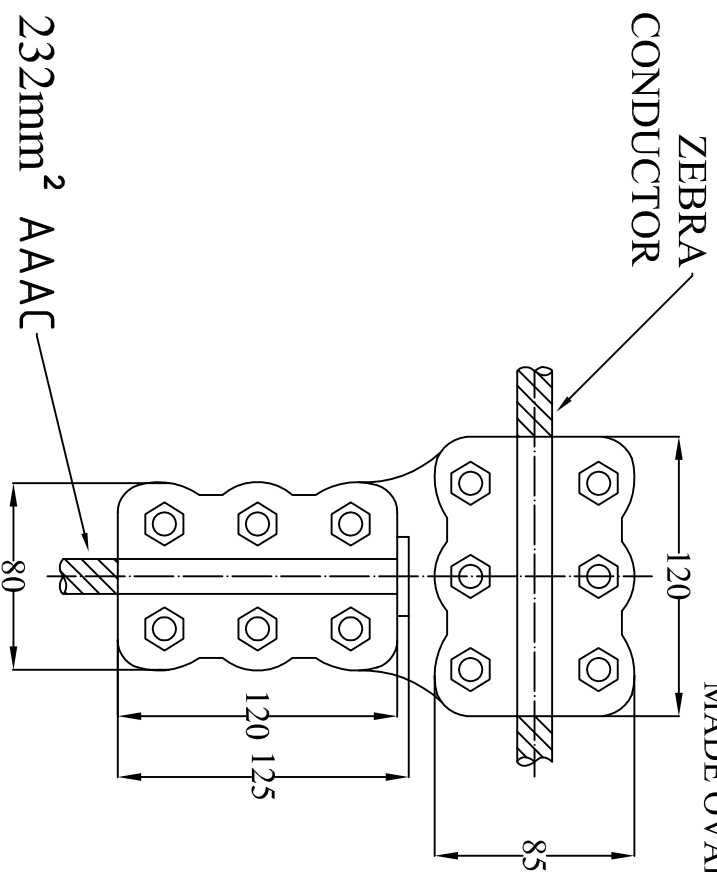

TECHNICAL DATA:  
 1. CLAMP AS PER IS:5561  
 2. ALL FERROUS PARTS ARE HOT DIP GALVANIZED  
 CONFORMING TO IS:2633& SPRING WASHER ARE  
 ELECTRO GALVANIZED CONFORMING TO IS:1573  
 SERVICE COND. III  
 3. GENERAL TOLERANCE  $\pm 5\%$   
 4. MIN. THICKNESS 10mm OF CURRENT CARRYING  
 PART.

## BILL OF MATERIALS

SL NO.	DESCRIPTION	MATERIAL	GRADE	SURFACE TREATMENT	QTY
1	CLAMP	ALUMINUM ALLOY	LM-6;IS:617	---	1 SET
2	KEEPER	ALUMINUM ALLOY	LM-6;IS:617	---	1 SET
3	M12 NUT & BOLT	MS	GR 5.0 & 5.6, IS:1367	H.D.G.	12 SET
4	M12 FLAT WASHER	MS	IS:2062	H.D.G.	12 NOS
5	M12 SPRING WASHER	SPRING STEEL	IS:4072	E.G.	12 NOS

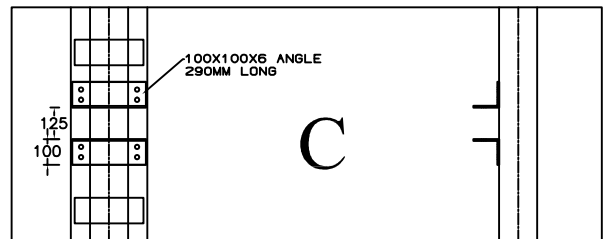
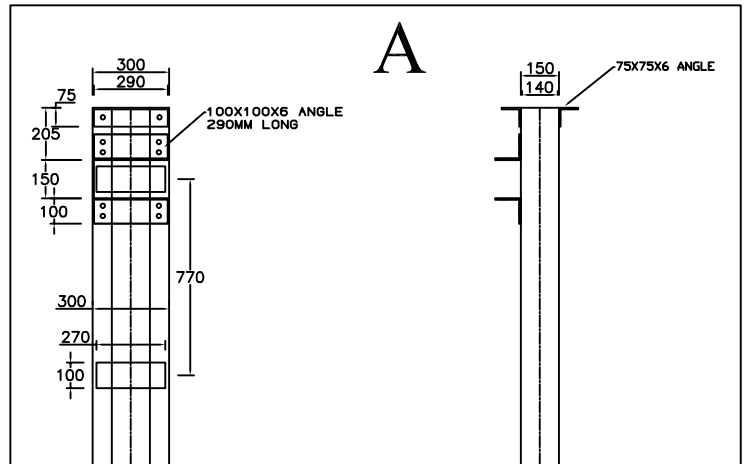
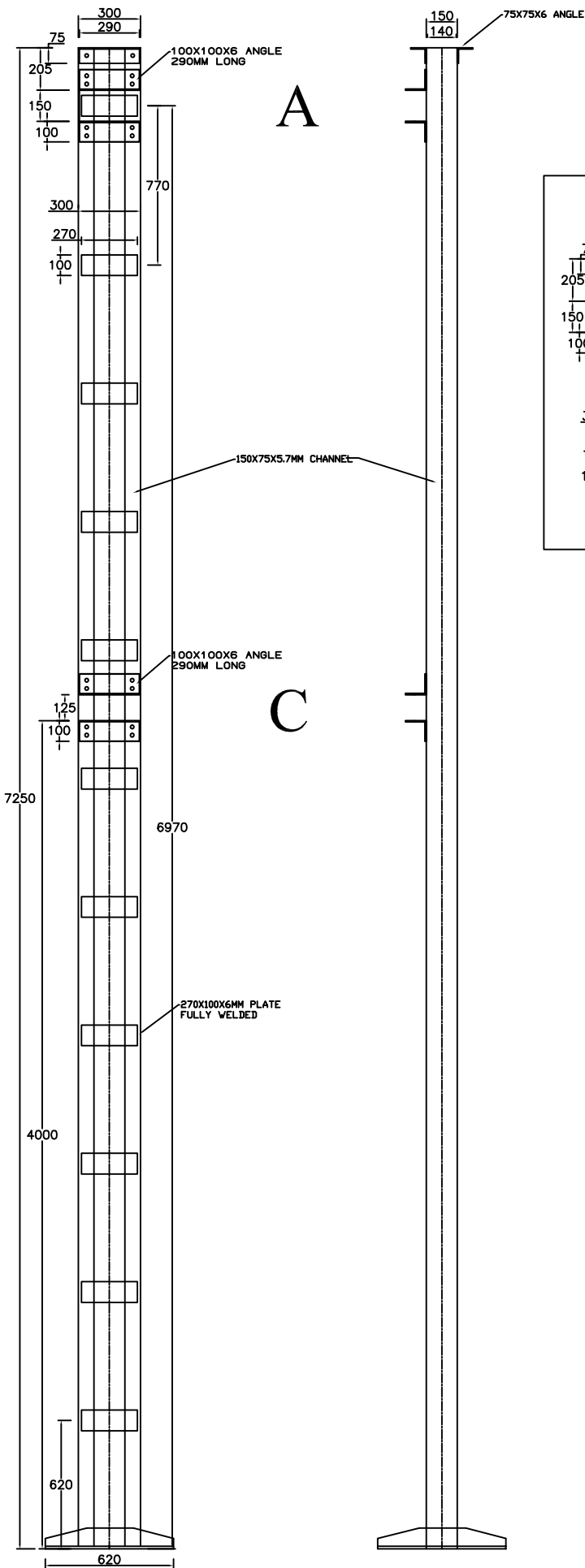

T1 COLUMN WITH BEAM ARRANGEMENT

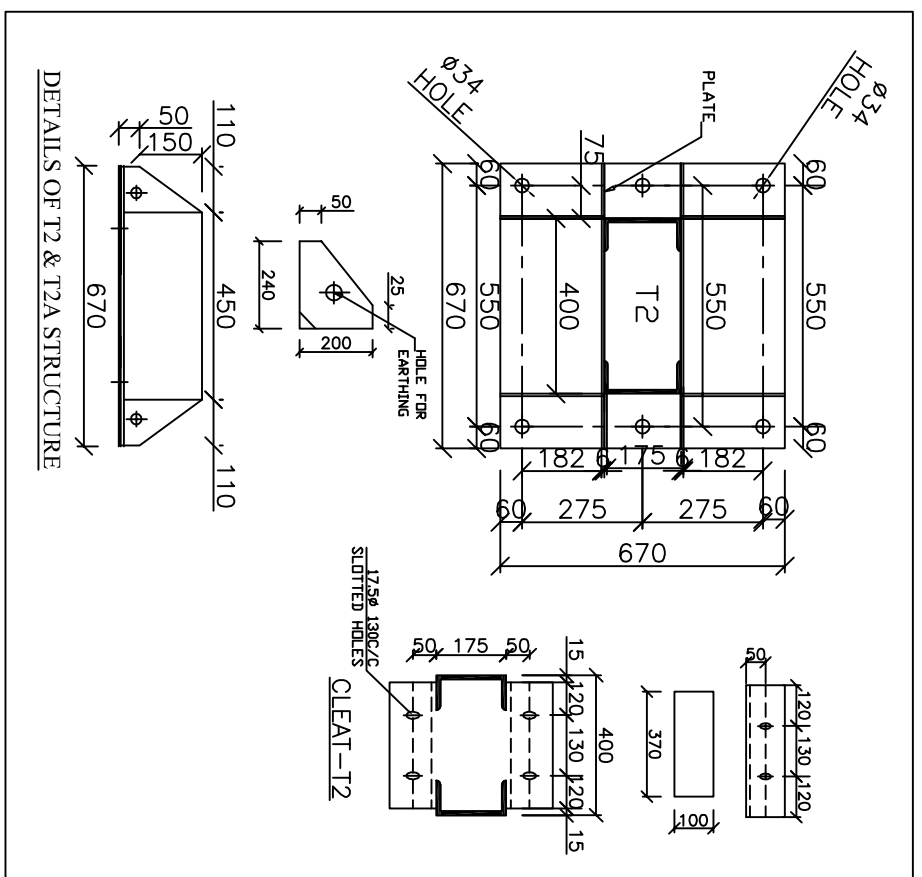
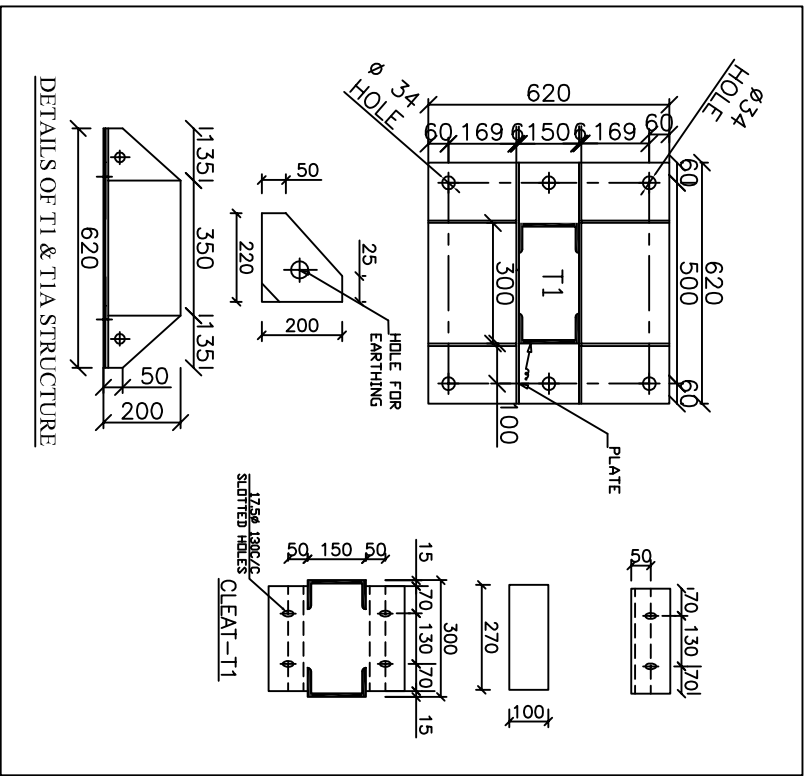

BILL OF MATERIAL								
ERECTION MARKS	DESCRIPTION	A	B	C	TOTAL B+C	D	E	F
1	T1/T2	205	6970	280	7250	150	125	4000
2	T1A/T2A	450	5475	525	6000	150		
3	FOUNDATION BOLT	T1	T2	T1A	T2A	T3		
	a. 32x1400	0	6 NOS	0	6 NOS	0		
	b. 32x1000	6 NOS	0	6 NOS	0	0		
	c. 25x750					4 nos		

CESU CAPEX

# A

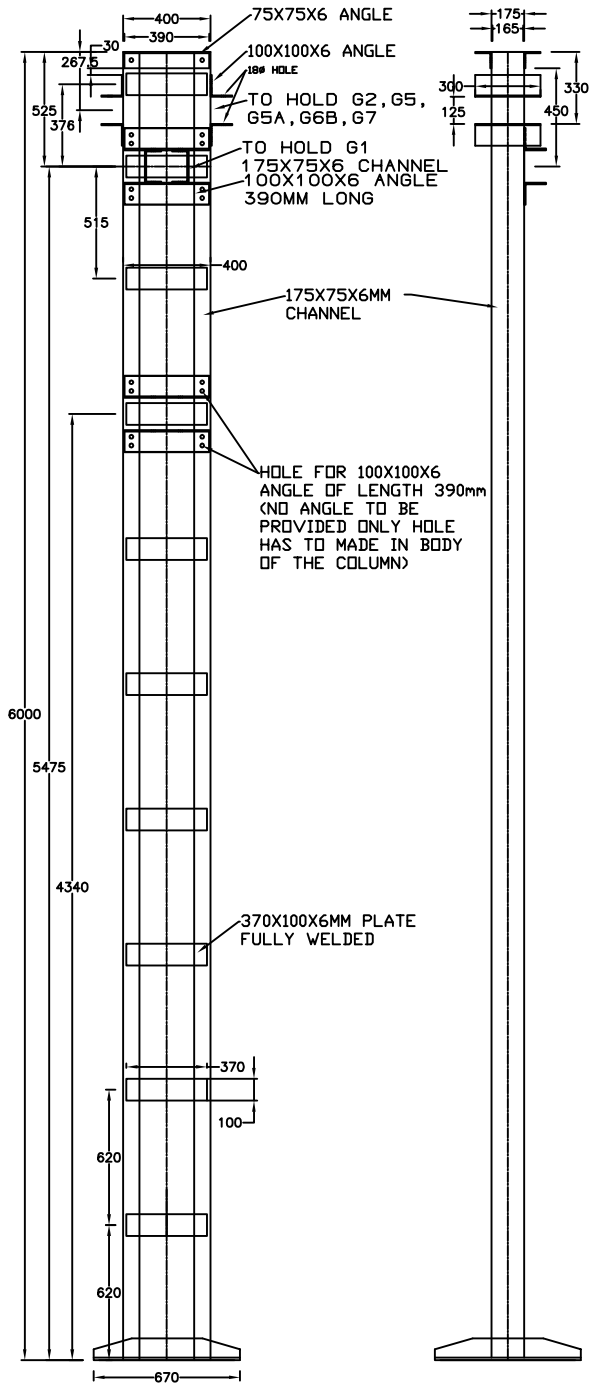

T2A COLUMN WITH BEAM ARRANGEMENT

# B

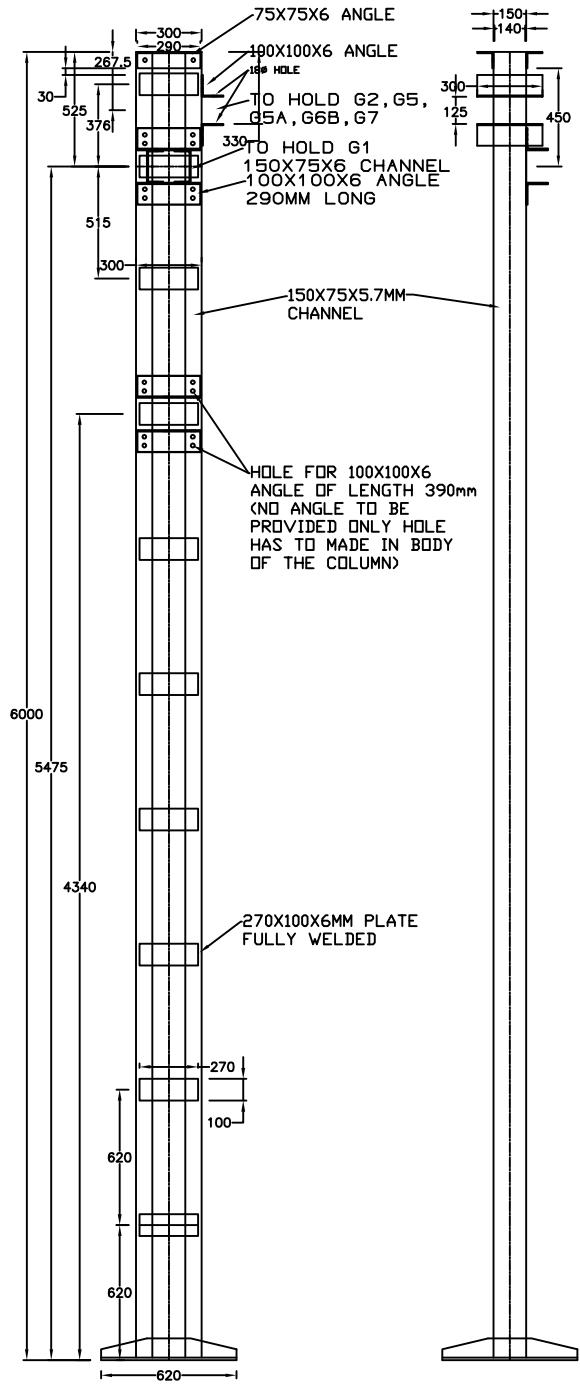

T1A COLUMN WITH BEAM ARRANGEMENT

# T2A COLUMN

# A

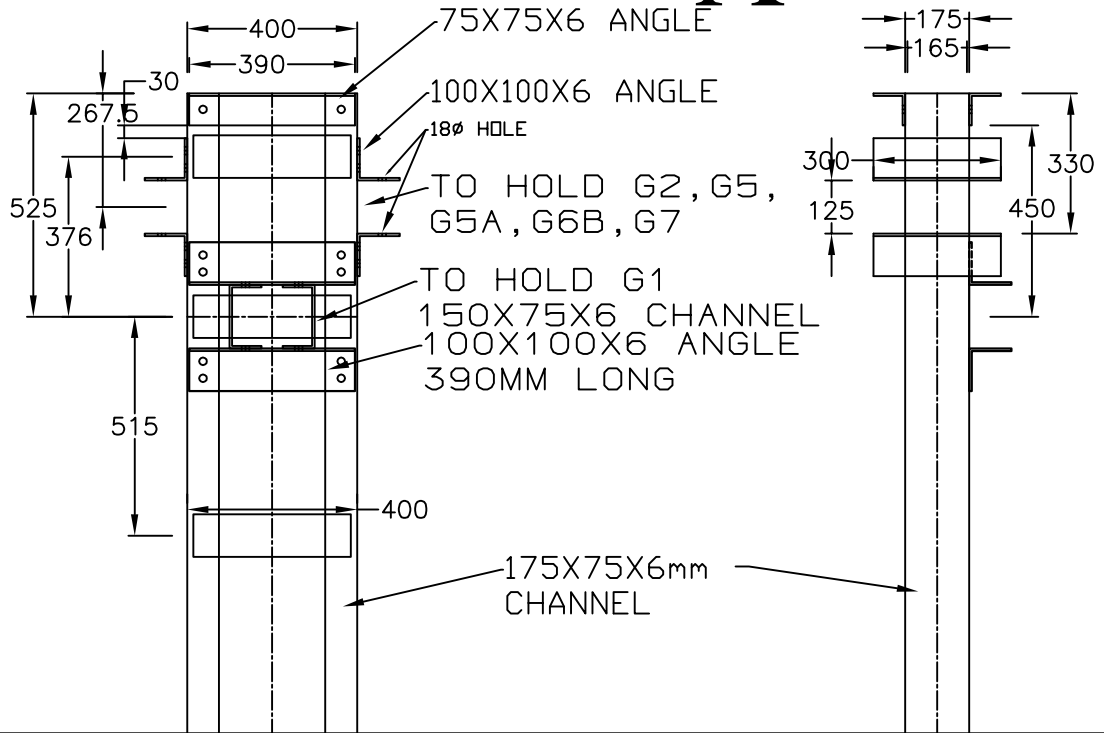

# T1A COLUMN

# B

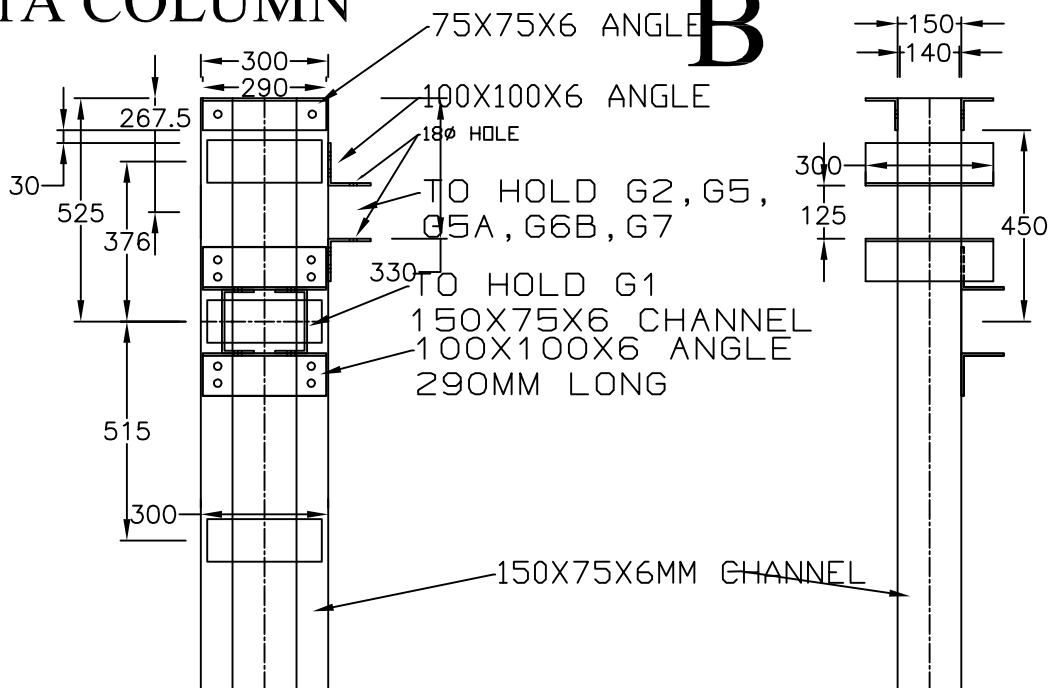

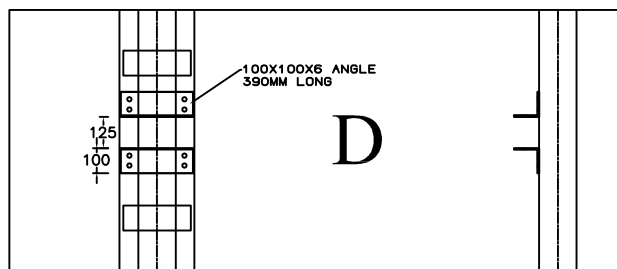
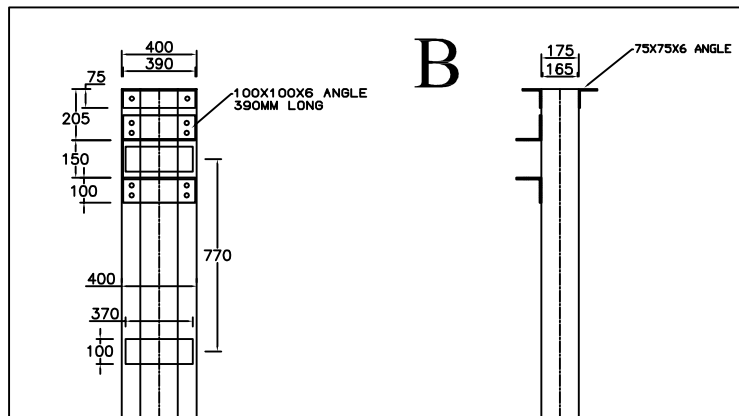
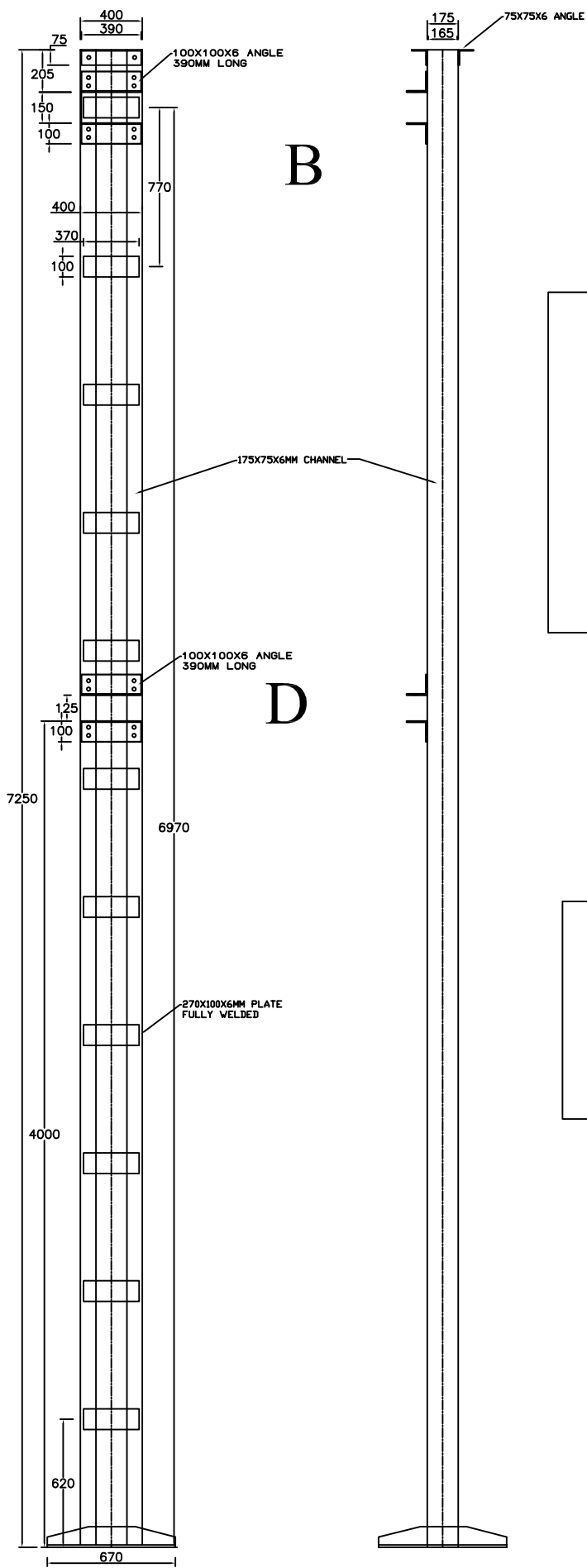

T2 COLUMN WITH BEAM ARRANGEMENT

# T3 COLUMN STRUCTURE

REV-1

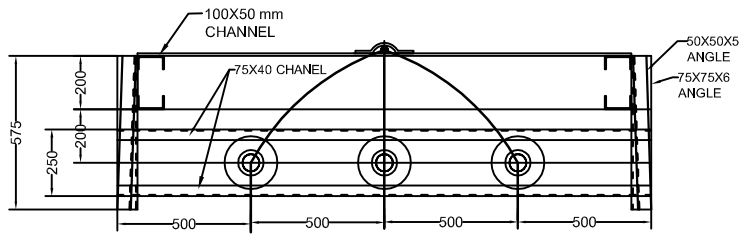

**PLAN**

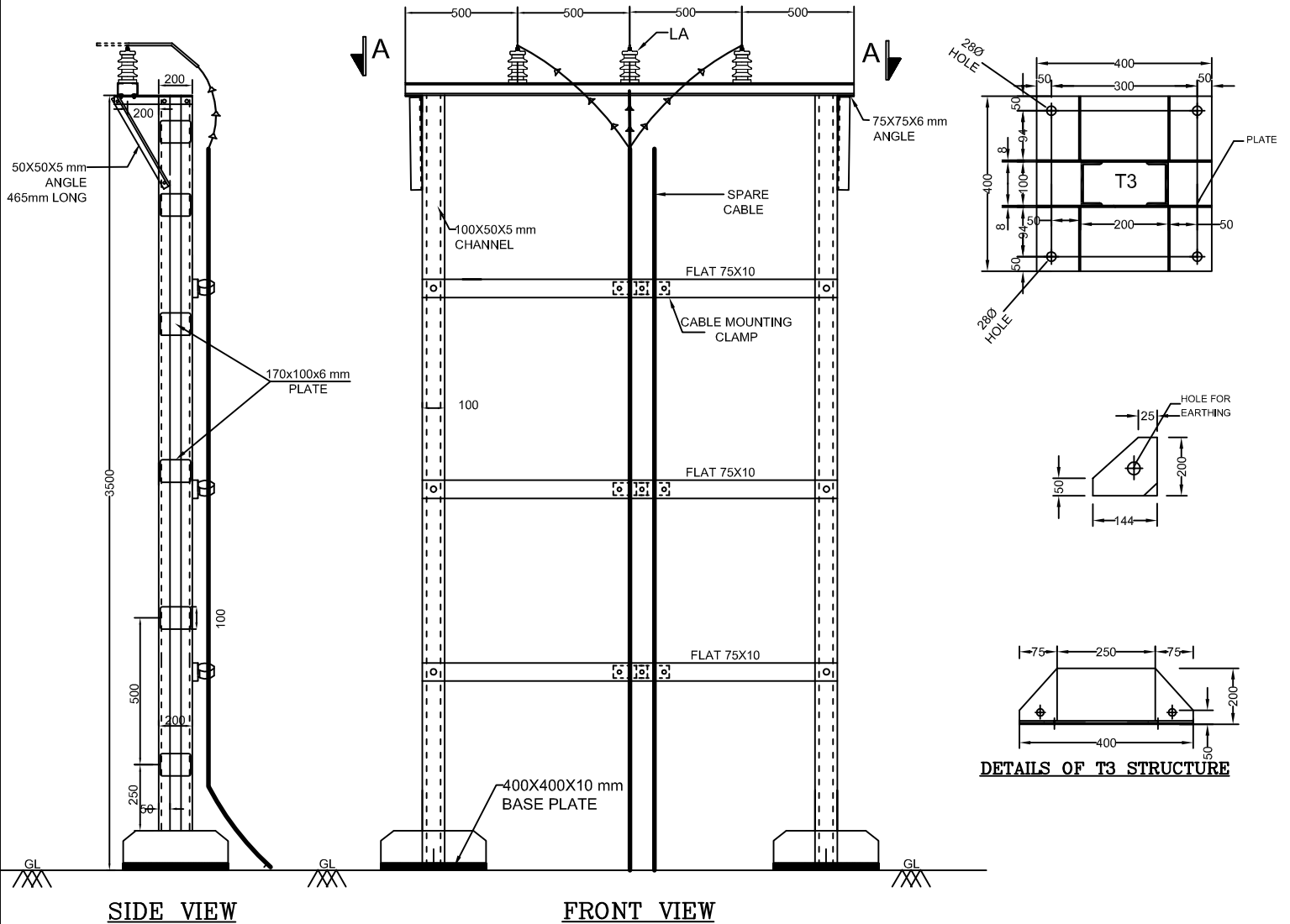

**SIDE VIEW**

**FRONT VIEW**

**DETAILS OF T3 STRUCTURE**

**SECTION A-A**

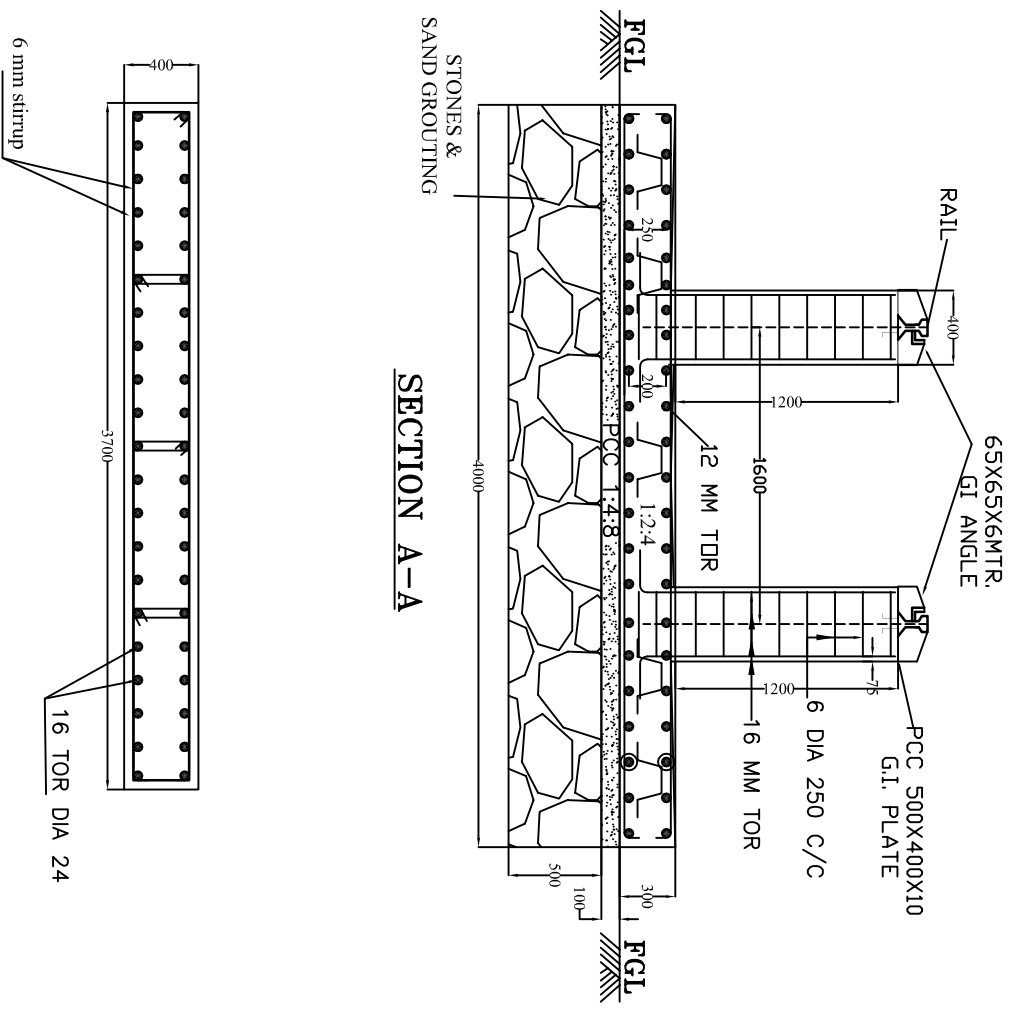

- NOTES:**
1. RAIL DISTANCE SHALL BE AS PER ACTUAL POWER TRANSFORMER RECEIVE AT SITE.

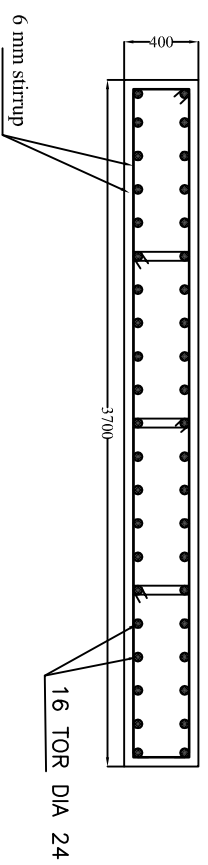

**HV SIDE**

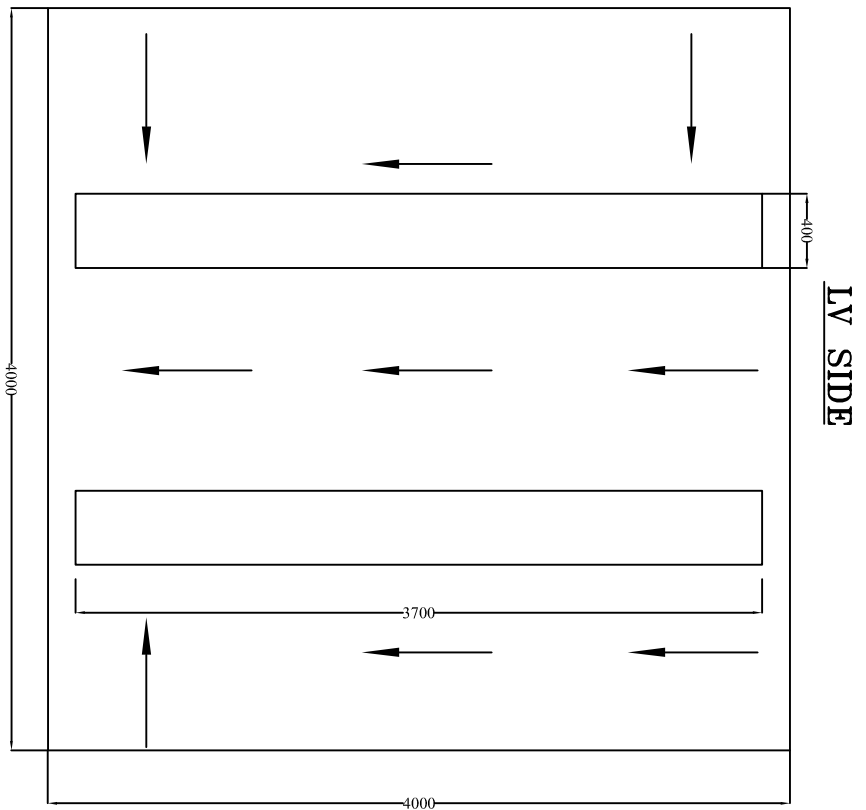



**CONTENTS**

<b>CLAUSE NO.</b>	<b>DESCRIPTION</b>
<b>1.0</b>	<b>ORGANIZATIONAL VALUES</b>
<b>2.0</b>	<b>ETHICS</b>
<b>3.0</b>	<b>CONTRACT PARAMETERS</b>
3.1	Issue/ Award of Contract
3.2	Contract Commencement Date
3.3	Contract Completion Date
3.4	Contract Period/Time
3.5	Contract Execution Completion Date
3.6	Contract Execution Period/Time
3.7	Contract Price /Value
3.8	Contract Document
3.9	Contract Language
3.10	Reverse Auction
<b>4.0</b>	<b>SCOPE OF WORK</b>
4.1	Technical Evaluation
4.2	Indemnity
4.3	Display of notice boards at work site
4.4	Disposal of waste at site
4.5	Deployment of workforce
4.6	Damage of Properties
4.7	Issuance of material
4.8	Company's right to use works
4.9	Rights of TPCODL to vary the scope work
<b>5.0</b>	<b>PRICES/RATES/TAXES</b>
5.1	For Supply part of Contract
5.2	For Service part of Contract
5.3	Changes in statutory Tax Structure

<b>CONTENTS</b>	
<b>CLAUSE NO.</b>	<b>DESCRIPTION</b>
<b>6.0</b>	<b>TERMS OF PAYMENT</b>
6.1	Pre-Requisites for Payment
6.2	Bills & Invoices
6.3	Payment & Statutory Deductions
6.4	Guidelines for Raising Running/Final Bills
6.5	Quantity Variation
6.6	Full and Final Payment
<b>7.0</b>	<b>MODE OF PAYMENT</b>
<b>8.0</b>	<b>SECURITY CUM PERFORMANCE DEPOSIT</b>
<b>9.0</b>	<b>STATUTORY COMPLIANCE</b>
9.1	Compliance to Various Acts
9.2	SA 8000
9.3	Affirmative Action
9.4	Compliance to Labour Laws
9.5	Compliance to C&D Waste Management Rules & Environment (Protection) Amendment Rules
<b>10.0</b>	<b>QUALITY</b>
10.1	Knowledge of Requirements
10.2	Material/Equipment/Works Quality
10.3	Adherence to Rules & Regulations
10.4	Specifications and Standards
<b>11.0</b>	<b>SAFETY</b>
<b>12.0</b>	<b>INSPECTION/PARTICIPATION</b>
12.1	Right to Carry Out Inspection
12.2	Facilitating Inspection
12.3	Third Party Nomination
12.4	Waiver of Inspections
12.5	Incorrect Inspection Call
<b>13.0</b>	<b>MDCC &amp; DELIVERY OF MATERIALS</b>
13.1	Material Dispatch Clearance Certificate

CONTENTS	
CLAUSE NO.	DESCRIPTION
13.2	Right to Rejection on Receipt
13.3	Consignee
13.4	Submission of Mandatory Documents on delivery
13.5	Dispatch and Delivery Instructions
<b>14.0</b>	<b>GUARANTEE</b>
14.1	Guarantee of Performance
14.2	Guarantee period
14.3	Failure in Guarantee period (GP)
14.4	Cost of repairs on failure in GP
14.5	Guarantee Period for Goods Outsourced
14.6	Latent Defect
14.7	Support beyond the Guarantee Period
<b>15.0</b>	<b>LIQUIDATED DAMAGES</b>
15.1	LD Waiver Request
15.2	Material Recovery
<b>16.0</b>	<b>ASSIGNMENT OR SUBCONTRACTING</b>
<b>17.0</b>	<b>UNLAWFUL ACTIVITIES</b>
<b>18.0</b>	<b>CONFIDENTIALITY</b>
18.1	Documents
18.2	Geographical Data
18.3	Associate's Processes
18.4	Exclusions
18.5	Violation
<b>19</b>	<b>INTELLECTUAL PROPERTY RIGHTS</b>
<b>20</b>	<b>INDEMNITY</b>
<b>21</b>	<b>LIABILITY &amp; LIMITATIONS</b>
21.1	Liability
21.2	Limitation of Liability
<b>22.0</b>	<b>FORCE MAJEURE</b>

Doc. Title	GENERAL CONDITIONS OF CONTRACT - COMPOSITE WORKS	
Rev. No	0	Page 4 of 104

<b>CONTENTS</b>	
<b>CLAUSE NO.</b>	<b>DESCRIPTION</b>
<b>23.0</b>	<b>SUSPENSION OF CONTRACT</b>
23.1	Suspension for Convenience
23.2	Suspension for Breach of Contract Conditions
23.3	Compensation in lieu of Suspension
<b>24.0</b>	<b>TERMINATION OF CONTRACTS</b>
24.1	Termination for default/breach of contract
24.2	Termination for convenience of associate
24.3	Termination for Convenience of TPCODL
<b>25.0</b>	<b>Dispute resolution and Arbitration</b>
25.1	Governing laws and jurisdiction
<b>26.0</b>	<b>ATTRIBUTES OF GCC</b>
26.1	Cancellation
26.2	Severability
26.3	Order of Priority
<b>27.0</b>	<b>INSURANCE</b>
<b>28.0</b>	<b>ERRORS AND OMISSIONS</b>
<b>29.0</b>	<b>TRANSFER OF TITLES</b>
<b>30.0</b>	<b>SUGGESTIONS &amp; FEEDBACK</b>
<b>31.0</b>	<b>CONTACT POINTS</b>
<b>32.0</b>	<b>LIST OF ANNEXURES</b>

Doc. Title	GENERAL CONDITIONS OF CONTRACT - COMPOSITE WORKS	
Rev. No	0	Page 5 of 104

## 1.0 ORGANIZATIONAL VALUES

The Tata Group has always been a value driven organization. These values continue to direct the Group's growth and businesses. The Six core Tata Values underpinning the way we do business are:

**Integrity** - We must conduct our business fairly, with honesty and transparency. Everything we do must stand the test of public scrutiny.

**Understanding** - We must be caring, respectful, compassionate and humanitarian towards our colleagues and customers around the world and always work for the benefit of India.

**Excellence** - We must constantly strive to achieve the highest possible standards in our day to day work and in the quality of goods and services we provide.

**Unity** - We must work cohesively with our colleagues across the group and with our customers and partners around the world to build strong relationships based on tolerance, understanding and mutual co-operation.

**Responsibility** - We must continue to be responsible and sensitive to the countries, communities and environments in which we work, always ensuring that what comes from the people goes back to the people many times over.

**Agility** - We must work in a speedy and responsive manner and be proactive and innovative in our approach.

## 2.0 ETHICS

In our effort towards Excellence and in Management of Business Ethics at TPCODL, an Ethics Management Team is constituted.

The main objective of the Ethics Management Team is to:

1. Record, address and allay the issues and concerns on ethics raised by different stakeholders like employees, consumers, vendors, Associates etc. by initiating immediate corrective actions.
2. Ensure proper communication of the ethics policies and guidelines through prominent displays at all offices of TPCODL and through printed declarations in all concerned documents where external stakeholders are involved.
3. Ensure proper framework of policies as preventive measures against any ethics violation recorded by them.
4. Prepare and submit MIS of all issues and concerns, corrective and preventive actions on monthly basis to the top management for their information.

All members of Team TPCODL, Associates and Stakeholders are requested to register any grievance on ethics violation on Central Control Telephone No. 011-66404040.

## 3.0 CONTRACT PARAMETERS

### 3.1 Issue/Award of Contract

TPCODL awards the contract to the Associate in writing in the form of Purchase order or Rate Contract (RC) hereafter referred as Contract, through in any or all of following modes- physical handover / post / e-mail / web document / fax with all the attachments/enclosures which shall be part of the contract document

Doc. Title	GENERAL CONDITIONS OF CONTRACT - COMPOSITE WORKS	
Rev. No	0	Page 6 of 104

On receipt of the contract, the associate shall return to TPCODL copy of the contract document duly signed by legally authorized representative of associate, within two days of Effective Date of Contract for contracts having contract execution time less than 30 days and within five days for all other contracts.

### **3.2 Contract Commencement Date**

The date of issue/award of contract shall be the Effective Date of Contract or Contract Commencement date.

### **3.3 Contract Completion Date**

The date of expiry of Guarantee Period (detailed in section 12 of this document) shall be deemed as the Contract Completion Date.

### **3.4 Contract Period/Time**

The period from Contract Commencement Date to Contract Completion Date shall be deemed as the Contract Period/Time.

### **3.5 Contract Execution Completion Date**

The stipulated date for completing the execution of all items in the schedule of quantities (Supply, Service and or both as applicable) shall be deemed as the Contract Execution Completion Date.

### **3.6 Contract Execution Period/Time**

The Period from Contract Commencement Date to Contract Execution Completion Date shall be the Contract Execution Period/Time. Timely Completion of Works/Timely Delivery of Materials is the essence of the contract. The period from effective date of contract to the date stipulated for completion of delivery of all items/completion of all the works/services, as per schedule of quantities of the contract is defined as contract execution completion time. The Delivery of Materials /The Completion of Works, as applicable, should be achieved in all respects as per schedules of quantities and all the terms and conditions of the contract, in the contract execution time.

Any revision/amendment in the originally stipulated contract execution time has to be approved by authorized representative of TPCODL.

### **3.7 Contract Price /Value**

The total all inclusive price/value mentioned in the LOI/PO/RC of the contract document is the Contract Price/Value and is based on the quantity, unit rates and prices quoted and awarded and shall be subject to adjustment based on actual quantities supplied/actual measurement of work done and accepted and certified by the authorized representative of the company unless otherwise specified in schedule of quantities or in contract documents.

### **3.8 Contract Document**

The Contract Document shall mean and include but not limited to the following:

- NIT/Tender Enquiry, QR, Instruction to Bidders, Special Condition of Contract (SCC) of tender, GCC, Technical & Commercial Specifications including relevant annexure and attachments).
- Bids & Proposals Received from Associate including relevant annexure/attachments.

Doc. Title	GENERAL CONDITIONS OF CONTRACT - COMPOSITE WORKS	
Rev. No	0	Page 7 of 104

- Letter of Intent (LOI/RC/PO) with agreed deviations from the tender/bid documents.
- All the Inspection and Test reports, Detailed Engineering Drawings.
- Material Dispatch Clearance Certificate (MDCC).
- Minutes of Meeting (MoM)

### 3.9 Contract Language

All documents, instructions, catalogues, brochures, pamphlets, design data, norms and calculations, drawings, operation, maintenance and safety manuals, reports, labels, on deliveries and any other data shall be in English Language.

The Contract documents and all correspondence between the TPCODL, Third Parties associated with the contract, and the Associate shall be in English language.

However, all signboards required indicating "Danger" and/or security at site and otherwise statutory required shall be in English, Hindi, and local languages.

### 3.10 Reverse Auction

TPCODL reserves the right to conduct the reverse auction (instead of public opening of price bids) for the products / services being asked for in the tender. The terms and conditions for such reverse auction events shall be as per the Acceptance Form attached in Annexure J. The bidders along with the tender document shall mandatorily submit a duly signed copy of the Acceptance Form as mentioned in the Annexure J as a token of acceptance for the same.

## 4.0 SCOPE OF WORK

All the activities that are to be undertaken by the Associate to realize the contractual deliverables in completeness form Scope of Work. Following clauses list, but not limited to, major requirements of the scope of work.

The associate shall satisfy himself and undertake fully the technical/commercial requirements of items to be supplied as listed in the Schedule of Quantities together with the tests to be performed /test reports to be furnished before dispatch, arrangement of stage and final inspections during manufacturing as per terms and conditions of contract, technical parameters & delivery terms and conditions including transit insurance to be met in order to fully meet TPCODL's requirements.

Completeness: Any supplies and services which might have not been specifically mentioned in the Contract but are necessary for the scope mentioned in Special Terms & Conditions and/or completeness of the works at the highest possible level, including any royalties, licence fees & compensation to be paid, whether incurred by the associates or by a third party for the work covered in the scope, regardless of when incurred, shall be supplied/provided by the associate without any extra cost and within the time schedule for efficient, smooth and satisfactory operation and maintenance of the works at the highest possible level under Indian conditions (but according to international standards for facility of this type), unless expressly excluded from the scope of supplies and services in this Contract.

TPCODL have the right, during the performance of the Contract, to change the scope and/or technical character of the Project and/or of the supplies and services stipulated in the

Doc. Title	GENERAL CONDITIONS OF CONTRACT - COMPOSITE WORKS	
Rev. No	0	Page 8 of 104

Contract by submitting a request in writing to the Associate. The Associate shall, within fifteen days of receipt of such request from the TPCODL, provide Purchaser with a reasonably detailed estimate of the cost of the change outlined in the request.

In the event, TPCODL requests a change, the Contract price and time shall be adjusted upwards or downwards, as the case may be and shall be mutually agreed to. The associate shall not be entitled to any extension of time unless such changes adversely affect the time schedule.

The Associate shall not proceed with the changes as requested till adjustment of contract price and time schedule where so applicable in terms of or otherwise directed by the TPCODL.

#### 4.1 Technical Evaluation

TPCODL reserves the right to assign scores to different parameters including but not limited to the following while evaluating the bids. TPCODL reserves the right to change the parameters and score without prior information to the associates:

S. No.	Evaluation Parameter	Max. Score
<b>A</b>	<b>Bidders already Registered with TPCODL</b>	<b>100</b>
	<b>Quality of the Products &amp; Services</b>	
	a. <u>For Supply Part:</u> No Material Rejections in last 2 years Deduction of 3 marks for each PO/ RO (for same product category) with major rejections in last 2 years. (Major rejection shall be considered when material is taken back by the vendor for rectification and the quantity of rejected material is more than 10%).	12
<b>A.1.</b>	b. <u>For Service Part:</u> No violation of statutory compliances in last 1 year. Deduction of 2 marks for each instance of violation in last 1 year.	12
	c. <u>Safety</u> Deduction of 2 marks for each instance of safety violation in last 1 year. Deduction of 4 marks for each reported Non-Fatal Accident in last 1 year. In case of any reported fatal accident: <b>ZERO MARKS</b>	16
<b>A.2.</b>	<b>Timely Execution of Contracts</b> Total Achieved Score = {30 – 3 x (Avg. %age LD deductions in last 2 years)}	30
<b>A.3.</b>	<b>Legal Issues with TPCODL</b> Zero instances of Arbitration procedures / Court Cases / PBG forfeitures in last 2 years: 30 marks else 'Zero' marks	30
<b>B</b>	<b>Bidders new to TPCODL</b>	<b>100</b>
	<b>Visits</b> <u>For Supply Part:</u> Factory Visit and Evaluation. <u>For Service Part:</u> Client Site Visit where the bidder is providing similar services.	30
<b>B.1.</b>	The visits as above shall be arranged by the bidder. However all costs towards conveyance, lodging, boarding etc. shall be borne by TPCODL. The score assigned by TPCODL based on the above visits shall be final and binding on the bidder.	
	<b>Safety:</b>	20



S. No.	Evaluation Parameter	Max. Score
	Score achieved against the BA safety Management System questionnaire.	
<b>B.2.</b>	<p><b>Client Referrals</b> At least 3 nos. Customer References for similar products/ services in last 3 years. All customer references shall be either of the following:</p> <ul style="list-style-type: none"> <li>▪ Govt. Organizations/ PSUs/ Power Distribution Utilities.</li> <li>▪ Private Organizations with an annual turnover of <math>\geq</math> 500 cr. PO copies or Completion Certificates are admissible.</li> </ul> <p>Each reference: 10 marks</p>	30
<b>B.3.</b>	<p><b>Blacklisting Information</b> Not blacklisted by any reputed organization / utility in last 2 years: 20 marks else 'Zero' marks.</p>	20

- Bidder shall be considered as technically qualified if they are able to achieve a technical score of  $>70$  marks on the above parameters. 'A' or 'B'.
- The bidder must have the PF and ESI registration. In case it is not there (provided the bidder is not exempted from the PF and ESI), bidder shall not be evaluated on the above parameters and will be considered as disqualified.

#### 4.2 Indemnity

Associates shall undertake to fully indemnify TPCODL (also referred to as the Company in the GCC) against all kinds of liabilities or damages, of whatsoever nature, including compensation arising from any accident to the person or property of those in Associate's employment or to any other person or properties including those of TPCODL, arising due to reasons attributable to any, act, omission or negligence of the Associate the Associates, for the entire period of contract including period of guarantee.

Within 7 days of award of work, the Associates shall submit Indemnity Bond in the format as per Annexure-E to Order Issuing Authority.

Contract having value more than Rs 2 Cr per Annum, Associates shall submit Indemnity Bond on Rs 100/- Non Judicial Stamp Paper in the format as per Annexure- E to Order Issuing Authority.

#### 4.3 Display of Notice Boards at Work Sites

The Associate shall put up display notice board at each project site where the works are in progress indicating the information given below:

- Name of the Project.
- Estimated Cost of Project.
- Date of Commencement.
- Expected date of completion.
- Name of Associate and his telephone number.
- Name of Engineer-in-Charge and his telephone number.

#### 4.4 Disposal of Waste at Site

Significant quantities of waste are generated during the execution of project and an integrated approach for effective handling, storage, transportation and disposal of the same shall be adopted. This would ensure the minimization of environmental and social impact in order to combat the climate change.

Doc. Title	GENERAL CONDITIONS OF CONTRACT - COMPOSITE WORKS	
Rev. No	0	Page 10 of 104

The associates shall follow the below criteria for disposal of waste at site during the execution of project.

- Associate shall ensure that the detailed project plan include the waste management, segregation of all designated waste material (Recyclable/ Non-Recyclable), collecting, storing, disposing and transferring the same to pre-arranged facility/destination in timely and safe manner as per environmental legislations during the execution of project. The project plan shall also include the innovative construction practice to eliminate or minimize waste, protect surface/ground water, control dust and other emissions to air and control noise during the execution of project. The copy of same shall be given to EIC before the commencement of project.
- The purchase policy of BA shall encourage the procurement of material with recycled and minimum packaging of goods during delivery. Associate shall provide the appropriate means for site to site transportation of materials to avoid damage and litter generation.
- Associate shall educate and inform to its project team about the requirement and responsibilities for waste minimization and disposal in general and provide training of practices that support this. Waste management should be treated like a safety program.
- In the event that area of contaminated or biological hazard is identified, Associate shall ensure that plant, equipment, personnel and any activity associated with the work is carried out in consultation with EIC of TPCODL.
- Associate shall ensure that the residents living near the site are kept informed about proposed working schedule and shall informed timings and duration of any abnormal noise full activity that is likely to happen.
- Associate shall ensure the regular maintenance and monitoring of vehicles and equipment for efficient fuel use so that emissions and noise are within acceptable limits to avoid air pollution.

#### **4.5 Deployment of Work Force**

Associate shall deploy adequate labour, as considered necessary by TPCODL for execution of the contract including Sundays and Holidays whenever required to do so with no extra cost to TPCODL. However, prior permission shall be taken from the site Engineer to carry out the work beyond normal working hours or on Sundays and Holidays. Female employees shall not be deployed beyond normal working hours/days and no child labour shall ever be deployed. Associate shall depute full time qualified and experienced engineers to supervise the work at site. All such staff shall be maintained from commencement to completion of all works to the entire satisfaction of the Engineer-in-Charge. Associate's employees deployed for the works under this contract will not be considered in Company's employment at any time. Associate shall continue to be responsible for all such employees, their safety, all types of statutory compliances related thereto and in any other manner whatsoever. The company will stand indemnified by the Associate in respect of all the above. At the same time Company upon noticing any breach or default on any statutory compliances, may at their sole discretion, decide to act in a manner as deemed fit at the risks and costs of the Associate.

Doc. Title	GENERAL CONDITIONS OF CONTRACT - COMPOSITE WORKS	
Rev. No	0	Page 11 of 104

TPCODL shall have the right to instruct the Associate to change the Sub- Associates or skilled /unskilled workers in case the conduct, the workmanship or speed of the work is not satisfactory.

Associates shall submit duly signed undertaking regarding engagement of competent staff / employee commensurate to the nature of job to Engineer-in-charge in the format attached as Annexure – H.

#### **4.6 Damages to Properties**

The Associates shall take necessary steps to ensure that the equipment and installations of the Company, Third parties, including other utility services like water supply pipelines; open drains telephone cables etc. are not damaged during execution of the works. The Associates shall be responsible for all such damages and shall have to repair/ replace and/or compensate for the entire claims in respect of such damages at its own cost.

#### **4.7 Issuance of Material**

The material issued to the Associate shall be in the custody of the Associates who shall be fully responsible for the same. After completion of the works, the Associates will reconcile the material. Any cost of material which is short or damaged/lost will be deducted from Associate bill/ deposits.

#### **4.8 Company's Right To Use Works**

If Taking Over Certificate is delayed for any reason, for which TPCODL's decision shall be final and binding upon the Associate, the Company shall be entitled to use the works or portion thereof without affecting Associate's responsibility and liability to complete the balance works as per company's directives from time to time, though Associate shall be afforded reasonable opportunity by the company to enable Associates to complete all balance works required for issuance of 'Taking Over Certificate' by the company.

#### **4.9 Rights of TPCODL to vary the scope work**

TPCODL shall have the right, during the performance of the Contract, to change the scope and/or technical character of the Project and/or of the supplies and services stipulated in the Contract by communicating the intent to do so in writing to the Associate. On receipt of such communication the Associate shall, within the time frame specified in the contract shall provide TPCODL with a reasonably detailed estimate of the cost of the change in scope outlined in the TPCODL communication. The change in the Contract price and time shall be revised upwards or downwards, as the case may be, and shall be mutually agreed to. The Associate shall not be entitled to any extension of time unless such changes adversely affect the time schedule.

The Associate shall not proceed with the changes in the scope of work till such time revision of Contract price and time schedule are approved and communicated to the associate by TPCODL.

Any change in the Scope of Work and/or Terms & Conditions of the order shall be intimated by TPCODL through an amendment to the contract. The amendment shall be treated valid only if signed by the authorized signatory of the original contract.

### **5.0 PRICES/ RATES/ TAXES**

#### **5.1 For Supply part of Contract**

Doc. Title	GENERAL CONDITIONS OF CONTRACT - COMPOSITE WORKS	
Rev. No	0	Page 12 of 104

Unless specified elsewhere in the contract document, the prices/rates are inclusive of cost of finished product for which MDCC will be issued by TPCODL, packaging and forwarding charges, freight and transit insurance charges covering loading at Associate's works, transportation to TPCODL store/site & unloading & delivery at TPCODL stores/TPCODL site, cost of documentation including all the relevant test certificates and other supportive documents to be furnished.

The Prices/Rates are inclusive of all taxes, levies, cesses and duties, particularly Goods and Services Tax as applicable. All government levy / taxes shall be paid only when the invoice is submitted according to the relevant act.

The prices/rates shall remain firm till actual completion of entire supply of goods/material/equipment as per contract is achieved and shall remain valid till the completion of the contract.

The prices shall remain unchanged irrespective of TPCODL making changes in quantum in all or any of the schedules of items of contract.

### **5.2 For Service part of Contract**

The Prices and Rates are inclusive of cost of materials supplied as per contract terms and for which MDCC is issued by TPCODL and to the extent required for completion of works, cost of service executed as per schedule of quantities, cost of testing as per contract terms, cost of documentations including all relevant test certificates and other supportive documents to be furnished as per contract terms. The rates shall remain firm till actual completion of contract.

The Prices/Rates are inclusive of all taxes, levies, cesses and duties, particularly Goods and Services Tax as applicable. All government levy / taxes shall be paid only when the invoice is submitted according to the relevant act.

The prices shall remain unchanged irrespective of TPCODL making changes in quantum in all or any of the schedules of items of contract.

### **5.3 Changes in Statutory Tax Structure**

If rate of any or all of the statutory taxes and duties applicable to the contract changes, such changes shall be incorporated by default if the changes occur within the contract execution time and shall be applicable if the contract is executed by the Associate within the Contract Execution Time.

For execution of contracts beyond contract execution time, where the delay is not attributable to TPCODL no upward revision in tax /duties shall be considered irrespective of changes in the statutory tax structure either within the contract execution time or beyond. However, in such cases, benefits due to any downward revisions in statutory tax rates shall be passed on to TPCODL.

### **6.0 TERMS OF PAYMENT**

- A. 5% of the Release Order/ Purchase Order price shall be paid as initial interest free advance on fulfillment of the following by the Associate:
  - a) Acceptance of PO/ LOI.
  - b) Submission of advance payment BG of 15% of the Release Order/ Purchase Order price which shall remain valid till the advance is fully adjusted.

Doc. Title	GENERAL CONDITIONS OF CONTRACT - COMPOSITE WORKS	
Rev. No	0	Page 13 of 104

- c) Submission of Contract Performance Bank Guarantee of 5/10% of the RC/ PO price valid till 30 days after taking over of the works.
- B. 10% of the Release Order/ Purchase Order price shall be paid as interest free advance against approval of drawings under Category-1 of major drawings, Quality Plans, Pert Chart, Field Quality Plan, posting of Project Manager and commencement of the first mile stone of the work mutually agreed including C-3 Form, and submission of a true copy of 'Erection All Risk Insurance Policy' taken for the awarded jobs. The drawing list shall be mutually agreed at the time of award of work.
- C. 50% on account payment of the total of item wise cost of material Release Order/ Purchase Order shall be paid against receipt of material at site in good condition and certification by TPCODL along with bills complete in all respects viz. MDCCs etc.
- D. 20% on account payment of the actual executed value shall be paid against mechanical completion of erection on prorata basis against monthly bills and 70% on account of the actual executed value shall be paid against the service line item including composite line item. In case this milestone is not completed beyond 120 days for reasons attributable to TPCODL, the payment corresponding to supply part shall be released subject to submission of BG of equivalent amount by the BA valid for a period of further 12 months. If required, it shall be extended by the BA on request of TPCODL.
- E. 15% payment of the actual executed Release Order/ Purchase Order shall be paid after completion of acceptance test and Taking Over of the complete systems specified in the enquiry, including clearance of Electrical Inspection, compliance of final punch point and after reconciliation & adjustment of payments, if any, towards Quantities of materials issued from purchaser's stock and consumed by the contractor for expeditious completion of the job. In case this milestone is not completed beyond 120 days beyond schedule for reasons attributable to TPCODL, the payment corresponding to supply part shall be released subject to submission of BG of equivalent amount by the BA valid for a period of further 12 months. If required, it shall be extended by the BA on request of TPCODL.

The Contractor shall submit all Operation & Maintenance manuals and "As Built Drawings" etc. and shall also submit Equipment Warranty Bank Guarantee (EWBG) equivalent to 5/10% of actual executed contract price before the release of this last payment and return of CPBG. The validity of EWBG shall be for a period of 15 months from the date of taking over of the works or specified guarantee period in drawing/tender/technical specification documents etc. whichever is later. The associate shall also submit 'No Demand Certificate' at the time of receipt of full and final payment.

### 6.1 Pre-Requisites for Payment

- Associate should have completed execution of that part of contract, for which payment is sought, to the satisfaction of TPCODL's Engineer-in-Charge responsible for the contract and obtained certification for execution of the work.
- Associate has undertaken joint measurement of the work executed along with TPCODL's Engineer-in-charge

Doc. Title	GENERAL CONDITIONS OF CONTRACT - COMPOSITE WORKS	
Rev. No	0	Page 14 of 104

- Associate's bills/invoices submitted have been certified by Engineer-In-Charge.

## 6.2 Bills & Invoices

Unless specified otherwise in the special conditions of contract, Associate shall raise not more than one invoice/contract per month for the services rendered in the prescribed Tax Format and the invoice shall be submitted within 15 days of the following month at Bill Inward Receipt Desk (BIRD) located at Civil Lines III Office, TPCODL.

All Bills shall be supported by joint measurement of work done, quality test report and a copy of wage sheet, if applicable (showing proof of having disbursed wages as per applicable law) and a copy of statement substantiating that statutory payments having been affected.

Bills/ invoices shall mention Associate's 'Sales, Service, WCT Tax Registration Number, PAN number as applicable.

Final bill submission after completion of project or execution of job must be within 30 days from the actual date of completion/execution of work awarded.

## 6.3 Payment & Statutory Deductions

Payment shall be released within 30 days from the submission of the bills. The associate shall submit "No Demand Certificate" in the format as per Annexure-D at the time of receipt of full and final payment. In case any non-compliance to contract conditions comes to TPCODL's notice, TPCODL will be entitled to deduct 30% of estimated wages plus 20% of wages as TPCODL's overheads. Associates would be obliged to provide the copy of monthly wage sheet in any case, failing which no payment shall be made. TPCODL at their sole discretion may deposit the PF etc. with statutory authorities. TPCODL will deduct the amounts of TDS as per statutory requirement under the income tax act and the DVAT Act and certificates (wherever applicable) will be issued to associate accordingly.

In case of non-submission of PAN No TDS @ 20% shall be deducted from all payable amounts for which no TDS certificate shall be issued. TDS once deducted as above shall not be revised in any condition.

### 6.3.1 Statutory Deductions

TPCODL will deduct the amounts of TDS, TCS as per statutory requirement under the income tax act, the Goods and Services tax act, BOCW Act, or any other applicable tax act and certificates (wherever applicable) will be issued to associate accordingly. For consumption of TPCODL's Water and Electricity by Associate for execution of Contract, Associate shall pay 0.5% & 1.0% respectively of contract value and it shall be deducted from the running bills. The Engineer-in-Charge as stated in the Order shall be responsible for certification of the work executed and the bills. Bills (including original) shall be submitted in triplicate at Bill Inward Receipt Desk (BIRD) located at Civil lines-III, Near Vidhan Sabha, TPCODL.

## 6.4 Guidelines for Raising Running/Final Bills

Contract Value Up to 5 Lakhs	One Final Bill
Contract Value More than 5 lakhs	Monthly Running Bill & One Final Bill

All Bills shall be processed only when all bank Guarantees are in place and before payments of Final Bill Associate have to furnish NDC.

Doc. Title	GENERAL CONDITIONS OF CONTRACT - COMPOSITE WORKS	
Rev. No	0	Page 15 of 104

## 6.5 Quantity Variation

Payment will be made on the basis of actual quantity of supplies/actual measurement of works accepted by TPCODL and not on the basis of contract quantity.

## 6.6 Full and Final Payment

Full & Final Payment in all contracts shall be made subject to the associate submitting "No Demand Certificate" in the format as per Annexure-D.

## 7.0 MODE OF PAYMENT

Payment shall be made through RTGS mode for which Business Associated shall submit the details of Bank Account and other details as per annexure K. Further, for any payments made, TPCODL is not responsible for any consequences/disputes Associate have among the owners channel partners, sub-Associates and all such dispute/concerns shall be settled solely by the Associate.

The quantities of items indicated are estimated and preliminary. However, payments shall be made on the basis of actual quantity of work carried out and measured jointly by the Company and the Associate. Associates shall be responsible to organize joint measurements of works with TPCODL Engineer-in-Charge before raising any bill of work done. In the event Associate fails to do so, TPCODL at their sole discretion, may take measurements of work done and proceed as deemed fit and in such an event Associate's right to lodge any subsequent claim shall stand forfeited.

## 8.0 SECURITY CUM PERFORMANCE DEPOSIT

Associates shall submit within 15 days from the effective date of issue of PO/RC, Security cum Performance Guarantee (SPBG) in the format as per Annexure B of this document from banks acceptable to TPCODL for:

(a) 5% of the PO value if purchase order value is more than Rs 5 Crores.

(b) 10% of the PO value if purchase order value is less than Rs 5 Crores.

This shall remain valid till the end of the Guarantee Period of contract, plus one month.

(c) 5% of the RC value in case of Rate Contract. This shall remain valid till the Guarantee period plus one month.

- For PO/RC values less than Rs. 5 lacs, Associate may request for deduction of amount equivalent to SPBG value from their first invoice. Such amount shall be withheld by TPCODL while processing the invoice and shall be released after completion of Guarantee Period plus one month.
- For PO/RC values less than Rs. 3 lacs, the clause (8.0) for Security cum Performance Bank Guarantee (SPBG) shall not be applicable..
- In case of RC (Rate Contract) after the expiry of RC validity, Associate shall have to submit SPBG. However, the Associate has the option to re-submit the SPBG as per actual RO (Release Order) value issued against the RC, valid for Guarantee Period plus one month. The Guarantee Period shall be considered as per the last RO issued against the said RC. The original SPBG as submitted against the RC shall be released on submission of the new SPBG to TPCODL. Alternatively, Associate may extend the

Doc. Title	GENERAL CONDITIONS OF CONTRACT - COMPOSITE WORKS	
Rev. No	0	Page 16 of 104

validity of original SPBG only till the requisite period, i.e. Guarantee Period plus one month.

## 9.0 STATUTORY COMPLIANCE

### 9.1 Compliance to Various Acts

Associate should ensure adherence to all applicable laws, rules and regulation applicable under this contract from time to time. In case of violation any risk, costs etc shall be in associates account and keep TPCODL indemnified always till completion of contracts.

### 9.2 SA 8000

Further being TPCODL is SA 8000 complied and expects its Associates to follow guidelines of SA8000: 2014 on the following aspects

1. Child Labour
2. Forced or Compulsory Labour
3. Health & Safety
4. Freedom of Association & Right to Collective Bargaining
5. Discrimination
6. Disciplinary Practices
7. Working Hours
8. Remuneration
9. Management System

### 9.3 Affirmative Action

TPCODL appreciate and welcome the engagement/employment of persons from SC/ST community or any other deprived section of society by their business associates.

#### Relaxation in Contract Clauses under Affirmative Action for SC/ ST Business Associates\*\*

TPCODL believes that inclusive growth is the key to sustainable development, and to promote the same Policy on Affirmative Action for Scheduled Caste & Scheduled Tribe Communities has been adopted across the company.

Under the same pre-text, and to promote entrepreneurship among SC/ST community TPCODL has taken initiative by proposing relaxations in contract clauses as per below:

S. No.	Initiative	for SC/ ST BA's	Guideline Document
1	Tender Fees	100% waiver for SC/ST community	All Open Tenders
2	Earnest Money Deposit	50 % relaxation of estimated EMD value	All limited and Open Tenders
3	Performance Bank Guarantee	25% relaxation in PBG for order value above 50 lacs else 50% relaxation	All limited and Open tenders
4	Turnover	25% relaxation in company turnover under qualifying requirement criteria	All Open Tenders



Doc. Title	GENERAL CONDITIONS OF CONTRACT - COMPOSITE WORKS	
Rev. No	0	Page 17 of 104

**\*\*Classification of BAs under SC/ST shall be governed under following guidelines:**

- Proprietorship/ Single Ownership Firm: Proprietor of the firm should be from SC/ST community. Governing document shall be duly audited balance Sheet for the last FY bearing the name of proprietor.
- Partnership Firm: Only such firms shall qualify which have SC/ST partners holding equal to or more than 50% of the total ownership pattern of the firm. Governing document shall be Partnership Deed and audited balance sheet/ ITR for last FY.
- Private limited company: Only such firms shall qualify which have SC/ST directors holding equal to or more than 50% of the total ownership pattern of the firm. Governing document shall be Memorandum of Understanding (MoU) and/or Article of Association (AoA).

*## Certification from SC/ST commission shall be required for deciding upon SC/ST status of a person.*

#### **9.4 Compliance to Labour Laws**

Bidder needs to ensure compliance to applicable labour laws including timely disbursement of wages. In case wages are not disbursed as per the stipulated timelines, then TPCODL shall pay the wages to BA employees on behalf of BA. Apart from deducting the amount of wages paid, TPCODL shall deduct an additional service charge equivalent to 25% of the wages paid from the payment due to BA.

#### **9.5 Compliance to Construction and Demolition Waste Management Rules & Environment (Protection) Amendment Rules**

BA is liable to follow the Construction and Demolition Waste Management Rules- 2016, Environment (Protection) Amendment Rules- 2018 and Guidelines on dust mitigation measures in handling construction material and C&D wastes issued by CPCB.

Following are some main points of above Rules/Guidelines for Construction work, cable laying jobs etc.

1. Barricading to be provided at site to cover complete area.
2. Construction material and waste should be inside the closed area made by using barricading.
3. Water sprinkling/fine spray from nozzles to be done to suppress the dust.
4. The board of Dust mitigation measures shall be displayed at site for public viewing with required details.
5. Loose sand or soil and construction material that causes dust shall be covered.
6. Transport material that are easily wind borne need to be covered by a sheet made of either jute, tarpaulin, plastic or any other effective material.
7. All areas for storing C&D waste/construction material to be demarcated and preferably barricaded particularly those materials that have potential to be dust borne.
8. Grinding and cutting of building materials in open area shall be prohibited.
9. Construction material and waste should be stored only within earmarked area and road side storage of construction material and waste shall be prohibited.
10. No uncovered vehicles carrying construction material and waste shall be permitted.
11. Construction and demolition waste processing and disposal site shall be identified and required dust mitigation measures to be notified at the site.

Doc. Title	GENERAL CONDITIONS OF CONTRACT - COMPOSITE WORKS	
Rev. No	0	Page 18 of 104

## **10.0 QUALITY**

### **10.1 Knowledge of Requirements**

The Associate shall be deemed to have carefully examined and to have knowledge of the equipment, the general and other conditions, specifications, schedules, drawings, etc. forming part of the Contract and also to have satisfied himself as to the nature and character of the work to be executed and the type of the equipment and duties required including wherever necessary of the site conditions and relevant matters and details. Any information thus procured or otherwise obtained from TPCODL/Consultants shall not in any way relieve the Associate from his responsibility and executing the works in accordance with the terms of contract.

### **10.2 Material/Equipment/Works Quality**

The items / works under the scope of the Associate shall be of the best quality and workmanship according to the latest engineering practice and shall be manufactured from materials of best quality considering strength and durability for their best performance and, in any case, in accordance with the specifications set forth in this Contract. All material shall be new. Substitution of specified material or variation from the process of fabrication/construction/manufacture may be permitted but only with the prior written approval of the TPCODL.

### **10.3 Adherence to Rules & Regulations**

The Associate shall procure and/or fabricate/erect all materials and equipment in accordance with all requirements of Central and State enactment, rules and regulations governing such work in India and at site. This shall not be construed as relieving the Associate from complying with any requirement of TPCODL as enumerated in the Contract which may be more rigid than and not contrary to the above mentioned rules, nor providing such construction as may be required by the above mentioned rules and regulations. In case of variance of the Technical Specification from the laws, ordinance, rules and regulations governing the work, the Associate shall immediately notify the same to the TPCODL. It is the sole responsibility of the Associate, however, to determine that such variance exists. Wherever required by rules and regulations, the Associate shall also obtain the statutory authorities' approval for the plant, machinery and equipment to be supplied by the Associate.

### **10.4 Specifications and Standards**

The Associate shall follow all codes and standards referred in the Contract Document. Codes and standards of other may be followed by the Associate with the prior written approval of TPCODL, provided materials, supplies and equipment according to the standard are equal to or better than the corresponding standards specified in the Contract.

Brand names mentioned in the Contract documents are for the purpose of establishing the type and quality of products to be used. The Associate shall not change the brand name and qualities of the bought out items without the prior written approval of the TPCODL. All such products and equipment shall be used or installed in strict accordance with original manufacturer's recommendations, unless otherwise directed by the TPCODL. In any

Doc. Title	GENERAL CONDITIONS OF CONTRACT - COMPOSITE WORKS	
Rev. No	0	Page 19 of 104

circumstances the codes, specimen and standards prescribed by any government agency should not be violated.

## 11.0 SAFETY

All Associates shall strictly abide by the guidelines provided in TPCODL's Contractor Safety Management System (CSMS) as applicable at all stages during the contract period. Associate shall execute the contracts ensuring the following in and as order of priority:

- Safety of Human Beings.
- Safety of equipment/Assets.
- Timely Completion of Contract.

Safety related requirements as mentioned in our Contractor Safety Management System is attached as annexure L and is an integral part of this GCC.

## 12.0 INSPECTION/PARTICIPATION

### 12.1 Right to Carry Out Inspection

TPCODL reserves the right to send its representatives for inspection or participation at various stages of contract execution listed below, applicable as per contract construction.

- During basic design and detail engineering of material/ Equipment carried out by Associate /Outsourced Agencies.
- During manufacturing stages of the product at Associate's/Associate's Outsourced Agency's Plant/Facility.
- During Pre-dispatch Inspection and Testing of finished/manufactured product at Associate's/Associate's outsourced Agency's Plant/Facility.
- During Installation & Commissioning Activities/Stages.
- Prior to Clearing of the completed installation for commissioning.
- Any other stage as find appropriate by TPCODL during contract execution time.

All inspections and participations shall be carried out within maximum of two weeks of TPCODL giving written intimation to the Associate or receiving appropriate advance written inspection call from the Associate, unless otherwise specified elsewhere in the contract document.

### 12.2 Facilitating Inspection

The Associate shall provide all opportunities and information to TPCODL's engineers to get acquainted with the technical know-how and the methods and practices adopted by the Associate in basic and detail engineering. The Associate shall provide documents, drawings, calculations etc. as may be required by TPCODL's Engineers.

The Associate shall provide free of charge office accommodation, office facilities, secretarial services, communication facilities, general and drawing office stationary, etc. as may be reasonably required by the TPCODL's engineers. Similarly, facilities shall also be provided by Associate's outsource agencies/partners/authorized dealers (collectively termed as sub-associates) if such basic and detail engineering activities are carried out in the design offices of sub-Associates.

Doc. Title	GENERAL CONDITIONS OF CONTRACT - COMPOSITE WORKS	
Rev. No	0	Page 20 of 104

The Associate shall be responsible for the safety of employees of TPCODL/Third Party Agency when they are at the Associate's /Associate's outsource agency's plant or facility for carrying out/witnessing inspection/testing. All statutory safety precautions as applicable shall be followed by the Associate during Inspection Testing. If TPCODL inspectors are not satisfied with the safety arrangements at the plant, TPCODL have the right to call off inspection till such time corrective action is taken by the Associate.

Before raising the call for pre-dispatch final inspection and testing, the Associate shall conduct all the tests—type tests, routine tests etc-as specified in the contract document and submit copies of the test certificates to TPCODL along with the inspection call, for scrutiny of TPCODL.

The Associate and TPCODL shall jointly document all the observations, comments and action points after completion of inspection and it shall be binding on the Associate to provide compliance on all the points requiring compliance and furnish the compliance report to the designated authority of TPCODL for receiving clearance for dispatch of materials.

### **12.3 Third Party Nomination**

TPCODL also may nominate a third party for the purpose of carrying out the inspection and such an agency shall be entitled to all the rights and privileges of TPCODL as far as conducting the inspection.

### **12.4 Waiver of Inspections**

TPCODL on its own discretion shall chose to waive off any inspection and ask the Associate to submit all the test reports as applicable as per contract specifications, related to inspection and testing of the goods ordered for scrutiny and clearance for dispatch.

### **12.5 Incorrect Inspection Call**

In case it is observed that the material offered for inspection is not ready at the time of TPCODL inspection visit rendering it as futile, all costs towards such inspection shall be recovered from the BA. Taxes as applicable on such recoveries shall be borne by the BA.

## **13.0 MDCC & DELIVERY OF MATERIALS**

### **13.1 Material Dispatch Clearance Certificate**

Associate shall deliver material/goods/equipment against Supply Contracts or Supply Part of Composite/Service Contracts only after receiving Material Dispatch Clearance Certificate (hereafter termed as MDCC) issued by designated authority of TPCODL. Material delivered at TPCODL stores or at project site without a valid MDCC issued by the designated official of TPCODL shall be rejected. MDCC shall be issued to associate furnishing compliance report on the action points documented during pre-dispatch inspection and testing at Associate's/ Sub-Associate's plant/ facility. In case Pre-dispatch inspection is waived at the discretion of TPCODL, then, MDCC shall be issued on receiving all the test reports-routine& type-from the Associate and finding them in order.

The associate shall include and provide for securely protecting and packing the materials so as to avoid loss or damage during handling and transport by air, sea, rail and road or any other means.

All such packing shall allow to the extent possible for easy removal and checking at Site. The associate shall take special precautions to prevent rusting of steel and iron parts during

Doc. Title	GENERAL CONDITIONS OF CONTRACT - COMPOSITE WORKS	
Rev. No	0	Page 21 of 104

transit by sea. Gas seals or other materials shall be utilised by the associate for protection against moisture during transit of all Plant and Equipment.

Each Equipment or parts of Equipment shall be tagged with reference to the assembly drawings and corresponding part numbers. Each bale or package shall contain a packing note quoting specifically the name of the associate, item description, quantity, item / package identification.

All packing cases, containers, packing and other similar materials shall be new and supplied free by the associate and it shall not be required to be returned to the associate.

Notwithstanding anything stated in this clause, the associate shall be entirely responsible for loss, damage or depreciation or deterioration to the materials and supplies due to faulty and/or insecure packing or otherwise during transportation to the Site until otherwise provided herein.

In case of the consignments dispatched by road, the associate shall ensure that it or its sub-contractors:

- i) Identify and obtain the correct type of trucks/trailers, keeping in view the nature of consignments to be dispatched.
- ii) Take such actions as may be necessary to avoid all possible chances of damages during transit and to ensure that all packages are firmly secured.

Timelines for inspection and MDCC is as below:

S. No.	Inspection	MDCC issuance time including inspection time (max.)
1	Outside Bhubaneswar	12 days
2	Within Bhubaneswar	5 days
3	Waiver*	3 working days

\* Associate is expected to raise the inspection call assuming that Inspection shall be carried out by TPCODL. The decision for waiver of inspection shall be on sole discretion of TPCODL.

### 13.2 Right to Rejection on Receipt

Goods/Material/Equipment delivered in condition physically damaged & incomplete as a product ordered, or not packed and transported as per the terms and conditions of the contract is liable to be rejected. Such item shall be lifted back by Associates within 15 days from receipt of rejection note from TPCODL and have to supply back the material within next 30 days or within the timeframe mutually decided by Associate and TPCODL.

If delivery of the material is beyond the agreed time, Liquidated damage clause, mentioned in this GCC separately shall be applicable; but the period for levy of LD shall be considered as per the original delivery schedule and not from the agreed timelines for material rectification.

### 13.3 Consignee

Unless otherwise specified in the Contract Document, Materials/Goods/Equipment shall be consigned to "Stores-In-Charge", TPCODL Bhubaneswar.

### 13.4 Submission of mandatory documents on Delivery

Doc. Title	GENERAL CONDITIONS OF CONTRACT - COMPOSITE WORKS	
Rev. No	0	Page 22 of 104

Following documents shall be mandatorily submitted by BA along with supply of material to TPCODL stores/site:

S. No.	Documents	Requisite
1	Invoice copy in original	With all consignments
2	LR copy	Wherever required
3	Packing list	With all consignments
4	MDCC	With all consignments
5	Purchase order / Release order	Signed copy
6	Test certificates	With all consignments
7	Inspection/JVR report	In case pre-dispatch inspection is conducted
8	Device data in CD as per template for metering items	Wherever applicable

### 13.5 Dispatch and Delivery Instructions

S. No.	Instructions
1	Purchase order/ Release order no. shall be mentioned on invoice and on material
2	TPCODL material code and material description shall be mentioned in invoice and on material.
3	"Property of TPCODL" shall be embossed on material.
4	The material shall be properly sealed and packed in standard packing as per purchase order terms & conditions.
5	The weight and quantity of material shall be mentioned wherever applicable
6	The material supplied shall be co-related with the packing list.
7	The name plate detail on equipment shall include Material code, Material description, specification detail of material [as applicable], Serial No. Year of manufacturing, PO/RO no. and date, "PROPERTY OF TPCODL, Bhubaneswar", Guarantee period and Associate's name.
8	In case of manual unloading, supplier / transporter shall deploy sufficient Labour for unloading the material at TPCODL central store. For heavy item(s), crane will be provided by TPCODL [unloading cost will be recovered from the associate].
9	The driver should have valid License and one helper in truck. All the documents of truck like registration papers, PUC etc should be available in Truck.
10	BA representative should accompany the material and get it unloaded / stacked in his presence wherever possible.

## 14.0 GUARANTEE

### 14.1 Guarantee of Performance

Associates shall stand guarantee that the equipment and material supplied/service or work rendered under the contract is free from design, manufacturing, material, construction, erection & installation and workmanship & quality defects and is capable of its due, rated and intended quality performance, as an integrated product delivered under the contract. for a specific period termed as Guarantee Period(as elaborated elsewhere in this clause) The

Doc. Title	GENERAL CONDITIONS OF CONTRACT - COMPOSITE WORKS	
Rev. No	0	Page 23 of 104

Associate should also guarantee that the equipment/material is new and unused except for the usage required for the tests and checks required as part of quality assurance.

#### **14.2 Guarantee Period**

The Guarantee Period will be equipment/service/work specific and shall be as specified in the Standard Specifications of TPCODL for the equipment/material/service/work and where standard specifications are not part of contract documents or guarantee period is not specified in the standard specifications,, the guarantee period shall be as per the Special Terms and Conditions of the Contract. In case of no mention of the guarantee period in standard specifications or SCC Guarantee Period will be 15 Months from the Date of Commissioning or 24 months from the date of delivery of final lot of supplies made, whichever is earlier.

#### **14.3 Failure in Guarantee Period (GP)**

If the equipment and material supplied/service or work rendered under the contract fails to perform its due, rated & intended quality performance, during the Guarantee period, the associate is liable to undertake repair/rectify/replace the equipment and material supplied/service or work rendered under the contract within time frame specified in the SCC or elsewhere in the contract documents at associate's cost to make the equipment and material supplied/service or work rendered under the contract of performing its due, rated and intended quality performance. If Associate fails to repair/rectify/replace the equipment or material supplied/service or work rendered under the contract, failed in Guarantee Period, TPCODL will be at liberty to get the same done at Associate's risks and costs and recover all such expenses plus the TPCODL's own charges (@ 20% of expenses incurred), from the Associate or from the "Security cum Performance Deposit" as the case may be.

If during the Warranty/ Guarantee period some parts of the supplies are replaced owing to the defects/ damages under the Warranty, the Warranty period for such replaced parts shall be until the expiry of twelve months from the date of such replacement or renewal or until the end of original Guarantee period, whichever is later.

Any repairs during the Guarantee Period shall be carried out by the Associate within 30 days of reporting the issue to Associate by TPCODL. However, if replacement of the Equipment is required, Associate shall notify the same to TPCODL within 7 days of reporting the issue by TPCODL. Thereafter, the total time for supply of new equipment/ material shall be equal to the original delivery period of that equipment/ material as specified in the Contract. In case the Associate is not able to rectify/ replace the faulty equipment/ material within the stipulated timelines as mentioned above, penalty shall be levied as per the Liquidated Damages clause mentioned in this document. The penalty amount shall be recovered from the payment due to the vendor or by encashment of the SPBG as the case may be.

#### **14.4 Cost of repairs on failure in GP**

The cost of repairs/rectification /replacement, apart from the actual cost of repairs/rectification/replacement is also inclusive of all associate costs of required transportation, site inspection /mobilization/dismantling and re-installation costs as applicable, to be borne by the Associate. The Associate has to ensure that the interruption in the usage of intended purpose of the equipment is minimized to the maximum extent In lieu of the time taken for repairs/rectification/replacement.

Doc. Title	GENERAL CONDITIONS OF CONTRACT - COMPOSITE WORKS	
Rev. No	0	Page 24 of 104

#### **14.5 Guarantee period for Goods Outsourced**

If the Associate outsources partly equipment/materials/services from third party as mutually agreed upon at the pre award stage of contract, TPCODL shall have the benefit of any additional guarantee period if provided by the third party for the part supplied/executed by them.

#### **14.6 Latent Defect**

Hidden defects in manufacturing or design of the product supplied and which could not be identified by the tests conducted but later manifested during operation of the equipment are termed as latent defects. Associates shall further be responsible for 'free replacement' for another period of THREE years from the end of the guarantee period for any 'Latent Defects' if noticed and reported by the Company.

#### **14.7 Support beyond the Guarantee Period**

The Associate shall ensure availability of spares and necessary support for a period of at least 10 years post completion of guarantee period of equipment supplied against the contract.

#### **15.0 LIQUIDATED DAMAGES**

Liquidated damages @1% of the total executed contract value per week or part thereof, for the period of delay in integrated completion, subject to maximum 10% of the value of the contract shall become leviable without prejudice to other rights of the TPCODL. This amount shall be recoverable from any amount due or becoming due to the Business Associates under this or any other contract. In specific cases, TPCODL reserves the right to apply LD only on the unexecuted portion of the supply and works for standalone use, provided full quantity is executed within a maximum 30% additional time. Deduction of LD shall be on landed cost i.e contract value inclusive of taxes and in pursuant statutory compliance GST would be applicable at the stipulated rate and the same shall be borne by Business Associate. In case of LD deduction, a GST invoice shall be issued by TPCODL as a proof of deduction/ recovery.

#### **15.1 LD Waiver Request**

Any request of LD waiver shall be submitted within thirty (30) days of deducting LD. Request submitted beyond the timeline shall not be entertained.

#### **15.2 Material Recovery**

In case of any recoveries for materials or services (for material free issued by TPCODL and not reconciled by BA or for services claimed and paid in excess at the time of running bills), the total cost which shall be recovered from the BA, shall be the gross amount of material or services (i.e. including taxes) plus applicable taxes as prevailing at the time of such recoveries.

#### **16.0 ASSIGNMENT OR SUBCONTRACTING**

Associates shall not assign/subcontract/outsourced the schedule of activities of contract TPCODL enters with the associate, in part or full, without TPCODL's prior written approval.



Doc. Title	GENERAL CONDITIONS OF CONTRACT - COMPOSITE WORKS	
Rev. No	0	Page 25 of 104

However outsourcing of materials/equipment/services by Associate to make the integrated product for which TPCODL's has placed the contract with the associate from suppliers, makes and agencies which have been mutually agreed upon during contract pre-award stage is permitted subject to following conditions.

In such cases where outsourcing is done by the Associate

- Shall ensure that outsourced suppliers comply with the technical and financial qualification requirements specified by TPCODL in the contract document
- Shall furnish all particulars about the proposed outsourcing agencies and the details of the goods/services/work outsourced to the Associate while seeking approval of TPCODL for inclusion for outsourcing. The Associate shall give approval or shall refuse approval in writing within thirty (30) days of receipt of such request. However the Associate shall not be entitled for any additional contract execution time whatsoever in lieu of the process for approval for outsourcing agencies, and shall be held responsible for any delay in the project execution time.
- Shall remain jointly and severally liable for any action, deficiency, and/or negligence on the part of his outsourcing agencies. The approval extended by the Associate to outsourcing agencies recommended by the Associate shall not discharge the later from his Contract obligations.

Shall submit to the Associate unpriced copies of purchase orders with technical specifications included in the orders, placed on outsourcing agencies as soon as the respective orders have been placed by the Associate.

## **17.0 UNLAWFUL ACTIVITIES**

The Associate shall have to ensure that none of its employees are engaged in any unlawful activities (whether covered under the scope of the present GCC or not) subversive of the TPCODL's interest failing which appropriate action (legal or otherwise) may be taken against the Associate by the TPCODL, in accordance with the terms of the present GCC.

## **18.0 CONFIDENTIALITY**

Associate and its employees or representatives thereof shall strictly maintain the confidentiality of various information they come across while executing the contract as detailed below.

### **18.1 Documents**

All maps, plans, drawings, specifications, schemes and other documents or information related to the Contract/Project and the subject matter contained therein and all other information given to the Associate by the TPCODL in connection with the performance of the contract shall be held confidential by the Associate and shall remain the property of the TPCODL and shall not be used or disclosed to third parties by the Associate for any purpose other than for which they have been supplied or prepared. The Associate may disclose to third parties, upon execution of confidentiality agreements, such part of the drawings, specifications or information if such disclosure is necessary for the performance of the Work provided such third parties agree in writing to keep such information confidential to the same extent and degree as provided herein, for the benefit of the TPCODL.

### **18.2 Geographical Data**

Doc. Title	GENERAL CONDITIONS OF CONTRACT - COMPOSITE WORKS	
Rev. No	0	Page 26 of 104

Maps, layouts and photographs of the unit/plant including its surrounding regions showing vital installation for national security of country or those of TPCODL shall not be published or disclosed to the third parties or taken out of the country without prior written approval of the TPCODL and upon execution of confidentiality agreements satisfactory to the TPCODL with such third parties prior to disclosure.

### **18.3 Associate's Processes**

Title to secret processes if any developed by the Associate on an exclusive basis and employed in the design of the equipment shall remain with the Associate. TPCODL shall hold in confidence such processes and shall not disclose such processes to the third parties without prior approval of the Associate and execution by such third parties of secrecy agreements satisfactory to the Associate prior to disclosure. Upon completion of contract, such processes shall become the property of the TPCODL. Title to technical specifications, drawings, flow sheets, norms, calculations, diagrams, interpretations of test results, schematics, layouts and such other information, which the Associate has supplied to the TPCODL under the Contract shall be passed on to the TPCODL. The TPCODL shall have the right to use these for construction, erection, start-up, Trial Run, operation, maintenance, modifications and/or expansion of the works including for the manufacture of spare parts.

### **18.4 Exclusions**

The provision of Clauses 16.1 to 16.3 shall not apply to information:

- Which at the time of disclosure are in the public domain which later on become part of public domain through no fault of the party concerned, or
- Which were in the possession of the party concerned prior to disclosure to him by the other party, or
- Which were received by the party concerned after the time of disclosure without restriction on disclosure or use, from a third party who did not acquire such information directly or indirectly from the other party or has no obligation of confidentiality for such information.

### **18.5 Violation**

In case of violation of this clause, the Associate is liable to pay compensation and damages as may be determined by the competent authority of TPCODL.

## **19.0 INTELLECTUAL PROPERTY RIGHTS**

If, in the course of performance of its functions and duties as envisaged by the scope of the present GCC, the Associate acquires or develops, any unique knowledge or information which would be covered, or, is likely to be covered within the definition of a trademark, copyright, patent, business secret, geographical indication or any other form of intellectual property right, it shall be obliged, under the terms of this present GCC, to share such knowledge or information with the TPCODL. All rights, with respect to, or arising from such intellectual property, as afore mentioned, shall solely vest in TPCODL.

Moreover, the Associate undertakes not to breach any intellectual property right vesting in a third party/parties, whether by breach of statutory provision, passing off, or otherwise. In the event of any such breach, the Associate shall be wholly liable to compensate, indemnify or make good any loss suffered by such third party/parties, or any compensation/damages

Doc. Title	GENERAL CONDITIONS OF CONTRACT - COMPOSITE WORKS	
Rev. No	0	Page 27 of 104

arising from any legal proceeding/s, or otherwise. No liability of TPCODL shall arise in this respect, and any costs, damages, expenses, compensation payable by TPCODL in this regard to a third party/parties, arising from a legal proceeding/s or otherwise, shall be recoverable from the Associate.

## 20.0 INDEMNITY

The Associate shall at all times indemnify, keep indemnified and hold harmless the TPCODL and its officers, directors, employees, affiliates, agents, successors and assigns against all actions, claims, demands, costs, charges and expenses arising from or incurred by reason of any infringement of patent, trade mark, registered design, copy rights and/or industrial property rights by manufacture, sale or use of the equipment supplied by the Associate whether or not the TPCODL is held liable for by any court judgement. In this connection, the TPCODL shall pass on all claims made against him to the Associate for settlement.

The Associate assumes responsibility for and shall indemnify and save harmless the TPCODL from all liability, claims, costs, expenses, taxes and assessments including penalties, punitive damages, attorney's fees and court costs which are or may be required to be paid by the TPCODL and its officers, directors, employees, affiliates, agents, successors and assigns arising from any breach of the Associate's obligations under the Contract or for which the Associate has assumed responsibilities under the Contract including those imposed under any local or national law or laws, or in respect to all salaries, wages or other compensation for all persons employed by the Associate or his Sub-Associates or suppliers in connection with the performance of any work covered by the Contract. The Associate shall execute, deliver and shall cause his Sub-Associate and suppliers to execute and deliver, such other further instruments and to comply with all the requirements of such laws and regulation as may be necessary there under to conform and effectuate the Contract and to protect the TPCODL.

The TPCODL shall not be held responsible for any accident or damages incurred or claims arising, due to the Associate's error there from prior to completion of work. The Associate shall be liable for such accidents and after completion of work for such accidents as the case may be due to negligence on his part to carry out Work in accordance with Indian laws and regulations and the specifications set forth herein.

## 21.0 LIABILITY & LIMITATIONS

### 21.1 Liability

Except for any specific liability which may be identified in the Contract and which may be payable hereunder, Associate shall not be liable for any special, incidental, indirect, or consequential Damages or any loss of business Contracts, revenues or other financial loss (or equivalents thereof no matter how claimed, computed or characterized) arising out of or in connection with the Performance of the Work or supply of Goods ***unless caused by Associate's negligence, willful misconduct or breach of contract.***

TPCODL shall have no liability or any special, incidental, indirect or consequential Damages for any loss of Business Contracts, revenues or other financial loss arising out of this Contract.

### 21.2 Limitation of Liability

Doc. Title	GENERAL CONDITIONS OF CONTRACT - COMPOSITE WORKS	
Rev. No	0	Page 28 of 104

The total liability of Associate against any contract shall be limited to the Total All Inclusive Contract Value.

## **22.0 FORCE MAJEURE**

Force Majeure applies if the performance by either Party ("the Affected Party") of its obligations under Contract is materially and adversely affected.

"Force Majeure" shall mean any event or circumstance or combination of events or circumstances referred below and their consequences that wholly or partly prevents or unavoidably delays any Party in the performance of its obligations under this Agreement, but only and to the extent that such events and circumstances are not within the reasonable control, directly or indirectly, of the Affected Party and could not have been avoided even if the Affected Party had taken reasonable care:

- Act of war (whether declared or undeclared), invasion, armed conflict or act of foreign enemy, embargo, blockade, revolution, riot, bombs, religious strife or civil commotion, etc.
- Politically motivated sabotage, or terrorism, etc.
- Action or Act of Government or Governmental agency for which remedy is beyond the control of the affected parties.
- Any act of God.

Note: Causes like power breakdown/ shortages/fire/strikes, accidents etc do not fall under Force Majeure.

Time being the essence of the Contract, if either party is prevented from the performance of its obligations in whole or in part due to an event of Force Majeure, then provided Notice of happening of any event by the Affected Party is given to the other party within seven (7) days from the date of occurrence of such event, which DIRECTLY has impact on works and submitted details and quantum of resulting effect, but at the same time had made all possible efforts to mitigate and overcome effects thereof, the Affected Party's performance under this Contract shall be suspended until such event ceases and the Scheduled Completion shall be delayed accordingly.

If Force Majeure event(s) continue for a period of more than three months, the parties shall hold consultation to discuss the further course of action.

Neither party shall be considered to be in default or in breach of its obligation under the Contract to the extent that performance of such obligation by either party is prevented by any circumstances of Force Majeure which arise after effective date of Contract.

Neither party can claim any compensation from the other party on account of Force Majeure.

## **23.0 SUSPENSION Of CONTRACT**

### **23.1 Suspension for Convenience**

TPCODL may, at any time and at its sole option, suspend execution of all or any portions of the schedule of items of contract to be supplied/work to executed by Associate under the contract by providing to the Associate atleast two business days written notice for contracts having contract completion period less than sixty days and atleast seven business days' notice for all other contracts.

Doc. Title	GENERAL CONDITIONS OF CONTRACT - COMPOSITE WORKS	
Rev. No	0	Page 29 of 104

Upon receipt of any such notice, the Associate shall respond as follows as applicable as per contract construction.

- Immediately discontinue further supply of material/goods specified in the suspension notice for supply contracts
- Immediately discontinue further service/work and supply of materials of those services/materials/work specified in the suspension notice for service /composite contract
- Promptly make every reasonable effort to obtain suspension, upon terms satisfactory to TPCODL, of all orders, outsourcing arrangements, and rental Contracts to the extent that they relate to performance of the portion of Work suspended by the notice.
- Protect and maintain the portion of the service/Work already completed, including the portion of the Work suspended hereunder, unless otherwise specifically stated in the notice.
- Continue delivering/carrying out the supply/service/work items as per contract conditions, which do not fall under purview of the suspension notice.

On receipt of resumption notice from TPCODL, the Associate shall resume execution of contract as specified in the resumption notice, within the time frame specified in the resumption notice,

### **23.2 Suspension for Breach of Contract conditions.**

TPCODL shall suspend execution of whole/or part thereof the contract till such time Associate complies with the conditions stipulated under section clause 27 for breach/default of contract conditions.

### **23.3 Compensation in lieu of Suspension**

If the suspension of the contract in whole or in part is for convenience of TPCODL and not due to any breach of contract conditions by the associate, TPCODL at its discretion shall consider compensating all reasonable additional costs incurred by Associate in lieu of suspension of whole or part of contract, on representation of the Associate providing justified estimates of such additional costs and such estimates are found acceptable and approved by competent authority of TPCODL.

If the suspension of contract in whole or part thereof is due to breach of contract conditions (refer clause 24.3) by the Associate, Associate shall not be entitled for any compensation for any cost incurred in lieu of suspension of whole or part of contract and also shall be liable for compensating all the losses arising to TPCODL in lieu of suspension of contract. Resumption notice shall be subject to the Associate taking corrective action for the breach of contract conditions within the time frame and as per the terms specified in the suspension notice.

## **24 TERMINATION OF CONTRACTS**

### **24.1 Termination for Default/Breach of Contract**

The contract / PO shall be subject to termination by TPCODL in case of breach of the contract by the Associate which shall include but not be limited to the following:

Doc. Title	GENERAL CONDITIONS OF CONTRACT - COMPOSITE WORKS	
Rev. No	0	Page 30 of 104

- a. Withdrawal or intimation by the Associate of its intent to withdraw or surrender the execution / completion of the contracted work /PO or failure in ensuring adherence to any delivery schedules, in deviation of the contract/ PO.
- b. Refusal or neglect on the part of the Associate to supply material/equipment of quantity or quality as specified by TPCODL and within the timeframe as specified in the contract document or refusal or neglect to execute the services/work in terms of the agreed standards of quantity or quality and/or within the timeframe specified in the contract/PO.
- c. Failure in any respect to perform any portion of the Work contracted with promptness, diligence, or in accordance with the terms of the contract.
- d. Failure to furnish guarantees as specified and /or failure to comply with the terms thereof.
- e. Failure to furnish such relevant documents or information within the time specified which may be necessary for due execution / completion of the works and documentation.
- f. Liquidation, bankruptcy either voluntary or involuntary OR entering into any composition or compromise with its creditors, or Insolvency.
- g. In case any reasonable information has been received by TPCODL that Associate has adopted/ or attempted to adopt any unethical conduct, action in award of the contract /PO or at any time thereafter.
- h. Failure to comply with applicable statutory provisions as contained in the contract or failure to comply with the applicable laws.
- i. Failure to comply with safety regulations/clauses stipulated in the contract or as may be generally instructed by TPCODL.

If the default or breach as specified under clause 24 (except sub clause g thereof) be committed by the associate for the first time, TPCODL shall issue, along the with notice of default or breach, a warning notice instructing the associate to take remedial/corrective action within the time frame stipulated in the warning notice and not to repeat the same in future. The timeframe for corrective action by the associate shall be specific to the nature of breach of contract and the same shall not be objected to by the Associate. If the Associate fails to comply with the instructions in the warning notice or in taking corrective action to the satisfaction of TPCODL then TPCODL may terminate the entire or part of contract at its discretion by issuing termination notice without incurring any liability on this ground.

In case the contract is terminated for any breach of the nature specified in clause 24 g stated above, TPCODL shall have the right to terminate all the contracts TPCODL is having with the Associate by issuing termination notice which shall be without prejudice to the other rights of TPCODL available to it under law.

Without prejudice to its right to terminate for breach of contract, TPCODL may, without assigning any reason, terminate the Contract in whole or in part at any time at its discretion while the contract is in force by serving a written notice of two weeks to the Associate.

In the event of TPCODL having proceeded with termination of the contract the associate shall comply and proceed further in the following manner:

- i) Associate shall discontinue the supply, on the expiry of the said period of two weeks.

Doc. Title	GENERAL CONDITIONS OF CONTRACT - COMPOSITE WORKS	
Rev. No	0	Page 31 of 104

ii) Associate shall ensure that no further steps are being taken towards discharge of the obligations, terms and conditions as contained in the contract/PO. This shall include initiation of actions not limited to discontinuation of other allied and associated arrangements which the associate might have entered into with third parties for due discharge of its obligations under the contract with TPCODL.

iii) The Associate shall perform thereafter such tasks as may be necessary to preserve and protect the terminated portion of the material/service/work in progress and the materials and equipment at TPCODL sites or in transit thereto. However the associate shall continue to fulfill its contractual obligations with regard to the part of contract not terminated.

iv) It shall be open for TPCODL to conduct a joint assessment with the associate of the material ,supplies, equipment ,works or in general as to the subject matter of the contract in regard to which the associate claims having completed its obligations before or during such termination.

v) It shall be open to TPCODL to seek invocation of the performance bank guarantee or any other guarantee or other security deposit by whatever name called submitted by the associate, which shall not be objected to or protested against by the associate.

In case of termination of the contract the parties agree to be governed inter alia by the following:

a) In case TPCODL exercises its right of termination as stated above the associate shall not dispute or object to the same.

b) The Associate shall be entitled to receive and claim only such payments OR sums of money from TPCODL as may be found payable to it in regard to works executed by it under the terms of the contract and no other claim of any nature whatsoever shall be made by the Associate.

c) All such provisions which the parties have agreed to survive and prevail even after termination of the contract shall remain effective despite the termination.

In the event of such termination, TPCODL may finish the Work by whatever method it may deem expedient, including the hiring of services and /or purchase of material equipment from such third parties as TPCODL may deem fit or may itself provide any labor or materials and perform any part of the Work. The associate undertakes to bear the incremental costs if any paid by TPCODL in such a case attributable to failure on the part of the associate. The Associate in such a case shall not be entitled to receive any further payments and any sums found payable to it may be adjusted by TPCODL against the amount recoverable from him on this ground. The same shall be without prejudice to other rights available to TPCODL under law against the associate.

Upon the termination of any of the contract due to occurrence of any circumstances provided in clauses stated above and constituting repeated breach or misconduct , TPCODL shall be entitled to bar the associates its agents , affiliates from undertaking any negotiation / tendering, bidding, participation activities concerning TPCODL for a period of two years from date of such termination. The same shall be without prejudice to other rights available to TPCODL.

## 24.2 Termination for convenience of Associate

Doc. Title	GENERAL CONDITIONS OF CONTRACT - COMPOSITE WORKS	
Rev. No	0	Page 32 of 104

Associate at its convenience may request for termination of contract, clearly assigning the reason for such request. TPCODL has full right to accept, reject or partially accept such request. This convenience will be available to associate only after one year from the contract effective date. For this purpose, associate will provide a notice period of 90 days to TPCODL, Associate will have to pay TPCODL a 'termination convenience fee' equivalent to 5% of unexecuted contract value.

### **24.3 Termination for Convenience of TPCODL**

TPCODL at its sole discretion may terminate the contract by giving 30 days prior notice in writing or through email to the Associate. TPCODL shall pay the Associate for all the supplies/ services rendered till the actual date of contract termination against submission of invoice by the Associate to that effect.

### **25.0 DISPUTE RESOLUTION & ARBITRATION**

In case of any dispute or difference the parties shall endeavor to resolve the same through conciliatory and amicable measures within 15 Days failing which the matter may be referred by either party for resolution by the sole arbitrator to be appointed mutually by both the parties. The arbitral proceedings shall be conducted in accordance with Arbitration and Conciliation Act 1996 and the place of arbitration shall be Bhubaneswar. The language to be used at proceedings shall be English and the award of the arbitrator shall be final and binding on the parties. The parties shall bear their respective costs of arbitration. The associate shall continue to discharge its obligations towards due performance of the works as per the terms of the contract during the arbitration proceedings unless otherwise directed in writing by TPCODL or suspended by the arbitrator. Further, TPCODL shall continue making such payments as may be found due and payable to the associate for such works.

#### **25.1 Governing law and jurisdiction**

The parties shall be subject to the jurisdiction of the courts of law in Bhubaneswar and any matter arising here from shall be subject to applicable law in force in India.

### **26.0 ATTRIBUTES OF GCC**

#### **26.1 Cancellation**

The Company reserves the right to cancel, add, delete at its sole discretion, all or any terms of this GCC or any contract, order or terms agreed between the parties in pursuance without assigning any reasons and without any compensation to the Associates.

#### **26.2 Severability**

If any portion of this GCC is held to be void, invalid, or otherwise unenforceable, in whole or part, the remaining portions of this GCC shall remain in effect.

#### **26.3 Order of Priority**

In case of any discrepancies between the stipulations in General Conditions of the Contract (GCC) and Special Conditions of Contract (SCC), the GCC shall stand superseded by the SCC to the extent stipulated hereinabove while balance portion of respective clauses of GCC shall continue to be applicable.

### **27.0 INSURANCE**



Doc. Title	<b>GENERAL CONDITIONS OF CONTRACT - COMPOSITE WORKS</b>	
Rev. No	0	Page 33 of 104

The Associate shall arrange accident insurance policy for his foreign experts/specialists/personnel deputed to Site and Associate's/his sub-Associates' manufacturing works as well as for his Indian engineers and supervisory staff. The Associate shall also take out for his Indian workmen, where applicable, a separate policy as required under Workmen's Compensation Act.

Associates shall be responsible to suitably insure their entire work-force (to the extent of at least meeting requirements under Workmen Compensation Act) Tools, Plant, Third party liability at the project site, All Risk comprehensive insurance for the entire works (insurance for free issue items will be in TPCODL scope) for total contract (PO/RO) value or any other such risks during execution of works, till the works are handed over to the company, in consultation with TPCODL and shall submit copies of such insurances to the Engineer-in-Charge for review / acceptance before commencing the work. Engineer-in-charge must ensure compliance to insurance requirement by Associate before commencement of works. TPCODL shall stand fully indemnified in this respect.

### **28.0 ERRORS AND OMISSIONS**

The Associate shall be responsible for all discrepancies, errors and omissions in the drawings, documents or other information submitted by him, irrespective of whether these have been approved, reviewed or otherwise accepted by the TPCODL or not. However any error in design/drawing arising out of any incorrect data/written information from TPCODL will not be considered as error and omissions on part of the Associate.

### **29.0 TRANSFER OF TITLES**

The title of ownership and property to all equipment, installations, erections, constructions materials, drawings & documents shall pass to the TPCODL after Commissioning and complete handing over-taking over.

However, such passing of title of ownership and property to the TPCODL shall not in any way absolve, dilute or diminish the responsibility and obligations of the Associate under this Contract including loss or damages and all risks, which shall vest with the Associate.

The Associate shall take all corrective measures arising out of discrepancies, errors and omissions in drawings and other information within the time schedule and without extra cost to the TPCODL.

The Associate shall also be responsible for any delay and/or extra cost if any, in carrying out engineering, and site works by other agencies arising out of discrepancies, errors and omissions stated in as well as of any late revision/s of drawings and information submitted by the Associate.

### **30.0 SUGGESTIONS & FEEDBACK**

We welcome all our Business Associates to write to us about their experience with TPCODL; be it our Company, our services or our people. Each and every concern, issue, query and suggestion from you will help us to become a better company to work with and shall help us develop a strong bonding of trust and a long term relationship with you.

You may send your feedback by filling up our Business Associate Feedback Form enclosed herewith as Annexure-I. You can also log on to our website [www.tpcentralodisha.com](http://www.tpcentralodisha.com) to provide your feedback according to the guidelines mentioned below:

Doc. Title	GENERAL CONDITIONS OF CONTRACT - COMPOSITE WORKS	
Rev. No	0	Page 34 of 104

### 31.0 CONTACT POINTS

In case Business Associate needs information with respect to payments or has any grievances, same may be lodged by log on to our website [www.tpcentralodisha.com](http://www.tpcentralodisha.com)

### 32.0 LIST OF ANNEXURES

S. No.	Subject	Annexure
1.	Performa for Bid Security Bank Guarantee	A
2.	Performa for Advance Payment Bank Guarantee	B
3.	Performa for Performance Bank Guarantee (CP cum EP)	C
4.	Performa for No Demand Certificate by Associate	D
5.	Performa for Indemnification on Statutory Compliance	E
6.	Performa For Application For Issuance of Consolidated TDS Certificate	F
7.	HR Service Level Agreement	G
8.	Under taking for competence of workmen	H
9.	Business Associate Feedback Form	I
10.	Acceptance Form For Participation In Reverse Auction Event	J
11.	NEFT or RTGS payment request form	K
12.	Contractor Safety Management System	L
13.	Vendor Appraisal Form	M
14.	Manufacturers Authorization Form	N



Doc. Title	GENERAL CONDITIONS OF CONTRACT - COMPOSITE WORKS	
Rev. No	0	Page 36 of 104

**ANNEXURE-B**

**PROFORMA FOR ADVANCE PAYMENT BANK GUARANTEE**

**(On Rs.100/- Stamp Paper)**

**Note:**

- (a) Format shall be followed in toto
- (b) Claim period of six months must be kept up
- (c) The guarantee to be accompanied by the covering letter from the bank confirming the signature to the guarantee

**TP Central Odisha Company Limited**  
**Bhubaneswar**

**Advance Payment B.G.No.....**

**Contract No.....dated.....**

1. You have entered into a Contract No \_\_\_\_\_ with M/s. \_\_\_\_\_ (hereinafter referred to as "the Vendor") for the supply and delivery of \_\_\_\_\_ (hereinafter referred to as" the said Equipment") for the price and on the terms and conditions contained in the said contract.
2. In accordance with the terms of the said contract, you have agreed to make an advance payment of Rs. \_\_\_\_\_ (Rupees \_\_\_\_\_ only) being \_\_\_\_\_% (\_\_\_\_\_percent) of the total value of the contract on "the Vendor" furnishing you with an irrevocable, unconditional and acceptable bank guarantee to be valid till the date of receipt of "the said equipment" covered by your above mentioned contract. For this purpose you have agreed to accept our guarantee.
3. In consideration thereof, we, \_\_\_\_\_ hereby irrevocably and unconditionally guarantee to pay to you on demand but in any case before the end of five working days from the date of the claim and without demur and without reference to "the Vendor" such amount or amounts not exceeding the sum of Rs. \_\_\_\_\_ (Rupees \_\_\_\_\_ only) being \_\_\_\_\_% (\_\_\_\_\_percent) of the total value of the contract on receipt of your intimating that "the Vendor" has not fulfilled his contractual obligations. You shall be the sole judge for such non-fulfillment and "the Vendor" shall have no right to question such judgment.
4. You shall have the right to file / make your claim on us under the guarantee for a further period of one months from the date of expiry.
5. This guarantee shall not be revoked without express consent and shall not be affected by your granting time or any other indulgence to "the Vendor", which shall include but

Doc. Title	GENERAL CONDITIONS OF CONTRACT - COMPOSITE WORKS	
Rev. No	0	Page 37 of 104

not be limited to, postponement from time to time of the exercise the same in you or any right which you may have against "the Vendor" and to exercise the same in any covenant contained or implied in the said contract or any other course or remedy or security available to you, and our Bank shall not be released from its obligations under this guarantee by your exercising any of your rights with reference to matters aforesaid or any of them or by reasons of any other act or forbearance or other acts of omission or commission on your part or any other indulgence shown by you or by any other matter or thing whatsoever which under the law would, but for this provision have the effect of relieving our bank from its obligation under this guarantee.

6. We also agree that you shall be entitled at your option to enforce this guarantee against our bank as a principal debtor, in the first instance, notwithstanding any other security or guarantee that you may have in relation to "the Vendor's" liabilities in respect of the premises
7. This guarantee shall not be affected by any change in the constitution of our Bank or "the Vendor" or for any other reason whatsoever.
8. Any claim / extension under the guarantee can be lodge-able at outstation banks or at Bhubaneswar branch and claim will also be payable at Bhubaneswar Branch **(to be confirmed by Bhubaneswar Branch by a letter to that effect)**
9. Notwithstanding anything herein contained, our liability under this guarantee is limited to Rs. \_\_\_\_\_  
(Rupees \_\_\_\_\_ only) and the guarantee will remain in force upto and including \_\_\_\_\_ (Date) and shall be extended from time to time for such period or period as may be desired by "the Vendor".
10. Unless a demand or claim under this guarantee is received by us in writing within one month from \_\_\_\_\_ (expiry date) i.e. on or before \_\_\_\_\_ (claim period end date), we shall be discharged from all liabilities under this guarantee thereafter.

Dated at \_\_\_\_\_ this \_\_\_\_\_ day of \_\_\_\_\_ 200\_\_\_\_\_

**Witness**

- |          |  |
|----------|--|
| 1. _____ | Bank's rubber stamp<br>Banks full address        |
| 2. _____ | Designation of Signatory<br>Bank official number |

Doc. Title	GENERAL CONDITIONS OF CONTRACT - COMPOSITE WORKS	
Rev. No	0	Page 38 of 104

**ANNEXURE- C**

**PROFORMA FOR PERFORMANCE BANK GUARANTEE (CP cum EP)**

**(On Rs.100/- Stamp Paper)**

**Note:**

- (a) Format shall be followed in toto
- (b) Claim period of one month must be kept up
- (c) The guarantee to be accompanied by the covering letter from the bank confirming the signature to the guarantee

-----  
-----  
**TP Central Odisha Company Limited**

**Bhubaneswar**

**CP cum EP BG No.....**

**Order/Contract No.....dated.....**

1. You have entered into a Contract No \_\_\_\_\_ with M/s. \_\_\_\_\_ (hereinafter referred to as "the Vendor") for the supply cum erection / civil work of \_\_\_\_\_ (hereinafter referred to as "the said Equipment") for the price and on the terms and conditions contained in the said contract.
2. In accordance with the terms of the said contract, "the Vendor" agreed to furnish you with an irrevocable, unconditional and acceptable bank guarantee for 10% of the value of contract and to be valid till the end of Guarantee period plus one month towards "Contract cum Equipment performance". For this purpose you have agreed to accept the guarantee.
3. In consideration thereof, we, \_\_\_\_\_ hereby irrevocably and unconditionally guarantee to pay to you on demand but in any case before the end of five working days from the date of the claim and without demur and without reference to "the Vendor" such amount or amounts not exceeding the sum of Rs. \_\_\_\_\_ (Rupees \_\_\_\_\_ only) being \_\_\_\_\_% (\_\_\_\_\_ percent) of the total value of the contract on receipt of your intimating that "the Vendor" has not fulfilled his contractual obligations. You shall be the sole judge for such non-fulfillment and "the Vendor" shall have no right to question such judgment.
4. You shall have the right to file / make your claim on us under the guarantee for a **further period of one month** from the date of expiry.
5. This guarantee shall not be revoked without express consent and shall not be affected by your granting time or any other indulgence to "the Vendor", which shall include but not be limited to, postponement from time to time of the exercise the same in you or any right which you may have against "the Vendor" and to exercise the same in any covenant contained or implied in the said contract or any other course or remedy or security

Doc. Title	GENERAL CONDITIONS OF CONTRACT - COMPOSITE WORKS	
Rev. No	0	Page 39 of 104

available to you, and our Bank shall not be released from its obligations under this guarantee by your exercising any of your rights with reference to matters aforesaid or any of them or by reasons of any other act or forbearance or other acts of omission or commission on your part or any other indulgence shown by you or by any other matter or thing whatsoever which under the law would, but for this provision have the effect of relieving our bank from its obligation under this guarantee.

6. We also agree that you shall be entitled at your option to enforce this guarantee against our bank as a principal debtor, in the first instance, notwithstanding any other security or guarantee that you may have in relation to "the Vendor's" liabilities in respect of the premises
7. This guarantee shall not be affected by any change in the constitution of our Bank or "the Vendor" or for any other reason whatsoever.
8. Any claim / extension under the guarantee can be lodge-able at outstation banks or at Bhubaneswar branch and claim will also be payable at Bhubaneswar Branch (to be confirmed by Bhubaneswar Branch by a letter to that effect in case BG is from the branch outside Bhubaneswar)
9. Notwithstanding anything herein contained, our liability under this guarantee is limited to Rs. \_\_\_\_\_ (Rupees \_\_\_\_\_) only and the guarantee will remain in force upto and including \_\_\_\_\_ (Date) and shall be extended from time to time for such period or period as may be desired by "the Vendor".
10. Unless a demand or claim under this guarantee is received by us in writing within one months from \_\_\_\_\_ (expiry date) i.e. on or before \_\_\_\_\_ (claim period end date), we shall be discharged from all liabilities under this guarantee thereafter.

Dated at \_\_\_\_\_ this \_\_\_\_\_ day of \_\_\_\_\_ 200\_\_

**Witness**

- |          |                          |
|----------|--------------------------|
| 1. _____ | Bank's rubber stamp      |
|          | Banks full address       |
| 2. _____ | Designation of Signatory |
|          | Bank official number     |

Doc. Title	GENERAL CONDITIONS OF CONTRACT - COMPOSITE WORKS	
Rev. No	0	Page 40 of 104

**ANNEXURE-D**

**PROFORMA FOR “NO DEMAND CERTIFICATE” BY ASSOCIATE**

(On Company’s Letter head or with Company Seal)

(To be submitted by the Associate to TPCODL Accounts Department at the time of receipt of full and final payment)

**(Certificate No. CCP/002)**

Name of the Project

Order/ Contract No.

Dated

Name of the Associate

Scheme No. / Job No.

We, M/s. \_\_\_\_\_ (Associate) do hereby acknowledge and confirm that we have received the full and final payment due and payable to us from TPCODL, in respect of our aforesaid Order No \_\_\_\_\_ dated \_\_\_\_\_ including amendments, if any, issued by TPCODL to our entire satisfaction and we further confirm that we have no claim whatsoever pending with TPCODL under the said contract / W.O.

Notwithstanding any protest recorded by us in any correspondence, documents, measurement books and / or final bills etc., we waive all our rights to lodge any claim or protest in future under this contract.

We are issuing this “NO DEMAND CERTIFICATE” in favour of TPCODL, with full knowledge and with our free consent without any undue influence, misrepresentation, coercion etc.

**Dated**

**Signature**

**Place**

**Name**

**Designation**

**(Company Seal)**



Doc. Title	GENERAL CONDITIONS OF CONTRACT - COMPOSITE WORKS	
Rev. No	0	Page 41 of 104

**ANNEXURE – E**

**PROFORMA FOR “INDEMNIFICATION ON STATUTORY COMPLIANCES”**

(To be submitted by the successful Bidder within seven days of award of work)

**(Certificate No. CCP/001)**

Name of the Project

Letter of Award / Contract No.

Dated

Name of the Associate

Scheme No. / Job No.

By this confirmation we, \_\_\_\_\_  
(Associate) are formally bound to M/s. TPCODL towards any sum which may be imposed, levied or hereinafter recovered by the Provident Fund Organization under the provisions of the Employees of the Provident Fund and Miscellaneous Provisions Act 1952 in respect of employees employed by us.

We well and truly bind ourselves and our heirs executors administrators and representatives jointly severally and respectively for the above payment only to be paid to M/s. TPCODL.

AND WHEREAS we, \_\_\_\_\_ (Associate) is making compliance of the Employees Provident Fund and Miscellaneous Provisions Act 1952, have entered into the above written bond for the indemnity to M/s. TPCODL against all losses from the acts or default of the said Associate in respect of compliance of the Provident Fund Act.

Similarly we hereby confirm that we have complied with all statutory and local laws and nothing is outstanding with regard to Local Sales Tax, Labour Laws, Local Municipal dues, Electricity dues etc. We have entered into the above written bond for the indemnity to M/s. TPCODL against all losses from the acts or default of the said Associate in respect of compliance of the Local Sales Tax Laws, Local Laws, Labour Laws, Local Municipal Dues, Electricity dues etc.

NOW THE CONDITION, of the above written bond is as such that if the Associate during the period of this contract commits any default or fails to make payment of Contributions in respect of his employees to the Employees Provident Fund Organization, he shall indemnify the Principal Employer M/s. TPCODL from all and every loss and damage caused to them from any act, omissions or negligence of the said Associate in respect of compliances under the Employees Provident Fund and Miscellaneous Provisions Act, 1952.

IN WITNESS to the above written bond we have here to set our hands, with our free consent.

**Dated**

**Place**

**Signature**

**Name**

**Designation (Company Seal)**

Doc. Title	GENERAL CONDITIONS OF CONTRACT - COMPOSITE WORKS	
Rev. No	0	Page 42 of 104

**ANNEXURE-F**

**PROFORMA FOR APPLICATION FOR ISSUANCE OF CONSOLIDATED TDS  
CERTIFICATE**

To be printed on the letterhead

To,

TP Central Odisha Company Limited,

Bhubaneswar

**Sub: Application for issuance of Consolidated TDS Certificate for the FY \_\_\_\_\_**

Dear Sir,

I / we hereby request / authorize you to issue me / us a consolidate TDS Certificate for the financial year \_\_\_\_\_ against tax deducted at source by you from my / our payments / bills during the said year from time to time under Chapter XVII – B of the Income Tax Act, 1961.

For and on behalf of

Signature

Name

Address

Contact No. (Land Line)

(Mobile)

PAN #

Assessing authority

**ATTACH THE COPY OF PAN CARD**

Doc. Title	GENERAL CONDITIONS OF CONTRACT - COMPOSITE WORKS	
Rev. No	0	Page 43 of 104

## **ANNEXURE - G**

### **SERVICE LEVEL AGREEMENT**

(To be adhered to by Business Associates (BAs) in TPCODL on Human Resource Issues)

**1.0 The following shall be adhered to by the Business Associates during his / its association with TPCODL:**

**Shall Abide by TPCODL Core Values:**

- a) **Integrity** – We must conduct our business fairly, with honesty and transparency. Everything we do must stand the test of public scrutiny.
- b) **Understanding** – We must be caring, show respect, compassion and humanity to our colleagues and customers and always work for the benefit of the communities we serve.
- c) **Excellence** – We must constantly strive to achieve the highest possible standards in our day to day work and in the quality of services we provide.
- d) **Unity** – We must work cohesively with our colleagues across the group and with our customers and partners to build strong relationships based on tolerance, understanding and mutual co-operation.
- e) **Responsibility** – We must continue to be responsible and sensitive to the communities and environments in which we work and always ensuring that what comes from the people; goes back to the people many times over.
- f) **Agility**- We must work in a speedy and responsive manner and be proactive and innovative in our approach.

**2.0 The Business Associate / his manager / supervisor who is responsible for managing the project site / performance contract etc. in TPCODL would also ensure adherence of these values by his employees / persons deployed by him in connection with his works undertaken in TPCODL.**

**3.0 TPCODL is a signatory to the United Nation Global Compact as an integral part of its Governance principles / business. The Business Associates are required to:**

- a) Support and respect the protection of human rights and make sure that they are not complicit in human right abuses.
- b) Respect freedom of association and effective recognition of the right to collective bargaining.
- c) Not to resort to any form of forced and compulsory labour.
- d) Shall ensure abolition of child labour in his area of work.
- e) There is no discrimination in respect of employment and occupation in respect of his employees.
- f) Support precautionary approach to environmental challenges.
- g) Promote greater environmental responsibility by himself and his employees in his areas of work.
- h) Deploy and defuse environmental friendly technologies while carrying out the works.
- i) Work against corruptions in all its form including extortion and bribery by himself and his employees.

**4.0 The Business Associates are required to adhere to all applicable Labour Laws with special reference to the following:**

Doc. Title	GENERAL CONDITIONS OF CONTRACT - COMPOSITE WORKS	
Rev. No	0	Page 44 of 104

- a) No person below the age of 18 years and no child labour will be engaged directly or indirectly for executing the work connected with the business of TPCODL.
- b) Minimum wages along with other statutory dues like PF, ESI, etc. as applicable to the workers shall be made within the prescribed period of 7<sup>th</sup> / 10<sup>th</sup> day of the following month.
- c) Deduction / deposit / record keeping and all other requirements under Employees PF Act 1952, Employees State Insurance Act 1948 and other applicable acts (if any) shall be adhered to.
- d) Only statutorily authorized deductions (if any) shall be made in accordance with the relevant statutes.
- e) All the provisions of Contract Labour (R&A) Act 1970 shall be complied with in respect of the workers engaged for TPCODL work. The work will be commenced only after completing necessary formalities for obtaining Labour License (if applicable).
- f) Necessary registers / records, filing of returns etc. shall be maintained for verification by Statutory / TPCODL authorities.
- g) Payment of wages shall be made only in presence of and with certification of authorized representative of TPCODL or shall be made in the form of cheque / bank transfer to the employee.
- h) During the period of contract, the Business Associate will arrange for deployment of his supervisor / manager for total supervision and control of the work and their manpower. All the activities related to their manpower e.g. attendance, leave, wage disbursement etc. will be done under the supervision & control of Business Associates, While adhering to the prescribed standard / norms of production / productivity & quality. During execution of the work, Business Associate shall engage only such qualified / skilled manpower as may be envisaged / required for ensuring level of production / service into the contract / work order.
- i) Clearances as follows shall be obtained from IR & Welfare Group:
  - i. Clearance for commencement (before start of the work).
  - ii. No Objection Certificate (after completion / before final settlement).
  - iii. Copies of PF / ESI Challans shall be deposited with IR & Welfare Group every month
- j) The Business Associate shall indemnify TPCODL from any liabilities under applicable Labour Statutes.
- k) The Business Associate shall ensure safety and health of his employees and shall also maintain hygienic working environment / condition in his area of work.
- l) The Business Associate and his employee shall abide by Laws of Land and shall not violate any applicable provisions.
- m) The Business Associate appreciates with and acquiesces to the right of TPCODL as principal employer to fulfil any of his legal obligations, if he fails to do so under applicable labour laws and deduct the same from his running bills / final payments / encashing security deposit / Bank Guarantee as the case may be. If there is any further shortfall TPCODL has the right to recover the same from the Business Associate.
- n) The Business Associate ensures that person employed by him adhere to the moral and legal conduct and shall not violate any standard conduct envisaged in the premise of

Doc. Title	GENERAL CONDITIONS OF CONTRACT - COMPOSITE WORKS	
Rev. No	0	Page 45 of 104

TPCODL by all such as, Transparency, Safety, Discipline, Integrity etc. The Business Associate or his employees should refrain from corrupt practices, giving or taking bribe in connection with any TPCODL business.

**5.0 The 'Statutory Compliance Enforcement System' in TPCODL is detailed below for adherence by all concerned. Corporate IR & Welfare Group will be the process owner for implementation of the system with the help of concerned Engineer I/c or Officer I/c.**

- a) Statutory Compliance being a professed value in TPCODL Code of Conduct, the concerned Engineer / Officer in charges are requested to adhere to the provisions and advise respective Business Associates in their domain to comply in letter and spirit.
- b) Immediately after issuance of letter of intent, the authorized representative of the Business Associate will report to Corporate IR & Welfare group for completion of statutory requirements.
- c) Normally, the work will be started only after 'Clearance for Commencement of Work (CCW)' is issued by IR & W group to the Business associate. However in exceptional exigencies in engineer I/c / Officer I/c may direct the Business Associate to start the work and inform IR & W group about the same. Statutory requirements in this case may be completed parallelly.
- d) First monthly bill will be released only after producing CCW to the finance department. Similarly closure of work and final settlement will be affected after issuance of no objection certificate from IR & W group.

**6.0 Requirements for 'Clearance for Commencement of Work' (CCW):**

- a) Submission of filled up Form 'A' for database (Annexure-1).
- b) Copy of PF Code allocation letter.
- c) Copy of ESI Code allocation letter.
- d) Submission of duly filled up Form IV CL(R&A) act (In case more than or equals to 20 workers during the period of contract).
- e) Submission of duly filled up Form VI A (Notice of Commencement).
- f) Copy of insurance cover note under WC Act 1923 (if applicable).
- g) Copy of Contract Agreement.
- h) Copy of indemnity bond (if applicable).
- i) Affidavit with regard to payment of wages through cheque / bank transfer only.

**7.0 Requirements during execution of work:**

- a) Copy of receipt of application for license / license (if applicable).
- b) Copy of PF Challan (latest by 26<sup>th</sup> day of every Month).
- c) Copy of ESI Challan (latest by 26<sup>th</sup> day of every Month).
- d) Copy of Wage disbursement sheet / Bank statement.
- e) Filing / Maintenance of all statutory registers / reports / returns for inspection by Statutory/ TPCODL authorities.
- f) Certification of wage disbursement by authorized representative of TPCODL.
- g) Copy of 'Labour Welfare Fund' deposit certificate / Challan.
- h) Insuring safe working practices at the work place.

**8.0 Requirements for 'No Objection Certificate' (NOC) for closure of work:**

- a) Submission of duly filled up Form VI A (Notice of Completion).

Doc. Title	GENERAL CONDITIONS OF CONTRACT - COMPOSITE WORKS	
Rev. No	0	Page 46 of 104

- b) Copy of Half yearly / Annual return for ESI / PF / CL(R&A).
- c) Consolidated copy of wage sheet of last month indicating full & final settlement of all dues like retrenchment benefit, bonus, leave encashment etc. Copy of individual declaration by employees in Form X regarding termination of employment.
- d) Confirmation certificate regarding filling up of form for transfer / withdrawal of PF by the concerned workers.

**In case any of the above are deviated / not complied with the Letter of Award/Order shall be liable to be withdrawn / cancelled.**

**Enclosure:**

- 1) Form A
- 2) Form X
- 3) Form XI
- 4) Form VI A
- 5) Form XXIV

GENERAL CONDITIONS OF CONTRACT

Doc. Title	GENERAL CONDITIONS OF CONTRACT - COMPOSITE WORKS	
Rev. No	0	Page 47 of 104

**FORM (A)**

**[To be submitted by the Business Associate to the Principal Employer within a week from LoA issuance]**

**A. Details of the Agency**

1. Name of Agency :
2. Nature of work :
3. Local Address with Ph.No. :  
(With Father's name) :
4. Permanent Address (Full) :
5. PF code no. & Place :
6. ESI Code no. & Place :
7. Name and address of :  
Sub-contractor (if any)

**B. Details of Work**

8. Name of work (as specified in LOI/LOA) :
9. LOI/LOA Nos. & Dates :
10. Period of contract (Specify Dates) :  
[Including Extension period, if any] :
11. Work Area [Department / Location] :
12. Name / Cell no. of Officer I/c :
13. Maximum No. of workers and staff to be engaged on any day during the year.
  - Supervisory Staff :
  - Workers :
14. Do you have any other contract in TPCODL : Yes/No  
If yes, furnish details:

15. Details of Workmen’s compensation Policy, if applicable

Name of Insurance Company .....  
 .....Policy No ..... Number of persons covered .....  
 Period of coverage: From ..... To .....

If no, I hereby undertake the liability arising out of Workmen’s Compensation Act and Rules made there under.

**C. Details of workers to be engaged**

**No. of Workers**

S. No.	Unskilled*	Semi-skilled*	Skilled*	Clerical / Supervisory

**\* Number to be indicated**

I/We shall fulfill all obligations arising from and under all relevant law in force from time to time. I/We undertake to keep the TPCODL indemnified against any loss or liability arising out of failure of my / our abiding the relevant laws.

The name of my / our representatives is ..... to enter the TPCODL Premises on my behalf.

**Date:**

**(Signature of the Business Associate  
 or his Authorized Representative)**

**This Business Associate is / will be engaged in TPCODL.**

**(Signature and seal of  
 Officer I/c of the Work)**



Doc. Title	GENERAL CONDITIONS OF CONTRACT - COMPOSITE WORKS	
Rev. No	0	Page 49 of 104

**Form X**

**Undertaking**

I \_\_\_\_\_ hereby undertake that all the dues in respect of my employment with M/s \_\_\_\_\_ for the period of \_\_\_\_\_ to \_\_\_\_\_ have been settled and final payments including retrenchment benefit have been made to me in full.

( \_\_\_\_\_ )

\_\_\_\_\_

Date:

GENERAL CONDITIONS OF CONTRACT

Doc. Title	GENERAL CONDITIONS OF CONTRACT - COMPOSITE WORKS	
Rev. No	0	Page 50 of 104

**Form XI**

**Undertaking**

With reference to the contract job awarded by M/s TP Central Odisha Company Limited to M/s \_\_\_\_\_ vide work order No. \_\_\_\_\_ dated \_\_\_\_\_

I \_\_\_\_\_ on behalf of

M/s \_\_\_\_\_ hereby undertake:

1. that the dues in respect of the workmen/ employee(s) engaged by us for the said contract, payable as per the provisions of relevant statute pertaining to

- i. wages/ salary
- ii. PF & ESI, Bhubaneswar Labour Fund
- iii. All other statutory obligation

has been paid /settled in full and no amount/ compliance is due/ pending.

2. That in case any dispute / claim is raised by the concerned workers i.r.o. any dues / payments, M/s \_\_\_\_\_ will settle the same on it's own and such liability will be borne by M/s \_\_\_\_\_

3. That M/s \_\_\_\_\_ hereby indemnify M/s TPCODL from any future liability i.r.o. any statutory obligation in respect of said contract.

Date:

\_\_\_\_\_  
( )  
Authorized Signatory

For M/s \_\_\_\_\_

Doc. Title	GENERAL CONDITIONS OF CONTRACT - COMPOSITE WORKS	
Rev. No	0	Page 51 of 104

**FORM- VI A**

**Notice for Commencement /Completion of contract work**

I/We, Sh. / M/s \_\_\_\_\_ (Name and Address of the Contractor) hereby intimate that the contract work \_\_\_\_\_ (name of work) in establishment of the \_\_\_\_\_ (name and address of the Principal Employer) for \_\_\_\_\_ which License No. \_\_\_\_\_ dated \_\_\_\_\_ has been issued to me/us by the Licensing Officer \_\_\_\_\_ (name of the Headquarters), has been commenced / completed with effect from \_\_\_\_\_ date / on date.

**Signature of Contractor**

**With Office Seal**

**The Inspector**

\_\_\_\_\_  
\_\_\_\_\_

**FORM XXIV**

[See Rule 82(1)]

***Return to be sent by the Contractor to the licensing Officer (in duplicate)***

Half -Yearly Ending \_\_\_\_\_

1. Name and address of the Contractor
2. Name and address of the Establishment
3. Name and address of the Principal Employer
4. Duration of Contract: From \_\_\_\_\_ to \_\_\_\_\_
5. No. of days during the half year on which
  - (a) the establishment of the principal employer had worked
  - (b) the contractor's establishment had worked
6. Maximum No. of contract labour employed on any day during the half -year:

Men	Women	Children	Total

7.
  - (i) Daily hours of work and spread over
  - (ii) (a) whether weekly holiday observed and on what day  
(b) if so, whether it was paid for
  - (iii) No. of man – hours of overtime worked

8. No. of man days worked by

Men	Women	Children	Total

9. Amount of wages paid

Men	Women	Children	Total

10. Amount of deductions from wages, if any

Men	Women	Children	Total

Whether the following have been provided –

- (i) Canteen : \_\_\_\_\_
- (ii) Rest rooms : \_\_\_\_\_

Doc. Title	GENERAL CONDITIONS OF CONTRACT - COMPOSITE WORKS	
Rev. No	0	Page 53 of 104

(iii) Drinking water : \_\_\_\_\_

(iv) Crèches : \_\_\_\_\_

(v) First Aid : \_\_\_\_\_

**Signature of contractor**

Place \_\_\_\_\_

Date \_\_\_\_\_

GENERAL CONDITIONS OF CONTRACT

Doc. Title	GENERAL CONDITIONS OF CONTRACT - COMPOSITE WORKS	
Rev. No	0	Page 54 of 104

**ANNEXURE – H**

**UNDERTAKING FOR COMPETENCE OF WORKMEN**

Name of Associate :

Tender No. :

Item :

With reference to the tender mentioned above, I/We \_\_\_\_\_,  
hereby undertake that the workmen/ employee(s) engaged by M/s  
\_\_\_\_\_ for the job against said tender shall be competent in all  
respect, commensurate to the nature of job.

Date:

\_\_\_\_\_  
( )

Authorized Signatory

For M/s

Seal

Doc. Title	GENERAL CONDITIONS OF CONTRACT - COMPOSITE WORKS	
Rev. No	0	Page 55 of 104

**ANNEXURE-I**

**BUSINESS ASSOCIATE FEEDBACK FORM**

With an objective to improve our internal processes and systems, and serve you better, we solicit your valuable feedback & suggestions. It is estimated that it will take about 10 minutes to complete this survey. We assure you that your feedback shall be kept confidential. Please send the duly filled feedback form in the "TPCODL addressed - attached envelop"

**You are associated with us as**

- OEMs       Service Contractor       Material Suppliers       Material & Manpower Supplier

**You are associated with us for**

- Less than 1 year       More than 1 year but less than 3 years       More than 3 years

**Your office is located at**

- Bhubaneswar / NCR       Within 200 kms from Bhubaneswar       More than 200 kms from Bhubaneswar

**Your nearly turnover with TPCODL**

- Less than 25 Lacs       25 Lacs to 1 Crore       More than 1 Cr.

**Additional information**

<b>Your Name</b>	
<b>Your Designation</b>	
<b>Your Organization</b>	
<b>Contact Nos.</b>	
<b>Email</b>	

*We once again thank you for your participation in this survey. Please spare 10 minutes to give your feedback on following pages (Section A to E)*

**SECTION - A**

(Please ✓ mark in the relevant box and give your remarks / suggestions / information for our improvement.).

S. No.	Parameters	1	2	3	4	5	Remarks/ Suggestion
		Do Not Agree	Slightly in Agreement	In Fair Agreement	Mostly in Agreement	Fully Agree	
1	You receive all relevant queries / tenders from us in timely manner.						
2	We provide you enough lead time to respond to our queries / tenders.						
3	We provide you adequate support (drawings, documents, clarifications, briefing etc.) to enable you meet our requirements.						
4	All following elements of our contract / purchase order are rational :						
4.1	Scope of Work						
4.2	Delivery / Execution Schedule						
4.3	Payment Terms						
4.4	Liquidated Damages						
4.5	Performance Guarantee						
5	Our purchase orders / contracts are simple, specific & easy to understand						
6	TPCODL demonstrate willingness to be flexible in administration of Contract / Purchase Order						
7	We provide timely responses / clarifications to your queries						
8	TPCODL representative you interact / coordinate with is adequately empowered to support you in meeting contractual obligations						
9	TPCODL provide you all necessary infrastructure support for timely and quality completion of work (including AMC)						
10	TPCODL Engineer-in-Charge timely certifies the jobs executed/ material supplied						



S. No.	Parameters	1	2	3	4	5	Remarks/ Suggestion
		Do Not Agree	Slightly in Agreement	In Fair Agreement	Mostly in Agreement	Fully Agree	
11	TPCODL Engineer-in-Charge efficiently supervises the job execution for timely completion of job						
12	BIRD (Bill Inward Receipt Desk) initiative has improved payment disbursement process						
13	Our approach for Inspection and Quality Assurance effective to expedite project completion?						
14	TPCODL never defaults on contractual terms						
15	In TPCODL Contracts closure is done within set time limit						
16	Our material receiving procedures are well defined and efficiently deployed to reduce mutual inconvenience						
17	Bank Guarantees are released in time bound manner						
18	Our processes related to payment / account settlement are effective.						
19	You get payments on time						
20	TPCODL Employees follow Ethical behaviour						

**SECTION - B**

(Please rate the following parameters on a scale of 1 to 5, where 1 - Minimum; 5 - Maximum)

SN	Parameters	1	2	3	4	5	Remarks/ Suggestion
1	How do you rate courtesy/ empathy/ attitude level and warmth of TPCODL employees you interact with from following team?						
1.1	Project Engineering						
1.2	District / Zones						
1.3	Projects/HOG (TS &P)						
1.4	Inspection & Quality Assurance						
1.5	Stores						
1.6	Metering & Billing						
1.7	Accounts / Finance						
1.8	Administration						
1.9	IT & Automation						
2	How would you rate TPCODL in comparison to your other clients in terms of <b>fairness of treatment and transparency</b> with its Business Associates?						
3	How would you rate TPCODL in comparison to your other clients in terms of <b>processes and systems to manage partnership</b> with its Business Associates						
4	How would you rate TPCODL in comparison to your other clients in terms of <b>building long term &amp; mutually relationship</b> with its Business Associates						

**SECTION-C**

Please ✓ mark in the relevant box and give your remarks / suggestions / information for our improvement.

SNo	Parameters	Certainly NO	Probably NO	Probably YES	Certainly YES	Remarks/ Suggestion
1	Based on your experience with TPCODL, would you like to continue your relationship with TPCODL?					
2	If someone asks you about TPCODL, would you talk "positively" about TPCODL?					
3	Would you refer TPCODL name to others in your community, fraternity and society as a professional & dynamic organization?					

**SECTION - D**

**If we ask you to rate us on a scale of 1 to 10, how will you rate TPCODL, that truly represents your overall satisfaction with us (please tick appropriate box) -**

1	2	3	4	5	6	7	8	9	10
---	---	---	---	---	---	---	---	---	----

Doc. Title	GENERAL CONDITIONS OF CONTRACT - COMPOSITE WORKS	
Rev. No	0	Page 60 of 104

### **SECTION – E**

Please ✓ mark in the relevant box and give your remarks / suggestions / information for our improvement.

Please spare your thoughts for TPCODL's improvement in particular areas of weaknesses, particularly relating to some great practices, attitudes that you have seen elsewhere in Indian and International Organizations, which you recommend TPCODL to adopt. Please give your valuable salient recommendations.

Please spare your thoughts for TPCODL's improvement in particular areas of major concerns for you. We also welcome your suggestions to adopt any best practices, attitudes that you have observed / experienced elsewhere in Indian/ International organization.

Recommendation	<i>Please tick (✓) your top 5 expectations out of the following 10 points listed below -</i>	
(Please list down improvement you expect from TPCODL)	<i>Timely payment</i>	
1	<i>Flexibility in Contracts/PO</i>	
	<i>Clarity in PO,s &amp; Contracts</i>	
2	<i>Timely response to quarries</i>	
	<i>Timely certification of works executed</i>	
3	<i>Clarity in Specs, drawings, other docs etc</i>	
	<i>Adequate information provided on website for tender notification, parties qualified etc.</i>	
4	<i>Timely receipt of material at site for execution</i>	
	<i>Performance Guarantee/EMD released in time</i>	
5	<i>Inspection &amp; quality assurance support for timely job completion</i>	

We thank you for your time and courtesy!!

Doc. Title	GENERAL CONDITIONS OF CONTRACT - COMPOSITE WORKS	
Rev. No	0	Page 61 of 104

## ANNEXURE-J

### ACCEPTANCE FORM FOR PARTICIPATION IN REVERSE AUCTION EVENT

***(To be signed and stamped by the bidder prior to participation in the auction event)***

In a bid to make our entire procurement process more fair and transparent, TPCODL intends to use the reverse auctions through SAP-SRM tool as an integral part of the entire tendering process. All the bidders who are found as technically qualified based on the tender requirements shall be eligible to participate in the reverse auction event.

**The following terms and conditions are deemed as accepted by the bidder on participation in the bid event:**

1. TPCODL shall provide the user id and password to the authorized representative of the bidder. *(Authorization Letter in lieu of the same shall be submitted along with the signed and stamped Acceptance Form).*
2. TPCODL will make every effort to make the bid process transparent. However, the award decision by TPCODL would be final and binding on the supplier.
3. The bidder agrees to non-disclosure of trade information regarding the purchase, identity of TPCODL, bid process, bid technology, bid documentation and bid details.
4. The bidder is advised to understand the auto bid process to safeguard themselves against any possibility of non-participation in the auction event.
5. In case of bidding through Internet medium, bidders are further advised to ensure availability of the entire infrastructure as required at their end to participate in the auction event. Inability to bid due to telephone line glitch, internet response issues, software or hardware hangs, power failure or any other reason shall not be the responsibility of TPCODL.
6. In case of intranet medium, TPCODL shall provide the infrastructure to bidders. Further, TPCODL has sole discretion to extend or restart the auction event in case of any glitches in infrastructure observed which has restricted the bidders to submit the bids to ensure fair & transparent competitive bidding. In case an auction event is restarted, the best bid as already available in the system shall become the start price for the new auction.
7. In case the bidder fails to participate in the auction event due any reason whatsoever, it shall be presumed that the bidder has no further discounts to offer and the initial bid as submitted by the bidder as a part of the tender shall be considered as the bidder's final no regret offer. Any offline price bids received from a bidder in lieu of non-participation in the auction event shall be outrightly rejected by TPCODL.
8. The bidder shall be prepared with competitive price quotes on the day of the bidding event.
9. The prices as quoted by the bidder during the auction event shall be inclusive of all the applicable taxes, duties and levies and shall be FOR at TPCODL site.
10. The prices submitted by a bidder during the auction event shall be binding on the bidder.
11. No requests for time extension of the auction event shall be considered by TPCODL.
12. The original price bids of the bidders shall be reduced on pro-rata basis against each line item based on the final all inclusive prices offered during conclusion of the auction event for arriving at Contract amount.

**Signature & Seal of the Bidder**



Doc. Title	GENERAL CONDITIONS OF CONTRACT - COMPOSITE WORKS	
Rev. No	0	Page 63 of 104

send payment information)

Name of the Authorized Signatory :

Contact Person's Name :

Official Correspondence Address :

We confirm that we will bear the charges, if any, levied by our bank for the credit of NEFT/RTGS amounts in our account. Any change in above furnished information shall be informed to TPCODL well in time at our own. Further, we kept TPCODL indemnified for any loss incurred due to wrong furnishing of above information.

Thanking you,

For \_\_\_\_\_

**(Authorized Signatory)**

**(Signature with Rubber Stamp)**

**Certification from Bank:**

We confirm that we are enabled for receiving NEFT/RTGS credits and we further confirm that the account number (specify Bank a/c no.) of (Please mention here name of the account holder), the signature of the authorized signatory and the MICR and IFSC Code of our branch mentioned above are correct.

This also is certified that the above information is correct as per Bank record

**(Manager's/ Officers Signature under Bank Stamp)**

**ANNEXURE-L**  
**CONTRACTOR SAFETY MANAGEMENT SYSTEM**

**1. OBJECTIVE**

The objective of the Contractor Safety Management System is to lay down clear guidelines for all Business Associates (including their associates, staff and agents) which would facilitate them to observe all statutory rules and regulations, comply with applicable standards of Central Electricity Authority (Measures relating to safety and electric supply) Regulations, 2010 & (safety requirements for construction, operation and maintenance of electrical plants and electric lines) Regulations, 2011, TPCODL Safety Manual and Guidelines and thus, ensure creation of safe working environment for all stakeholders of our network.

**2. SCOPE**

All contracts (minor and major) will be subject to the provisions of this document.

**Minor Contracts:** Contracts which satisfy all the criteria listed under the head "Minor Contracts".

**Major Contracts:** Contracts which satisfy any two or more criteria listed under the head "Major Contracts"

Criteria	Minor Contracts	Major Contracts
Value of Contract	< Rs. 1500000/- (less than Rs. Fifteen Lac)	>= Rs. 1500000/- (Equal or more than Rs. Fifteen Lac)
Period	Period less than 1 year	Any period
Working on energized electrical equipment	No	Yes
Working on height (above 1.8 Mtrs from ground)	No	Yes
Work involving construction activity	No	Yes
Working with hazardous goods or chemicals	No	Yes
Work involving danger to general public	No	Yes

**Note:** Exceptions for major and minor contract are – in house software development, supply of material or equipment but no direct or indirect installation of the same material, administration contracts (courier, water supply, printing, security, transport, etc.), minor civil work like plastering at ground level or flooring, etc. The facility management (housekeeping) contract will always be treated as a minor contract.



Doc. Title	GENERAL CONDITIONS OF CONTRACT - COMPOSITE WORKS	
Rev. No	0	Page 65 of 104

### 3. INFORMATION REQUIRED AT TIME OF VENDOR REGISTRATION OR BEFORE COMMENCEMENT OF CONTRACT

- 3.1 Business Associate is required to fill the Safety Management System Questionnaire as per *annexure 1* and submit along with the vendor registration process / bid / tender document. The filled questionnaire will be scrutinized by Engineer In-charge / indenting group and recommend suitability of the BA with respect to safety requirements. The fulfilment of statutory requirements for vendor registration pertaining to labour laws etc. shall be done by BA Cell on being referred to it.
- 3.2 Business Associate is required to take suitable risk control measures mentioned against the identified Hazards and Risk document provided for all contracts as per *annexure 2*. The primary objective of this is to evaluate the understanding of the BA towards risk mitigation and employment of safe work procedures. BA is required to conduct the Hazard identification and Risk Assessment study as per the procedure and deploy more or other measures if deemed necessary.
- 3.3 Business Associate shall comply with **Statutory Requirements related to Safety and Occupational Health** and submit the "Safety Undertaking" as per *annexure 4*.

### 4. GENERAL SAFETY CONDITIONS REQUIRED TO BE FULFILLED BY BUSINESS ASSOCIATES

The requirements of the contractor safety management system applicable to the minor or major contracts related to various groups are as following –

- 4.1 Maintenance of Distribution Network – *Annexure 3.1*
- 4.2 Distribution Projects – *Annexure 3.2*
- 4.3 EHV Projects – *Annexure 3.3*
- 4.4 Maintenance of Sub transmission network – *Annexure 3.4*
- 4.5 Civil / Generation Projects – *Annexure 3.5*
- 4.6 Meter Management Group (MMG), Revenue Recovery Group (RRG), Energy Auditing Group, AML, MRG, etc. – *Annex3.6*
- 4.7 Maintenance and Operation of Street Light. – *Annexure 3.7*

1. *Please note that hydra cranes used by any dept should be ACE Model No. FX 150 ACE SX 150, Escorts Model No. TRX 1550 or contemporary. Use of old generation hydra cranes like ACE 14XW or ACE 12 XW, etc are prohibited.*

**(Details as per Annexure attached)**

**Note:** *For minor contracts, the BA shall assign the duties of Safety Representative to the Work Supervisor. Work Supervisor will deliver all duties and responsibilities of Safety Supervisor as detailed in this document.*

The Business Associate (BA) having major contract will appointing Safety supervisor, engineer / manager for the TPCODL work. The BA shall make all necessary arrangements for getting their workforce safety trained and competency checked from the concerned official of TPCODL before deployment in the field. BA Cell shall recommend the suitability after competency checked by Engineer In-charge and SAFETY group (or his representative) of TPCODL. After getting the clearance from concerned official, BA cell and receiving temporary I-card issued by TPCODL, Business Associate shall commence the working.

Safety Representative of Business Associates will formally become the nodal point for safety concerns for TPCODL. **BA shall not frequently transfer or terminate the services of any of the safety representatives appointed for TPCODL work site. BA needs to ensure**

Doc. Title	GENERAL CONDITIONS OF CONTRACT - COMPOSITE WORKS	
Rev. No	0	Page 66 of 104

**that Safety representative is available at all points of time; failing which the work being carried out in the interim (period when Safety representative is not available) shall be treated as working under improper supervision and due penal provisions shall be initiated against the BA.** BA will be required to provide all applicable infrastructure and power to ensure smooth working of the safety representative to maintain a sound safety management system. **In all contracts safety representative will not be assigned any other activity at site apart from the works related to safety management. The duties are detailed in clause 5.5 of this document.** TPCODL will be auditing the facilities provided to the BA's safety team time to time.

The Safety Representative of the BA shall be required to meet and follow the instructions of the Engineer In-charge and SAFETY Group of TPCODL. He shall be responsible for providing the MIS and/or any other relevant information, as and when desired, within the stipulated time frame as per the requirements of TPCODL. Any non-conformance to safety will lead to the negative marking or issue of safety violation challan/ tokens which shall affect the monthly evaluation and performance of BA.

All contracts where BA has to depute vehicle for their staff and equipment to move from one location to other, the BA shall ensure that vehicle complies all required statutory clearances and requirement as per The Motor Vehicle Act, 1988 as well as TPCODL Road Safety Policy and are in good & safe state of working.

## **5. QUALIFICATION AND EXPERIENCE OF THE SAFETY AND SITE PERSONNEL**

Qualification and experience required for the safety and site personnel are as following:

**5.1 Safety Supervisor:** It is mandatory that educational qualification of safety supervisor be ITI (of relevant trade) / Diploma (Any branch of engineering) and he has a working experience on electrical system / relevant field of work at least 5 yrs for ITI and 3 years for Diploma holder. Having formal experience of the safety systems will be an added advantage

**5.2 Safety Engineer:** It is mandatory that educational qualification of safety engineer be at least Diploma (relevant branch) and he has working experience on electrical system of at least 3 yrs. Having the formal experience of the safety systems will be an added advantage.

**5.3 Safety Manager:** The educational qualification of safety manager should be graduate engineer with working experience on electrical system / network of at least 3 yrs. OR Diploma in Industrial Safety with working experience of 05 years including at least 02 years on electrical network.

However, clause 5.1, 5.2 and 5.3 are not applicable for minor contracts. In such cases, BA shall assign the duties of Safety Representative to the Work Supervisor. Work Supervisor will deliver required duties of Safety Representative (as per clause 5.5) in addition to other duties without diluting the importance of safety.

**5.4 Site Skilled Personnel:** For all responsibility related to site activities and operations, the BA shall employ only qualified and skilled persons and shall comply the provisions of section 19 & 29 of Central Electricity Authority (Measures relating to safety and electric supply) Regulations, 2010. Persons holding valid approvals only by any Government approved agency or a competency assessment panel or a team set up by TPCODL

Doc. Title	GENERAL CONDITIONS OF CONTRACT - COMPOSITE WORKS	
Rev. No	0	Page 67 of 104

shall be allowed to perform the High Risk / High Hazard activities (refer page 1). The skill / qualification required for the electrician and electrical supervisor are given in *annexure 5*. The contracts related to maintenance of Distribution Network, Distribution Projects, EHV Projects, maintenance of Sub-Transmission Network, MMG & EAG, maintenance and operation of street lights, shall preferably have at least 20 per cent of ITI qualified electricians in the first year of the contract. This figure shall preferably be incremented by 15 per cent every subsequent year.

*Note: For the competency assessment may please refer the work instructions. An employee shall have to necessarily undergo the competency assessment check once in every eighteen months.*

#### 5.5 Requirements from the Safety Representative(s) of the Business Associate:

- 5.5.1 Safety training of 2 hrs/employee/month and one day of safety induction training to all new employees joining the BA will be conducted by the BA as per Safety training modules of TPCODL.
- 5.5.2 Safety Talk / tool box talk before start of shift to BA employees.
- 5.5.3 Ensuring the availability & proper usage of the standard safety equipment (PPE)
- 5.5.4 Periodic inspection of PPE to ensure their serviceability and maintaining the 10% buffer stock of standard PPEs.
- 5.5.5 Ensuring the adherence to standard operating procedures of TPCODL as mentioned in TPCODL Safety standard and O & M and concerned function's manual.
- 5.5.6 Safety inspections / audits as per the process of TPCODL
- 5.5.7 Working in close coordination SAFETY Group of TPCODL.
- 5.5.8 Reporting of unsafe acts, unsafe conditions, near miss, incident or accident to Engineer In-Charge and SAFETY Group of TPCODL immediately after its occurrence.
- 5.5.9 Regular HIRA at site and comply the control measures as stated in the detailed HIRA as per the *annexure 2*. Also deployment of JSA based checklist shall be ensured.
- 5.5.10 Ensuring compliance with safety and other laws as may be applicable and providing for safety assurance.

#### 5.6 Training and Syllabus: The BA shall not deploy any person at work place / site or send newly recruited personnel directly to concerned official for competency assessment without Safety Induction Training.

5.6.1 All new BA employees have to necessarily undergo one and half days Safety training and Competency assessment at training centre of BA cell. This training will be conducted once in a week. After the completion of Safety training & Competency assessment I-card will be issued to all competent BA employees

5.6.2 BA is expected to initially train and judge the capability of the workman at his own end before further recommending the workmen for Competency assessment. If any BA workman sent for competency assessment. In case any BA workman fails in the Competency test at concerned official, it will be deemed that BA has not imparted sufficient training at his end and actual cost of training ₹ 7500/ BA employee/ failed attempt will be recovered.

5.6.3 The workers who have imparted Safety Training and issued I-Cards of TPCODL, are not deployed at TPCODL worksites/ voluntarily left the job by workers/ used somewhere else other than TPCODL by the BA, in that case Management reserves the rights to intervene and recover the actual cost of training i.e. ₹ 7500/BA employee. (*Exempted for attrition rate of BA workers less than or equal to 10% of total workforce deployed at TPCODL*)

Doc. Title	GENERAL CONDITIONS OF CONTRACT - COMPOSITE WORKS	
Rev. No	0	Page 68 of 104

5.7 It is desired that Safety representative of the BA to impart the general safety training to each employee of duration 2 hrs per month. The training will be organized at BA level and the record to be sent to engineer in-charge and SAFETY group of TPCODL every month. Please refer schedule and syllabus in *annexure 6*.

**List of Personal Protective Equipment (PPE) and Maintenance schedule:** BA shall commence the project or any work only when the required PPE are made available to the team of employees involved in the work. Each PPE of BA shall be checked / inspected by the safety representative / supervisor at zone before the work start or as prescribed in the list. Safety representative shall regularly check the healthiness of each PPE allocated to lineman. Suitable record shall be maintained at zone. Defective PPE shall be immediately replaced or within 24 hours by the BA. In no case linemen or any other official of BA may be allowed to work with defective PPE. It is preferred that BA ensures minimum stock of each PPE at zone for immediate replacement with defective one. The PPE shall be IS / BS / CE marked and exactly as per the standard or specification mentioned in the *annexure 7*. Working without PPE / non-standard PPE shall be treated as safety violation and penalty as stated in section 6.0 of this document. If TPCODL finds that BA has not provided the adequate / appropriate PPE to their staff, TPCODL reserves the rights to stop the work and call the BA to provide appropriate PPEs at the risk. If the BA fails to provide the required PPEs at the risk then the same shall be provided by TPCODL at the actual cost of the PPE. The amount shall be charged to BA and same shall be first recovered from the current bill of BA or any future payment to be made to BA. In the event of any balance amount still left for recovery, the same shall be adjusted against retention amount or by invoking bank guarantee submitted by BA.

**5.8 Safety Audit / Inspection & HIRA:** The BA shall get the required safety inspection / audit conducted by his technical team comprising of safety representative as per the *annexure 8*. The safety representative will be required to conduct the HIRA (Hazard Identification and Risk Assessment) as per *annexure 2* of the process and work undertaken at least two times in a year or every time if a new process / activity / machine is introduced or whenever an accident take place. The risk identified to be addressed suitably with –

- Engineering Control
- Management Control, and
- Personal Protective Equipment.

The safety representative of BA shall inform and educate for the identified risk and hazard control methods to employees, supervisor and engineer as well as the engineer in-charge and SAFETY group of TPCODL.

**5.9 Safety Performance and Safety MIS:** The BA shall maintain good practice of safety all through the contract duration. Safety shall always be of paramount importance during the contract period. Safety performance will be monitored on yearly basis throughout the period and no relaxation will be given for bad performance. BA with good track record and excellent performance will be rewarded suitably as per clause 6.0 of this document. The BA has to provide monthly "Performance Report – Safety" to engineer in-charge and SAFETY group TPCODL this shall be part of monthly bill along with training details. Performa of the report is enclosed as *annexure 9*.

**5.10 Pre – Employment Medical Check-up and Fitness of employees engaged for the critical works:** The BA shall submit the health fitness certificate for all those workers involved in climbing the pole or working at height for following diseases:

5.10.2 Epilepsy

- 5.10.3 Colour blindness
- 5.10.4 Deafness
- 5.10.5 Vertigo & height phobia

Every year BA will give an undertaking stating that all the employees are fit to work and have not developed aforesaid diseases. The Record of such medical check-ups shall be submitted to BA Cell before issue of temporary identity card. The records shall be maintained at BA Cell. All such medical check-ups shall be repeated once in a year for all workers involved in climbing the pole or working on electrical network.

## 6. REWARD AND PUNITIVE MEASURES

**6.1** To support the enforcement of good SHE & DM practices by the Business Associate and to eliminate repeated or continuing safety violations, use of appropriate reward and punitive measures shall be made. Each unsafe act or violation of the safety guidelines as described in the Safety Manual of the TPCODL will be audit criteria of this system. Broadly the measures identified are following:

- 6.1.1 Working without PPE/ Safety Gadgets
- 6.1.2 Working without proper tools and tackles, barricading, Poor condition of Crane / Hydra / Vehicle, using without certification / Licence, Incompetent driver/ Helper
- 6.1.3 Working without creation of effective safety zone
- 6.1.4 Improper Supervision at worksite, Lineman/ Supervisor working without competency
- 6.1.5 Working without adherence to PTW process or authorization/ not adherence to SOPs / W.I. of TPCODL.
- 6.1.6 Improper Working at height equal to or above 1.8 mtrs without taking proper fall protection measures/ Poor condition of Ladder

### 6.2 Measures of Reward and Punitive Measures

The Engineer In-Charge, NSO, SC, ASOs, CSI / SIs and SHE &DM group will conduct the surprise audits of the work / project and if any non-conformance is found the same will be booked and entered in the format "Safety Violation Record" *annexure 10*. The flow of the information is given below:

Safety Violation Escalation & Monitoring process	
Action	Responsibility
Safety Violation form has been filled and counter foil sent to SAFETY team for information. The main form is to be given to BA supervisor / Engineer in-charge. <i>(Automatically generated if Site audit done through Mobile App.)</i>	Engineer In-charge/ NSO / SC / SAFETY Group /CSI/ ASO/ Any authorised TPCODL official.
↓	
Entry of the violation in the master record and sending the information to concerned Manager, HoG, HoD, Head and Chief (O &S). <i>(Automatically generated if Site audit done through Mobile App.)</i>	SAFETY Group
↓	
Forwarding the information Centralized Account Payable (CAPS) for amount deduction from the current bill of the BA,	Engineer In-charge

<i>if any.</i>	
↓	
HoG (Safety – II) & HoG (Safety & Quality – Commercial) and CAPS to generate the MIS of the violations and the amount deducted.	SAFETY Group
↓	
The pool of the amount generated after the deduction to be utilized in safety welfare of BA employees.	SAFETY Group with approval of CFO/Chief (O & S) /CEO&MD

The safety violations have been rated from 1 to 5 (figure 6.3) as per the gravity of the violation. If the same violation is repeated it may escalate into a higher penalty. If a particular Business Associate employee violates safety norms three times, he shall not be allowed to work in TPCODL for a period of one year from the date of the 3<sup>rd</sup> violation.

### 6.3 Safety Violation Escalation Matrix

#### 6.3.1

Consequence of Safety Violation Observed (Not related to Incident/ Accident)		Violation				Subsequent Violations
S.No.	Safety Violation	1st	2nd	3rd	4th	
1	Working without PPE (Helmet/Gloves/Safety Harness/ Safety Shoes etc.)	A	B	C	D	Will attract the same penalty as applicable in the 4th violation.
2	Improper Working at Height	A	B	C	D	
3	Working without proper tools and tackles	A	B	C	D	
4	Poor condition of Crane/Hydra/ Vehicle/Incompetent driver/ Helper	A	B	C	D	
5	Violation of SOP/ WI	B	C	D	E	
6	Working without adherence to PTW process or authorization/ Safety Zone	C	D	E		
Legend	Action to be taken	Responsibility	Penalty Amount (in Rs.)		The number of violations are to be calculated cumulatively over the contract period and not on monthly basis.	
A	Warning letter	Engineer Incharge	Nil			
B	Levy of Penalty	Engineer Incharge	2,000			
C	Memo to BA & Levy of Penalty	Head of Group	4,000			
D	Memo to BA & Levy of Penalty	Head of Department	10,000			
E	Memo to BA, Levy of Penalty and termination of Contract	Head of Department	1,00,000			

Figure 6.3 (1a)-Penalty Matrix for Safety violation (Applicable for Minor Contracts)

Consequence of Safety Violation Observed (Not related to Incident/ Accident)		Violation				Subsequent Violations
S.No.	Safety Violation	1st	2nd	3rd	4th	
1	Working without PPE (Helmet/Gloves/Safety Harness/ Safety Shoes etc.)	B	C	D	D	Will attract the same penalty as applicable in the 4th violation.
2	Improper Working at Height	B	C	D	D	
3	Working without proper tools and tackles	A	B	C	D	
4	Poor condition of Crane/Hydra/ Vehicle/Incompetent driver/ Helper	B	C	D	E	
5	Violation of SOP/ WI	C	D	E		
6	Working without adherence to PTW process or authorization/ Safety Zone	C	D	E		
Legend	Action to be taken	Responsibility	Penalty Amount (in Rs.)		The number of violations are to be calculated cumulatively over the contract period and not on monthly basis.	
A	Levy of Penalty	Engineer Incharge	5,000			
B	Memo to BA & Levy of Penalty	Engineer Incharge	10,000			
C	Memo to BA & Levy of Penalty	Head of Group	25,000			
D	Memo to BA & Levy of Penalty	Head of Department	50,000			
E	Memo to BA, Levy of Penalty and termination of Contract	Head of Department	1,00,000			

Figure 6.3 (1b)-Penalty Matrix for Safety violation (Applicable for Major Contracts)

Once the BA reaches the “BLACK” (color – “5”) category, i.e. highest level of safety violation, “Termination” notice to BA will be issued from the office of the Head of Department (equivalent to Addl GM/ GM/ Sr. GM level) and further, *if required*, continuation / extension of contract will only be initiated by Functional Head of the department (equivalent to Sr. GM / VP level) and approved by CEO & MD. Till the extension, the contract will remain suspended.

TPCODL encourages the reportage of the safety violation during the contract work by BA. Any TPCODL employee can register a safety violation against the BA in the “Safety Violation Form” *annexure 10*. Initially the observer has to fill the form and handover the counterfoil (lower portion) of the document to the supervisor of the BA, inform the site engineer of TPCODL and send the top portion of the Safety Violation Form to SAFETY group for the further necessary action against the BA. **The cumulative nos. of Safety Violations pertaining to any particular BA shall be calculated on yearly basis.**

Safety violations resulting in incident / accident will be treated as per gravity of the injury / fatality and its impact as well as type i.e. minor or Major. Consequences of incident / accident are shown in the matrix (figure 6.3(2) for major and 6.3(3) for minor) below. In case of any accident, findings and recommendations of Accident Enquiry Committee will be final and binding and will supersede the arbitration clause of GCC.

Consequence Of an Incident / Accident (In case of <b>MAJOR</b> contract)		Incident / Accident				Action Required
Sl. No	Type of the injury	1st	2nd	3rd	4th	
1	Slight injury (First Aid Case)	<b>F</b> (Strengthening of process through continuous improvement in the work procedure)				Take risk reduction measures
2	Minor injury (No or Hospitalization less than 48 Hrs)	<b>F</b>	<b>G</b>	<b>G</b>	<b>H</b>	
3	Major injury (Bone injury or burn or Hospitalization more than 48 Hrs)	<b>G</b>	<b>G</b>	<b>H</b>	<b>I</b>	
4	Single fatality	<b>J</b>	<b>K</b>			Intolerable
5	Multiple fatalities (Two or more fatalities during one event)	<b>K</b>				
Legend	Action to be taken	Responsibility	Penalty (in Rs.)	<i>The number of violations are to be calculated cumulatively over the contract period and not on monthly basis.</i>		
<b>F</b>	Memo to BA and levy of penalty	Engineer Incharge	5,000/-			
<b>G</b>	Memo to BA and levy of penalty	Head of Group	20,000/-			
<b>H</b>	Memo to BA and levy of penalty	Head of Group	50,000/-			
<b>I</b>	Memo to BA and levy of penalty	Head of Department	2,00,000/-			
<b>J</b>	Memo to BA and levy of penalty	Head of Department	5,00,000/-			
<b>K</b>	Memo to BA, levy of penalty, termination of contract and black listing of BA	Functional Head	10,00,000/-			

**Figure 6.3 (2) - Penalty Matrix for Incident / Accident in Major Contracts**

(For example: In major contracts, if there is first incidence of major injury say bone injury (Cat. 3) where worker was hospitalized for more than 48 hrs then a penalty of amount Rs.20000/- will be deducted from the current bill produced for the payment. This penalty will be similar for first two incidents. However, it will increment to next higher category i.e. Rs. 50,000/- on subsequent incidents as per the above matrix)

Consequence Of an Incident / Accident (In case of <u>MINOR</u> contract)		Incident / Accident				Action Required
Sl. No	Type of the injury	1st	2nd	3rd	4th	
1	Slight injury (First Aid Case)	<b>L</b> (Strengthening of process through continuous improvement in the work procedure)				Take risk reduction measures
2	Minor injury (No or Hospitalization less than 48 Hrs)	<b>L</b>	<b>M</b>	<b>M</b>	<b>N</b>	
3	Major injury (Bone injury or burn or Hospitalization more than 48 Hrs)	<b>M</b>	<b>M</b>	<b>N</b>	<b>O</b>	
4	Single fatality	<b>P</b>	<b>Q</b>			Intolerable
5	Multiple fatalities (Two or more fatalities during one event)	<b>Q</b>				
Legend	Action to be taken	Responsibility		Penalty (in Rs.)		<i>The number of violations are to be calculated cumulatively over the contract period and not on monthly basis.</i>
<b>L</b>	Memo to BA and levy of penalty	Engineer Incharge		5,000/-		
<b>M</b>	Memo to BA and levy of penalty	Engineer Incharge		10,000/-		
<b>N</b>	Memo to BA and levy of penalty	Head of Group		25,000/-		
<b>O</b>	Memo to BA and levy of penalty	Head of Department		1,00,000/-		
<b>P</b>	Memo to BA and levy of penalty	Head of Department		3,00,000/-		
<b>Q</b>	Memo to BA, levy of penalty, termination of contract and black listing of the BA	Functional Head		5,00,000/-		

**Figure 6.3 (3) - Penalty Matrix for Incident / Accident in Minor Contracts**

(For example: In minor contracts, if a worker meets with a non-fatal accident say bone injury (Cat. 3) where he was hospitalized for more than 48 hrs then a penalty of amount Rs. 10,000/-, will be charged from the current bill produced for the payment. This penalty will be similar for first two incidents. However, it will increment to next higher category i.e. Rs. 25,000/- on subsequent incidents as per the above matrix.)

In case of single or multiple fatalities described under legends J&K of 6.3(2) and P&Q of 6.3(3), the concerned BA may be debarred from extension of contract or participate in new contract. In such event the approval of Chief (O & S) will be necessary for extension or award of new contract to concerned BA.

### 6.3.2 COMPENSATION FOR BA PERSONNEL

In the event of any untoward incident/ accident, the Business Associate shall ensure prompt medical assistance such as treatment, sickness benefit, etc. is provided to the victim(s) as per the Employees' Compensation Act, 1923 or Employees' State Insurance Act, 1948, as applicable. Also, the BA will be required to take adequate measures for compensating the victim(s) or his/her/their kin as follows:

#### I. For Death or Permanent / Total Disablement

The BA shall take an insurance coverage of at least Rs. 10 lakhs for each engaged employee, to cover any incidence of Death or Permanent / Total Disablement (Permanent/Total Disability shall be considered as defined under Employees' Compensation Act, 1923). In the event of any such unfortunate incident, the BA would ensure that adequate compensation is paid immediately to the family of the victim(s) from his own resources. This compensation shall be covered under the insurance policy subscribed by the BA mentioned earlier and the arrangement should be such that it would get reimbursed to the BA by the insurance agency subsequently.



Doc. Title	GENERAL CONDITIONS OF CONTRACT - COMPOSITE WORKS	
Rev. No	0	Page 73 of 104

## **II. For Permanent Partial Disablement and Temporary Total Disablement**

The compensation in this case will be as per provisions of the Employees' Compensation Act, 1923 or Employees' State Insurance Act, 1948, as applicable.

Accordingly, the BA shall obtain a suitable Insurance Policy on award of Contract and submit documentary evidence of the policy to the BA Cell before commencement of work. The BA shall ensure that the Insurance policy is active at all times and all employees are covered in all respects till the conclusion of contract period or till working with TPCODL. The BA shall submit a copy of the policy after periodic renewals to the BA Cell.

However, on occurrence of such unfortunate incident, if it is found that the victim(s) is/are not covered under any insurance policy, the BA shall be liable to pay the entire sum of Rs. 10 lakhs from his own resources.

Further, in case of an accident resulting in Death or Permanent / Total Disablement while on duty, the appointed BA Nodal Officer will ensure that the BA complies with all statutory provisions and benefits i.e. PF, Compensation, Gratuity etc., and that all these are made available to the employees' nominee(s) as per the stipulated timelines.

**6.3.3** TPCODL rewards the BA with good track record of safety management. It is proposed that BA complying with Contractors Safety Management, Safety Manual and Safety process will be rewarded suitably as per the procedure, rule and regulations of the TPCODL. In any case major accident is reported during an assessment period BA will not be eligible for this reward scheme. Assessment of contracts will be once in year. Generally the assessment cycle is calendar year and guidelines will be declared time to time.

### **Abbreviations Used in the Document**

TPCODL	TP Central Odisha Company Limited
BA	Business Associate
HIRA	Hazard Identification & Risk Assessment
JSA	Job Safety Analysis
EHV	Extra High Voltage
SAFETY	Safety, Occupation Health, Environment & Disaster Management
MMG	Meter Management Group
EAG	Energy Audit Group
PPE	Personal Protective Equipment
SOP	Standard Operating Procedures
CSI/SI	Circle Safety In-charge / Safety In-charge
ASO	Area Safety Officer
NSO	Nodal Safety Officer
SC	Safety Coordinator
HoG / HoD	Head of Group / Head of Department
AGM / GM / VP	Assistant General Manager / General Manager / Vice President

Doc. Title	GENERAL CONDITIONS OF CONTRACT - COMPOSITE WORKS	
Rev. No	0	Page 74 of 104

CFO / Chief (O & S)/ CEO & MD	Chief Finance Officer / Chief (Operating & Safety) / Chief Executive Officer & Managing Director
COS	Corporate Operation Services
CAP	Centralized Account Payable System
PTW	Permit To Work
GCC	General Conditions of Contract.

- END -

GENERAL CONDITIONS OF CONTRACT

Doc. Title	GENERAL CONDITIONS OF CONTRACT - COMPOSITE WORKS	
Rev. No	0	Page 75 of 104

**Annexure 1 (Refer Para 3.1)**

***Business Associate Safety Management System Questionnaire***

Certification					
The information provided in this questionnaire is a summary of the company's occupational health and safety management system.					
Company Name:					
Turnover and experience:		Name of top officer:			
Date:		Position			
Contract Details					
Contract Name			Contract Number:		
Business Associates Safety Management System Questionnaire		Marks	Yes	No	Score achieved
<i>Safety Policy and Management</i>					
- <b>Is there a written company Safety policy?</b>		1			
- If yes provide a copy of the policy, if No please refer Note 1.					
- <b>Does the company have an Safety Management system</b>		1			
- If yes provide details, if No please refer Note 1.					
- <b>Is there a company Safety Management System manual or plan?</b>		2			
- If yes provide a copy of the content page(s), if No please refer Note 1.					
- <b>Are Safety and occupational health responsibilities clearly identified for all levels of Management and staff?</b>		2			
- If yes provide details, if No please refer Note 1.					
<i>Safe Work Practices and Procedures</i>					
- <b>Has the company prepared safe operating procedures or specific safety instructions relevant to its operations and relevant work as per contract?</b>		1			
- If yes provide a summary listing of procedures or instructions, if No please refer Note 2.					

Certification				
- Comments				
- <b>Is there a register of injury or accident?</b> - If yes provide a copy (format)	1			
- <b>Is there a documented incident or accident investigation procedure?</b>  - If yes provide a copy of a standard incident report form, if No please refer Note 2.  - Comments	1			
<i>Safety Training</i>				
- <b>Describe how occupational health and safety training is conducted in your company</b>  If No please refer Note 1.	2			
- <b>Is a record maintained of all training and induction programs undertaken for employees in your company?</b>  - If yes provide examples of safety training records, if No please refer Note 2.	1			
- <b>Are regular safety inspections / audits are undertaken at worksites?</b>  -If yes provide details (formats), if No please refer Note 3.	1			
- <b>Is there a procedure by which employees can report hazards at workplaces?</b>  - If yes provide details if No please refer Note 1.	1			
<i>Safety Monitoring</i>				
- <b>Is there an officer / supervisor responsible for monitoring workplace / worksite safety?</b>	1			

Doc. Title	GENERAL CONDITIONS OF CONTRACT - COMPOSITE WORKS		
Rev. No	0	Page 77 of 104	

Certification				
- If yes provide details				
<i>Safety Performance Monitoring</i>				
- <b>Are employees regularly provided with information on company health and safety performance?</b> - If yes provide details	1			
- <b>Has the company ever been convicted of an occupational health and safety offence?</b> - If yes provide details	NO Marks (Negative mark ONE for each case)			
- Has there been any major accident of employee at TPCODL site in past	NO Marks (Negative mark ONE for each case)			
- Has there been any fatal accident of employee at TPCODL site in past. - (Note: Bid evaluation committee has to take cognizance of the incident and shall evaluate the bid only after formal approval of competent authority i.e. CTO. - In case of yes please refer Note 4.	NO Mark (Negative mark FIVE for each case)			
Minimum of 75% marks is required for qualification.		Total Marks achieved		
<i>Company Reference</i>				
1. Name of company 2. Name of company				

**Note**

1: If company does not have formal procedure on Safety Management System than vendor may submit proposed Safety road map along with safety action plan and brief safety policy on his letter head signed by head of the organization.

2: The vendor may submit the same in the Safety Action Plan.

3: The vendor may utilize the same format of TPCODL or on request SAFETY group will assist the vendor in developing the audit system. For other points also vendor may take the assistance of SAFETY group for development of Safety management system.

Doc. Title	GENERAL CONDITIONS OF CONTRACT - COMPOSITE WORKS	
Rev. No	0	Page 78 of 104

4: The vendor may submit the Safety Improvement Plan and Safety Action Plan for his employees based on following points.

- i. Action plan for enhancing safety awareness
- ii. Action plan for safety training of employee
- iii. Action plan for increasing safety audit in field
- iv. Action plan for provision and utilization of safety PPE.
- v. Action plan for fatality reduction.
- vi. Action plan for enhanced supervision at site
- vii. Action plan for making employee more responsible and accountable for safety.
- viii. Action plan for availability and utilization of all required tool and equipment.
- ix. Safety Improvement done in last two years, specially highlighting those which have been taken after the fatal accident along with results.
- x. Safety initiatives planed or started recently.
- xi. Any other point.

Based on above points and documentary evidences vendor will be required to submit a detailed report in support of his bid. The bid evaluation committee and competent authority will scrutinize the facts and the evidence submitted. If found satisfactory competent authority i.e. CTO may accord his approval for bid opening otherwise his tender shall be disqualified.

**Annexure 2 (Refer Para 3.2 and 5.8)**

***Risk Assessment Form***

Business Associate:
Scope of the work:
BA's Representative:
Telephone:
Signature:
Date:

Specific Task/Activity	Potential Hazards/Consequences	Class of Risk	Control Measures
Working at Height	Fall from height	2	<ol style="list-style-type: none"> <li>1. Mandatory usage of JSA checklist prior to start of work</li> <li>2. Use appropriate ladder</li> <li>3. Use full body safety harness having double lanyard.</li> <li>4. Use Electrical Safety Shoes if working on electrical network otherwise use safety shoes.</li> <li>5. Use Safety helmet.</li> <li>6. Use PPE as per the annexure 7 of this CSM document</li> <li>7. Refer Work instruction related to Working at Height for other details</li> <li>8. Use of metal scaffold to be ensured in height work (cup lock type)</li> <li>9. Deploy competent workforce who are medically fit</li> </ol>

Specific Task/Activity	Potential Hazards/Consequences	Class of Risk	Control Measures
Working on electrical equipment / network	Electric flash / electrocution	3	<ol style="list-style-type: none"> <li>1. Mandatory usage of JSA checklist prior to start of work</li> <li>2. Use Electrical Safety Shoes while working on electrical network.</li> <li>3. Use Electrical Safety gloves of appropriate voltage rating.</li> <li>4. Use face shield / visor attached with helmet.</li> <li>5. Use Safety helmet.</li> <li>6. Use PPE as per the annexure 7 of this CSM document</li> <li>7. Mandatory usage of Insulated tools &amp; tackles on electrical system</li> <li>8. Mandatory compliance for Lock Out &amp; Tag out system. Refer Work instruction related to Working on electrical equipment / network for other details</li> </ol>
Excavation / Civil work	Collapse of soil, Fall in excavated pit leading to Injury	2	<ol style="list-style-type: none"> <li>1. Use safety shoes.</li> <li>2. Use Safety helmet.</li> <li>3. Use PPE as per the annexure 7 of this CSM document</li> <li>4. Hard Barricading of the worksite.</li> <li>5. Refer Work instruction related to excavation / civil work for other details</li> </ol>
Material lifting & Mechanical Erection work	Fall of material/object, Topple of crane,	2	<ol style="list-style-type: none"> <li>1. Mandatory compliance of crane checklist</li> <li>2. Visual condition check of lifting tools and tackles such as wire rope sling, belt sling, chain, pulley block, D-shackles, etc. shall be ensured.</li> <li>3. The operator's physical fitness and alertness should be judged by sup. / EIC.</li> <li>4. Use PPE as per the annexure 7 of this CSM document</li> <li>5. Refer Work instruction related to Material lifting &amp; Mechanical Erection work</li> </ol>
Road Safety	Road Accidents	3	<ol style="list-style-type: none"> <li>1. Mandatory compliance of TPCODL Road Safety policy W07(COR-P-12)</li> </ol>



Doc. Title	GENERAL CONDITIONS OF CONTRACT - COMPOSITE WORKS	
Rev. No	0	Page 81 of 104

Specific Task/Activity	Potential Hazards/Consequences	Class of Risk	Control Measures
------------------------	--------------------------------	---------------	------------------

*Note: This information for the general indication purpose. The detailed risk assessment shall be conducted before start of the work by the authorized representative of the BA. The report of same shall be submitted to engineer in-charge along with annexure 4 of the CSM document.*

### Guidelines for filling the Risk Assessment Form

- *Specific Task/Activity* - The documentation of each major task associated with the contract.
- *Potential Hazards* - The identification of hazards associated with each activity or task to be carried out.
- *Class of Risk* - Each hazard should be evaluated as a level of risk, described as Risk Class 1, 2 or 3 defined above.
- *Control Measure* - The identification and documentation of actions required to eliminate or reduce the hazards that could lead to accident or injury.

Hazard / Risks shall be classified according to the following schedule:

- Class 1: Potential to cause injury treatable with first aid
- Class 2: Potential to cause death or permanent injury
- Class 3: Potential to cause more than one or more lost time injuries.

### Annexure 3.1 (Refer Para 4.0)

#### General Safety Conditions for the Maintenance of Distribution Network Contracts:

A BA awarded a contract (O&M) work of maintenance of distribution network will be required to fulfil the following conditions:

- BA shall provide Safety Policy and safety objectives of their company.
- BA shall comply with all statutory requirements like: applicable acts, regulations, codes of practice, OHSAS Standards, etc.
- BA shall provide the filled safety management questionnaire as per Annexure 1
- BA shall conduct a job risk assessment and provide information as per Annexure 2
- BA shall abide by Safety manuals, guidelines of TPCODL.
- BA shall provide its organisation structure & responsibilities in terms of Safety Management to TPCODL.
- BA shall document the work practices and procedures in terms of Safety Management.
- BA shall ensure safety training and induction program for the employees
- BA shall conduct safety audits & inspections as per TPCODL procedures provided by SAFETY group.
- BA shall provide and ensure the proper usage of the safety equipment (PPE) as per the TPCODL approved list in *annexure 7*.
- BA shall ensure periodic inspection of PPE to ensure its serviceability as per the specification given by TPCODL.
- BA shall ensure the adherence to standard operating procedures or guidelines laid down by TPCODL.
- BA shall ensure reporting of any unsafe act, unsafe conditions, near miss, incident or accident to engineer in-charge and SAFETY team of TPCODL.
- BA shall provide safety performance and Safety MIS (*annexure 9*) to engineer in-charge and SAFETY group periodically. Based on any non-confirmation to the safety procedures and guidelines, BA is liable to be negatively marked for his performance and suitable penalty will be imposed.
- BA shall ensure to depute a Safety Supervisor for managing a complete safety management system in a district. In case the BA has been awarded work in more than one district, then the following safety structure will be adopted.

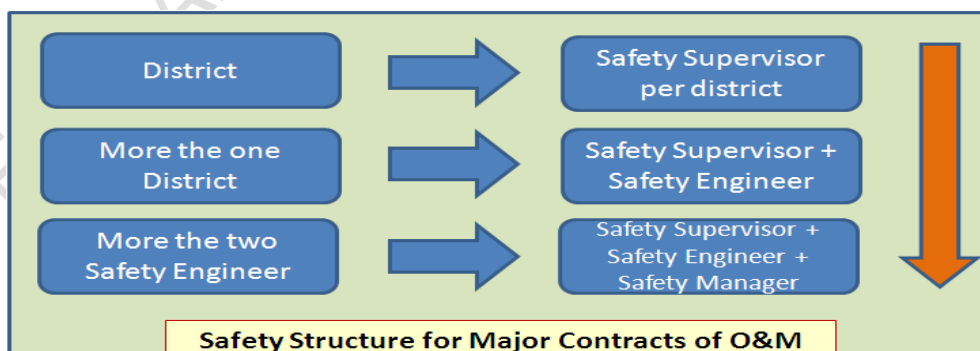

### Annexure 3.2 (Refer Para 4.0)

#### General Safety Conditions for the Distribution Projects Major Contracts:

A BA awarded a major contract work of TS&P in area of a circle will be required to fulfil the following conditions:

- BA shall provide Safety Policy and safety objectives of their company.
- BA shall comply with all statutory requirements like: applicable acts, regulations, codes of practice, OHSAS Standards, etc.
- BA shall provide the filled safety management questionnaire as per Annexure 1.
- BA shall conduct a job risk assessment and provide information as per Annexure 2
- BA shall abide by Safety manuals, guidelines of TPCODL.
- BA shall provide its organisation structure & responsibilities in terms of Safety Management to TPCODL.
- BA shall document the work practices and procedures in terms of Safety Management.
- BA shall ensure safety training and induction program for the employees
- BA shall conduct safety audits & inspections as per TPCODL procedures provided by SAFETY group.
- BA shall provide and ensure the proper usage of the safety equipment (PPE) as per the TPCODL approved list in annexure 7.
- BA shall ensure periodic inspection of PPE to ensure its serviceability as per the specification given by TPCODL.
- BA shall ensure the adherence to standard operating procedures or guidelines laid down by TPCODL.
- BA shall ensure reporting of any unsafe act, unsafe conditions, near miss, incident or accident to engineer in-charge and SAFETY team of TPCODL.
- BA shall provide safety performance and Safety MIS (*annexure 9*) to engineer in-charge and SAFETY group periodically. Based on any non-confirmation to the safety procedures and guidelines, BA is liable to be negatively marked for his performance and suitable penalty will be imposed.
- BA shall ensure to depute a Safety Supervisor for managing a complete safety management system in the area. In case the BA has been awarded work in more than one circle, then the following safety structure will be adopted.

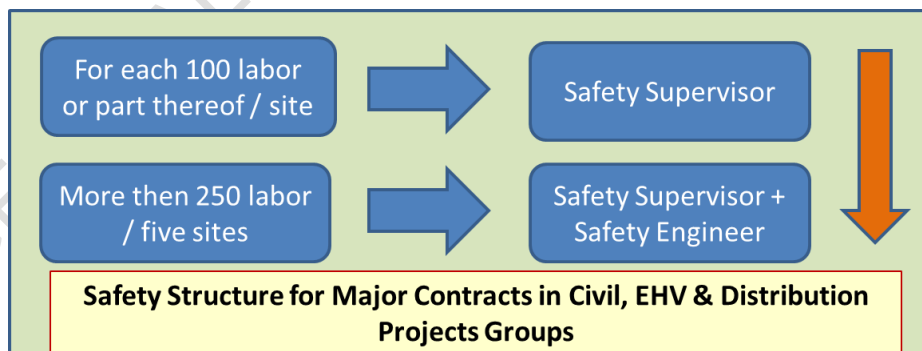

### Annexure 3.3 (Refer Para 4.0)

#### General Safety Conditions for the major EHV Projects Contracts:

A BA awarded a major contract work of EHV projects will be required to fulfil the following conditions:

- BA shall provide Safety Policy and safety objectives of their company.
- BA shall comply with all statutory requirements like: applicable acts, regulations, codes of practice, OHSAS Standards, etc.
- BA shall provide the filled safety management questionnaire as per Annexure 1
- BA shall conduct a job risk assessment and provide information as per Annexure 2
- BA shall abide by Safety manuals, guidelines of TPCODL.
- BA shall provide its organisation structure & responsibilities in terms of Safety Management to TPCODL.
- BA shall document the work practices and procedures in terms of Safety Management.
- BA shall ensure safety training and induction program for the employees
- BA shall conduct safety audits & inspections as per TPCODL procedures provided by SAFETY group.
- BA shall provide and ensure the proper usage of the safety equipment (PPE) as per the TPCODL approved list in annexure 7.
- BA shall ensure periodic inspection of PPE to ensure its serviceability as per the specification given by TPCODL.
- BA shall ensure the adherence to standard operating procedures or guidelines laid down by TPCODL.
- BA shall ensure reporting of any unsafe act, unsafe conditions, near miss, incident or accident to engineer in-charge and SAFETY team of TPCODL.
- BA shall provide safety performance and Safety MIS (*annexure 9*) to engineer in-charge and SAFETY group periodically. Based on any non-confirmation to the safety procedures and guidelines, BA is liable to be negatively marked for his performance and suitable penalty will be imposed.
- BA shall ensure to depute a Safety Supervisor for managing a complete safety management system in the area. In case the BA has been awarded work in more than one circle, then the following safety structure will be adopted.
- BA shall refer Construction Safety Manual in TPCODL Safety Manual for details.

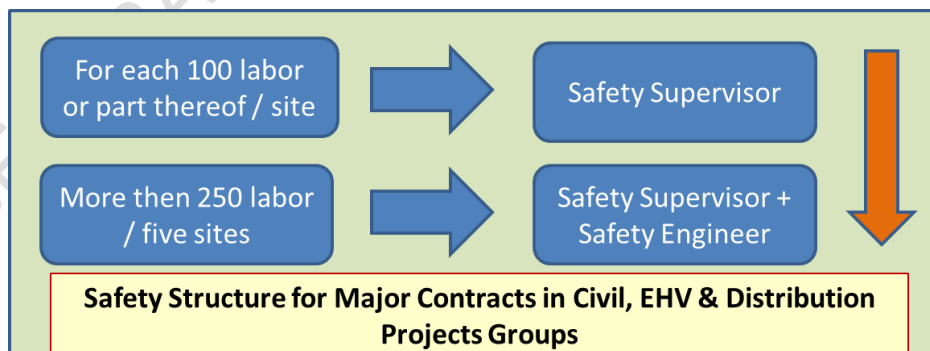

**Annexure 3.4 (Refer Para 4.0)**

**General Safety Conditions for the Maintenance of Sub – Transmission Network Contracts:**

A BA awarded a major contract work of maintenance of sub – transmission network in area of a power system will be required to fulfil the following conditions:

- BA shall provide Safety Policy and safety objectives of their company.
- BA shall comply with all statutory requirements like: applicable acts, regulations, codes of practice, OHSAS Standards, etc.
- BA shall provide the filled safety management questionnaire as per Annexure 1
- BA shall conduct a job risk assessment and provide information as per Annexure 2
- BA shall abide by Safety manuals, guidelines of TPCODL.
- BA shall provide its organisation structure & responsibilities in terms of Safety Management to TPCODL.
- BA shall document the work practices and procedures in terms of Safety Management.
- BA shall ensure safety training and induction program for the employees
- BA shall conduct safety audits & inspections as per TPCODL procedures provided by SAFETY group.
- BA shall provide and ensure the proper usage of the safety equipment (PPE) as per the TPCODL approved list in annexure 7.
- BA shall ensure periodic inspection of PPE to ensure its serviceability as per the specification given by TPCODL.
- BA shall ensure the adherence to standard operating procedures or guidelines laid down by TPCODL.
- BA shall ensure reporting of any unsafe act, unsafe conditions, near miss, incident or accident to engineer in-charge and SAFETY team of TPCODL.
- BA shall provide safety performance and Safety MIS (*annexure 9*) to engineer in-charge and SAFETY group periodically. Based on any non-confirmation to the safety procedures and guidelines, BA is liable to be negatively marked for his performance and suitable penalty will be imposed.
- BA shall ensure to depute a Safety Coordinator for managing a complete safety management system in the area. In case the BA has been awarded work in more than one area power system, then the following safety structure will be adopted.



### Annexure 3.5 (Refer Para 4.0)

#### General Safety Conditions for the major contract work in Civil / Generation Projects:

A BA awarded a major contract work of / in civil or Generation project will be required to fulfil the following safety conditions:

- BA shall provide Safety Policy and safety objectives of their company.
- BA shall comply with all statutory requirements like: applicable acts, regulations, codes of practice, OHSAS Standards, etc.
- BA shall provide the filled safety management questionnaire as per Annexure 1
- BA shall conduct a job risk assessment and provide information as per Annexure 2
- BA shall abide by Safety manuals, guidelines of TPCODL.
- BA shall provide its organisation structure & responsibilities in terms of Safety Management to TPCODL.
- BA shall document the work practices and procedures in terms of Safety Management.
- BA shall ensure safety training and induction program for the employees
- BA shall conduct safety audits & inspections as per TPCODL procedures provided by SAFETY group.
- BA shall provide and ensure the proper usage of the safety equipment (PPE) as per the TPCODL approved list in annexure 7.
- BA shall ensure periodic inspection of PPE to ensure its serviceability as per the specification given by TPCODL.
- BA shall ensure the adherence to standard operating procedures or guidelines laid down by TPCODL.
- BA shall ensure reporting of any unsafe act, unsafe conditions, near miss, incident or accident to engineer in-charge and SAFETY team of TPCODL.
- BA shall provide safety performance and Safety MIS (*annexure 9*) to engineer in-charge and SAFETY group periodically. Based on any non-confirmation to the safety procedures and guidelines, BA is liable to be negatively marked for his performance and suitable penalty will be imposed.
- BA shall ensure to depute a Safety Supervisor (for workforce upto 100 at site) / a safety engineer (for workforce upto 250 at site) / safety manager (for more than two safety engineers) for managing a complete safety management system at the project site. In case the BA has been awarded more than one major contracts, then the following safety structure will be adopted.
- BA shall refer Construction Safety Manual in TPCODL Safety Manual for details.



Doc. Title	GENERAL CONDITIONS OF CONTRACT - COMPOSITE WORKS	
Rev. No	0	Page 87 of 104

**Annexure 3.6 (Refer Para 4.0)**

**General Safety Conditions for the major contract work in Commercial Department like - MMG, RRG, EAG, etc.:**

A BA awarded a major contract work in meter management group & energy auditing group will be required to fulfil the following safety conditions:

- BA shall provide Safety Policy and safety objectives of their company.
- BA shall comply with all statutory requirements like: applicable acts, regulations, codes of practice, OHSAS Standards, etc.
- BA shall provide the filled safety management questionnaire as per Annexure 1
- BA shall conduct a job risk assessment and provide information as per Annexure 2
- BA shall abide by Safety manuals, guidelines of TPCODL.
- BA shall provide its organisation structure & responsibilities in terms of Safety Management to TPCODL.
- BA shall document the work practices and procedures in terms of Safety Management.
- BA shall ensure safety training and induction program for the employees
- BA shall conduct safety audits & inspections as per TPCODL procedures provided by SAFETY group.
- BA shall provide and ensure the proper usage of the safety equipment (PPE) as per the TPCODL approved list in annexure 7.
- BA shall ensure periodic inspection of PPE to ensure its serviceability as per the specification given by TPCODL.
- BA shall ensure the adherence to standard operating procedures or guidelines laid down by TPCODL.
- BA shall ensure reporting of any unsafe act, unsafe conditions, near miss, incident or accident to engineer in-charge and SAFETY team of TPCODL.
- BA shall provide safety performance and Safety MIS (*annexure 9*) to engineer in-charge and SAFETY group periodically. Based on any non-confirmation to the safety procedures and guidelines, BA is liable to be negatively marked for his performance and suitable penalty will be imposed.
- BA shall ensure to depute a Safety Supervisor for managing a complete safety management system for the work as per the following safety structure.
- The BA for the RRG work shall depute one Safety supervisor.

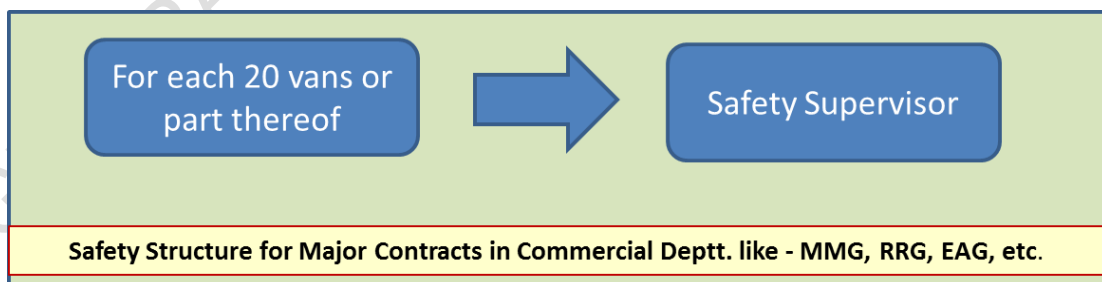



**Annexure 3.7 (Refer Para 4.0)**

**General Safety Conditions for the major contract work in O&M of street light group:**

A BA awarded a major contract work in operation and maintenance of street light group will be required to fulfil the following safety conditions:

- BA shall provide Safety Policy and safety objectives of their company.
- BA shall comply with all statutory requirements like: applicable acts, regulations, codes of practice, OHSAS Standards, etc.
- BA shall provide the filled safety management questionnaire as per Annexure 1
- BA shall conduct a job risk assessment and provide information as per Annexure 2
- BA shall abide by Safety manuals, guidelines of TPCODL.
- BA shall provide its organisation structure & responsibilities in terms of Safety Management to TPCODL.
- BA shall document the work practices and procedures in terms of Safety Management.
- BA shall ensure safety training and induction program for the employees
- BA shall conduct safety audits & inspections as per TPCODL procedures provided by SAFETY group.
- BA shall provide and ensure the proper usage of the safety equipment PPE as per the TPCODL approved list in annexure 7.
- BA shall ensure periodic inspection of PPE to ensure its serviceability as per the specification given by TPCODL.
- BA shall ensure the adherence to standard operating procedures or guidelines laid down by TPCODL.
- BA shall ensure reporting of any unsafe act, unsafe conditions, near miss, incident or accident to engineer in-charge and SAFETY team of TPCODL.
- BA shall provide safety performance and Safety MIS (*annexure 9*) to engineer in-charge and SAFETY group periodically. Based on any non-confirmation to the safety procedures and guidelines, BA is liable to be negatively marked for his performance and suitable penalty will be imposed.
- Each BA shall ensure to depute a Safety Supervisor for managing a complete safety management system for the work awarded as per the below structure.





Doc. Title	GENERAL CONDITIONS OF CONTRACT - COMPOSITE WORKS	
Rev. No	0	Page 89 of 104

### **Annexure 4 (Refer Para 3.3)**

#### **Safety Undertaking by way of Affidavit**

I \_\_\_\_\_ s/o \_\_\_\_\_ R/o \_\_\_\_\_ (AUTHORIZED REPRESENTATIVE/PARTNER/DIRECTOR/PROPRIETOR ) of M/S \_\_\_\_\_(name of company/firm)\_\_\_ having its office at (Complete address of Company), authorized vide power of attorney dated -----/Board resolution dated----/letter of authority dated----, hereinafter referred to as **Contractor [or Business Associate (BA)]** which expression shall, unless it be repugnant to or inconsistent with the meaning or context thereof, be deemed to include its heirs, executors, administrators, and assigns do hereby affirm and undertake as under :

1. The present undertaking shall remain in force from the date of execution of contract awarded by TPCODL and shall be valid till the date of termination of the said contract by either parties. The undertaking is binding on me (contractor) as well as my sub-contractor and its employees, representatives etc.
2. That I(the contractor) will be responsible and liable to comply and abide by all the safety rules, instructions and regulations as may be specified and laid down by The TP Central Odisha Company Limited (TPCODL) so as enable TPCODL to achieve its goal of Zero On site incidences.
3. That the Contractor shall be fully responsible for ensuring occupational health and safety of its employees, representatives, agents as well as of its subcontractor's employees, at all times during the discharge of their respective obligations under the contract including any methods adopted for performance of their tasks / work.
4. That Contractor shall ensure ,at its own expense to arrange for and procure, implement all requisite accident prevention tools, first aid boxes, personal protective equipment, fire extinguisher, safety training, Material Safety Data Sheet, pre-employment medical test, etc. for operations & activities including as & when so specified by TPCODL specifically. , failing which TPCODL shall be entitled, but not obliged, to provide the same and recover the actual cost thereof from the Contractor's payments.
5. That the Contractor shall engage adequate and competent Safety – Supervisor / Engineer / Manager / Skilled persons at site as per the Para 5 (Qualification and experience of safety personnel) and Annexure 3 of Contract Safety Management.
6. That the Contractor shall engage the competent Site – Supervisor with each group of workers for safe and correct workmanship, proper co-ordination of material and site work as per contract.

Doc. Title	GENERAL CONDITIONS OF CONTRACT - COMPOSITE WORKS	
Rev. No	0	Page 90 of 104

7. That the Contractor shall immediately replace supervisor in case it is found to be not up to the level of skill and experience required as in skill and experience required in *annexure 5* of this document, but any such replacement shall be only with the prior concurrence of TPCODL .
8. That the Contractor and its subcontractors shall abide by all the safety guidelines as per Safety Manual, Contract Safety Management and other guidelines issued from time to time by TPCODL during the contract period.
9. That in case the Contractor and/or any of its Subcontractor fail to ensure the compliance as required in terms of this undertaking the Contractor shall keep and hold TPCODL / its directors / officers / employees indemnified against any / all losses / damage / expense / liability / fines / compensation / claims / action / prosecutions or the like which might be suffered by TPCODL or to which TPCODL might get exposed to as a result of any breach /wilful negligence /deliberate default on the part of the Contractor /Subcontractor in complying with the same. Contractor shall also furnish any press release, clarification etc. if sought by TPCODL for any near miss or safety violations, accidents, which are attributable to fault of Contractor.

DEPONENT

VERIFICATION

Verified at Bhubaneswar on this \_Day of \_\_\_\_\_20\_\_ that the contents of the above affidavit are true and correct and nothing material has been concealed therefrom

DEPONENT

Doc. Title	GENERAL CONDITIONS OF CONTRACT - COMPOSITE WORKS	
Rev. No	0	Page 91 of 104

**Annexure 5 (Refer Para 5.4)**

**SKILL / QUALIFICATION REQUIRED FOR ELECTRICIAN AND ELECTRICAL SUPERVISOR**

**Skill / Qualifications Required for Electrician (*Certificate of Competency Class-II*):**

1. Formal education in ITI – Wireman/ Electrician trade.

OR

2. Working experience of minimum three years of practical wiring.

OR

3. Have completed three years apprenticeship course through Apprenticeship Advisor, Govt. of Odisha / other state Govt. in the trade of Lineman / Wireman / Electrician.
4. A candidate must have attained the age of Eighteen years.

**Skill / Qualifications Required for Electrical Supervisor (*Certificate of Competency Class-I*):**

1. Have at least five years' experience of practical wiring after passing the certificate of competency class-II i.e. electrician.

OR

2. Recognized Degree or Diploma or equivalent qualification in Electrical Engineering from any Technical institute / College or University recognized by the Board.

AND

Must have completed the training/job in rectifying the common defects in electrical line and power installation for a period of one and three years after passing Degree or Diploma respectively

OR

3. Possessing the valid certificate of certificate of competency class – 1 (Electrical Supervisor)

Doc. Title	GENERAL CONDITIONS OF CONTRACT - COMPOSITE WORKS	
Rev. No	0	Page 92 of 104

## **Annexure 6 (Refer Para 5.6)**

### **Training Module for BAs Worker & Supervisor**

#### **Training for BA Supervisor**

**Duration – 02 Hrs / Month**

**Methodology:** Lecture and Practical Demonstration of Safety Zone Creation

#### **Session: 1**

**Topic:** Electrical Safety Aspects

#### **Sub Topics:**

1. Learning specifics of HT & LT Network of zone
2. Major type of HT / LT / service lines / street light maintenance works
3. Understanding the need of Safety
4. Understanding the safe process of maintenance :
  - Planning of the maintenance job
  - Availability of men, material & machine, PPEs, Safety gear and approved PTW
  - Briefing of the job by the supervisor of the TPCODL
  - Identification of Risks associated with the maintenance work and planning for controlling measures by TPCODL supervisor
  - Creation of safety zone by TPCODL supervisor and satisfying that the network is dead – Use of Neon Tester, Shorting Chain and Safety Tagging
  - Start of the work – Right person for the right job
  - Alert supervision
  - Completion of the job – Check points
  - Energization of network
  - Actions to be taken in case of some accident

#### **Session: 2**

**Topic:** Use of Electrical Testing Equipment

**Methodology:** Lecture and Practical Demonstration

#### **Sub Topics:**

1. Meggar, Hi Pot, Clamp On Meter, Neon Tester, Discharge Rod, Line tester etc.

#### **Session: 3**

**Topic:** Awareness of Electrical Safety Aspects

- A. Understanding the need of this Training and Safety
- B. Learning specifics of HT & LT Network
- C. Major type of work to be carried out in zones
- D. Switching Operations (Do's & Don'ts) including Street Light Switching
- E. Working on Height (*practical demo also*)
- F. Understanding the Safe Process of Maintenance / Working:
  - Planning of the job
  - Availability of men, material & machine, PPEs, Safety gear and approved PTW
  - Briefing of the job by the supervisor
  - Permit to Work
  - Safety Tagging and Lock Out Tag out

Doc. Title	GENERAL CONDITIONS OF CONTRACT - COMPOSITE WORKS	
Rev. No	0	Page 93 of 104

- Identification of Risks associated with the work to be carried out and planning for controlling measures by proper supervision
- Concept of “**Safety Zone**”
- Identification and use of Neon Tester, Shorting Chain, Clamp On Meter, Hi Pot, Meggar etc.
- Completion of the job – Check points
- Accident Theory & Incident Reporting
- Actions to be taken in case of some accident

**Session: 4**

**Topic: Identification, Demonstration and Usages of Tools, PPEs and other Safety Gears and demonstration of working on HT pole**

**Session: 5**

**Topic: Practical demonstration of Safety Zone creation**

**FREQUENCY**

**Regular Safety Training Program**

- It will be conducted for all field & supervisor staff of BA in such a manner that all BA Personnel attend at least two hours safety training during every month.

**One Day Induction Safety Training Programs:**

- This training will be for the new BA’s personnel, who have been cleared by the Cross Functional Panel to undergo Safety training and who are likely to be deployed at various work sites of TPCODL by the BA, as a part of AMC / Work Contract.

**Duration / Periodicity:**

- Duration and periodicity has been defined above. However, this is subject to change at the discretion of TPCODL.

**Annexure 7 (Refer Para 5.7)**



**LIST OF PERSONAL PROTECTIVE EQUIPMENT AND TESTING FREQUENCY**

Sl. No.	Name of PPE	IS / EN Standard	Testing Frequency	Remarks	Ref Brand & Model
01	Leather Safety Shoes (Color – Black) with PU toe cap.	IS:15298 (Part-2)	Monthly and visual check every day for any crack or damage in the leather or sole.		BATA (Model No.- Endura L/C)  Liberty (Model No. – 7198-01 HT Barton Black – Warrior)
02	HDPE Safety helmet with chin strap and ratchet type for adjustment.	IS:2925-1984	Monthly and visual check every day for any crack in shell.		Karam (PN Safetech )  Joseph Leslie  Accent Industries  Honeywell
03	Full body harness (Safety belt)	EN 361	Monthly and visual check every day of the bends and the harness.		Karam (PN Safetech )  Joseph Leslie  Accent Industries
04	Electrical Safety Gloves	EN: 60903 CE marked	Weekly and visual check for any crack and blow test before every work.	Manufactured not beyond 12 months.	Make Sparian / Sumitech / CATU supplied with inner cotton glove with over glove of split leather.
05	Full face visor with safety helmet	EN: 166 CE marked (Visor)	Monthly and visual check every day for any crack in shell.	Clear acrylic visor attached with safety helmet.	Karam (PN Safetech )  Joseph Leslie  Accent Industries  Honeywell
06	Fire Proof jacket for chest protection		Monthly and visual check every day.		
07	Safety Chain for shorting cum earthing.	As per TPCODL standard	Weekly and visual check before every work.	Made of brass, Total length – 5.5 meters and made of 12 SWG.	

Note:

1. Any other Personal Protection Equipment required beyond above list will be according to BIS or EN Standards.
2. All Personal Protection Equipment will be checked by the engineer in-charge or SAFETY group of TPCODL.
3. Safety Representative of the BA has to maintain the record of the availability, condition and checking of the PPEs.
4. All tools required as per the contract must be according to respective IS / EN standards.
5. TPCODL may revise or add the above list of PPE and their specifications as and when feel necessary. The information about new specifications /models will be circulated by the Engineer In-charge (EIC), which shall adhere by the business associated in the shortest possible time. The EIC shall issue a memo / instruction to BA with timeline for implementation. Any delay will be treated as non- compliance / safety violations. Refer picture of each PPE given in next page.

**Pictures of PPE for reference purpose.**

Sl. No.	Name of PPE	IS / EN Standard	Picture
01	Leather Safety Shoes (Color – Black) with PU toe cap.	IS:15298(Part-2) and with test report of electrical resistance.	
02	HDPE Safety helmet with chin strap and ratchet type for adjustment.	IS:2925-1984	
03	Full body harness (Safety belt)  The straps at shoulder and thigh shall have full pad for comfort. The back shall be so designed that harness straps do not tangle with each other.	EN 361:2002 EN 358 : 2000 IS: 3521:1991/2002	

04	Electrical Safety Gloves – Composite type Soft electrical gloves as per size of individual.	EN: 60903 CE marked	
05	Full face visor with safety helmet	EN: 166 CE marked (Visor)	
06	Fire Proof jacket for chest protection		
07	Safety Chain for shorting cum earthing.	As per TPCODL standard	
08	Reflective jacket to each workmen	As per TPCODL standard	

*Note : Picture shown are for indicative purpose only. Actual product may differ.*



**Annexure 8 (Refer Para 5.8) LIST OF AUDITS TO BE CONDUCTED**

Audits	Responsibility	Freq.	Ref. Doc.
Permit to Work & Field Audit	BA Safety Representative	Weekly	F04 (COR P - 12)
Tool Bag & PPE's Audit		Weekly	F06 (COR P - 12)
First Aid Box Maintenance Record		Fortnightly	F08 (COR P - 12)
Fire Extinguisher Record <i>(Applicable for the BA involved in major construction works and have storage of flammable material at worksite)</i>		Monthly	F09 (COR P - 12)
Safety Talk Register		Weekly	F18 (COR P - 12)
Site Safety Audit		Daily	F29A (COR P - 12)

Note:

1. (BA Safety Representative has to use the formats as per Safety process COR – P – 12 of TPCODL)

**Annexure 9 (Refer Para 5.9)**

**PERFORMANCE REPORT – SAFETY**

**FOR THE MONTH OF.....**

Name of BA : .....

Name of the Project and Purchase order No: .....

Date of commencement of work: .....

Man Hour Worked in this month (No. of employees X 8 Hrs + Overtime): .....

Cumulative Man Hour worked: .....

Total Number of Minor Injury (this month): ..... Minor Injury (Total) .....

Major Injury (this month): ..... Major Injury (Total): .....

Detail of the Incident / Sub Standard Acts and Condition

Activity	This Month	Cumulative (Total)	Day Lost (this month)	Days Lost (Cumulative)
No. of the Incident				
No. of lost time injuries				
No. of dangerous occurrences				
No. of near miss reported				
Substandard Act/Conditions observed			Attach details of observation of this month	
Safety Violation Notice received (from TPCODL) (both in numbers and in Rs.)	No.	No.	No. of violation letter received and compliance report for the TPCODL.	
	Rs.	Rs.		

*Note: Cumulative means total from date of commencement of work according to the contract.*

Detail of the Accident / Near Miss Incidents:

Date and Time	Type of the incident	Name of Employee	Brief Description	Corrective and Preventive actions recommended

Details of the Safety Violations:

Doc. Title	GENERAL CONDITIONS OF CONTRACT - COMPOSITE WORKS	
Rev. No	0	Page 99 of 104

Date and Location	Brief Description	Name of employee involved	Action Taken

Detail of the Safety Talk / Tool Box Talk / Safety Training

Date and Location	Topic (s)	Total Number of employees (Worker / Supervisor)	Number of participants (Worker / Supervisor)

Detail of the Safety Meeting

Date and Location	Number of participants	Topics discussed	Major Observations / Innovation

Detail of the Safety Inspection /Audit: (as per TPCODL site audit checklist F29A(COR-P-12)

Date	Area / Location	Major Observations	Recommendations	Action Taken

Any other Safety, Occupational Health, Environment & Disaster Management Promotional Activity (During this month):

Date	Location	Activity	Level of Participation	Number of participation

Signature of the BA Safety Representative  
HoG

Signature of ZM /

Name, E. No. and Date

Name, E. No. Date.

*Note: The original form to be deposited with Engineer in-charge and a copy to SAFETY group on or before 5<sup>th</sup> of every month along with bill. List of training of the current month and status of PPE to be also mentioned individual wise.*

*BA may include additional lines if required. The TPCODL may revise the format as and when deemed required.*

Doc. Title	GENERAL CONDITIONS OF CONTRACT - COMPOSITE WORKS	
Rev. No	0	Page 100 of 104

**ANNEXURE-M**  
**VENDOR APPRAISAL FORM**

<b>TO BE SUBMITTED BY VENDOR (To be filled as applicable)</b>		
<b>VENDOR:</b>		
<b>1.0</b>	<b>DETAILS OF THE FIRM</b>	
	1.1	NAME (IN CAPITAL LETTERS) :
	1.2	TYPE OF CONCERN (PROPRIETARY) Partnership, Pvt. Ltd., Public Ltd. etc. :
	1.3	YEAR OF ESTABLISHMENT :
	1.4	LOCATION OF OFFICE POSTAL ADDRESS TELEGRAPHIC ADDRESSES, TELEX NO. FAX NO. :
	1.5	LOCATION OF MANUFACTURING UNITS :
		i) UNITS 1 :
		ii) OTHER UNITS :
<b>2.0</b>	<b>PRODUCTS MANUFACTURED</b> :	
<b>3.0</b>	<b>TURNOVER DURING THE LAST 3 YEARS (TO BE VERIFIED WITH THE LATEST PROFIT &amp; LOSS STATEMENT).</b> :	
<b>4.0</b>	<b>VALUE OF FIXED ASSETS</b> :	
<b>5.0</b>	<b>NAME &amp; ADDRESS OF THE BANKERS</b> :	
<b>6.0</b>	<b>BANK GUARANTEE LIMIT</b> :	
<b>7.0</b>	<b>CREDIT LIMIT</b> :	
<b>8.0</b>	<b>TECHNICAL</b>	
	8.1	NO.OF DESIGN ENGINEERS (INDICATE NO.OF YEARS EXPERIENCE IN RELATED FIELDS) :
	8.2	NO.OF DRAUGHTSMEN :
	8.3	COLLABORATION DETAILS (IF ANY) :
		8.3.1 DATE OF COLLABORATION :
		8.3.2 NAME OF COLLABORATOR :

Doc. Title	GENERAL CONDITIONS OF CONTRACT - COMPOSITE WORKS	
Rev. No	0	Page 101 of 104

		8.3.3 RBI APPROVAL DETAILS	:
		8.3.4 EXPERIENCE LIST OF COLLABORATOR	:
		8.3.5 DURATION OF AGREEMENT	:
	8.4	AVAILABILITY OF STANDARDS / DESIGN PROCEDURES / COLLABORATOR'S / DOCUMENTS (CHECK WHETHER THESE ARE LATEST/CURRENT	:
	8.5	TECHNICAL SUPPORT, BACK-UP GUARANTEE, SUPERVISION, QUALITY CONTROL BY COLLABORATOR (WHEREVER ESSENTIAL). (THIS CLAUSE IS RELEVANT WHEN VENDOR'S EXPERIENCE IS INADEQUATE)	:
	8.6	QUALITY OF DRAWINGS	:
<b>9.0</b>	<b>MANUFACTURE</b>		
	9.1	SHOP SPACE, LAYOUT LIGHTING, VENTILATION, ETC.	:
	9.2	POWER (KVA)	:
		MAINS INSTALLED	:
		UTILISED	:
		STANDBY POWER SOURCE	:
	9.3	MANUFACTURING FACILITIES (ATTACH LIST OF EQUIPMENT AS APPLICABLE)	:
		9.3.1 MATERIAL HANDLING	:
		9.3.2 MACHINING	:
		9.3.3 FABRICATION	:
		9.3.4 HEAT TREATMENT	:
		9.3.5 BALANCING FACILITY	:
		9.3.6 SURFACE TREATMENT PRIOR TO PAINTING/ COATING, POLISHING, PICKLING, PASSIVATION, PAINTING, ETC.	:
	9.4	SUPERVISORY STAFF	:
	9.5	ADEQUACY OF SKILLED LABOURS (MACHINISTS, WELDERS, ETC.)	:
	9.6	NO. OF SHIFTS	:
	9.7	TYPE OF MATERIAL HANDLED (SUCH AS CS, SS, ETC.)	:

	9.8	WORKMANSHIP	:
	9.9	MATERIAL IN STOCK AND VALUE	:
	9.10	TRANSPORT FACILITIES	:
	9.11	CARE IN HANDLING	:
<b>10.0</b>	<b>INSPECTION / QC / QA / TESTING</b>		
	10.1	NUMBER OF PERSONNEL (INDICATE NO.OF YEARS OF EXPERIENCE)	:
	10.2	INDEPENDENCE FROM PRODUCTION	:
	10.3	AVAILABILITY OF PROCEDURAL WRITE UP/QUALITY PLAN	:
	10.4	INCOMING MATERIAL CONTROL AND DOCUMENTATION	:
	10.5	RELIABILITY/REPUTATION OF SUPPLY SOURCES	:
	10.6	STAGE INSPECTION AND DOCUMENTATION	:
	10.7	SUB-ASSEMBLY & DOCUMENTATION	:
	10.8	FINAL INSPECTION AND DOCUMENTATION	:
	10.9	PREPARATION OF FINAL DOCUMENTATION PACKAGE	:
	10.10	TYPE TEST FACILITIES	:
	10.11	ACCEPTANCE TEST FACILITIES	:
	10.12	CALIBRATION OF INSTRUMENTS AND GAUGES (WITH TRACEABILITY TO NATIONAL STANDARDS) (ATTACH LIST)	:
	10.13	STATUTORY APPROVALS LIKE BIS, IBR, ETC.(AS APPLICABLE)	:
	10.14	SUB-VENDOR APPROVAL SYSTEM AND QUALITY CONTROL	:
	10.15	DETAILS OF TESTS CARRIED OUT AT INDEPENDENT RECOGNISED LABORATORIES	:
		i) FURNISH LIST OF TESTS CARRIED OUT AND THE NAME OF THE LABORATORY WHERE THE TESTS WERE CONDUCTED	:
		ii) CHECK AVAILABILITY OF CERTIFICATES AND REVIEW THESE WHEREVER POSSIBLE	:
<b>11.0</b>	<b>EXPERIENCE (INCLUDING CONSTRUCTION / ERECTION / COMMISSIONING) TO BE FURNISHED IN THE FORMAT INDICATED IN APPENDIX)</b>		
<b>12.0</b>	<b>SALES, SERVICE AND SITE ORANISATIONAL DETAILS</b>		

Doc. Title	GENERAL CONDITIONS OF CONTRACT - COMPOSITE WORKS	
Rev. No	0	Page 103 of 104

13.0	<b>CERTIFICATE FROM CUSTOMERS (ATTACH COPIES OF DOCUMENTS)</b>	:
14.0	<b>POWER SITUATION</b>	:
15.0	<b>LABOUR SITUATION</b>	:
16.0 *	<b>APPLICABILITY OF SC/ST RELAXATION (Y/N) IF YES, SUPPORTING DOCUMENTS TO BE ATTACHED</b>	
17.0	<b>ORGANIZATIONAL DETAILS</b> 1. PF NO 2. ESI NO 3. INSURANCE FOR WORK MAN COMPENSATION ACT NO 4. ELECTRICAL CONTRACT LIC NO 5. ITCC / PAN NO 6. SALES TAX NO 7. WC TAX REG. NO	:
18.0	<b>DOCUMENTS TO BE ENCLOSED:</b> 1. FACTORY LICENSE 2. ANNUAL REPORT FOR LAST THREE YEARS 3. TYPE TEST REPORT FOR THE ITEM 4. PAST EXPERIENCE REPORTS 5. ISO CERTIFICATE –QMS, EMS, OHAS, SA 6. REGISTRATION OF SALES TAX 7. COPY OF TIN NO. 8. COPY OF SERVICE TAX NO. 9. REGISTRATION OF CENTRAL EXCISE 10. COPY OF INCOME TAX CLEARANCE. 11. COPY OF PF REGISTRATION 12. COPY OF ESI REGISTRATION 13. COPY OF INSURANCE FOR WORK MAN COMPENSATION ACT NO 14. COPY OF ELECTRICAL CONTRACT LIC NO 15. COPY OF PAN NO 16. COPY OF WC TAX REGISTRATION 17. DOCUMENTS IN SUPPORT OF SC/ST RELAXATION AT S.NO.16.0 18. GST Registration No	

\* Classification of BA s under SC/ST shall be governed under following guidelines:

- **Proprietorship/ Single Ownership Firm:** Proprietor of the firm should be from SC/ST community. Governing document shall be Proprietorship Deed.
- **Partnership Firm:** Only such firms shall qualify which have SC/ST partners holding equal to or more than 50% of the total ownership pattern of the firm. Governing document shall be Partnership Deed.
- **Private Limited Company:** Only such firms shall qualify which have SC/ST directors holding equal to or more than 50% of the total ownership pattern of the firm. Governing document shall be Memorandum of Understanding (MoU) and/or Article of Association (AoA).

**NOTE: Certification from SC/ST Commission shall be required for deciding upon SC/ST status of a person.**

Doc. Title	GENERAL CONDITIONS OF CONTRACT - COMPOSITE WORKS	
Rev. No	0	Page 104 of 104

**ANNEXURE-N**

**MANUFACTURER AUTHORIZATION FORM**

*(To be submitted on OEM's Letter Head)*

Date: .....

Tender Enquiry No.: .....

To,  
 Chief (Procurement & Stores)  
 TP Central Odisha Company Limited,  
 Bhubaneswar

Sir,

WHEREAS M/s. [name of OEM], who are official manufacturers of ..... having factories at [address of OEM] do hereby authorize M/s [name of bidder] to submit a Bid in relation to the Invitation for Bids indicated above, the purpose of which is to provide the following Goods, manufactured by us

.....

and to subsequently negotiate and sign the Contract.

We hereby extend our full guarantee and warranty in accordance with the Special Conditions of Contract or as mentioned elsewhere in the Tender Document, with respect to the Goods offered by the above firm in reply to this Invitation for Bids.

We hereby confirm that in case, the channel partner fails to provide the necessary services as per the Tender Document referred above, M/s [name of OEM] shall provide standard warranty on the materials supplied against the contract. The warranty period and inclusion / exclusion of parts in the warranty shall remain same as defined in the contract issued to their channel partner against this tender enquiry.

Yours Sincerely,

For .....

Authorized Signatory

