



Date: 25-07-2023

Tender Ref: TPCODL/P&S/1000000394/2023-24

**Sub: Corrigendum to open tender number TPCODL/P&S/1000000394/23-24,
Rate Contract for Supply of HG Fuse .**

(A) With reference to above NIT concerned bidders may note following modification to Annexure-II Technical Specification.

Encl. Modified Technical Specification Annexure- II

(B) Extension of Bid Submission due Date as follows.

Existing Bid Submission due date	Amended bid submission due date
25-07-2023 till 1500 hrs.	31-07-2023 till 1500 hrs.

(C) Pre-Bid query clarification (Enclosed)

All other terms and conditions of the above tender will remain same.

By Order
Chief-Procurement & Store, TPCODL

CONTENTS

1. SCOPE
2. APPLICABLE STANDARDS
3. CLIMATIC CONDITIONS OF THE INSTALLATION
4. GENERAL TECHNICAL REQUIREMENTS
5. GENERAL CONSTRUCTIONS
6. MARKING
7. TESTS
8. TYPE TEST CERTIFICATES
9. PRE-DISPATCH INSPECTION
10. INSPECTION AFTER RECEIPT AT STORES
11. GUARANTEE
12. PACKING
13. TENDER SAMPLE
14. QUALITY CONTROL
15. TESTING FACILITIES
16. MANUFACTURING FACILITIES
17. SPARES, ACCESSORIES AND TOOLS
18. DRAWINGS AND DOCUMENTS
19. DRAWING FOR TENDER REFERENCE
20. SCHEDULE "A" GUARANTEED TECHNICAL PARTICULARS
21. SCHEDULE "B" DEVIATIONS

1. SCOPE:

This specification covers the design, manufacture, testing and supply of 11 KV, 200 A, 3 pole HG Fuse sets for outdoor installations to be used for 33/11 KV Substations. Scope also includes transportation & unloading of poles at store /site.

2. APPLICABLE STANDARDS:

The equipment covered by this specification shall unless otherwise stated, be designed, manufactured and tested in accordance with the latest editions of the following Indian, International Standards and shall conform to the regulations of the local authorities:

IS 9385	High voltage fuses
IS 2062	Hot Rolled Medium and High Tensile Structural Steel
IS 209	Zinc Ingot
IS 2629	Recommended Practice for Hot-Dip Galvanizing of Iron and Steel
IS 2633	Methods for testing uniformity of coating of zinc coated articles
IS 4759	Hot-dip zinc coatings on structural steel and other allied products
IEC 62231	Composite station post insulators for substations with AC voltages greater than 1000 V up to 245 kV – Definitions, test methods and acceptance criteria.
IEC 60273	Characteristic of Indoor and Outdoor Post Insulators for Systems with Nominal Voltages Greater than 1000 V

3. CLIMATIC CONDITIONS:

1	Maximum ambient temperature	50 deg C
2	Max. Daily average ambient temp	35 deg C
3	Min Ambient Temperature	0 deg C
4	Maximum Humidity	95%
5	Average Annual Rainfall	1500 mm
6	Average No. of rainy days per annum	120
7	Altitude above MSL not exceeding	1000m
8	Wind Pressure	300 Km/hr
9	Earthquakes of an intensity in horizontal direction	equivalent to seismic acceleration of 0.3g
10	Earthquakes of an intensity in vertical direction	equivalent to seismic acceleration of 0.15g (g being acceleration due to gravity)

TPSODL/TPNODL/TPWODL/TPCODL service area has heavy saline conditions along the coast and High cyclonic Intensity winds with speed upto 300 Kmph. The atmosphere is generally laden with mild acid and dust in suspension during the dry months and is subjected to fog in cold months.

4. GENERAL TECHNICAL REQUIREMENTS:

SL. NO.	TECHNICAL PARTICULARS	DESIRED VALUE
1	Name of Manufacturer	To be Specified by Bidder
2	Works Address	To be Specified by Bidder
3	Manufacturers Type	To be Specified by Bidder
4	Standard according to which the HGF are manufactured	IS 9385-1980 (Part-II) amended upto date, IEC 62231/60273
5	Rated Voltage	12 kV
6	Rated Frequency	50 Hz
7	Lightning Impulse Withstand Voltage Positive & Negative Polarity (1.2/50 micro sec wave)	
a.	Across the Isolating distance	85 kV (Peak)
b.	To Earth & Between Poles	75 kV (Peak)
8	Dry Flashover Voltage	85 kV
9	Power frequency Puncture withstand Voltage	1.3 times of actual dry flashover voltage
10	Impulse Withstand Voltage (Switch in position)	75 kV (Peak)
11	Visible Discharge Voltage	9kV RMS
12	1 Min. Power Frequency Withstand Voltage (Dry & Wet)	
a.	Across the Isolating distance	32 kV
b.	To Earth & Between Poles	28 kV
13	Temperature Rise	Within permissible limit as per IS 9385-1980 (Part-II) amended upto date
14	Outdoor/Indoor	Outdoor
15	Type of mounting	Horizontal
16	Vertical clearance from top of insulator cap to mounting Channel	254mm (Minimum)
17	Continuous current Rating	200 Amp
18	Aluminium Strip for HG Fuse	N/A
19	11kV Polymer Post Insulator	
a.	Applicable Standard	IEC 62231 amended up to date
b.	Make of Post Insulator	To be Specified by Bidder
c.	Minimum failing load	5 kN
d.	CD of Post Insulator (min.)	320 mm
e.	Number of Insulators per Pole	2 Nos.
f.	Diameter of FRP Rod (min.)	24 mm
20	Total weight of Horn Gap Fuse	To be Specified by Bidder

21	Details of Arcing Horn	1 SWG (7.62 mm) dia. Solid copper rod silver plated provided with screwing arrangement on the fuse carrier made of copper for fixing fuse wire (Total length -635 mm). All the bolts, Nuts and washers should be made out of Brass
22	Riser Unit (150 mm height total)	The shape of connectors may be made out of straight copper Casting. Copper Riser 40 mm width x 5 mm Thick x 50mm height Copper Connector 40 mm width x 5 mm thick x 40 mm length. All Nonferrous parts shall be silver plated with coating thickness of (25 microns min.)
		b) 100 mm height G.I Riser made of 19 mm nominal bore medium gauge G.I pipe welded with 2 nos. of G.I flat of 30mmx5mm of both ends fixed with 10mm dia. bolts and nuts with flat & spring washer. All the bolts, Nuts and washers should be made out of Brass
23	Size of Base Channel	75mmx40mmx4.8mm Length Min. 500 mm (mounting slotted hole 18x 36 mm c/c 250 mm) a) All ferrous parts shall be hot dipped Galvanized as per IS.2633/1972 (Latest Amendment), IS 2629/1985 (1st. Revision), & all nonferrous parts should be duly electroplated with silver.
24	Connectors	SOCKET: Two no. of bimetallic copper sockets shall be used at both ends suitable for 55-100 sq. mm AAAC conductor.
25	Marking/Engraving	TPSODL/TPNODL/TPWODL/TPCODL, Serial No., Manufacture's name or trademark, Month & Year of Manufacturing.

5. GENERAL CONSTRUCTION:

The H.G. Fuses shall have adjustable arcing horns made of solid copper rod having 7.62 mm dia. The horns shall be fitted with screwing devices with fly nuts for fixing and tightening the fuse wire. It shall have robust terminal connector of size as per clause no.4 made of copper duly silver plated with two numbers of 12mm dia. brass bolts and double nuts with flat brass washers. The connector should be capable of connecting crimp able conductor up to 100 Sq.mm. size (AAAC) with bimetallic solder less sockets. The H.G. Fuse Set shall be suitable for horizontal mounting on Sub-station structures. All metal (ferrous) parts shall be galvanized and polished.

5.1 Insulators:

The post type insulators used for the Horn Gap Fuse Unit shall conform to IEC: 62231 (amended upto date) in all respects with regard to mechanical and electrical requirements.

The electrical characteristics of the insulators shall be as follows

1	System Voltage	11 kV
2	Lightning Impulse Withstand Voltage in kV	75
3	Power Frequency Withstand Voltage in kV (Dry)	55
4	Power Frequency Withstand Voltage in kV (Wet)	35
5	Power Frequency Flashover Voltage in kV (Dry)	85
6	Power Frequency Flashover Voltage in kV (Wet)	50
7	Creepage Distance in mm (min)	320
8	FRP Rod Dia. in mm (min)	24

Minimum failing loads for post Insulators should be 5kN for 11kV.

The type of insulation materials, metal fittings, Creepage distance, protected Creepage distance, tensile strength compression strength, torsion strength and cantilever strength shall be as provided in the guaranteed technical particulars in clause no.19.

The bidder shall furnish the type test certificate of the post insulators from their manufacturer for reference & scrutiny. For type, test reports refer cl no 7.3. Any fittings accessories or equipment which may not have been specifically mentioned in this specification but which are usually necessary in equipment shall be deemed included in the specification and shall be supplied by the Bidder without extra charge. All equipment shall be complete in all details whether such details are mentioned in the specification or not.

6. MARKING:

Below parameters should be embossed on SS sheet of thickness 1mm with black background. It should be riveted on MS channel of HG Fuse:

1. Rated Voltage
2. Manufacturer’s Name
3. Month/Year of Manufacture
4. Serial Number
5. PO no.
6. Rated normal current in Amps
7. Rated one second short-time current

7. TESTS:

The bidder shall be required to submit complete set of the following test reports along with the offer: -

7.1 ACCEPTANCE TESTS

- i) Power frequency voltage dry test.
- ii) Tests to prove satisfactory operation.
- iii) Dimension check.
- iv) Galvanization test.

7.2 ROUTINE TESTS

- i) Power frequency voltage dry test.
- ii) Tests to prove satisfactory operation.
- iii) Dimension check.
- iv) Galvanization test.

7.3 TYPE TESTS

- i) Impulse voltage dry test
- ii) Power frequency voltage dry test
- iii) Power frequency voltage wet test
- iv) Temperature rise test.
- v) Mechanical endurance test / Mechanical strength test for the post insulator.

Type tests on Post Insulators

- i) Dry Lightning impulse withstand voltage test.
- ii) Wet power frequency test
- iii). Damage limit proof test and test of tightness of the interface between end fittings & insulator housing
- iv). Radio interference test
- v). Recovery of hydrophobicity test
- vi). Chemical composition test for silicon content
- vii). Brittle fracture resistance test.

8. TYPE TEST CERTIFICATES:

The Bidder shall furnish the type test certificates for the tests as mentioned above as per the corresponding standards. All the tests shall be conducted at **CPRI/ERDA/ Other Govt. Lab** as per relevant IS. Type tests should have been conducted during the period not exceeding 05 years from the date of opening the bid. In the event of any discrepancy in the test reports, i.e. any test report not acceptable, same shall be carried out without any cost implication to TPSODL/TPNODL/TPWODL/TPCODL.

9. PRE-DISPATCH INSPECTION:

The material shall be subject to inspection by a duly authorized representative of the TPSODL/TPNODL/TPWODL/TPCODL. Inspection may be made at any stage of manufacture at the discretion of the purchaser and the equipment, if found unsatisfactory as to workmanship or material, the same is liable to rejection. Bidder shall grant free access to the places of manufacture to TPSODL/TPNODL/TPWODL/TPCODL's representatives at all times when the work is in progress. Inspection by the TPSODL/TPNODL/TPWODL/TPCODL or its authorized representatives shall not relieve the bidder of his obligation of furnishing equipment in accordance with the specifications. Material shall be dispatched after specific MDCC (Material Dispatch Clearance Certificate) is issued by TPSODL/TPNODL/TPWODL/TPCODL.

Following documents shall be sent along with material.

- a) Test reports
- b) MDCC issued by TPSODL/TPNODL/TPWODL/TPCODL
- c) TPSODL/TPNODL/TPWODL/TPCODL Invoice in duplicate
- d) Packing list
- e) Drawings & catalogue
- f) Guarantee / Warrantee card
- g) Delivery Challan
- h) Other Documents (as applicable)

10. INSPECTION AFTER RECEIPT AT STORE:

The material received at TPSODL/TPNODL/TPWODL/TPCODL store will be inspected for acceptance and shall be liable for rejection, if found different from the reports of the pre-dispatch inspection and one copy of the report shall be sent to Engineering department.

11. GUARANTEE:

Bidder shall stand guarantee towards design, materials, workmanship & quality of process/ manufacturing of items under the contract for due and intended performance of the same, as an integrated product delivered under this contract. In the event any defect is found by the Company up to a period of 12 months from the date of commissioning or 24 months from the date of last supplies made under the contract, whichever is earlier, supplier shall be liable to undertake to replace/rectify such defects at his own costs. within mutually agreed timeframe, and to the entire satisfaction of the Company, failing which the Company will be at liberty to get it replaced/rectified at supplier's risks and costs and recover all such expenses plus the Company's own charges (@ 20% of expenses incurred), from the supplier or from the "Security cum Performance Deposit" as the case may be.

12. PACKING AND TRANSPORT:

Supplier shall ensure that all material covered by this specification shall be prepared for rail/road transport (local equipment) and be packed in such a manner as to protect it from damage in transit. The bidder shall provide instructions regarding handling and storage precautions to be taken at site.

13. TENDER SAMPLE:

Not Applicable

14. QUALITY CONTROL:

The bidder shall submit QAP indicating the various stages of inspection, the tests and checks which will be carried out on the material of construction, components during manufacture and bought out items and fully assembled component and equipment after finishing. As part of the plan, a schedule for stage and final inspection within the parameters of the delivery schedule shall be furnished. The Purchaser's engineer or its nominated representative shall have free access to the manufacturer's/sub-supplier's works to carry out inspections.

15. TESTING FACILITIES:

Supplier/ Manufacturer shall have adequate in-house testing facilities for carrying out all routine tests & acceptance tests as per relevant Indian standards.

16. MANUFACTURING FACILITIES:

The successful bidder shall submit the bar chart for various manufacturing activities clearly elaborating each stage, with quantity. This bar chart should be in line with the Quality assurance plan submitted with the offer.

17. SPARES, ACCESSORIES AND TOOLS

Not applicable.

18. DRAWINGS AND DOCUMENTS:

Following drawings and documents shall be submitted in line with the requirement of Tender specifications:

- a) Completely filled in Schedule "A" Guaranteed Technical Particulars.
- b) Work Experience details
- c) Type test certificates.
- d) Drawing (3 sets) of HG fuse containing complete information about manufacturing & fabrication etc.

19. Drawing (reference for tender purpose only)

DRAWING REFERENCES IS FOR TENDERING PURPOSES ONLY. FINALIZATION OF GTP WILL BE AT THE TIME OF DETAILED ENGINEERING

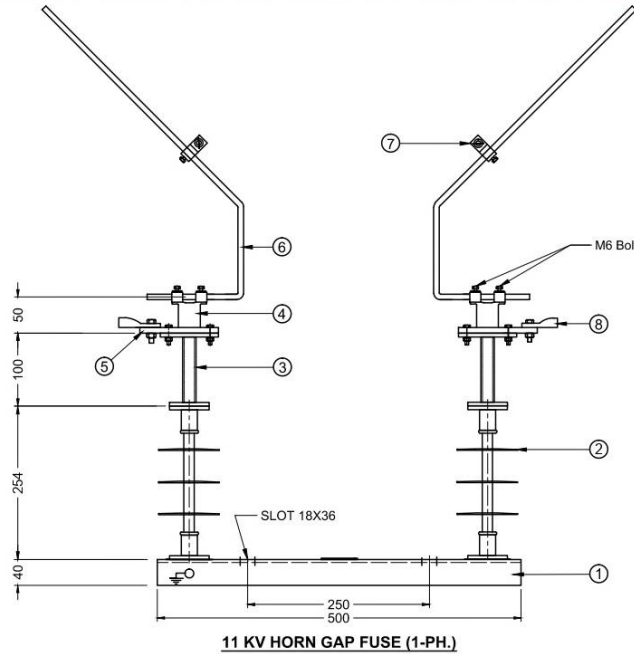

11 KV HORN GAP FUSE (1-PH.)

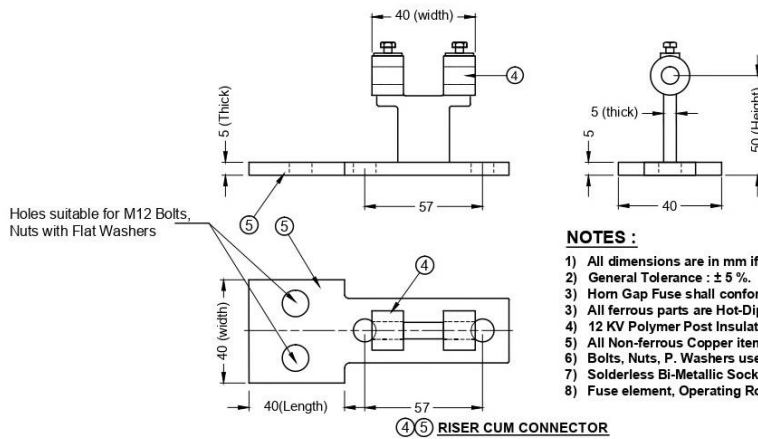

④⑤ RISER CUM CONNECTOR

NOTES :

- 1) All dimensions are in mm if not specified otherwise.
- 2) General Tolerance : ± 5 %.
- 3) Horn Gap Fuse shall conform to IS: 9385-1980 (Part-II) amended upto date.
- 3) All ferrous parts are Hot-Dip-Galvanized as per IS: 2633/1972, IS: 2629/ 1985 latest amendment
- 4) 12 KV Polymer Post Insulator shall conform to IEC: 61109 amended upto date.
- 5) All Non-ferrous Copper items are duly electroplated with silver of coating thickness 25 microns.
- 6) Bolts, Nuts, P. Washers used for assly. shall be M.S Galvanized. Sp. washers are M.S E.G.
- 7) Solderless Bi-Metallic Sockets shall be suitable for 80-100 sq. mm AAAC Conductor.
- 8) Fuse element, Operating Rod are not in scope of Supply of Ruma.

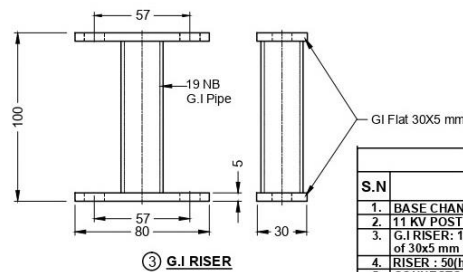

③ G.I RISER

BILL OF MATERIALS

S.N	DESCRIPTION	QTY. (3-Ph)	MATERIAL
1.	BASE CHANNEL : 75X40X5 X 500 LONG	3 no.	MILD STEEL HDG.
2.	11 KV POST INSULATOR (24 FRP); 57 PCD, 320 C.D	6 no.	POLYMER
3.	G.I RISER: 19NB G.I Pipe welded with Znos. G.I Flat of 30x5 mm at both ends (Total Height 100 mm)	6 no.	MILD STEEL HDG.
4.	RISER : 50(height) x 40(width) x 5(thick)	6 no.	COPPER ALLOY/BRASS SILVER
5.	CONNECTOR : 40(width) x 40(length) x 5(thick)	6 no.	COPPER ALLOY/BRASS SILVER
6.	HORN: '1' SWG (7.62 mm) Ø X 6.35 mm (total length)	6 no.	COPPER ROD SILVER
7.	FUSE ELEMENT HOLDER	6 no.	COPPER ALLOY/BRASS SILVER
8.	SOLDERLESS SOCKET (suitable for 80-100 sq. mm AAAC Conductor)	12 no.	AL. ALLOY (Bi-metallic)

20. SCHEDULE- "A" GUARANTEED TECHNICAL PARTICULARS:

SL. NO.	TECHNICAL PARTICULARS	Desired Value
1	Name of Manufacturer	
2	Works Address	
3	Manufacturers Type	
4	Standard according to which the HGF are manufactured	
5	Rated Voltage	
6	Rated Frequency	
7	Continuous current Rating	
8	Post Insulator	
8.1	Lightning Impulse Withstand Voltage Positive & Negative Polarity (1.2/50microsecwave)	
a	Across the Isolating distance	
b	To Earth & Between Poles	
8.2	1 Minute Power Frequency Withstand Voltage (Dry)	
8.3	1 Minute Power Frequency Withstand Voltage (Wet)	
8.4	Visible Discharge Voltage	
8.5	Dry Flashover Voltage	
8.6	Power frequency puncture withstand voltage	
8.7	Impulse Withstand Voltage (Switching Position)	
9	1 Minute Power Frequency Withstand Voltage	
a	Across the Isolating distance	
b	To Earth & Between Poles	
10	Temperature Rise	
11	Outdoor/Indoor	
12	Type of mounting	
13	Vertical clearance from top of insulator cap to mounting Channel	
13B	Height of the riser for carrying the horns.	
13C	Details of Arcing Horns	
13D	Riser Unit	
14	Connectors	
15	Size of Base Channel (HDG)	
16	Aluminium Strip for HG Fuse	
17	11 kV Post Insulator	
a.	Applicable Standard	
b.	Make of Post Insulator	
c.	Minimum failing load	
d.	CD of Post Insulator (min.)	
e.	Number of supporting Insulators per Pole	
18	Total weight of Horn Gap Fuse	
19	Marking/Engraving	



Specification No: ENG-HV-2021

Specification Name: Specification for 11kV 200A HG Fuse

21. SCHEDULE “B” DEVIATIONS:

(TO BE ENCLOSED WITH TECHNICAL BID)

All deviations from this specification shall be set out by the Bidders, clause by Clause in this schedule. Unless specifically mentioned in this Schedule, the tender shall be deemed to confirm the purchaser's specifications:

SL. No	Clause No.	Details of deviation with justifications

We confirm that there are no deviations apart from those detailed above.

Seal of the Company:

Signature

Designation

FORMAT F.1				
Format for Query / Clarification / Deviation (QCD)				
Tender No :	TPCODL/P&S/1000000394/23-24			
Package Name :	Rate Contract for Supply of 11kV & 33kV HG Fuse			
Note :				
Sr. No.	Detailed Reference to concerned Document . Please specify Document No / Clause No / Page No	Description as per Bid Document	Query / Clarification / Deviation	TPCODL Response
1	2	3	4	5
1	Page no.132 , SI no.18	Aluminium Strip for HG Fuse	Aluminium Strip for HG Fuse is NOT REQUIRED in HG Fuse supply.	Not req.
2	Page no.133, SI no.22	<p>Riser Unit (150 mm height total) -</p> <p>(i) The shape of connectors may be made out of straight copper Flat. (ii) Copper Riser 40 mm width x 5 mm Thick x 80mm height. Copper Connector 40 mm width x 5 mm thick x 40 mm length. (iii) All Nonferrous parts shall be silver plated with coating thickness of (25 microns min.)</p> <p>b) 100 mm height G.I Riser made of 19 mm nominal bore medium gauge G.I pipe welded with 2 nos. of G.I flat of 30mmx5mm of both ends fixed with 10mm dia. bolts and nuts with flat & spring washer. All the bolts, Nuts and washers should be made out of Brass.</p>	<p>Riser Unit (150 mm height total) -</p> <p>(i) The shape of connectors is made out of copper casting,as connector cannot be made of straight copper Flat. (ii) Kindly clear the difference between the Copper Riser & Copper Connector with its dimensions. (iii) Kindly allow the coating thickness of silver plating on non-ferrous parts from 25 micron to 10 micron as accepted in other tender before.</p> <p>(b) Kindly mention in which part the Brass the bolts, Nuts and washers is to provided as the GI Riser should be fitted with GI nut & bolt to provide strength.</p>	<p>i. Copper casting (for dimensions refer tender ref. drawing for ENG-HV-2021-R01)</p> <p>ii. Refer drawing for ENG-HV-2021-R01</p> <p>iii. 25 Microns</p> <p>b. tender ref. drawing- riser connector</p>
3	Page no.133, SI no.24	Connectors - SOCKET: Two no. of bimetallic copper sockets shall be used at both ends suitable for 55-100 sq. mm AAAC conductor	Kindly allow the Bimetallic Aluminium sockets as accepted in other tender before.	As per TS
5	Page no.133, Point no.5	GENERAL CONSTRUCTION: Two numbers of 12 mm dia. brass bolts and double nuts with flat brass washers.	Kindly mention in which part the two numbers of 12 mm dia. brass bolts and double nuts with flat brass washers is to be provided.	Tender ref. drawing- riser connector 4-hole 2nos. For incoming of 55-100sq.mm conductor 2nos. For riser to copper casting coupling