

## **OPEN TENDER NOTIFICATION**

### **FOR**

**One Year Rate Contract “Engineering, Supply, Installation, Testing & Commissioning of River Crossing work on Turnkey Basis Through PC+6, UR+6 & H Pole DP Structure” under Capex/Govt. Funded/Deposit work etc. TPCODL Jurisdiction**

**Tender No.: TPCODL/P&S/1000000541/23-24**

**Due Date for Bid Submission: 12<sup>th</sup> Feb 2024**

**TP Central Odisha Distribution Limited  
(A TATA Power and Odisha Government Joint Venture)  
Procurement & Stores Department,  
1<sup>st</sup> Floor, Anuj Building, Janpath Road, Bhubaneswar – 751022**

**TP CENTRAL ODISHA DISTRIBUTION LIMITED**  
 (A Tata Power & Odisha Govt. joint venture)

2nd Floor, IDCO Tower, Janpath Bhubaneshwar, Odisha 751022

**REAMBLE**

TP Central Odisha Distribution Limited (TPCODL) is a joint venture between Tata Power and the Government of Odisha with the majority stake being held by Tata Power Company (51%). TPCODL is a state electricity distribution utility with sole rights to distribution of electricity in the Central Zone in Odisha covering the distribution circles of Bhubaneswar, Cuttack, Paradeep and Dhenkanal in accordance with the Electricity Act. Tata Power Company has successfully won the bid to own the license for the distribution and retail supply of electricity in Odisha's five circles constituting Central Electricity Supply Utility of Odisha (CESU). It came into operation with effect from 01.06.2020. TPCODL serves a population of 1.36 Crore with Customer Base of 26 Lakh and a vast Distribution Area of 29, 354 Sq. Km. The primary business activity includes purchase of power from GRIDCO Ltd at BSP rate and distribute to consumers. The field structure has been presented below:

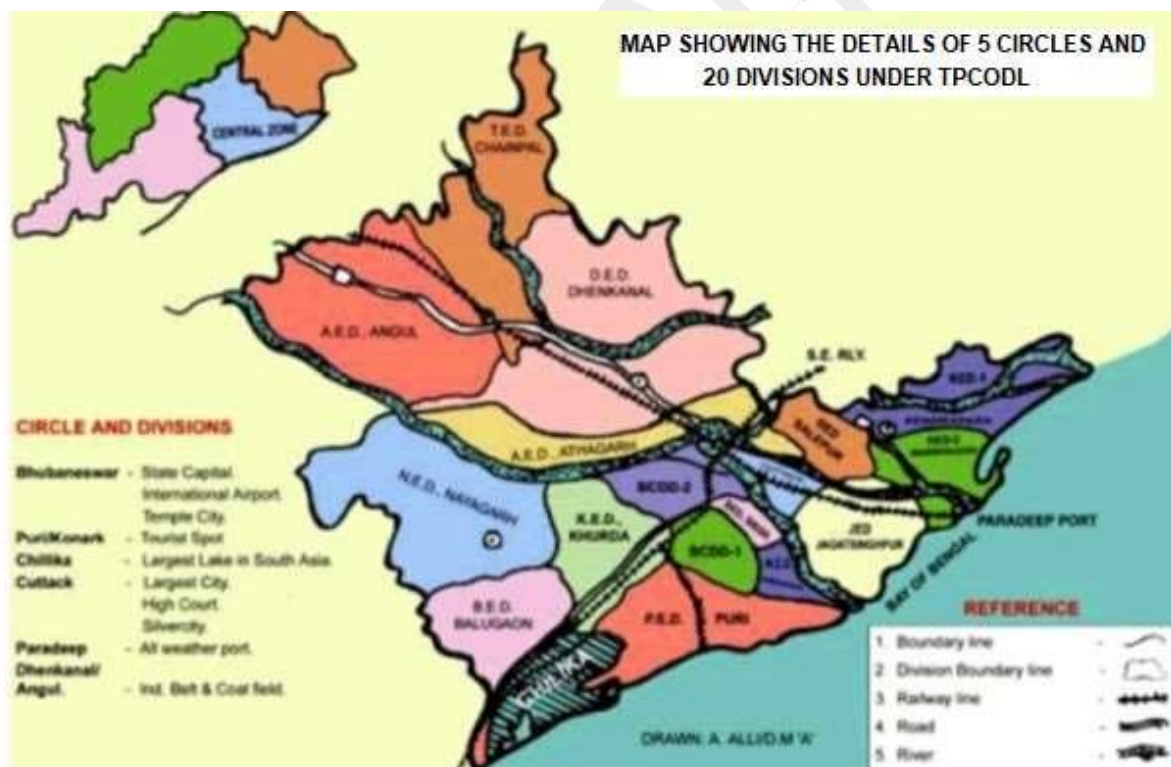

**TP CENTRAL ODISHA DISTRIBUTION LIMITED****(A Tata Power & Odisha Govt. joint venture)**

2nd Floor, IDCO Tower, Janpath Bhubaneshwar, Odisha 751022

**20 Electrical Divisions are as follows;**

1. Bhubaneswar City Distribution Division-I (BCDD-I)
2. Bhubaneswar City Distribution Division-II (BCDD-II)
3. Bhubaneswar Electrical Division (BED)
4. Nimapada Electrical Division, Nimapada (NED)
5. Khurda Electrical Division, Khurda (KED)
6. Balugaon Electrical Division, Balugaon(BEDB)
7. Nayagarh Electrical Division, Nayagarh (NYED)
8. Puri Electrical Division, Puri (PED)
9. City Distribution Division, Cuttack (CDD-I)
10. City Distribution Division, Cuttack (CDD-II)
11. Cuttack Electrical Division, Cuttack (CED)
12. Athagarh Electrical Division, Athagarh (AED)
13. Salipur Electrical Division, Salipur (SED)
14. Dhenkanal Electrical Division, Dhenkanal (DED)
15. Talcher Electrical Division, Chainpal (TED)
16. Angul Electrical Division, Angul (ANED)
17. Kendrapara Electrical Division, Kendrapara (KED-I)
18. Kendrapara Electrical Division, Marshaghai (KED-II)
19. Jagatsinghpur Electrical Division, Jagatsinghpur(JED)
20. Paradeep Electrical Division, Paradeep (PDP)

**TP CENTRAL ODISHA DISTRIBUTION LIMITED**

(A Tata Power &amp; Odisha Govt. joint venture)

2nd Floor, IDCO Tower, Janpath Bhubaneshwar, Odisha 751022

**INFORMATION TO THE BIDDERS TO PARTICIPATE IN E-TENDER SYSTEM OF TPCODL****-: Steps for E-tender submission:-**

**Bids are to be submitted only through online e-procurement platform, ARIBA. Any other form of bid submission will not be accepted. Online Link for submission of bid through ARIBA will be sent only after confirmation of payment of tender fee from bidder.**

**Step 1:**

The bidder can get primary information about the tender from the Newspaper advertisement / TPCODL website <[www.tpcentralodisha.com](http://www.tpcentralodisha.com)> and can download the tender document from the above website.

**Step 2:**

Non-Refundable Tender Participation Fee, as indicated in tender document, to be submitted before last date of tender fee payment, in the form of direct deposit/NEFT/RTGS in the following bank account.

Account Name: TP Central Odisha Distribution Limited

Bank Name: State Bank of India,

IDCO Towers, Bhubaneswar

Bank Account No. : 10835304915

IFSC Code : SBIN0007891

**Step 3:**

Eligible and Interested bidder to send an email to TPCODL attaching duly signed and stamped letter on Bidder's letterhead, with following details, expressing their intend to bid against above tender:

Sl No	Description	Bidder's Response
i)	Tender Enquiry No.	
ii)	Description of materials / Works Tendered	
iii)	<b>Package to be Participated for all scope</b>	
iv)	Name and address of the bidding company	
v)	Name of the authorized contact person	
vi)	Contact No. authorized person	
vii)	E-mail Id of the where online ARIBA link to be mailed.	
viii)	Tender Fee details (Amount / NEFT-RTGS UTR No / Date), Ref	
ix)	GST No. of bidder	

E-mail has to be sent to package owner Gaurav Singh <[Gaurav.singh@tpcentralodisha.com](mailto:Gaurav.singh@tpcentralodisha.com)> with copy to <[sudhakar.behera@tpcentralodisha.com](mailto:sudhakar.behera@tpcentralodisha.com)> before "Last date and time for payment of Tender Participation Fee".

**Step 4:**

On receipt of the document as mentioned in Step 3 above and after due verification of the same, ARIBA link for participation in the tender will be sent to bidder's mail address from ARIBA system.

**Step 5:**

In this mail there will be an online link as [Click Here](#) to participate in the tender.



**TP CENTRAL ODISHA DISTRIBUTION LIMITED**  
(A Tata Power & Odisha Govt. joint venture)

2nd Floor, IDCO Tower, Janpath Bhubaneshwar, Odisha 751022

**Step 6:** Click "[Click Here](#)" to access this event.

**Step 7:**

If bidder is bidding first time for TPCODL through ARIBA site then please "Sign UP" by creating User Name and password as mentioned in Sign Up page. Please follow the process, as mentioned in the Sign Up page, during creation of User Name and password. Also a simple one-page registration screen will open for first time user. All \* mark mandatory field to be filled in.

Those who are already having User Name and password for accessing TPCODL events, they can LOGIN using same User Name and password.

If bidder has got User name and password for their other customer, same will not be applicable for TPCODL.

**Step 8:** You will be able to see the RFQ

**Step 9:** After review and downloading of all documents click on "[Review Pre-requisites](#)"

**Step 10:** Review and accept "**Bidder Agreement**".

**Step 11:** You can see attached pdf tender document against clause no 1.1.1 (Introduction).

**Step 12:** Vendor has to attach pdf version of technical bid in clause no. 2.1 and 2.2. In this field do not attach any price document.

Price schedule is attached in clause no.3.2. Same has to be downloaded and price and tax details to be filled in as per the format given, print to be taken in vendor's letter head and signature and seal to be made by authorised person. PDF version of this price bid to be attached in clause 3.2 For Price Bid put all the unit price and taxes and duties in provided field. Put "0" (ZERO) in not applicable field.

Step 13: After successfully putting Techno commercial offer and price part then click on "[Submit Entire Response](#)"

**Note:** Once user ID and password created, bidder can also login to ARIBA site through the following [URL:https://service.ariba.com/Sourcing.aw/124997008/aw?awh=r&awssk=oxt0s1BN&dard=1](https://service.ariba.com/Sourcing.aw/124997008/aw?awh=r&awssk=oxt0s1BN&dard=1)

**TP CENTRAL ODISHA DISTRIBUTION LIMITED**

(A Tata Power &amp; Odisha Govt. joint venture)

2nd Floor, IDCO Tower, Janpath Bhubaneshwar, Odisha 751022

**CONTENTS OF THE ENQUIRY**

<b>S. NO.</b>	<b>PARTICULARS</b>
1.	Event Information
2.	Evaluation Criteria
3.	Submission of Bid Documents
4.	Bid Opening & Evaluation process
5.	Award Decision
6.	Order of Preference/Contradiction
7.	Post Award Contract Administration
8.	Specifications and Standards
9.	General Conditions of Contract
10.	Safety
<b>Annexures</b>	
I.	Annexure I – Schedule of Items (BOQ)
II.	Annexure II – Technical Specifications & Scope of Work
III.	Annexure III – Schedule of Deviations
IV.	Annexure IV – Schedule of Commercial Specifications
V.	Annexure V – Document Check List
VI.	Annexure VI – Acceptance Form for Participation in Reverse Auction Event
VII.	Annexure VII – General Condition of Contract
VII(a)	Annexure VIIa - Preferential Procurement norms for Local MSMEs
VIII.	Annexure VIII-Safety Terms and Conditions & Safety Policy
IX.	Annexure IX- Tata Code of Conduct (TCOC)
X.	Annexure X-Environment & Sustainability Policy
XI.	Annexure XI- Proforma for Bank Certificate for Bidder's Liquid Assets

**TP CENTRAL ODISHA DISTRIBUTION LIMITED**  
(A Tata Power & Odisha Govt. joint venture)

2nd Floor, IDCO Tower, Janpath Bhubaneshwar, Odisha 751022

## 1.0 Event Information

### 1.1 Scope of work

Open Tenders are invited through the e-tender bidding process from interested Bidders for entering into a *Contract* for Engineering, Supply , Testing & Commissioning of River Crossing all over TPCODL Area as defined below:

Tender Enquiry No	Name of Districts / Divisions	Work Description	EMD (Rs.) (incl. GST)*	Tender Participation Fee (Rs.) (Incl. GST)**	Last Date and Time for payment of Tender Participation Fee
TPCODL/P&S/ 1000000541/ 23-24	Pan Area TPCODL	Engineering, Supply, Installation Testing and Commissioning of River Crossing work on Turnkey Basis	2,00,000	5,000	25.01.2024

\* EMD is exempted for MSMEs registered in the State of Odisha.

\*\* MSMEs registered in the State of Odisha shall pay tender fee of Rs. 1,000/- including GST.

For details of MSME norms, pls refer "Annexure VII-a"

**Note: Bidders must participate in all scope of work.**

**Please note that corresponding details mentioned in this document will supersede any other details mentioned anywhere else in the Tender Document.**

### 1.2. Availability of Tender Documents

Tender documents may be downloaded by interested eligible bidders from TPCODL website [www.tpcentralodisha.com](http://www.tpcentralodisha.com) with effect from 20<sup>th</sup> January 2024. In the event of detailed tender documents are downloaded from TPCODL website, the Tender Fee shall be compulsorily submitted either online through NEFT/ RTGS or demand draft/ Banker's Cheque drawn in favor of "TP Central Odisha Distribution Limited", payable at Bhubaneswar only. Any such bid submitted without this Fee shall be rejected.

Bidders are requested to visit TPCODL website [www.tpcentralodisha.com](http://www.tpcentralodisha.com) regularly for any modification/ clarification to the bid documents.

**TP CENTRAL ODISHA DISTRIBUTION LIMITED**  
(A Tata Power & Odisha Govt. joint venture)

2nd Floor, IDCO Tower, Janpath Bhubaneshwar, Odisha 751022

### 1.3. Calendar of Events

(a)	Date of sale/ availability of tender documents from TPCODL Website	20-01-2024
(b)	Last date and time of Payment of Tender Fee	<b>25-01-2024, 17:00 Hrs.</b>
(c)	Last Date of receipt of pre-bid queries, if any in <b>MS –Excel</b> format through e-mail, (if any) <b>after which no queries will be entertained</b>	01-02-2024
(d)	Last Date of Posting Consolidated replies to all the pre-bid queries as received	06-02-2024
(e)	Last date and time of receipt of Bids	12-02-2024 up to 17:00 Hrs.
(f)	Date & Time of opening technical bids and EMD (Envelope-1 & 2)	12-02-2024

**Note:** In the event of last date specified for submission of bids and date of opening of bids is declared as a closed holiday for TPCODL's office, the last date of submission of bids and date of opening of bids will be the day following working day at appointed times.

For further details of Tenders, please visit Vendor Zone on TPCODL website <https://www.tpcentralodisha.com>. Future communication/corrigendum to tender documents, if any, shall be available on website. The authority reserves the right to accept or reject any or whole of the offers without assigning any reason thereof.

### 1.4 Mandatory documents required along with the Bid

- 1.4.1 EMD of requisite value and validity
- 1.4.2 Tender Fee in case the tender is downloaded from website
- 1.4.3 Requisite Documents for compliance to Qualification Criteria mentioned in Clause 1.7.
- 1.4.4 Drawing, Type Test details along with a sample of each item as specified at Annexure I (as applicable)
- 1.4.5 Duly signed and stamped 'Schedule of Deviations' as per Annexure III on bidder's letter head.
- 1.4.6 Duly signed and stamped 'Schedule of Commercial Specifications' as per Annexure IV on bidder's letter head.
- 1.4.7 Proper authorization letter/ Power of Attorney to sign the tender on the behalf of bidder.
- 1.4.8 Copy of PAN, GST, PF and ESI Registration (In case any of these documents is not available with the bidder, same to be explicitly mentioned in the 'Schedule of Deviations')

**Please note that in absence of any of the above documents, the bid submitted by a bidder shall be liable for rejection.**

### 1.5. Deviation from Tender

Normally, the deviations to tender terms are not admissible and the bids with deviation are liable for rejection. Hence, the bidders are advised to refrain from taking any deviations on this Tender. Still in case of any deviations, all such deviations shall be set out by the Bidders, clause by clause in the 'Annexure III - Schedule of Deviations' and same shall be submitted as a part of the Technical Bid.

### 1.6. Right of Acceptance/Rejection

Bids are liable for rejection in absence of following documents:

- i. EMD of requisite value and validity
- ii. Tender fee of requisite value
- iii. Price Bid as per the Price Schedule mentioned in Annexure I (BOQ)

**TP CENTRAL ODISHA DISTRIBUTION LIMITED**  
(A Tata Power & Odisha Govt. joint venture)

2nd Floor, IDCO Tower, Janpath Bhubaneshwar, Odisha 751022

- iv. Necessary documents against compliance to Qualification Requirements mentioned at Clause 1.7 of this Tender Document
- v. Filled in Schedule of Deviations as per Annexure III
- vi. Filled in Schedule of Commercial Specifications as per Annexure IV
- vii. Receipt of Bid within the due date and time

TPCODL reserves the right to accept/reject any or all the bids without assigning any reason thereof.

**1.7 Qualification Criteria**

**1.7.1 TECHNICAL REQUIREMENT:**

This bid is open to any EPC / Turnkey Contractor domicile in India independently, who meets the following Technical qualifying requirement;

- A) The bidder must have executed, tested and commissioned similar job as mentioned in tender doc. for Engineering, Supply, Erection Testing & Commissioning on Turnkey basis in any utility/companies
- B) The bidder should have completed at least one river crossing work.
- C) The Bidder must upload copies of the relevant Work Orders along with Handing Over and Taking Over Certificate or Client certified copies of Completion Certificate in proof of successful execution of Works and Performance Certificates duly signed by the competent authority of the Client in proof of successful operation of the above quantum of works from any utility/companies in India. The works experience schedule shall be as per pro forma given here under.

**“Work Experience Schedule”**

Work Order Ref.				Sub-Stations/Lines Installed, Erected & Commissioned			
Sl. No.	FY	Name of the Client	Work Order Ref (No. & Date)	Qty of relevant scope	Date of Completion of Commissioning	Documents provided in proof of having completed the works and/or of successful operation as the case may be. (As Attachment)	

Supporting documents in favour of the above mentioned requirement shall have to be submitted/ uploaded by the Bidder as an attachment to the e-tender folder. Failure to furnish/upload any or all information as required as a part of Bid document in all respect will be at the Bidder’s risk and may result in rejection of the Bid.

**1.7.2 BIDDER’S FINANCIAL QUALIFICATION:**

**1. MINIMUM AVERAGE ANNUAL TURNOVER (MAAT) :**

The average annual turnover of the bidder for the past Three FY (i.e FY 20-21, FY 21-22 and FY 2022-23) shall be a minimum of Rs.3 Cr. Copy of audited Balance Sheet and P&L Account to be submitted in this regard.

The bidder should be a firm registered/incorporated under Companies Act, 1956 or Companies Act, 2013, and further amendment (s)

**TP CENTRAL ODISHA DISTRIBUTION LIMITED****(A Tata Power & Odisha Govt. joint venture)**

2nd Floor, IDCO Tower, Janpath Bhubaneshwar, Odisha 751022

(Photocopy of Certificate of Incorporation issued by the Registrar of Companies)

OR

a registered partnership firm (registered under section 59 of the Partnership Act, 1932), (Photocopy of registered Partnership Deed)

OR

a limited liability partnership (under the Limited Liability Partnership Act, 2002), (Photocopy of the LLP Registration Certificate issued by Registrar of Companies)

OR

a Proprietorship firm. ("Photocopy of Certificate/license issued by municipal authorities under Shop & Establishment Act. Or Complete ITR (including computation of income) in the name of Proprietor. Or Relevant documents issued by Central/State Government authority/department etc.)

**1.7.3 BIDDER'S PERFORMANCE QUALIFICATION:**

1. The bidders or Holding / Associate / Subsidiary Companies or its any group company who have earlier failed to execute even any order of the TPCODL / Odisha Discom/ Govt. Of Odisha /Govt. funded Project or who stand currently debarred / blacklisted by TPCODL / Govt. Of Odisha/any other Distribution / Transmission / Generation Utility in India shall not be eligible to participate in this tender.
2. The bidder should not have any pending litigation with TPCODL with regard to any project or related activity. The Bid furnished by the bidder shall not be eligible for consideration if it is not accompanied by the Affidavit. Further, the Bid/LOA/LOI shall be liable for outright rejection/ cancellation at any stage if any information contrary to the affidavit is detected.

**Note:**

The bidder should certify/ declare the same in unequivocal terms by way of an affidavit duly sworn before a Notary. Failure to furnish/upload any or all information as required as a part of Bid document in all respect will be at the Bidder's risk and may result in rejection of the Bid.

**1.7.4. OTHERS:**

1. Bidder should have a **valid HT/ EHT Electrical license** issued by Govt. of Odisha for carrying out electrical works in Odisha Copy of license required. In case bidder is not having HT Electrical license issued by Govt. of Odisha should have HT Electrical license issued by Electrical licensing department other state government / Union territory, they shall submit an undertaking that, in case they are successful bidder, license shall be obtained within 1 months after award of contract. They shall submit a copy of such application with copy of challans for payment of required fees to appropriate authority in Odisha **within 15 days after award of the contract**. This is a statutory requirement for any Electrical Contractor to work in Odisha.
2. Bidder must have all statutory compliance like valid PAN, ESI registration, EPF registration and GSTN registration, Certificate of Incorporation.

**TP CENTRAL ODISHA DISTRIBUTION LIMITED**

(A Tata Power &amp; Odisha Govt. joint venture)

2nd Floor, IDCO Tower, Janpath Bhubaneshwar, Odisha 751022

**Note :**

- ❖ **The evaluation of contractor's safety capability with evaluation of safety bid is part of qualifying requirement for this work.**
- ❖ **Evaluation of Bidder capacity is part of part-I evaluation. TPCODL have right to reject any bid, at any time with or without assigning notice or reason thereof.**
- ❖ **Joint venture/ consortium is not accepted in the tender.**

TPCODL reserves the right to relax qualification criteria without assigning any reason thereof. TPCODL reserves the right to accept or reject any bid at any time without assigning reason what so ever may be.

**1.8. Marketing Integrity**

We have a fair and competitive marketplace. The rules for bidders are outlined in the General Condition of Contracts. Bidders must agree to these rules prior to participating. In addition to other remedies available, TPCODL reserves the right to exclude a bidder from participating in future markets due to the bidder's violation of any of the rules or obligations contained in the General Condition of Contracts. A bidder who violates the market place rules or engages in behavior that disrupts the fair execution of the marketplace, may result in restriction of a bidder from further participation in the marketplace for a length of time, depending upon the seriousness of the violation. Examples of violations include, but are not limited to:

- Failure to honor prices submitted to the marketplace
- Breach of terms as published in TENDER/NIT

**1.9. Supplier Confidentiality**

All information contained in this tender is confidential and shall not be disclosed, published or advertised in any manner without written authorization from TPCODL. This includes all bidding information submitted to TPCODL. All tender documents remain the property of TPCODL and all suppliers are required to return these documents to TPCODL upon request. Suppliers who do not honor these confidentiality provisions will be excluded from participating in future bidding events.

**2.0 Evaluation Criteria**

- The bids will be evaluated technically on the compliance to tender terms and conditions.
- The bids will be evaluated commercially on overall all-inclusive price of tender BOQ of whole package/scope as calculated in Schedule of Items [Annexure I]. TPCODL reserves the right to split the order line item wise and / or quantity wise or/ scope wise or / Location wise.
- The Contract will be split maximum to 5 Nos. qualified bidder. Hence, all bidders are advised to quote their most competitive rates.
- Bidder has to mandatorily quote as per schedule of item [Annexure-I]. Failing to do so TPCODL may reject the bid.

**NOTE:** In case a new bidder is not registered with TPCODL, factory inspection and evaluation shall be carried out to ascertain bidder's manufacturing capability and quality procedures. However, TPCODL reserves the right to carry out factory inspection and evaluation for any bidder prior to technical qualification.

In case a bidder is found as Disqualified in the factory evaluation, their bid shall not be evaluated any further and shall be summarily rejected. The decision of TPCODL shall be final and binding on the bidder in this regard.



**TP CENTRAL ODISHA DISTRIBUTION LIMITED**

(A Tata Power &amp; Odisha Govt. joint venture)

2nd Floor, IDCO Tower, Janpath Bhubaneswar, Odisha 751022

**2.1 Price Variation Clause:** The prices shall remain firm during the entire contract period.

**2.2 Quantity variation Clause:** There will not be any guarantee on quantity of job. Job has to be carried out on as and when required basis order from TPCODL on the quantity to be specified in the order.

**3.0 Submission of Bid Documents****3.1 Bid Submission**

Bidders are requested to submit their offer in line with this Tender document through e-tendering process.

Please note all future correspondence regarding the tender, bid submission, bid submission date extension, Pre-bid query etc. will happen only through TPCODL E-Tender system (Ariba).

No e-mail or verbal correspondence will be responded. All communication will be done strictly with the bidder who have done the above step to participate in the Tender.

Bids shall be submitted in 4 (four) parts:

**FIRST PART: "EMD"** as applicable shall be submitted. The EMD shall be valid for 210 days from the due date of bid submission in the form of Bank Guarantee / Bank Draft / Bankers Pay Order (issued from a Scheduled Bank) online NEFT/ RTGS transfer favoring 'TP Central Odisha Distribution Limited' payable at Bhubaneswar. The EMD has to be strictly in the format as mentioned in General Condition of Contract, failing which it shall not be accepted by TPCODL and the bid as submitted shall be liable for rejection. A separate non-refundable tender fee of stipulated amount also needs to be transferred online through NEFT/ RTGS in case the tender document is downloaded from our website.

TPCODL Bank Details for transferring Tender Fee and EMD is as below:

**Account Name: TP CENTRAL ODISHA DISTRIBUTION LIMITED**  
**Bank Name: SBI, IDCO Towers, Bhubaneswar**  
**Bank Account No.: 10835304915**  
**IFSC Code: SBIN0007891**

**Note-** EMD is preferred in form of Bank Guarantee and to be delivered at the following address. However, in view of present situation if Bidder is finding it difficult to make and submit BG for EMD amount, they can do online transfer of EMD amount in the above mentioned Account and submit proof of the same as part of Bid Submission.

Please note that in such case, Tender Fee and EMD should be strictly 2 separate transactions.

Please note as return of EMD from Bank Account is non-standard practice the same may take more time than return of EMD BG.

**EMD Original Hard Copy shall be delivered at the following address in Envelope clearly indicating Tender Reference/ Enquiry Number, Name of Tender and Bidder Name**

**Chief (Procurement & Stores)**  
**TP Central Odisha Distribution Limited**  
**2<sup>nd</sup> Floor, IDCO Towers, Janpath, Bhubaneswar- 751022**

**SECOND PART: "TECHNICAL BID"** shall contain the following documents:

- Documentary evidence in support of qualifying criteria
- Technical literature/GTP/Type test report etc. (if applicable)
- Qualified manpower (if available)
- Testing facilities (if applicable)
- No Deviation Certificate as per the Annexure III – Schedule of Deviations

**TP CENTRAL ODISHA DISTRIBUTION LIMITED**  
(A Tata Power & Odisha Govt. joint venture)

2nd Floor, IDCO Tower, Janpath Bhubaneshwar, Odisha 751022

- f) Acceptance to Commercial Terms and Conditions viz. Delivery schedule/period, payment terms etc. as per the Annexure IV – Schedule of Commercial Specifications.
- g) Quality Assurance Plan/Inspection Test Plan for supply items (if applicable)

**The technical bid shall be properly indexed and is to be submitted through TPCODL E-tender System (Ariba) only. Hard Copy of Technical Bids need not be submitted.**

**THIRD PART (Safety Bid):** Bidder shall mention the details as required in the safety bid form (As mentioned in annexure- IX). Bidder also has to submit the relevant documents for the same as required by TPCODL

**FOURTH PART: “PRICE BID”** shall contain only the price details and strictly in format as mentioned in Annexure I along with explicit break up of basic prices, Taxes & duties, Freight etc. In case any discrepancy is observed between the item description stated in Schedule of Items mentioned in the tender and the price bid submitted by the bidder, the item description as mentioned in the tender document (to the extent modified through Corrigendum issued if any) shall prevail.

**Price Bid is to be submitted in soft copy through TPCODL E-Tendering system (Ariba) only. Hard copy of Price Bid not be submitted.**

The EMD in the form of Bank Draft / BG / Bankers Pay Order shall be submitted in original hard copy and then placed in sealed envelope which shall be clearly marked as below:

EMD

**“OPEN TENDER NOTIFICATION FOR Rate Contract for “One Year Rate Contract “Engineering, Supply, Installation, Testing & Commissioning of River Crossing work on Turnkey Basis Through PC+6, UR+6 & H Pole DP Structure” under Capex/Govt. Funded/Deposit work etc. TPCODL Jurisdiction**

The Bid prepared by the Bidder, and all correspondence and documents relating to the Bid exchanged by the Bidder and the TPCODL, shall be written in the English Language. Any printed literature furnished by the Bidder may be written in another Language, provided that this literature is accompanied by an English translation, in which case, for purposes of interpretation of the Bid, the English translation shall govern.

**SIGNING OF BID DOCUMENTS:**

The bid must contain the name, residence and place of business of the person or persons making the bid and must be signed and sealed by the Bidder with his usual signature. The names of all persons signing should also be typed or printed below the signature.

The Bid being submitted must be signed by a person holding a Power of Attorney authorizing him to do so, certified copies of which shall be enclosed.

The Bid submitted on behalf of companies registered with the Indian Companies Act, for the time being in force, shall be signed by persons duly authorized to submit the Bid on behalf of the Company and shall be accompanied by certified true copies of the resolutions, extracts of Articles of Association, special or general Power of Attorney etc. to show clearly the title, authority and designation of persons signing the Bid on behalf of the Company. Satisfactory evidence of authority of the person signing on behalf of the Bidder shall be furnished with bid.

A bid by a person who affixes to his signature the word ‘President’, ‘Managing Director’, ‘Secretary’, ‘Agent’ or other designation without disclosing his principal will be rejected.

The Bidder’s name stated on the Proposal shall be the exact legal name of the firm.

**TP CENTRAL ODISHA DISTRIBUTION LIMITED**  
(A Tata Power & Odisha Govt. joint venture)

2nd Floor, IDCO Tower, Janpath Bhubaneshwar, Odisha 751022

**3.2 Contact Information**

All the bidders are requested to send their pre-bid queries (if any) against this tender through e-mail within the stipulated timelines. The consolidated reply to all the queries received shall be posted on TPCODL website by the stipulated timelines as detailed in calendar of events.

**Communication Details:**Handling Team Lead for this Tender:

Name: Gaurav Singh  
Contact No.: 9205190016  
E-Mail ID: [gaurav.singh@tpcentralodisha.com](mailto:gaurav.singh@tpcentralodisha.com)

Senior General Manager (Material Procurement):

Name: Mr.Sudhakar Behara Sr.GM  
Contact No.: 9437282663  
E-Mail ID: [Sudhakar.behara@tpcentralodisha.com](mailto:Sudhakar.behara@tpcentralodisha.com)

**3.3 Bid Prices**

Bidders shall quote for the entire Scope of Supply/ work with a break up of prices for individual items and Taxes & duties. The bidder shall complete the appropriate Price Schedules included herein, stating the Unit Price for each item & total price with taxes, duties & freight up to destination at various sites of TPCODL. The all-inclusive prices offered shall be inclusive of all costs as well as Duties, Taxes and Levies paid or payable during the execution of the supply work, breakup of price constituents.

**Applicable GST to be specified clearly.**

The quantity break up shown else-where other than Price Schedule is tentative. The bidder shall ascertain himself regarding material required for completeness of the entire work. Any items not indicated in the price schedule but which are required to complete the job as per the Technical Specifications/ Scope of Work/ SLA mentioned in the tender, shall be deemed to be included in prices quoted.

**3.4 Bid Currencies**

Prices shall be quoted in Indian Rupees Only.

**3.5 Period of Validity of Bids**

Bids shall remain valid for 180 days from the due date of submission of the bid.

Notwithstanding clause above, the TPCODL may solicit the Bidder's consent to an extension of the Period of Bid Validity. The request and responses thereto shall be made in writing.

**3.6 Alternative Bids**

Bidders shall submit Bids, which comply with the Bidding documents. Alternative bids will not be considered. The attention of Bidders is drawn to the provisions regarding the rejection of Bids in the terms and conditions, which are not substantially responsive to the requirements of the bidding documents.

**3.7 Modifications and Withdrawal of Bids**

The bidder is not allowed to modify or withdraw its bid after the Bid's submission. The EMD as submitted along with the bid shall be liable for forfeiture in such event.

**3.8 Earnest Money Deposit (EMD)**

The bidder shall furnish, as part of its bid, an EMD amounting as specified in the tender. The EMD is required to protect TPCODL against the risk of bidder's conduct which would warrant forfeiture.

The EMD shall be denominated in any of the following form:

**TP CENTRAL ODISHA DISTRIBUTION LIMITED**  
(A Tata Power & Odisha Govt. joint venture)

2nd Floor, IDCO Tower, Janpath Bhubaneshwar, Odisha 751022

- Banker's Cheque/ Demand Draft/ Pay order drawn in favor of TP Central Odisha Distribution Limited payable at Bhubaneswar.
- Online transfer of requisite amount through NEFT/ RTGS.
- Bank Guarantee valid for 210 days after due date of submission.

**The EMD shall be forfeited in case:**

a) The bidder withdraws its bid during the period of specified bid validity.

**Or**

- b) The successful Bidder does not
- a) accept the Purchase Order, or
  - b) furnish the required Performance Security Bank Guarantee

**3.9 Type Tests (if applicable)**

The type tests specified in TPCODL specifications should have been carried out within five years prior to the date of opening of technical bids and test reports are to be submitted along with the bids. If type tests carried out are not within the five years prior to the date of bidding, the bidder will arrange to carry out type tests specified, at his cost. The decision to accept/ reject such bids rests with TPCODL.

**4 Bid Opening & Evaluation process**

**4.1. Process to be confidential**

Information relating to the examination, clarification, evaluation and comparison of Bids and recommendations for the award of a contract shall not be disclosed to Bidders or any other persons not officially concerned with such process. Any effort by a Bidder to influence the TPCODL's processing of Bids or award decisions may result in rejection of the Bidder's Bid.

**4.2. Technical Bid Opening**

Bids will be opened at TPCODL Office, Bhubaneswar. All tender bids shall be opened internally by TPCODL. Presence of any bidder will not be allowed during bid opening process. Technical bid must not contain any cost information whatsoever.

First the envelope marked "EMD" will be opened. Bids without EMD/cost of tender (if applicable) of required amount/ validity in prescribed format, shall be rejected.

Next, the technical bid of the bidders who have furnished the requisite EMD will be opened, one by one.

**4.3. Preliminary Examination of Bids/Responsiveness**

TPCODL will examine the Bids to determine whether they are complete, whether any computational errors have been made, whether required sureties have been furnished, whether the documents have been properly signed, and whether the Bids are generally in order. TPCODL may ask for submission of original documents in order to verify the documents submitted in support of qualification criteria.

Arithmetical errors will be rectified on the following basis: If there is a discrepancy between the unit price and the total price per item that is obtained by multiplying the unit price and quantity, the unit price shall prevail and the total price per item will be corrected. If there is a discrepancy between the Total Amount and the sum of the total price per item, the sum of the total price per item shall prevail and the Total Amount will be corrected.

Prior to the detailed evaluation, TPCODL will determine the substantial responsiveness of each Bid to the Bidding Documents including production capability and acceptable quality of the Goods offered. A substantially responsive Bid is one, which conforms to all the terms and conditions of the Bidding Documents without material deviation.

Bid determined as not substantially responsive will be rejected by the TPCODL and may not subsequently be made responsive by the Bidder by correction of the non-conformity.

**TP CENTRAL ODISHA DISTRIBUTION LIMITED**  
(A Tata Power & Odisha Govt. joint venture)

2nd Floor, IDCO Tower, Janpath Bhubaneshwar, Odisha 751022

#### 4.4. Techno Commercial Clarifications

Bidders need to ensure that the bids submitted by them are complete in all respects. To assist in the examination, evaluation and comparison of Bids, TPCODL may, at its discretion, ask the Bidder for a clarification on its Bid for any deviations with respect to the TPCODL specifications and attempt will be made to bring all bids on a common footing. All responses to requests for clarification shall be in writing and no change in the price or substance of the Bid shall be sought, offered or permitted owing to any clarifications sought by TPCODL.

#### 4.5. Price Bid Opening

Price bids will be opened internally without the presence of any bidder representative. The EMD of the bidder withdrawing or substantially altering his offer at any stage after the technical bid opening will be forfeited at the sole discretion of TPCODL without any further correspondence in this regard.

#### 4.6. Reverse Auctions

TPCODL reserves the right to conduct the reverse auction (instead of public opening of price bids) for the products/ services being asked for in the tender. The terms and conditions for such reverse auction events shall be as per the Acceptance Form attached as Annexure VI of this document. The bidders along with the tender document shall mandatorily submit a duly signed copy of the Acceptance Form attached as Annexure VI as a token of acceptance for the same.

#### 5.0 Award Decision

TPCODL will award the contract to the successful bidder whose bid has been determined to be the lowest-evaluated responsive bid as per the Evaluation Criterion. The Cost for the said calculation shall be taken as the all-inclusive cost quoted by bidder in Annexure I (Schedule of Items) subject to any corrections required in line with Clause 4.3 above. The decision to place rate contract / purchase order / LOI solely depends on TPCODL on the cost competitiveness across multiple lots, quality, delivery and bidder's capacity, in addition to other factors that TPCODL may deem relevant.

TPCODL reserves all the rights to award the order/issue of RO as per field requirement and sanctioned of Govt. fund time to time to carry out the work scope under scheme "SDMF-I". Also TPCODL reserves the right to split the contract full or part.

In case performance of the bidder is found unsatisfactory during the delivery/execution process, the award will be cancelled and TPCODL reserves the right to award other performing bidder who are found fit.

#### 6.0 Order of Preference/Contradiction:

In case of contradiction in any part of various documents in tender, following shall prevail in order of preference:

1. Schedule of Items (Annexure I)
2. Post Award Contract Administration (Clause 7.0)
3. Submission of Bid Documents (Clause 3.0)
4. Scope of work and SLA
5. Technical specification
6. Acceptance form for participation in reverse auction
7. General Conditions of Contract

#### 7.0 Post Award Contract Administration

- 7.1.1 AWARD OF CONTRACT:** After finalization of tender, Rate Contract shall be issued on successful bidder with a validity period of **12 Months**. The Contractor shall complete the Survey of the assigned project jointly with authorized person(s) / agency of TPCODL & submit Substation wise Joint Survey Report along with SLD, Substation wise BOQ & proposed work completion Schedule to TPCODL for approval within 30 days of issue of RC. The Work Completion Schedule should consist of Key Mile Stones covering entire scope of work such as engineering, procurement, manufacturing, shipment and field erection activities including Civil works in line with the Work Completion Schedule of TPCODL. After



**TP CENTRAL ODISHA DISTRIBUTION LIMITED**  
(A Tata Power & Odisha Govt. joint venture)

2nd Floor, IDCO Tower, Janpath Bhubaneshwar, Odisha 751022

approval of above reports by TPCODL, Substation wise Release Orders shall be issued to the Contractor basing on the approved BOQ. The Contractor shall take all efforts to complete the Project within scheduled Time.

- 7.1.2 BA is required to visit the site to understand entire scope of work & prepare BOQ & quote accordingly. BA is required to carry out the soil investigation for finalising the tower civil foundation drawing. BA will carry out the necessary engineering. Design for tower erection & will submit the detailed calculation along with drawing to TPCODL for approval.
- 7.1.3 Supply will be done as per TPCODL approved vendor list. Before installing material BA has to approve the GTP & drawing from TPCODL.
- 7.1.4 **BA is required to dismantle of existing structure if any to erect new structure as required and handover of the dismantled material to TPCODL store .**
- 7.1.5 **PRICES/ RATES/ TAXES:** The Contract price comprising of Supply, Installation, Testing and Commissioning shall remain **FIRM** during the entire Contract period except statutory variation in Taxes, which shall be to the account of TPCODL against Tax Invoice. However, the price shall **remain firm until the completion of the Project**, even if contract period is extended due to any reason. There shall be no price variation during the Contract Period / Extended Contract Period.
- 7.1.6 **PROJECT COMPLETION PERIOD: Work completion** Period shall be **6 Months form date of issue of RO**. The work completion period shall be revised if the reason of delay in completion of works is not attributable to the Contractor. L-1 Schedule (Submission of Activity wise Milestones to complete the project within scheduled time line) shall be furnished with the Bid documents. The Supply shall sequential and as per agreed milestones
- 7.1.7 **PERFORMANCE GUARANTEE:** The Contractor shall guarantee that the equipment/materials will be new, unused and in accordance with the Contract documents and free from defects in material and workmanship for a period of **24 (Twenty Four) months commencing immediately after the satisfactory commissioning and handing over of the entire works of the under the Contract (except major materials)**. The Contractor's liability shall be to the extent of repair/replacement of such defective equipment/material either arising from faulty design or defective equipment/materials and/or bad workmanship. Such defective equipment/materials shall be handed over to the Contractor for repair or replacement by a new one, unless otherwise repairable at site. The Contractor shall complete the repair/replacement work within the reasonable time frame intimated by the Engineer-In-Charge. For **major equipment (13 Mtr./14 Mtr. H Pole, Isolator, Insulator, PC+6 Tower, UR+6 Tower, AAC Conductor etc.)** and its workmanship, the Contractor shall provide **guarantee of 60 (Sixty) Months commencing immediately after the satisfactory commissioning and handing over of the entire works of the under the Contract**. If any defects are not remedied within the time frame, the Engineer-In-Charge may proceed to do the work at the Contractor's risk and cost. In the event of any emergency, where in the judgment of the Engineer-In-Charge, delay would cause serious loss or damages, repair may be made by the Engineer-In-Charge or a third party chosen by the Engineer-In-Charge without advance notice to the Contractor and the cost of such work shall be recovered from the Contractor. In the event such action is taken by the Engineer-In-Charge, the Contractor will be notified in due course and he shall assist wherever possible in making necessary corrections. This shall not relieve the Contractor of his liabilities under the terms and conditions of the Contract. The repaired or new parts will be supplied and erected free of cost by the Contractor. If any repair is carried out on his behalf at the site, the Contractor shall bear the cost of such repairs.
- 7.1.8 **CONTRACT PERFORMANCE BANK GUARANTEE:** The successful Bidder shall be required to furnish **two Contract Performance Bank Guarantee** in non-judicial stamp paper of appropriate value (as per the prescribed format) issued in favour of "TP Central Odisha Distribution Ltd." encashable at

**TP CENTRAL ODISHA DISTRIBUTION LIMITED**

(A Tata Power &amp; Odisha Govt. joint venture)

2nd Floor, IDCO Tower, Janpath Bhubaneshwar, Odisha 751022

Bhubaneswar Branch of the Issuing Bank only within **30 (Thirty) days from the date of issue of the Release Order.**

**First BG :** The Contract Performance Bank Guarantee (CPBG) amount shall be equal to **Five percent (5%)** of the Contract Price (including GST) of each **Release Order** related Major items i.e (**13 Mtr/14 Mtr. H Pole, Isolator, PC+6 Tower, UR+6 Tower, AAAC Conductor etc.**) valid for 03 (three) Months over and above work completion period (SITC) plus Guarantee Period i.e. (**6 months (SITC) + 60 Months (Guarantee Period)+3 Months (Claim Period) = 69 months**).

**Second BG :** The Contract Performance Bank Guarantee (CPBG) amount shall be equal to **Five percent (5%)** of the Contract Price (including GST) for each **Release Order** related minor items (excluding cost of major items as above) valid for 03 (three) Months over and above work completion period (SITC) plus Guarantee Period i.e. (**6 months (SITC) + 24 Months (Guarantee Period) +3 Months (Claim Period) = 33 months**).

If the work completion period gets extended the Contract Performance Bank Guarantee shall be extended accordingly. In case the contract price gets revised, the successful bidder shall submit the amended Bank Guarantee to that effect.

The aforesaid CPBG shall be returned to the Contractor after successful completion of the guaranteed obligations under the contract.

**7.1.9 LATENT DEFECT WARRANTY:** The period of latent defect warranty shall be **5 years reckoned from the date of completion of guarantee period** commencing immediately after the satisfactory commissioning for the entire works under the contract.

The latent defect warranty shall mean such warranties which are 'Latent' to the equipment supplied or erected which would not normally be discovered/seen by an inspection nor discoverable during the trial run.

These are concealed flaws which one would normally not expect from the item during the execution of the contract or during the guarantee period but subjected from a manufacturing defect for which the contractor shall remain liable for replacement/rectification for such 'Latent' defect.

OWNER shall exercise the right of latent defect warranty for replacement/rectification of Supply/Workmanship. OWNER will have a claim in damages against the contractor if the defects are a result of the Contractor's breach of contract and/or negligence and OWNER suffers loss as a result.

**7.1.10 LIQUIDATED DAMAGE / PENALTY:** If the Contractor fails to supply the Materials/Equipment or fails to complete the erection including civil works within the due date of agreed key mile stones as defined in the Works Completion Schedule, TPCODL has the right to levy LD **@0.5% for each week** of delay or part thereof of the contract price of un-finished portion of works subject to the maximum of **5% (five percent) of the total contract price.**

**7.1.11 SUMITTAL & INSPECTION AND TESTING:** The time line to submit the GTP & drawing materials (**13 Mtr/14 Mtr. H Pole, Isolator, Insulator, PC+6 Tower, UR+6 Tower, AAAC Conductor etc.**) shall be submitted within 5 days and balance materials within 15 days after receiving of RC/ LOI. Also, BA shall have to submit layout within 10days.

TPCODL reserves the right to carry out material / services inspection through Third Party Inspecting Agency (TPIA) and or TPCODL or any authorized representative of OWNER at the Contractor's or its Vendor's manufacturing works. The Contractor shall give the advance notice in writing about the place of Inspection and/or Testing at least 15 days before the schedule date on which the equipment/materials will be ready for Inspection and/or Testing.



**TP CENTRAL ODISHA DISTRIBUTION LIMITED**  
(A Tata Power & Odisha Govt. joint venture)

2nd Floor, IDCO Tower, Janpath Bhubaneshwar, Odisha 751022

The Engineer-In-Charge shall have the right to re-inspect any equipment/materials though previously inspected and approved by him at the Contractor's or its Vendor's works, before and after the same are erected at Site. If by the above inspection, TPCODL rejects any equipment, the Contractor shall make good for such rejections either by replacement or modifications/repairs as may be necessary to the satisfaction of the Engineer-In-Charge, free of cost. Such replacement will also include the replacements or re-execution of such of those works of other Contractors and/or agencies, which might have got damaged or affected by the replacements or re-work done to the Contractor's/Vendor's work.

- 7.1.12 INSPECTION COST:** Expenses in respect of witnessing the Inspection & Testing of the equipment / materials offered by the Contractor, at the inspection and testing site, will be to the account of TPCODL. However if re-inspection of same materials is required due to any non-compliance, Additional cost of such re-inspection, if any, shall be borne by the Contractor.

EPC contractor is responsible for arranging the Electrical Inspectorate Clearance and it should be in his purview to get it done. TPCODL will facilitate the process for getting clearance and reimburse the Statutory Fee on production of receipts for such payment.

- 7.1.13 STORE & STORAGE INSURANCE :**The Contractor shall make his own arrangements for land for Stores and Workshops as required for storage of materials supplied and brought to site under the Contract at his own cost. The Contractor shall bring to Site all Construction equipment, tools and tackles for the purpose of the works.

He shall also employ necessary **watch and ward establishment** for the purpose.

All the equipment and materials including spares being supplied by the Contractor shall be kept completely **insured** by the Contractor at his cost from time of dispatch from the Contractor's works / Vender's works, up to the completion of erection, testing & commissioning and taking over of the entire works in accordance with the Contract.

- 7.1.14 SURPLUS MATERIALS/EQUIPMENT:**Bidder shall plan & execute the Contract in a manner such that no surplus materials/Equipment is accumulated after completion of the Contract.

Surplus Materials/Equipment including construction surplus of the civil works arising out of the contract, if any, the same shall be taken back by the Contractor without any cost to TPCODL.

- 7.1.15 RIGHT OF WAY:**The responsibilities of acquiring Right of Way (ROW) lies with contractor at his risk and cost. However, TPCODL will facilitate process of securing the ROW. The Acquisition of land for Sub- Stations shall be the sole responsibility of TPCODL. Whereas the Contractor shall be responsible for securing the RoW for lines work. Similarly, responsibilities of getting clearance from Railway, NHAI, Forest, Water and other Statutory/Govt. bodies lie with the contractor at his risk and cost (except payment of statutory fees) . However, TPCODL will facilitate the process for getting clearance and reimburse the Statutory Fee on production of receipts for such payment. The Reinstatement of Roads if any (damaged during laying of UG Cable) & other RoW compensation are to the account of the EPC Contractor, however statutory fees paid, if any will be reimbursed by TPCODL.

- 7.1.16 EMBOSSING / PUNCHING / CASTING:** All equipment and materials supplied /erected under the Project shall bear distinct mark of "TPCODL/ SDMF I " by a way of embossing / punching / casting. This should be clearly visible to naked eye.

- 7.1.17 ELECTRICITY & WATER :**The Contractor shall be entitled to use for the purpose of performing the Services such supplies of electricity and water as may be available on the Site and shall provide any apparatus necessary for such use. The Contractor shall pay at the applicable tariff plus the overheads, if any, for such use. Where such supplies are not available, the Contractor shall make his own arrangement for provision of any supplies he may require.

**TP CENTRAL ODISHA DISTRIBUTION LIMITED**  
(A Tata Power & Odisha Govt. joint venture)

2nd Floor, IDCO Tower, Janpath Bhubaneshwar, Odisha 751022

**7.1.18 New Items :** In case any new item(s) are required during the execution of the Contract which are not available in the BOQ/Price Schedule contained initial RC issued after completion of this Tender, the same shall be executed by the Contractor at cost not exceeding the latest Benchmarking Price of TPCODL/other Tata Power managed Utilities in Odisha. In case the benchmarks are not available, the prices shall be mutually agreed.

**7.1.19 Payment Terms: (A)** 80% (Eighty percent) of contract price shall be paid on pro-rata basis along with taxes and duties within 30 days for completed items/work (Supply and erection at site only) against issued RO as per the agreed Bill of Materials subject to certification by TPCODL Engineer-in-charge.

**(B)** Balance 20% (Twenty percent) payment of the actual executed Work Order/RO shall be paid after completion of acceptance test and Taking Over of the complete systems specified in the order, including clearance of Electrical Inspection (if any), compliance thereof and reconciliation .

All other terms and conditions of TPCODL GCC shall be applicable.

The Contractor shall follow and comply with TPCODL Contractor Safety Management (CSM) and annual safety plan and applicable rules and regulation as per relevant safety guidelines i.e CEA 2010 safety guidelines, CEA 2010 construction guidelines etc., pertaining to the safety of workmen, employees, plant and equipment or as may be prescribed from time to time, without any demur, protest or contest or reservations.

## **7.2 Climate Change**

Significant quantities of waste are generated during the execution of project and an integrated approach for effective handling, storage, transportation and disposal of the same shall be adopted. This would ensure the minimization of environmental and social impact in order to combat the climate change. Please refer attached Environment Policy and Sustainability Policy, Annexure-XI for more details.

## **7.3 Ethics**

TPCODL is an ethical organization and as a policy TPCODL lays emphasis on ethical practices across its entire domain. Bidder should ensure that they should abide by all the ethical norms and in no form either directly or indirectly be involved in unethical practice.

TPCODL work practices are governed by the Tata Code of Conduct which emphasizes on the following:

- We shall select our suppliers and service providers fairly and transparently.
- We seek to work with suppliers and service providers who can demonstrate that they share similar values. We expect them to adopt ethical standards comparable to our own.
- Our suppliers and service providers shall represent our company only with duly authorized written permission from our company. They are expected to abide by the Code in their interactions with, and on behalf of us, including respecting the confidentiality of information shared with them.
- We shall ensure that any gifts or hospitality received from, or given to, our suppliers or service providers comply with our company's gifts and hospitality policy.
- We respect our obligations on the use of third party intellectual property and data.

Bidder is advised to refer Tata Code of Conduct (TCOC) attached at Annexure X for more information.

Any ethical concerns with respect to this tender can be reported to the following e-mail ID:

[purchase@tpcentralodisha.com](mailto:purchase@tpcentralodisha.com) / [pkjain@tatapower.com](mailto:pkjain@tatapower.com)

## **18. Specification and standards**

As per Annexure II

**TP CENTRAL ODISHA DISTRIBUTION LIMITED****(A Tata Power & Odisha Govt. joint venture)**

2nd Floor, IDCO Tower, Janpath Bhubaneshwar, Odisha 751022

**19. General Condition of Contract**

Any condition not mentioned above shall be applicable as per GCC Annexure-VIII attached along with this tender.

**20. Safety**

All jobs are this tender have to be executed strictly in compliance to the Safety terms and Conditions of TP Central Odisha Distribution Limited. Please refer attached Safety terms and conditions, Annexure-IX, for details. Violation of Safety norms will result in Penalty as mentioned in the above d

CONFIDENTIAL



NIT No.: TPCODL/P&S/1000000137/2020-21

**TP CENTRAL ODISHA DISTRIBUTION LIMITED**  
(A Tata Power & Odisha Govt. joint venture)

2nd Floor, IDCO Tower, Janpath Bhubaneshwar, Odisha 751022

**ANNEXURE I (Schedule of Items Attached Last page of the tender Document)**

\*Per River Crossing two No's of Support ( H-Pole/ UR+6/ PC+6 required)

\*\* The Tower weight mentioned in the BOQ shall be minimum weight

**Importance Note for Price Schedule:**

1. Price shall be quoted considering item description and technical specification.
2. The bidders are advised to quote prices strictly in the PRICE format given in Price Annexures. Failing to do so, bids are liable for rejection.
3. Bidder should quote as per the "Item description" column. No cutting/ overwriting in the prices is permissible.
4. Bidder have to quote against each items having Unit and Qty. No rate should be quoted where unit and Qty. are blank.
5. Mentioning "extra/inclusive" in any of the column may lead for rejection of the price bid.
6. If any price is mentioned against the line items where unit & Qty. is blank, then the quoted price against the line item will be ignored during evaluation.
7. Unit price of the price bid quoted by the bidder in his bid shall be considered and other than unit price i.e. items description, unit, qty., etc. shall be considered as per the TPCODL tender price schedule.
8. The bids will be evaluated commercially on the overall all-inclusive price of tender BOQ as Price Annexures.
9. All materials shall be supplied and erected by the BA on turnkey basis.
10. The unit price should be inclusive of freight, insurance and other levies (if any) and exclusive of GST. GST to be mentioned separately. Total price shall be inclusive of all.
11. The bidders advised to visit the site and understand scope of the work before price quotation.
12. The Bidder should ensure that the unit prices for the same item furnished in price schedules are consistent with each other. In case of any inconsistency in the Unit prices furnished in the price proposal of the bidder, the TPCODL have right to consider the lowest unit price in evaluation.
13. There shall be no price variation during the Contract Period / Extended Contract Period.

**TP CENTRAL ODISHA DISTRIBUTION LIMITED**  
(A Tata Power & Odisha Govt. joint venture)

2nd Floor, IDCO Tower, Janpath Bhubaneshwar, Odisha 751022

**ANNEXURE II**

**Technical Specification**

**Attached in Last Page of Tender Document**

CONFIDENTIAL

**TP CENTRAL ODISHA DISTRIBUTION LIMITED**

(A Tata Power &amp; Odisha Govt. joint venture)

2nd Floor, IDCO Tower, Janpath Bhubaneshwar, Odisha 751022

**ANNEXURE III****Schedule of Deviations**

Bidders are advised to refrain from taking any deviations on this TENDER. Still in case of any deviations, all such deviations from this tender document shall be set out by the Bidders, Clause by Clause in this schedule and submit the same as a part of the **Technical Bid**.

Unless **specifically** mentioned in this schedule, the tender shall be deemed to confirm the TPCODL's specifications:

Sr. No.	Clause No.	Tender Clause Details	Details of deviation with justifications

By signing this document we hereby withdraw all the deviations whatsoever taken anywhere in this bid document and comply to all the terms and conditions, technical specifications, scope of work etc. as mentioned in the standard document except those as mentioned above.

Seal of the Bidder:

Signature:

Name:

**TP CENTRAL ODISHA DISTRIBUTION LIMITED**

(A Tata Power &amp; Odisha Govt. joint venture)

2nd Floor, IDCO Tower, Janpath Bhubaneshwar, Odisha 751022

**ANNEXURE IV**
**Schedule of Commercial Specifications**

*(The bidders shall mandatorily fill in this schedule and enclose it with the offer Part I: Technical Bid. In the absence of all these details, the offer may not be acceptable.)*

S. No.	Particulars	Remarks
1.	Prices firm or subject to variation (If variable indicate the price variation clause with the ceiling if applicable)	Firm / Variable
1a.	If variable price variation on clause given	Yes / No
1b.	Ceiling	----- %
1c.	Inclusive of GST	Yes / No (If Yes, indicate % rate)
1d.	Inclusive of transit insurance	Yes / No
2.	Delivery	Weeks / months
3.	Guarantee clause acceptable	Yes / No
4.	Terms of payment acceptable	Yes / No
5.	Performance Bank Guarantee acceptable	Yes / No
6.	Liquidated damages clause acceptable	Yes / No
7.	Validity (180 days) (From the date of opening of bid)	Yes / No
8.	Inspection during stage of manufacture	Yes / No
9.	Rebate for increased quantity	Yes / No (If Yes, indicate value)
10.	Change in price for reduced quantity	Yes / No (If Yes, indicate value)
11.	Covered under Small Scale and Ancillary Industrial Undertaking Act 1992	Yes / No (If Yes, indicate, SSI Reg'n No.)

**Seal of the Bidder:**

**Signature:**

**Name:**



**TP CENTRAL ODISHA DISTRIBUTION LIMITED**  
(A Tata Power & Odisha Govt. joint venture)

2nd Floor, IDCO Tower, Janpath Bhubaneshwar, Odisha 751022

**ANNEXURE V****Checklist of all the documents to be submitted with the Bid**

Bidder has to mandatorily fill in the checklist mentioned below:

S. No.	Documents attached	Yes / No / Not Applicable
1	EMD of required value	
2	Tender Fee as mentioned in this tender	
3	Signed copy of this tender as an unconditional acceptance	
5	Duly filled schedule of commercial specifications (Annexure IV)	
6	Sheet of commercial/technical deviation if any (Annexure III)	
7	Balance sheet for the last completed three financial years; mandatorily enclosing Profit & loss account statement	
8	Acknowledgement for Testing facilities if available (duly mentioned on bidder letter head)	
9	List of Machine/tools with updated calibration certificates if applicable	
10	Details of order copy (duly mentioned on bidder letter head)	
11	Order copies as a proof of quantity executed	
12	Details of Type Tests if applicable (duly mentioned on bidder letter head)	
13	All the relevant Type test certificates as per relevant IS/IEC (CPRI/ERDA/other certified agency) if applicable	
14	Project/supply Completion certificates	
15	Performance certificates	
16	Client Testimonial/Performance Certificates	
17	Credit rating/solvency certificate	
18	Undertaking regarding non blacklisting (On company letter head)	
19	List of trained/untrained Manpower	

**Seal of the Bidder:****Signature:****Name:**

**TP CENTRAL ODISHA DISTRIBUTION LIMITED****(A Tata Power & Odisha Govt. joint venture)**

2nd Floor, IDCO Tower, Janpath Bhubaneshwar, Odisha 751022

**ANNEXURE VI****ACCEPTANCE FORM FOR PARTICIPATION IN REVERSE AUCTION EVENT***(To be signed and stamped by the bidder)*

In a bid to make our entire procurement process more fair and transparent, TPCODL intends to use the reverse auctions as an integral part of the entire tendering process. All the bidders who are found as technically qualified based on the tender requirements shall be eligible to participate in the reverse auction event.

**The following terms and conditions are deemed as accepted by the bidder on participation in the bid event:**

1. TPCODL shall provide the user id and password to the authorized representative of the bidder. *(Authorization Letter in lieu of the same shall be submitted along with the signed and stamped Acceptance Form).*
2. TPCODL will make every effort to make the bid process transparent. However, the award decision by TPCODL would be final and binding on the supplier.
3. The bidder agrees to non-disclosure of trade information regarding the purchase, identity of TPCODL, bid process, bid technology, bid documentation and bid details.
4. The bidder is advised to understand the auto bid process to safeguard themselves against any possibility of non-participation in the auction event.
5. In case of bidding through Internet medium, bidders are further advised to ensure availability of the entire infrastructure as required at their end to participate in the auction event. Inability to bid due to telephone line glitch, internet response issues, software or hardware hangs, power failure or any other reason shall not be the responsibility of TPCODL.
6. In case of intranet medium, TPCODL shall provide the infrastructure to bidders. Further, TPCODL has sole discretion to extend or restart the auction event in case of any glitches in infrastructure observed which has restricted the bidders to submit the bids to ensure fair & transparent competitive bidding. In case of an auction event is restarted, the best bid as already available in the system shall become the start price for the new auction.
7. In case the bidder fails to participate in the auction event due any reason whatsoever, it shall be presumed that the bidder has no further discounts to offer and the initial bid as submitted by the bidder as a part of the tender shall be considered as the bidder's final no regret offer. Any offline price bids received from a bidder in lieu of non-participation in the auction event shall be out-rightly rejected by TPCODL.
8. The bidder shall be prepared with competitive price quotes on the day of the bidding event.
9. The prices as quoted by the bidder during the auction event shall be inclusive of all the applicable taxes, duties and levies and shall be FOR at TPCODL site.
10. The prices submitted by a bidder during the auction event shall be binding on the bidder.
11. No requests for time extension of auction event shall be considered by TPCODL.
12. The original price bids of the bidders shall be reduced on pro-rata basis against each line item based on the final all-inclusive prices offered during conclusion of the auction event for arriving at Contract amount.

Signature &amp; Seal of the Bidder

**TP CENTRAL ODISHA DISTRIBUTION LIMITED**  
(A Tata Power & Odisha Govt. joint venture)

2nd Floor, IDCO Tower, Janpath Bhubaneshwar, Odisha 751022

**ANNEXURE VII**

**Scope of Work (Attached Last Page of Tender Doc.)**

CONFIDENTIAL

**TP CENTRAL ODISHA DISTRIBUTION LIMITED**

(A Tata Power &amp; Odisha Govt. joint venture)

2nd Floor, IDCO Tower, Janpath Bhubaneshwar, Odisha 751022

**ANNEXURE VII-a****Preferential norms for procurement from MSMEs registered in the State of Odisha****1) Tender Fees :**

To participate in the tender, MSMEs registered in the State of Odisha shall pay Rs.1,000/- including GST towards cost of tender paper.

**2) Earnest Money Deposit (EMD)**

EMD shall be exempted for MSME registered in the State of Odisha. However, Bidder shall be barred to participate in the tendering process for a period of 2 years in case it backs out post award of the contract.

**3) Qualification Requirement for Open Tenders**

Qualification Requirement of Financial Turnover for MSME registered in the State of Odisha shall be reduced to 20% of the existing criteria.

For Technical Qualification, instead of relying on the volumes / value of earlier Supplies / Projects, assessment of the Bidder shall be done on the basis of feedback from Customers. Past performance experience at Tata Power and its Group Companies shall supersede feedback from other Customers.

**4) Reservation for MSME**

It shall be mandatory to procure at least 20% of the total volume of the procurement from MSME registered in the State of Odisha (however, it shall not apply where goods/services are not available with the MSME), subject to matching L1 discovered prices and meeting technical specifications including quality requirements.

**5) Performance Bank Guarantees**

Performance Bank Guarantee for MSME registered in the State of Odisha shall be 25% of the value normally prescribed.

<b>TPCODL</b>	<b>TP CENTRAL ODISHA DISTRIBUTION LIMITED</b>	
	<b>WORK INSTRUCTION /OPERATING GUIDELINES</b>	
Doc. Title	<b>GENERAL CONDITIONS OF CONTRACT- COMPOSITE ORDERS</b>	
Rev. No	0	Page 1 of 104

<b>CONTENTS</b>	
<b>CLAUSE NO.</b>	<b>DESCRIPTION</b>
<b>1.0</b>	<b>ORGANIZATIONAL VALUES</b>
<b>2.0</b>	<b>ETHICS</b>
<b>3.0</b>	<b>CONTRACT PARAMETERS</b>
3.1	Issue/ Award of Contract
3.2	Contract Commencement Date
3.3	Contract Completion Date
3.4	Contract Period/Time
3.5	Contract Execution Completion Date
3.6	Contract Execution Period/Time
3.7	Contract Price /Value
3.8	Contract Document
3.9	Contract Language
3.10	Reverse Auction
<b>4.0</b>	<b>SCOPE OF WORK</b>
4.1	Technical Evaluation
4.2	Indemnity
4.3	Display of notice boards at work site
4.4	Disposal of waste at site
4.5	Deployment of workforce
4.6	Damage of Properties
4.7	Issuance of material
4.8	Company's right to use works
4.9	Rights of TPCODL to vary the scope work
<b>5.0</b>	<b>PRICES/RATES/TAXES</b>
5.1	For Supply part of Contract
5.2	For Service part of Contract
5.3	Changes in statutory Tax Structure

Doc. Title	<b>GENERAL CONDITIONS OF CONTRACT - COMPOSITE WORKS</b>	
Rev. No	0	Page 2 of 104

<b>CONTENTS</b>	
<b>CLAUSE NO.</b>	<b>DESCRIPTION</b>
<b>6.0</b>	<b>TERMS OF PAYMENT</b>
6.1	Pre-Requisites for Payment
6.2	Bills & Invoices
6.3	Payment & Statutory Deductions
6.4	Guidelines for Raising Running/Final Bills
6.5	Quantity Variation
6.6	Full and Final Payment
<b>7.0</b>	<b>MODE OF PAYMENT</b>
<b>8.0</b>	<b>SECURITY CUM PERFORMANCE DEPOSIT</b>
<b>9.0</b>	<b>STATUTORY COMPLIANCE</b>
9.1	Compliance to Various Acts
9.2	SA 8000
9.3	Affirmative Action
9.4	Compliance to Labour Laws
9.5	Compliance to C&D Waste Management Rules & Environment (Protection) Amendment Rules
<b>10.0</b>	<b>QUALITY</b>
10.1	Knowledge of Requirements
10.2	Material/Equipment/Works Quality
10.3	Adherence to Rules & Regulations
10.4	Specifications and Standards
<b>11.0</b>	<b>SAFETY</b>
<b>12.0</b>	<b>INSPECTION/PARTICIPATION</b>
12.1	Right to Carry Out Inspection
12.2	Facilitating Inspection
12.3	Third Party Nomination
12.4	Waiver of Inspections
12.5	Incorrect Inspection Call
<b>13.0</b>	<b>MDCC &amp; DELIVERY OF MATERIALS</b>
13.1	Material Dispatch Clearance Certificate

Doc. Title	<b>GENERAL CONDITIONS OF CONTRACT - COMPOSITE WORKS</b>	
Rev. No	0	Page 3 of 104

<b>CONTENTS</b>	
<b>CLAUSE NO.</b>	<b>DESCRIPTION</b>
13.2	Right to Rejection on Receipt
13.3	Consignee
13.4	Submission of Mandatory Documents on delivery
13.5	Dispatch and Delivery Instructions
<b>14.0</b>	<b>GUARANTEE</b>
14.1	Guarantee of Performance
14.2	Guarantee period
14.3	Failure in Guarantee period (GP)
14.4	Cost of repairs on failure in GP
14.5	Guarantee Period for Goods Outsourced
14.6	Latent Defect
14.7	Support beyond the Guarantee Period
<b>15.0</b>	<b>LIQUIDATED DAMAGES</b>
15.1	LD Waiver Request
15.2	Material Recovery
<b>16.0</b>	<b>ASSIGNMENT OR SUBCONTRACTING</b>
<b>17.0</b>	<b>UNLAWFUL ACTIVITIES</b>
<b>18.0</b>	<b>CONFIDENTIALITY</b>
18.1	Documents
18.2	Geographical Data
18.3	Associate's Processes
18.4	Exclusions
18.5	Violation
<b>19</b>	<b>INTELLECTUAL PROPERTY RIGHTS</b>
<b>20</b>	<b>INDEMNITY</b>
<b>21</b>	<b>LIABILITY &amp; LIMITATIONS</b>
21.1	Liability
21.2	Limitation of Liability
<b>22.0</b>	<b>FORCE MAJEURE</b>



Doc. Title	<b>GENERAL CONDITIONS OF CONTRACT - COMPOSITE WORKS</b>	
Rev. No	0	Page 4 of 104

<b>CONTENTS</b>	
<b>CLAUSE NO.</b>	<b>DESCRIPTION</b>
<b>23.0</b>	<b>SUSPENSION OF CONTRACT</b>
23.1	Suspension for Convenience
23.2	Suspension for Breach of Contract Conditions
23.3	Compensation in lieu of Suspension
<b>24.0</b>	<b>TERMINATION OF CONTRACTS</b>
24.1	Termination for default/breach of contract
24.2	Termination for convenience of associate
24.3	Termination for Convenience of TPCODL
<b>25.0</b>	<b>Dispute resolution and Arbitration</b>
25.1	Governing laws and jurisdiction
<b>26.0</b>	<b>ATTRIBUTES OF GCC</b>
26.1	Cancellation
26.2	Severability
26.3	Order of Priority
<b>27.0</b>	<b>INSURANCE</b>
<b>28.0</b>	<b>ERRORS AND OMISSIONS</b>
<b>29.0</b>	<b>TRANSFER OF TITLES</b>
<b>30.0</b>	<b>SUGGESTIONS &amp; FEEDBACK</b>
<b>31.0</b>	<b>CONTACT POINTS</b>
<b>32.0</b>	<b>LIST OF ANNEXURES</b>

Doc. Title	GENERAL CONDITIONS OF CONTRACT - COMPOSITE WORKS	
Rev. No	0	Page 5 of 104

## 1.0 ORGANIZATIONAL VALUES

The Tata Group has always been a value driven organization. These values continue to direct the Group's growth and businesses. The Six core Tata Values underpinning the way we do business are:

**Integrity** - We must conduct our business fairly, with honesty and transparency. Everything we do must stand the test of public scrutiny.

**Understanding** - We must be caring, respectful, compassionate and humanitarian towards our colleagues and customers around the world and always work for the benefit of India.

**Excellence** - We must constantly strive to achieve the highest possible standards in our day to day work and in the quality of goods and services we provide.

**Unity** - We must work cohesively with our colleagues across the group and with our customers and partners around the world to build strong relationships based on tolerance, understanding and mutual co-operation.

**Responsibility** - We must continue to be responsible and sensitive to the countries, communities and environments in which we work, always ensuring that what comes from the people goes back to the people many times over.

**Agility** - We must work in a speedy and responsive manner and be proactive and innovative in our approach.

## 2.0 ETHICS

In our effort towards Excellence and in Management of Business Ethics at TPCODL, an Ethics Management Team is constituted.

The main objective of the Ethics Management Team is to:

1. Record, address and allay the issues and concerns on ethics raised by different stakeholders like employees, consumers, vendors, Associates etc. by initiating immediate corrective actions.
2. Ensure proper communication of the ethics policies and guidelines through prominent displays at all offices of TPCODL and through printed declarations in all concerned documents where external stakeholders are involved.
3. Ensure proper framework of policies as preventive measures against any ethics violation recorded by them.
4. Prepare and submit MIS of all issues and concerns, corrective and preventive actions on monthly basis to the top management for their information.

All members of Team TPCODL, Associates and Stakeholders are requested to register any grievance on ethics violation on Central Control Telephone No. 011-66404040.

## 3.0 CONTRACT PARAMETERS

### 3.1 Issue/Award of Contract

TPCODL awards the contract to the Associate in writing in the form of Purchase order or Rate Contract (RC) hereafter referred as Contract, through in any or all of following modes- physical handover / post / e-mail / web document / fax with all the attachments/enclosures which shall be part of the contract document

Doc. Title	GENERAL CONDITIONS OF CONTRACT - COMPOSITE WORKS	
Rev. No	0	Page 6 of 104

On receipt of the contract, the associate shall return to TPCODL copy of the contract document duly signed by legally authorized representative of associate, within two days of Effective Date of Contract for contracts having contract execution time less than 30 days and within five days for all other contracts.

### **3.2 Contract Commencement Date**

The date of issue/award of contract shall be the Effective Date of Contract or Contract Commencement date.

### **3.3 Contract Completion Date**

The date of expiry of Guarantee Period (detailed in section 12 of this document) shall be deemed as the Contract Completion Date.

### **3.4 Contract Period/Time**

The period from Contract Commencement Date to Contract Completion Date shall be deemed as the Contract Period/Time.

### **3.5 Contract Execution Completion Date**

The stipulated date for completing the execution of all items in the schedule of quantities (Supply, Service and or both as applicable) shall be deemed as the Contract Execution Completion Date.

### **3.6 Contract Execution Period/Time**

The Period from Contract Commencement Date to Contract Execution Completion Date shall be the Contract Execution Period/Time. Timely Completion of Works/Timely Delivery of Materials is the essence of the contract. The period from effective date of contract to the date stipulated for completion of delivery of all items/completion of all the works/services, as per schedule of quantities of the contract is defined as contract execution completion time. The Delivery of Materials /The Completion of Works, as applicable, should be achieved in all respects as per schedules of quantities and all the terms and conditions of the contract, in the contract execution time.

Any revision/amendment in the originally stipulated contract execution time has to be approved by authorized representative of TPCODL.

### **3.7 Contract Price /Value**

The total all inclusive price/value mentioned in the LOI/PO/RC of the contract document is the Contract Price/Value and is based on the quantity, unit rates and prices quoted and awarded and shall be subject to adjustment based on actual quantities supplied/actual measurement of work done and accepted and certified by the authorized representative of the company unless otherwise specified in schedule of quantities or in contract documents.

### **3.8 Contract Document**

The Contract Document shall mean and include but not limited to the following:

- NIT/Tender Enquiry, QR, Instruction to Bidders, Special Condition of Contract (SCC) of tender, GCC, Technical & Commercial Specifications including relevant annexure and attachments).
- Bids & Proposals Received from Associate including relevant annexure/attachments.

Doc. Title	GENERAL CONDITIONS OF CONTRACT - COMPOSITE WORKS	
Rev. No	0	Page 7 of 104

- Letter of Intent (LOI/RC/PO) with agreed deviations from the tender/bid documents.
- All the Inspection and Test reports, Detailed Engineering Drawings.
- Material Dispatch Clearance Certificate (MDCC).
- Minutes of Meeting (MoM)

### 3.9 Contract Language

All documents, instructions, catalogues, brochures, pamphlets, design data, norms and calculations, drawings, operation, maintenance and safety manuals, reports, labels, on deliveries and any other data shall be in English Language.

The Contract documents and all correspondence between the TPCODL, Third Parties associated with the contract, and the Associate shall be in English language.

However, all signboards required indicating "Danger" and/or security at site and otherwise statutory required shall be in English, Hindi, and local languages.

### 3.10 Reverse Auction

TPCODL reserves the right to conduct the reverse auction (instead of public opening of price bids) for the products / services being asked for in the tender. The terms and conditions for such reverse auction events shall be as per the Acceptance Form attached in Annexure J. The bidders along with the tender document shall mandatorily submit a duly signed copy of the Acceptance Form as mentioned in the Annexure J as a token of acceptance for the same.

### 4.0 SCOPE OF WORK

All the activities that are to be undertaken by the Associate to realize the contractual deliverables in completeness form Scope of Work. Following clauses list, but not limited to, major requirements of the scope of work.

The associate shall satisfy himself and undertake fully the technical/commercial requirements of items to be supplied as listed in the Schedule of Quantities together with the tests to be performed /test reports to be furnished before dispatch, arrangement of stage and final inspections during manufacturing as per terms and conditions of contract, technical parameters & delivery terms and conditions including transit insurance to be met in order to fully meet TPCODL's requirements.

Completeness: Any supplies and services which might have not been specifically mentioned in the Contract but are necessary for the scope mentioned in Special Terms & Conditions and/or completeness of the works at the highest possible level, including any royalties, licence fees & compensation to be paid, whether incurred by the associates or by a third party for the work covered in the scope, regardless of when incurred, shall be supplied/provided by the associate without any extra cost and within the time schedule for efficient , smooth and satisfactory operation and maintenance of the works at the highest possible level under Indian conditions (but according to international standards for facility of this type), unless expressly excluded from the scope of supplies and services in this Contract.

TPCODL have the right, during the performance of the Contract, to change the scope and/or technical character of the Project and/or of the supplies and services stipulated in the

Doc. Title	GENERAL CONDITIONS OF CONTRACT - COMPOSITE WORKS	
Rev. No	0	Page 8 of 104

Contract by submitting a request in writing to the Associate. The Associate shall, within fifteen days of receipt of such request from the TPCODL, provide Purchaser with a reasonably detailed estimate of the cost of the change outlined in the request.

In the event, TPCODL requests a change, the Contract price and time shall be adjusted upwards or downwards, as the case may be and shall be mutually agreed to. The associate shall not be entitled to any extension of time unless such changes adversely affect the time schedule.

The Associate shall not proceed with the changes as requested till adjustment of contract price and time schedule where so applicable in terms of or otherwise directed by the TPCODL.

#### 4.1 Technical Evaluation

TPCODL reserves the right to assign scores to different parameters including but not limited to the following while evaluating the bids. TPCODL reserves the right to change the parameters and score without prior information to the associates:

S. No.	Evaluation Parameter	Max. Score
<b>A</b>	<b>Bidders already Registered with TPCODL</b>	<b>100</b>
	<b>Quality of the Products &amp; Services</b>	
	a. <u>For Supply Part:</u> No Material Rejections in last 2 years Deduction of 3 marks for each PO/ RO (for same product category) with major rejections in last 2 years. (Major rejection shall be considered when material is taken back by the vendor for rectification and the quantity of rejected material is more than 10%).	12
<b>A.1.</b>	b. <u>For Service Part:</u> No violation of statutory compliances in last 1 year. Deduction of 2 marks for each instance of violation in last 1 year.	12
	c. <u>Safety</u> Deduction of 2 marks for each instance of safety violation in last 1 year. Deduction of 4 marks for each reported Non-Fatal Accident in last 1 year. In case of any reported fatal accident: <b>ZERO MARKS</b>	16
<b>A.2.</b>	<b>Timely Execution of Contracts</b> Total Achieved Score = {30 – 3 x (Avg. %age LD deductions in last 2 years)}	30
<b>A.3.</b>	<b>Legal Issues with TPCODL</b> Zero instances of Arbitration procedures / Court Cases / PBG forfeitures in last 2 years: 30 marks else 'Zero' marks	30
<b>B</b>	<b>Bidders new to TPCODL</b>	<b>100</b>
	<b>Visits</b> <u>For Supply Part:</u> Factory Visit and Evaluation. <u>For Service Part:</u> Client Site Visit where the bidder is providing similar services.	30
<b>B.1.</b>	The visits as above shall be arranged by the bidder. However all costs towards conveyance, lodging, boarding etc. shall be borne by TPCODL. The score assigned by TPCODL based on the above visits shall be final and binding on the bidder. <b>Safety:</b>	20

Doc. Title	GENERAL CONDITIONS OF CONTRACT - COMPOSITE WORKS	
Rev. No	0	Page 9 of 104

S. No.	Evaluation Parameter	Max. Score
	Score achieved against the BA safety Management System questionnaire.	
<b>B.2.</b>	<p><b>Client Referrals</b> At least 3 nos. Customer References for similar products/ services in last 3 years. All customer references shall be either of the following:</p> <ul style="list-style-type: none"> <li>▪ Govt. Organizations/ PSUs/ Power Distribution Utilities.</li> <li>▪ Private Organizations with an annual turnover of <math>\geq</math> 500 cr.</li> </ul> <p>PO copies or Completion Certificates are admissible. Each reference: 10 marks</p>	30
<b>B.3.</b>	<p><b>Blacklisting Information</b> Not blacklisted by any reputed organization / utility in last 2 years: 20 marks else 'Zero' marks.</p>	20

- Bidder shall be considered as technically qualified if they are able to achieve a technical score of  $>70$  marks on the above parameters. 'A' or 'B'.
- The bidder must have the PF and ESI registration. In case it is not there (provided the bidder is not exempted from the PF and ESI), bidder shall not be evaluated on the above parameters and will be considered as disqualified.

#### 4.2 Indemnity

Associates shall undertake to fully indemnify TPCODL (also referred to as the Company in the GCC) against all kinds of liabilities or damages, of whatsoever nature, including compensation arising from any accident to the person or property of those in Associate's employment or to any other person or properties including those of TPCODL, arising due to reasons attributable to any, act, omission or negligence of the Associate the Associates, for the entire period of contract including period of guarantee.

Within 7 days of award of work, the Associates shall submit Indemnity Bond in the format as per Annexure-E to Order Issuing Authority.

Contract having value more than Rs 2 Cr per Annum, Associates shall submit Indemnity Bond on Rs 100/- Non Judicial Stamp Paper in the format as per Annexure- E to Order Issuing Authority.

#### 4.3 Display of Notice Boards at Work Sites

The Associate shall put up display notice board at each project site where the works are in progress indicating the information given below:

- Name of the Project.
- Estimated Cost of Project.
- Date of Commencement.
- Expected date of completion.
- Name of Associate and his telephone number.
- Name of Engineer-in-Charge and his telephone number.

#### 4.4 Disposal of Waste at Site

Significant quantities of waste are generated during the execution of project and an integrated approach for effective handling, storage, transportation and disposal of the same shall be adopted. This would ensure the minimization of environmental and social impact in order to combat the climate change.

Doc. Title	GENERAL CONDITIONS OF CONTRACT - COMPOSITE WORKS	
Rev. No	0	Page 10 of 104

The associates shall follow the below criteria for disposal of waste at site during the execution of project.

- Associate shall ensure that the detailed project plan include the waste management, segregation of all designated waste material (Recyclable/ Non-Recyclable), collecting, storing, disposing and transferring the same to pre-arranged facility/destination in timely and safe manner as per environmental legislations during the execution of project. The project plan shall also include the innovative construction practice to eliminate or minimize waste, protect surface/ground water, control dust and other emissions to air and control noise during the execution of project. The copy of same shall be given to EIC before the commencement of project.
- The purchase policy of BA shall encourage the procurement of material with recycled and minimum packaging of goods during delivery. Associate shall provide the appropriate means for site to site transportation of materials to avoid damage and litter generation.
- Associate shall educate and inform to its project team about the requirement and responsibilities for waste minimization and disposal in general and provide training of practices that support this. Waste management should be treated like a safety program.
- In the event that area of contaminated or biological hazard is identified, Associate shall ensure that plant, equipment, personnel and any activity associated with the work is carried out in consultation with EIC of TPCODL.
- Associate shall ensure that the residents living near the site are kept informed about proposed working schedule and shall informed timings and duration of any abnormal noise full activity that is likely to happen.
- Associate shall ensure the regular maintenance and monitoring of vehicles and equipment for efficient fuel use so that emissions and noise are within acceptable limits to avoid air pollution.

#### **4.5 Deployment of Work Force**

Associate shall deploy adequate labour, as considered necessary by TPCODL for execution of the contract including Sundays and Holidays whenever required to do so with no extra cost to TPCODL. However, prior permission shall be taken from the site Engineer to carry out the work beyond normal working hours or on Sundays and Holidays. Female employees shall not be deployed beyond normal working hours/days and no child labour shall ever be deployed. Associate shall depute full time qualified and experienced engineers to supervise the work at site. All such staff shall be maintained from commencement to completion of all works to the entire satisfaction of the Engineer-in-Charge. Associate's employees deployed for the works under this contract will not be considered in Company's employment at any time. Associate shall continue to be responsible for all such employees, their safety, all types of statutory compliances related thereto and in any other manner whatsoever. The company will stand indemnified by the Associate in respect of all the above. At the same time Company upon noticing any breach or default on any statutory compliances, may at their sole discretion, decide to act in a manner as deemed fit at the risks and costs of the Associate.

Doc. Title	GENERAL CONDITIONS OF CONTRACT - COMPOSITE WORKS	
Rev. No	0	Page 11 of 104

TPCODL shall have the right to instruct the Associate to change the Sub- Associates or skilled /unskilled workers in case the conduct, the workmanship or speed of the work is not satisfactory.

Associates shall submit duly signed undertaking regarding engagement of competent staff / employee commensurate to the nature of job to Engineer-in-charge in the format attached as Annexure – H.

#### **4.6 Damages to Properties**

The Associates shall take necessary steps to ensure that the equipment and installations of the Company, Third parties, including other utility services like water supply pipelines; open drains telephone cables etc. are not damaged during execution of the works. The Associates shall be responsible for all such damages and shall have to repair/ replace and/or compensate for the entire claims in respect of such damages at its own cost.

#### **4.7 Issuance of Material**

The material issued to the Associate shall be in the custody of the Associates who shall be fully responsible for the same. After completion of the works, the Associates will reconcile the material. Any cost of material which is short or damaged/lost will be deducted from Associate bill/ deposits.

#### **4.8 Company's Right To Use Works**

If Taking Over Certificate is delayed for any reason, for which TPCODL's decision shall be final and binding upon the Associate, the Company shall be entitled to use the works or portion thereof without affecting Associate's responsibility and liability to complete the balance works as per company's directives from time to time, though Associate shall be afforded reasonable opportunity by the company to enable Associates to complete all balance works required for issuance of 'Taking Over Certificate' by the company.

#### **4.9 Rights of TPCODL to vary the scope work**

TPCODL shall have the right, during the performance of the Contract, to change the scope and/or technical character of the Project and/or of the supplies and services stipulated in the Contract by communicating the intent to do so in writing to the Associate. On receipt of such communication the Associate shall, within the time frame specified in the contract shall provide TPCODL with a reasonably detailed estimate of the cost of the change in scope outlined in the TPCODL communication. The change in the Contract price and time shall be revised upwards or downwards, as the case may be, and shall be mutually agreed to. The Associate shall not be entitled to any extension of time unless such changes adversely affect the time schedule.

The Associate shall not proceed with the changes in the scope of work till such time revision of Contract price and time schedule are approved and communicated to the associate by TPCODL.

Any change in the Scope of Work and/or Terms & Conditions of the order shall be intimated by TPCODL through an amendment to the contract. The amendment shall be treated valid only if signed by the authorized signatory of the original contract.

### **5.0 PRICES/ RATES/ TAXES**

#### **5.1 For Supply part of Contract**



Doc. Title	<b>GENERAL CONDITIONS OF CONTRACT - COMPOSITE WORKS</b>	
Rev. No	0	Page 12 of 104

Unless specified elsewhere in the contract document, the prices/rates are inclusive of cost of finished product for which MDCC will be issued by TPCODL, packaging and forwarding charges, freight and transit insurance charges covering loading at Associate's works, transportation to TPCODL store/site & unloading & delivery at TPCODL stores/TPCODL site, cost of documentation including all the relevant test certificates and other supportive documents to be furnished.

The Prices/Rates are inclusive of all taxes, levies, cesses and duties, particularly Goods and Services Tax as applicable. All government levy / taxes shall be paid only when the invoice is submitted according to the relevant act.

The prices/rates shall remain firm till actual completion of entire supply of goods/material/equipment as per contract is achieved and shall remain valid till the completion of the contract.

The prices shall remain unchanged irrespective of TPCODL making changes in quantum in all or any of the schedules of items of contract.

## **5.2 For Service part of Contract**

The Prices and Rates are inclusive of cost of materials supplied as per contract terms and for which MDCC is issued by TPCODL and to the extent required for completion of works, cost of service executed as per schedule of quantities, cost of testing as per contract terms, cost of documentations including all relevant test certificates and other supportive documents to be furnished as per contract terms. The rates shall remain firm till actual completion of contract.

The Prices/Rates are inclusive of all taxes, levies, cesses and duties, particularly Goods and Services Tax as applicable. All government levy / taxes shall be paid only when the invoice is submitted according to the relevant act.

The prices shall remain unchanged irrespective of TPCODL making changes in quantum in all or any of the schedules of items of contract.

## **5.3 Changes in Statutory Tax Structure**

If rate of any or all of the statutory taxes and duties applicable to the contract changes, such changes shall be incorporated by default if the changes occur within the contract execution time and shall be applicable if the contract is executed by the Associate within the Contract Execution Time.

For execution of contracts beyond contract execution time, where the delay is not attributable to TPCODL no upward revision in tax /duties shall be considered irrespective of changes in the statutory tax structure either within the contract execution time or beyond. However, in such cases, benefits due to any downward revisions in statutory tax rates shall be passed on to TPCODL.

## **6.0 TERMS OF PAYMENT**

- A. 5% of the Release Order/ Purchase Order price shall be paid as initial interest free advance on fulfillment of the following by the Associate:
- a) Acceptance of PO/ LOI.
  - b) Submission of advance payment BG of 15% of the Release Order/ Purchase Order price which shall remain valid till the advance is fully adjusted.

Doc. Title	GENERAL CONDITIONS OF CONTRACT - COMPOSITE WORKS	
Rev. No	0	Page 13 of 104

- c) Submission of Contract Performance Bank Guarantee of 5/10% of the RC/ PO price valid till 30 days after taking over of the works.
- B. 10% of the Release Order/ Purchase Order price shall be paid as interest free advance against approval of drawings under Category-1 of major drawings, Quality Plans, Pert Chart, Field Quality Plan, posting of Project Manager and commencement of the first mile stone of the work mutually agreed including C-3 Form, and submission of a true copy of 'Erection All Risk Insurance Policy' taken for the awarded jobs. The drawing list shall be mutually agreed at the time of award of work.
- C. 50% on account payment of the total of item wise cost of material Release Order/ Purchase Order shall be paid against receipt of material at site in good condition and certification by TPCODL along with bills complete in all respects viz. MDCCs etc.
- D. 20% on account payment of the actual executed value shall be paid against mechanical completion of erection on prorata basis against monthly bills and 70% on account of the actual executed value shall be paid against the service line item including composite line item. In case this milestone is not completed beyond 120 days for reasons attributable to TPCODL, the payment corresponding to supply part shall be released subject to submission of BG of equivalent amount by the BA valid for a period of further 12 months. If required, it shall be extended by the BA on request of TPCODL.
- E. 15% payment of the actual executed Release Order/ Purchase Order shall be paid after completion of acceptance test and Taking Over of the complete systems specified in the enquiry, including clearance of Electrical Inspection, compliance of final punch point and after reconciliation & adjustment of payments, if any, towards Quantities of materials issued from purchaser's stock and consumed by the contractor for expeditious completion of the job. In case this milestone is not completed beyond 120 days beyond schedule for reasons attributable to TPCODL, the payment corresponding to supply part shall be released subject to submission of BG of equivalent amount by the BA valid for a period of further 12 months. If required, it shall be extended by the BA on request of TPCODL.

The Contractor shall submit all Operation & Maintenance manuals and "As Built Drawings" etc. and shall also submit Equipment Warranty Bank Guarantee (EWBG) equivalent to 5/10% of actual executed contract price before the release of this last payment and return of CPBG. The validity of EWBG shall be for a period of 15 months from the date of taking over of the works or specified guarantee period in drawing/tender/technical specification documents etc. whichever is later. The associate shall also submit 'No Demand Certificate' at the time of receipt of full and final payment.

### 6.1 Pre-Requisites for Payment

- Associate should have completed execution of that part of contract, for which payment is sought, to the satisfaction of TPCODL's Engineer-in-Charge responsible for the contract and obtained certification for execution of the work.
- Associate has undertaken joint measurement of the work executed along with TPCODL's Engineer-in-charge

Doc. Title	GENERAL CONDITIONS OF CONTRACT - COMPOSITE WORKS	
Rev. No	0	Page 14 of 104

- Associate's bills/invoices submitted have been certified by Engineer-In-Charge.

## 6.2 Bills & Invoices

Unless specified otherwise in the special conditions of contract, Associate shall raise not more than one invoice/contract per month for the services rendered in the prescribed Tax Format and the invoice shall be submitted within 15 days of the following month at Bill Inward Receipt Desk (BIRD) located at Civil Lines III Office, TPCODL.

All Bills shall be supported by joint measurement of work done, quality test report and a copy of wage sheet, if applicable (showing proof of having disbursed wages as per applicable law) and a copy of statement substantiating that statutory payments having been affected.

Bills/ invoices shall mention Associate's 'Sales, Service, WCT Tax Registration Number, PAN number as applicable.

Final bill submission after completion of project or execution of job must be within 30 days from the actual date of completion/execution of work awarded.

## 6.3 Payment & Statutory Deductions

Payment shall be released within 30 days from the submission of the bills. The associate shall submit "No Demand Certificate" in the format as per Annexure-D at the time of receipt of full and final payment. In case any non-compliance to contract conditions comes to TPCODL's notice, TPCODL will be entitled to deduct 30% of estimated wages plus 20% of wages as TPCODL's overheads. Associates would be obliged to provide the copy of monthly wage sheet in any case, failing which no payment shall be made. TPCODL at their sole discretion may deposit the PF etc. with statutory authorities. TPCODL will deduct the amounts of TDS as per statutory requirement under the income tax act and the DVAT Act and certificates (wherever applicable) will be issued to associate accordingly.

In case of non-submission of PAN No TDS @ 20% shall be deducted from all payable amounts for which no TDS certificate shall be issued. TDS once deducted as above shall not be revised in any condition.

### 6.3.1 Statutory Deductions

TPCODL will deduct the amounts of TDS, TCS as per statutory requirement under the income tax act, the Goods and Services tax act, BOCW Act, or any other applicable tax act and certificates (wherever applicable) will be issued to associate accordingly. For consumption of TPCODL's Water and Electricity by Associate for execution of Contract, Associate shall pay 0.5% & 1.0% respectively of contract value and it shall be deducted from the running bills. The Engineer-in-Charge as stated in the Order shall be responsible for certification of the work executed and the bills. Bills (including original) shall be submitted in triplicate at Bill Inward Receipt Desk (BIRD) located at Civil lines-III, Near Vidhan Sabha, TPCODL.

## 6.4 Guidelines for Raising Running/Final Bills

Contract Value Up to 5 Lakhs	One Final Bill
Contract Value More than 5 lakhs	Monthly Running Bill & One Final Bill

All Bills shall be processed only when all bank Guarantees are in place and before payments of Final Bill Associate have to furnish NDC.

Doc. Title	<b>GENERAL CONDITIONS OF CONTRACT - COMPOSITE WORKS</b>	
Rev. No	0	Page 15 of 104

## **6.5 Quantity Variation**

Payment will be made on the basis of actual quantity of supplies/actual measurement of works accepted by TPCODL and not on the basis of contract quantity.

## **6.6 Full and Final Payment**

Full & Final Payment in all contracts shall be made subject to the associate submitting "No Demand Certificate" in the format as per Annexure-D.

## **7.0 MODE OF PAYMENT**

Payment shall be made through RTGS mode for which Business Associated shall submit the details of Bank Account and other details as per annexure K. Further, for any payments made, TPCODL is not responsible for any consequences/disputes Associate have among the owners channel partners, sub-Associates and all such dispute/concerns shall be settled solely by the Associate.

The quantities of items indicated are estimated and preliminary. However, payments shall be made on the basis of actual quantity of work carried out and measured jointly by the Company and the Associate. Associates shall be responsible to organize joint measurements of works with TPCODL Engineer-in-Charge before raising any bill of work done. In the event Associate fails to do so, TPCODL at their sole discretion, may take measurements of work done and proceed as deemed fit and in such an event Associate's right to lodge any subsequent claim shall stand forfeited.

## **8.0 SECURITY CUM PERFORMANCE DEPOSIT**

Associates shall submit within 15 days from the effective date of issue of PO/RC, Security cum Performance Guarantee (SPBG) in the format as per Annexure B of this document from banks acceptable to TPCODL for:

(a) 5% of the PO value if purchase order value is more than Rs 5 Crores.

(b) 10% of the PO value if purchase order value is less than Rs 5 Crores.

This shall remain valid till the end of the Guarantee Period of contract, plus one month.

(c) 5% of the RC value in case of Rate Contract. This shall remain valid till the Guarantee period plus one month.

- For PO/RC values less than Rs. 5 lacs, Associate may request for deduction of amount equivalent to SPBG value from their first invoice. Such amount shall be withheld by TPCODL while processing the invoice and shall be released after completion of Guarantee Period plus one month.
- For PO/RC values less than Rs. 3 lacs, the clause (8.0) for Security cum Performance Bank Guarantee (SPBG) shall not be applicable..
- In case of RC (Rate Contract) after the expiry of RC validity, Associate shall have to submit SPBG. However, the Associate has the option to re-submit the SPBG as per actual RO (Release Order) value issued against the RC, valid for Guarantee Period plus one month. The Guarantee Period shall be considered as per the last RO issued against the said RC. The original SPBG as submitted against the RC shall be released on submission of the new SPBG to TPCODL. Alternatively, Associate may extend the

Doc. Title	<b>GENERAL CONDITIONS OF CONTRACT - COMPOSITE WORKS</b>	
Rev. No	0	Page 16 of 104

validity of original SPBG only till the requisite period, i.e. Guarantee Period plus one month.

## **9.0 STATUTORY COMPLIANCE**

### **9.1 Compliance to Various Acts**

Associate should ensure adherence to all applicable laws, rules and regulation applicable under this contract from time to time. In case of violation any risk, costs etc shall be in associates account and keep TPCODL indemnified always till completion of contracts.

### **9.2 SA 8000**

Further being TPCODL is SA 8000 complied and expects its Associates to follow guidelines of SA8000: 2014 on the following aspects

1. Child Labour
2. Forced or Compulsory Labour
3. Health & Safety
4. Freedom of Association & Right to Collective Bargaining
5. Discrimination
6. Disciplinary Practices
7. Working Hours
8. Remuneration
9. Management System

### **9.3 Affirmative Action**

TPCODL appreciate and welcome the engagement/employment of persons from SC/ST community or any other deprived section of society by their business associates.

### **Relaxation in Contract Clauses under Affirmative Action for SC/ ST Business Associates\*\***

TPCODL believes that inclusive growth is the key to sustainable development, and to promote the same Policy on Affirmative Action for Scheduled Caste & Scheduled Tribe Communities has been adopted across the company.

Under the same pre-text, and to promote entrepreneurship among SC/ST community TPCODL has taken initiative by proposing relaxations in contract clauses as per below:

<b>S. No.</b>	<b>Initiative</b>	<b>for SC/ ST BA's</b>	<b>Guideline Document</b>
1	Tender Fees	100% waiver for SC/ST community	All Open Tenders
2	Earnest Money Deposit	50 % relaxation of estimated EMD value	All limited and Open Tenders
3	Performance Bank Guarantee	25% relaxation in PBG for order value above 50 lacs else 50% relaxation	All limited and Open tenders
4	Turnover	25% relaxation in company turnover under qualifying requirement criteria	All Open Tenders

Doc. Title	GENERAL CONDITIONS OF CONTRACT - COMPOSITE WORKS	
Rev. No	0	Page 17 of 104

**\*\*Classification of BAs under SC/ST shall be governed under following guidelines:**

- Proprietorship/ Single Ownership Firm: Proprietor of the firm should be from SC/ST community. Governing document shall be duly audited balance Sheet for the last FY bearing the name of proprietor.
- Partnership Firm: Only such firms shall qualify which have SC/ST partners holding equal to or more than 50% of the total ownership pattern of the firm. Governing document shall be Partnership Deed and audited balance sheet/ ITR for last FY.
- Private limited company: Only such firms shall qualify which have SC/ST directors holding equal to or more than 50% of the total ownership pattern of the firm. Governing document shall be Memorandum of Understanding (MoU) and/or Article of Association (AoA).

*## Certification from SC/ST commission shall be required for deciding upon SC/ST status of a person.*

**9.4 Compliance to Labour Laws**

Bidder needs to ensure compliance to applicable labour laws including timely disbursement of wages. In case wages are not disbursed as per the stipulated timelines, then TPCODL shall pay the wages to BA employees on behalf of BA. Apart from deducting the amount of wages paid, TPCODL shall deduct an additional service charge equivalent to 25% of the wages paid from the payment due to BA.

**9.5 Compliance to Construction and Demolition Waste Management Rules & Environment (Protection) Amendment Rules**

BA is liable to follow the Construction and Demolition Waste Management Rules- 2016, Environment (Protection) Amendment Rules- 2018 and Guidelines on dust mitigation measures in handling construction material and C&D wastes issued by CPCB.

Following are some main points of above Rules/Guidelines for Construction work, cable laying jobs etc.

1. Barricading to be provided at site to cover complete area.
2. Construction material and waste should be inside the closed area made by using barricading.
3. Water sprinkling/fine spray from nozzles to be done to suppress the dust.
4. The board of Dust mitigation measures shall be displayed at site for public viewing with required details.
5. Loose sand or soil and construction material that causes dust shall be covered.
6. Transport material that are easily wind borne need to be covered by a sheet made of either jute, tarpaulin, plastic or any other effective material.
7. All areas for storing C&D waste/construction material to be demarcated and preferably barricaded particularly those materials that have potential to be dust borne.
8. Grinding and cutting of building materials in open area shall be prohibited.
9. Construction material and waste should be stored only within earmarked area and road side storage of construction material and waste shall be prohibited.
10. No uncovered vehicles carrying construction material and waste shall be permitted.
11. Construction and demolition waste processing and disposal site shall be identified and required dust mitigation measures to be notified at the site.

Doc. Title	GENERAL CONDITIONS OF CONTRACT - COMPOSITE WORKS	
Rev. No	0	Page 18 of 104

## **10.0 QUALITY**

### **10.1 Knowledge of Requirements**

The Associate shall be deemed to have carefully examined and to have knowledge of the equipment, the general and other conditions, specifications, schedules, drawings, etc. forming part of the Contract and also to have satisfied himself as to the nature and character of the work to be executed and the type of the equipment and duties required including wherever necessary of the site conditions and relevant matters and details. Any information thus procured or otherwise obtained from TPCODL/Consultants shall not in any way relieve the Associate from his responsibility and executing the works in accordance with the terms of contract.

### **10.2 Material/Equipment/Works Quality**

The items / works under the scope of the Associate shall be of the best quality and workmanship according to the latest engineering practice and shall be manufactured from materials of best quality considering strength and durability for their best performance and, in any case, in accordance with the specifications set forth in this Contract. All material shall be new. Substitution of specified material or variation from the process of fabrication/construction/manufacture may be permitted but only with the prior written approval of the TPCODL.

### **10.3 Adherence to Rules & Regulations**

The Associate shall procure and/or fabricate/erect all materials and equipment in accordance with all requirements of Central and State enactment, rules and regulations governing such work in India and at site. This shall not be construed as relieving the Associate from complying with any requirement of TPCODL as enumerated in the Contract which may be more rigid than and not contrary to the above mentioned rules, nor providing such construction as may be required by the above mentioned rules and regulations. In case of variance of the Technical Specification from the laws, ordinance, rules and regulations governing the work, the Associate shall immediately notify the same to the TPCODL. It is the sole responsibility of the Associate, however, to determine that such variance exists. Wherever required by rules and regulations, the Associate shall also obtain the statutory authorities' approval for the plant, machinery and equipment to be supplied by the Associate.

### **10.4 Specifications and Standards**

The Associate shall follow all codes and standards referred in the Contract Document. Codes and standards of other may be followed by the Associate with the prior written approval of TPCODL, provided materials, supplies and equipment according to the standard are equal to or better than the corresponding standards specified in the Contract.

Brand names mentioned in the Contract documents are for the purpose of establishing the type and quality of products to be used. The Associate shall not change the brand name and qualities of the bought out items without the prior written approval of the TPCODL. All such products and equipment shall be used or installed in strict accordance with original manufacturer's recommendations, unless otherwise directed by the TPCODL. In any

Doc. Title	GENERAL CONDITIONS OF CONTRACT - COMPOSITE WORKS	
Rev. No	0	Page 19 of 104

circumstances the codes, specimen and standards prescribed by any government agency should not be violated.

## **11.0 SAFETY**

All Associates shall strictly abide by the guidelines provided in TPCODL's Contractor Safety Management System (CSMS) as applicable at all stages during the contract period. Associate shall execute the contracts ensuring the following in and as order of priority:

- Safety of Human Beings.
- Safety of equipment/Assets.
- Timely Completion of Contract.

Safety related requirements as mentioned in our Contractor Safety Management System is attached as annexure L and is an integral part of this GCC.

## **12.0 INSPECTION/PARTICIPATION**

### **12.1 Right to Carry Out Inspection**

TPCODL reserves the right to send its representatives for inspection or participation at various stages of contract execution listed below, applicable as per contract construction.

- During basic design and detail engineering of material/ Equipment carried out by Associate /Outsourced Agencies.
- During manufacturing stages of the product at Associate's/Associate's Outsourced Agency's Plant/Facility.
- During Pre-dispatch Inspection and Testing of finished/manufactured product at Associate's/Associate's outsourced Agency's Plant/Facility.
- During Installation & Commissioning Activities/Stages.
- Prior to Clearing of the completed installation for commissioning.
- Any other stage as find appropriate by TPCODL during contract execution time.

All inspections and participations shall be carried out within maximum of two weeks of TPCODL giving written intimation to the Associate or receiving appropriate advance written inspection call from the Associate, unless otherwise specified elsewhere in the contract document.

### **12.2 Facilitating Inspection**

The Associate shall provide all opportunities and information to TPCODL's engineers to get acquainted with the technical know-how and the methods and practices adopted by the Associate in basic and detail engineering. The Associate shall provide documents, drawings, calculations etc. as may be required by TPCODL's Engineers.

The Associate shall provide free of charge office accommodation, office facilities, secretarial services, communication facilities, general and drawing office stationary, etc. as may be reasonably required by the TPCODL's engineers. Similarly, facilities shall also be provided by Associate's outsource agencies/partners/authorized dealers (collectively termed as sub-associates) if such basic and detail engineering activities are carried out in the design offices of sub-Associates.



Doc. Title	<b>GENERAL CONDITIONS OF CONTRACT - COMPOSITE WORKS</b>	
Rev. No	0	Page 20 of 104

The Associate shall be responsible for the safety of employees of TPCODL/Third Party Agency when they are at the Associate's /Associate's outsource agency's plant or facility for carrying out/witnessing inspection/testing. All statutory safety precautions as applicable shall be followed by the Associate during Inspection Testing. If TPCODL inspectors are not satisfied with the safety arrangements at the plant, TPCODL have the right to call off inspection till such time corrective action is taken by the Associate.

Before raising the call for pre-dispatch final inspection and testing, the Associate shall conduct all the tests—type tests, routine tests etc-as specified in the contract document and submit copies of the test certificates to TPCODL along with the inspection call, for scrutiny of TPCODL.

The Associate and TPCODL shall jointly document all the observations, comments and action points after completion of inspection and it shall be binding on the Associate to provide compliance on all the points requiring compliance and furnish the compliance report to the designated authority of TPCODL for receiving clearance for dispatch of materials.

### **12.3 Third Party Nomination**

TPCODL also may nominate a third party for the purpose of carrying out the inspection and such an agency shall be entitled to all the rights and privileges of TPCODL as far as conducting the inspection.

### **12.4 Waiver of Inspections**

TPCODL on its own discretion shall chose to waive off any inspection and ask the Associate to submit all the test reports as applicable as per contract specifications, related to inspection and testing of the goods ordered for scrutiny and clearance for dispatch.

### **12.5 Incorrect Inspection Call**

In case it is observed that the material offered for inspection is not ready at the time of TPCODL inspection visit rendering it as futile, all costs towards such inspection shall be recovered from the BA. Taxes as applicable on such recoveries shall be borne by the BA.

## **13.0 MDCC & DELIVERY OF MATERIALS**

### **13.1 Material Dispatch Clearance Certificate**

Associate shall deliver material/goods/equipment against Supply Contracts or Supply Part of Composite/Service Contracts only after receiving Material Dispatch Clearance Certificate (hereafter termed as MDCC) issued by designated authority of TPCODL. Material delivered at TPCODL stores or at project site without a valid MDCC issued by the designated official of TPCODL shall be rejected. MDCC shall be issued to associate furnishing compliance report on the action points documented during pre-dispatch inspection and testing at Associate's/ Sub-Associate's plant/ facility. In case Pre-dispatch inspection is waived at the discretion of TPCODL, then, MDCC shall be issued on receiving all the test reports-routine& type-from the Associate and finding them in order.

The associate shall include and provide for securely protecting and packing the materials so as to avoid loss or damage during handling and transport by air, sea, rail and road or any other means.

All such packing shall allow to the extent possible for easy removal and checking at Site. The associate shall take special precautions to prevent rusting of steel and iron parts during

Doc. Title	GENERAL CONDITIONS OF CONTRACT - COMPOSITE WORKS	
Rev. No	0	Page 21 of 104

transit by sea. Gas seals or other materials shall be utilised by the associate for protection against moisture during transit of all Plant and Equipment.

Each Equipment or parts of Equipment shall be tagged with reference to the assembly drawings and corresponding part numbers. Each bale or package shall contain a packing note quoting specifically the name of the associate, item description, quantity, item / package identification.

All packing cases, containers, packing and other similar materials shall be new and supplied free by the associate and it shall not be required to be returned to the associate.

Notwithstanding anything stated in this clause, the associate shall be entirely responsible for loss, damage or depreciation or deterioration to the materials and supplies due to faulty and/or insecure packing or otherwise during transportation to the Site until otherwise provided herein.

In case of the consignments dispatched by road, the associate shall ensure that it or its sub-contractors:

- i) Identify and obtain the correct type of trucks/trailers, keeping in view the nature of consignments to be dispatched.
- ii) Take such actions as may be necessary to avoid all possible chances of damages during transit and to ensure that all packages are firmly secured.

Timelines for inspection and MDCC is as below:

S. No.	Inspection	MDCC issuance time including inspection time (max.)
1	Outside Bhubaneswar	12 days
2	Within Bhubaneswar	5 days
3	Waiver*	3 working days

\* Associate is expected to raise the inspection call assuming that Inspection shall be carried out by TPCODL. The decision for waiver of inspection shall be on sole discretion of TPCODL.

### 13.2 Right to Rejection on Receipt

Goods/Material/Equipment delivered in condition physically damaged & incomplete as a product ordered, or not packed and transported as per the terms and conditions of the contract is liable to be rejected. Such item shall be lifted back by Associates within 15 days from receipt of rejection note from TPCODL and have to supply back the material within next 30 days or within the timeframe mutually decided by Associate and TPCODL.

If delivery of the material is beyond the agreed time, Liquidated damage clause, mentioned in this GCC separately shall be applicable; but the period for levy of LD shall be considered as per the original delivery schedule and not from the agreed timelines for material rectification.

### 13.3 Consignee

Unless otherwise specified in the Contract Document, Materials/Goods/Equipment shall be consigned to "Stores-In-Charge", TPCODL Bhubaneswar.

### 13.4 Submission of mandatory documents on Delivery

Doc. Title	GENERAL CONDITIONS OF CONTRACT - COMPOSITE WORKS	
Rev. No	0	Page 22 of 104

Following documents shall be mandatorily submitted by BA along with supply of material to TPCODL stores/site:

S. No.	Documents	Requisite
1	Invoice copy in original	With all consignments
2	LR copy	Wherever required
3	Packing list	With all consignments
4	MDCC	With all consignments
5	Purchase order / Release order	Signed copy
6	Test certificates	With all consignments
7	Inspection/JVR report	In case pre-dispatch inspection is conducted
8	Device data in CD as per template for metering items	Wherever applicable

### 13.5 Dispatch and Delivery Instructions

S. No.	Instructions
1	Purchase order/ Release order no. shall be mentioned on invoice and on material
2	TPCODL material code and material description shall be mentioned in invoice and on material.
3	"Property of TPCODL" shall be embossed on material.
4	The material shall be properly sealed and packed in standard packing as per purchase order terms & conditions.
5	The weight and quantity of material shall be mentioned wherever applicable
6	The material supplied shall be co-related with the packing list.
7	The name plate detail on equipment shall include Material code, Material description, specification detail of material [as applicable], Serial No. Year of manufacturing, PO/RO no. and date, "PROPERTY OF TPCODL, Bhubaneswar", Guarantee period and Associate's name.
8	In case of manual unloading, supplier / transporter shall deploy sufficient Labour for unloading the material at TPCODL central store. For heavy item(s), crane will be provided by TPCODL [unloading cost will be recovered from the associate].
9	The driver should have valid License and one helper in truck. All the documents of truck like registration papers, PUC etc should be available in Truck.
10	BA representative should accompany the material and get it unloaded / stacked in his presence wherever possible.

### 14.0 GUARANTEE

#### 14.1 Guarantee of Performance

Associates shall stand guarantee that the equipment and material supplied/service or work rendered under the contract is free from design, manufacturing, material, construction, erection & installation and workmanship & quality defects and is capable of its due, rated and intended quality performance, as an integrated product delivered under the contract. for a specific period termed as Guarantee Period(as elaborated elsewhere in this clause) The

Doc. Title	GENERAL CONDITIONS OF CONTRACT - COMPOSITE WORKS	
Rev. No	0	Page 23 of 104

Associate should also guarantee that the equipment/material is new and unused except for the usage required for the tests and checks required as part of quality assurance.

#### **14.2 Guarantee Period**

The Guarantee Period will be equipment/service/work specific and shall be as specified in the Standard Specifications of TPCODL for the equipment/material/service/work and where standard specifications are not part of contract documents or guarantee period is not specified in the standard specifications,, the guarantee period shall be as per the Special Terms and Conditions of the Contract. In case of no mention of the guarantee period in standard specifications or SCC Guarantee Period will be 15 Months from the Date of Commissioning or 24 months from the date of delivery of final lot of supplies made, whichever is earlier.

#### **14.3 Failure in Guarantee Period (GP)**

If the equipment and material supplied/service or work rendered under the contract fails to perform its due, rated & intended quality performance, during the Guarantee period, the associate is liable to undertake repair/rectify/replace the equipment and material supplied/service or work rendered under the contract within time frame specified in the SCC or elsewhere in the contract documents at associate's cost to make the equipment and material supplied/service or work rendered under the contract of performing its due, rated and intended quality performance. If Associate fails to repair/rectify/replace the equipment or material supplied/service or work rendered under the contract, failed in Guarantee Period, TPCODL will be at liberty to get the same done at Associate's risks and costs and recover all such expenses plus the TPCODL's own charges (@ 20% of expenses incurred), from the Associate or from the "Security cum Performance Deposit" as the case may be.

If during the Warranty/ Guarantee period some parts of the supplies are replaced owing to the defects/ damages under the Warranty, the Warranty period for such replaced parts shall be until the expiry of twelve months from the date of such replacement or renewal or until the end of original Guarantee period, whichever is later.

Any repairs during the Guarantee Period shall be carried out by the Associate within 30 days of reporting the issue to Associate by TPCODL. However, if replacement of the Equipment is required, Associate shall notify the same to TPCODL within 7 days of reporting the issue by TPCODL. Thereafter, the total time for supply of new equipment/ material shall be equal to the original delivery period of that equipment/ material as specified in the Contract. In case the Associate is not able to rectify/ replace the faulty equipment/ material within the stipulated timelines as mentioned above, penalty shall be levied as per the Liquidated Damages clause mentioned in this document. The penalty amount shall be recovered from the payment due to the vendor or by encashment of the SPBG as the case may be.

#### **14.4 Cost of repairs on failure in GP**

The cost of repairs/rectification /replacement, apart from the actual cost of repairs/rectification/replacement is also inclusive of all associate costs of required transportation, site inspection /mobilization/dismantling and re-installation costs as applicable, to be borne by the Associate. The Associate has to ensure that the interruption in the usage of intended purpose of the equipment is minimized to the maximum extent In lieu of the time taken for repairs/rectification/replacement.

Doc. Title	GENERAL CONDITIONS OF CONTRACT - COMPOSITE WORKS	
Rev. No	0	Page 24 of 104

#### **14.5 Guarantee period for Goods Outsourced**

If the Associate outsources partly equipment/materials/services from third party as mutually agreed upon at the pre award stage of contract, TPCODL shall have the benefit of any additional guarantee period if provided by the third party for the part supplied/executed by them.

#### **14.6 Latent Defect**

Hidden defects in manufacturing or design of the product supplied and which could not be identified by the tests conducted but later manifested during operation of the equipment are termed as latent defects. Associates shall further be responsible for 'free replacement' for another period of THREE years from the end of the guarantee period for any 'Latent Defects' if noticed and reported by the Company.

#### **14.7 Support beyond the Guarantee Period**

The Associate shall ensure availability of spares and necessary support for a period of at least 10 years post completion of guarantee period of equipment supplied against the contract.

#### **15.0 LIQUIDATED DAMAGES**

Liquidated damages @1% of the total executed contract value per week or part thereof, for the period of delay in integrated completion, subject to maximum 10% of the value of the contract shall become leviable without prejudice to other rights of the TPCODL. This amount shall be recoverable from any amount due or becoming due to the Business Associates under this or any other contract. In specific cases, TPCODL reserves the right to apply LD only on the unexecuted portion of the supply and works for standalone use, provided full quantity is executed within a maximum 30% additional time. Deduction of LD shall be on landed cost i.e contract value inclusive of taxes and in pursuant statutory compliance GST would be applicable at the stipulated rate and the same shall be borne by Business Associate. In case of LD deduction, a GST invoice shall be issued by TPCODL as a proof of deduction/ recovery.

#### **15.1 LD Waiver Request**

Any request of LD waiver shall be submitted within thirty (30) days of deducting LD. Request submitted beyond the timeline shall not be entertained.

#### **15.2 Material Recovery**

In case of any recoveries for materials or services (for material free issued by TPCODL and not reconciled by BA or for services claimed and paid in excess at the time of running bills), the total cost which shall be recovered from the BA, shall be the gross amount of material or services (i.e. including taxes) plus applicable taxes as prevailing at the time of such recoveries.

#### **16.0 ASSIGNMENT OR SUBCONTRACTING**

Associates shall not assign/subcontract/outsource the schedule of activities of contract TPCODL enters with the associate, in part or full, without TPCODL's prior written approval.

Doc. Title	<b>GENERAL CONDITIONS OF CONTRACT - COMPOSITE WORKS</b>	
Rev. No	0	Page 25 of 104

However outsourcing of materials/equipment/services by Associate to make the integrated product for which TPCODL's has placed the contract with the associate from suppliers, makes and agencies which have been mutually agreed upon during contract pre-award stage is permitted subject to following conditions.

In such cases where outsourcing is done by the Associate

- Shall ensure that outsourced suppliers comply with the technical and financial qualification requirements specified by TPCODL in the contract document
- Shall furnish all particulars about the proposed outsourcing agencies and the details of the goods/services/work outsourced to the Associate while seeking approval of TPCODL for inclusion for outsourcing. The Associate shall give approval or shall refuse approval in writing within thirty (30) days of receipt of such request. However the Associate shall not be entitled for any additional contract execution time whatsoever in lieu of the process for approval for outsourcing agencies, and shall be held responsible for any delay in the project execution time.
- Shall remain jointly and severally liable for any action, deficiency, and/or negligence on the part of his outsourcing agencies. The approval extended by the Associate to outsourcing agencies recommended by the Associate shall not discharge the later from his Contract obligations.

Shall submit to the Associate unpriced copies of purchase orders with technical specifications included in the orders, placed on outsourcing agencies as soon as the respective orders have been placed by the Associate.

#### **17.0 UNLAWFUL ACTIVITIES**

The Associate shall have to ensure that none of its employees are engaged in any unlawful activities (whether covered under the scope of the present GCC or not) subversive of the TPCODL's interest failing which appropriate action (legal or otherwise) may be taken against the Associate by the TPCODL, in accordance with the terms of the present GCC.

#### **18.0 CONFIDENTIALITY**

Associate and its employees or representatives thereof shall strictly maintain the confidentiality of various information they come across while executing the contract as detailed below.

##### **18.1 Documents**

All maps, plans, drawings, specifications, schemes and other documents or information related to the Contract/Project and the subject matter contained therein and all other information given to the Associate by the TPCODL in connection with the performance of the contract shall be held confidential by the Associate and shall remain the property of the TPCODL and shall not be used or disclosed to third parties by the Associate for any purpose other than for which they have been supplied or prepared. The Associate may disclose to third parties, upon execution of confidentiality agreements, such part of the drawings, specifications or information if such disclosure is necessary for the performance of the Work provided such third parties agree in writing to keep such information confidential to the same extent and degree as provided herein, for the benefit of the TPCODL.

##### **18.2 Geographical Data**

Doc. Title	<b>GENERAL CONDITIONS OF CONTRACT - COMPOSITE WORKS</b>	
Rev. No	0	Page 26 of 104

Maps, layouts and photographs of the unit/plant including its surrounding regions showing vital installation for national security of country or those of TPCODL shall not be published or disclosed to the third parties or taken out of the country without prior written approval of the TPCODL and upon execution of confidentiality agreements satisfactory to the TPCODL with such third parties prior to disclosure.

### **18.3 Associate's Processes**

Title to secret processes if any developed by the Associate on an exclusive basis and employed in the design of the equipment shall remain with the Associate. TPCODL shall hold in confidence such processes and shall not disclose such processes to the third parties without prior approval of the Associate and execution by such third parties of secrecy agreements satisfactory to the Associate prior to disclosure. Upon completion of contract, such processes shall become the property of the TPCODL. Title to technical specifications, drawings, flow sheets, norms, calculations, diagrams, interpretations of test results, schematics, layouts and such other information, which the Associate has supplied to the TPCODL under the Contract shall be passed on to the TPCODL. The TPCODL shall have the right to use these for construction, erection, start-up, Trial Run, operation, maintenance, modifications and/or expansion of the works including for the manufacture of spare parts.

### **18.4 Exclusions**

The provision of Clauses 16.1 to 16.3 shall not apply to information:

- Which at the time of disclosure are in the public domain which later on become part of public domain through no fault of the party concerned, or
- Which were in the possession of the party concerned prior to disclosure to him by the other party, or
- Which were received by the party concerned after the time of disclosure without restriction on disclosure or use, from a third party who did not acquire such information directly or indirectly from the other party or has no obligation of confidentiality for such information.

### **18.5 Violation**

In case of violation of this clause, the Associate is liable to pay compensation and damages as may be determined by the competent authority of TPCODL.

## **19.0 INTELLECTUAL PROPERTY RIGHTS**

If, in the course of performance of its functions and duties as envisaged by the scope of the present GCC, the Associate acquires or develops, any unique knowledge or information which would be covered, or, is likely to be covered within the definition of a trademark, copyright, patent, business secret, geographical indication or any other form of intellectual property right, it shall be obliged, under the terms of this present GCC, to share such knowledge or information with the TPCODL. All rights, with respect to, or arising from such intellectual property, as afore mentioned, shall solely vest in TPCODL.

Moreover, the Associate undertakes not to breach any intellectual property right vesting in a third party/parties, whether by breach of statutory provision, passing off, or otherwise. In the event of any such breach, the Associate shall be wholly liable to compensate, indemnify or make good any loss suffered by such third party/parties, or any compensation/damages

Doc. Title	GENERAL CONDITIONS OF CONTRACT - COMPOSITE WORKS	
Rev. No	0	Page 27 of 104

arising from any legal proceeding/s, or otherwise. No liability of TPCODL shall arise in this respect, and any costs, damages, expenses, compensation payable by TPCODL in this regard to a third party/parties, arising from a legal proceeding/s or otherwise, shall be recoverable from the Associate.

## 20.0 INDEMNITY

The Associate shall at all times indemnify, keep indemnified and hold harmless the TPCODL and its officers, directors, employees, affiliates, agents, successors and assigns against all actions, claims, demands, costs, charges and expenses arising from or incurred by reason of any infringement of patent, trade mark, registered design, copy rights and/or industrial property rights by manufacture, sale or use of the equipment supplied by the Associate whether or not the TPCODL is held liable for by any court judgement. In this connection, the TPCODL shall pass on all claims made against him to the Associate for settlement.

The Associate assumes responsibility for and shall indemnify and save harmless the TPCODL from all liability, claims, costs, expenses, taxes and assessments including penalties, punitive damages, attorney's fees and court costs which are or may be required to be paid by the TPCODL and its officers, directors, employees, affiliates, agents, successors and assigns arising from any breach of the Associate's obligations under the Contract or for which the Associate has assumed responsibilities under the Contract including those imposed under any local or national law or laws, or in respect to all salaries, wages or other compensation for all persons employed by the Associate or his Sub-Associates or suppliers in connection with the performance of any work covered by the Contract. The Associate shall execute, deliver and shall cause his Sub-Associate and suppliers to execute and deliver, such other further instruments and to comply with all the requirements of such laws and regulation as may be necessary there under to conform and effectuate the Contract and to protect the TPCODL.

The TPCODL shall not be held responsible for any accident or damages incurred or claims arising, due to the Associate's error there from prior to completion of work. The Associate shall be liable for such accidents and after completion of work for such accidents as the case may be due to negligence on his part to carry out Work in accordance with Indian laws and regulations and the specifications set forth herein.

## 21.0 LIABILITY & LIMITATIONS

### 21.1 Liability

Except for any specific liability which may be identified in the Contract and which may be payable hereunder, Associate shall not be liable for any special, incidental, indirect, or consequential Damages or any loss of business Contracts, revenues or other financial loss (or equivalents thereof no matter how claimed, computed or characterized) arising out of or in connection with the Performance of the Work or supply of Goods ***unless caused by Associate's negligence, willful misconduct or breach of contract.***

TPCODL shall have no liability or any special, incidental, indirect or consequential Damages for any loss of Business Contracts, revenues or other financial loss arising out of this Contract.

### 21.2 Limitation of Liability



Doc. Title	GENERAL CONDITIONS OF CONTRACT - COMPOSITE WORKS	
Rev. No	0	Page 28 of 104

The total liability of Associate against any contract shall be limited to the Total All Inclusive Contract Value.

## **22.0 FORCE MAJEURE**

Force Majeure applies if the performance by either Party ("the Affected Party") of its obligations under Contract is materially and adversely affected.

"Force Majeure" shall mean any event or circumstance or combination of events or circumstances referred below and their consequences that wholly or partly prevents or unavoidably delays any Party in the performance of its obligations under this Agreement, but only and to the extent that such events and circumstances are not within the reasonable control, directly or indirectly, of the Affected Party and could not have been avoided even if the Affected Party had taken reasonable care:

- Act of war (whether declared or undeclared), invasion, armed conflict or act of foreign enemy, embargo, blockade, revolution, riot, bombs, religious strife or civil commotion, etc.
- Politically motivated sabotage, or terrorism, etc.
- Action or Act of Government or Governmental agency for which remedy is beyond the control of the affected parties.
- Any act of God.

Note: Causes like power breakdown/ shortages/fire/strikes, accidents etc do not fall under Force Majeure.

Time being the essence of the Contract, if either party is prevented from the performance of its obligations in whole or in part due to an event of Force Majeure, then provided Notice of happening of any event by the Affected Party is given to the other party within seven (7) days from the date of occurrence of such event, which DIRECTLY has impact on works and submitted details and quantum of resulting effect, but at the same time had made all possible efforts to mitigate and overcome effects thereof, the Affected Party's performance under this Contract shall be suspended until such event ceases and the Scheduled Completion shall be delayed accordingly.

If Force Majeure event(s) continue for a period of more than three months, the parties shall hold consultation to discuss the further course of action.

Neither party shall be considered to be in default or in breach of its obligation under the Contract to the extent that performance of such obligation by either party is prevented by any circumstances of Force Majeure which arise after effective date of Contract.

Neither party can claim any compensation from the other party on account of Force Majeure.

## **23.0 SUSPENSION OF CONTRACT**

### **23.1 Suspension for Convenience**

TPCODL may, at any time and at its sole option, suspend execution of all or any portions of the schedule of items of contract to be supplied/work to executed by Associate under the contract by providing to the Associate atleast two business days written notice for contracts having contract completion period less than sixty days and atleast seven business days' notice for all other contracts.

Doc. Title	<b>GENERAL CONDITIONS OF CONTRACT - COMPOSITE WORKS</b>	
Rev. No	0	Page 29 of 104

Upon receipt of any such notice, the Associate shall respond as follows as applicable as per contract construction.

- Immediately discontinue further supply of material/goods specified in the suspension notice for supply contracts
- Immediately discontinue further service/work and supply of materials of those services/materials/work specified in the suspension notice for service /composite contract
- Promptly make every reasonable effort to obtain suspension, upon terms satisfactory to TPCODL, of all orders, outsourcing arrangements, and rental Contracts to the extent that they relate to performance of the portion of Work suspended by the notice.
- Protect and maintain the portion of the service/Work already completed, including the portion of the Work suspended hereunder, unless otherwise specifically stated in the notice.
- Continue delivering/carrying out the supply/service/work items as per contract conditions, which do not fall under purview of the suspension notice.

On receipt of resumption notice from TPCODL, the Associate shall resume execution of contract as specified in the resumption notice, within the time frame specified in the resumption notice,

### **23.2 Suspension for Breach of Contract conditions.**

TPCODL shall suspend execution of whole/or part thereof the contract till such time Associate complies with the conditions stipulated under section clause 27 for breach/default of contract conditions.

### **23.3 Compensation in lieu of Suspension**

If the suspension of the contract in whole or in part is for convenience of TPCODL and not due to any breach of contract conditions by the associate, TPCODL at its discretion shall consider compensating all reasonable additional costs incurred by Associate in lieu of suspension of whole or part of contract, on representation of the Associate providing justified estimates of such additional costs and such estimates are found acceptable and approved by competent authority of TPCODL.

If the suspension of contract in whole or part thereof is due to breach of contract conditions (refer clause 24.3) by the Associate, Associate shall not be entitled for any compensation for any cost incurred in lieu of suspension of whole or part of contract and also shall be liable for compensating all the losses arising to TPCODL in lieu of suspension of contract. Resumption notice shall be subject to the Associate taking corrective action for the breach of contract conditions within the time frame and as per the terms specified in the suspension notice.

## **24 TERMINATION OF CONTRACTS**

### **24.1 Termination for Default/Breach of Contract**

The contract / PO shall be subject to termination by TPCODL in case of breach of the contract by the Associate which shall include but not be limited to the following:

Doc. Title	GENERAL CONDITIONS OF CONTRACT - COMPOSITE WORKS	
Rev. No	0	Page 30 of 104

- a. Withdrawal or intimation by the Associate of its intent to withdraw or surrender the execution / completion of the contracted work /PO or failure in ensuring adherence to any delivery schedules, in deviation of the contract/ PO.
- b. Refusal or neglect on the part of the Associate to supply material/equipment of quantity or quality as specified by TPCODL and within the timeframe as specified in the contract document or refusal or neglect to execute the services/work in terms of the agreed standards of quantity or quality and/or within the timeframe specified in the contract/PO.
- c. Failure in any respect to perform any portion of the Work contracted with promptness, diligence, or in accordance with the terms of the contract.
- d. Failure to furnish guarantees as specified and /or failure to comply with the terms thereof.
- e. Failure to furnish such relevant documents or information within the time specified which may be necessary for due execution / completion of the works and documentation.
- f. Liquidation, bankruptcy either voluntary or involuntary OR entering into any composition or compromise with its creditors, or Insolvency.
- g. In case any reasonable information has been received by TPCODL that Associate has adopted/ or attempted to adopt any unethical conduct, action in award of the contract /PO or at any time thereafter.
- h. Failure to comply with applicable statutory provisions as contained in the contract or failure to comply with the applicable laws.
- i. Failure to comply with safety regulations/clauses stipulated in the contract or as may be generally instructed by TPCODL.

If the default or breach as specified under clause 24 (except sub clause g thereof) be committed by the associate for the first time, TPCODL shall issue, along with notice of default or breach, a warning notice instructing the associate to take remedial/corrective action within the time frame stipulated in the warning notice and not to repeat the same in future. The timeframe for corrective action by the associate shall be specific to the nature of breach of contract and the same shall not be objected to by the Associate. If the Associate fails to comply with the instructions in the warning notice or in taking corrective action to the satisfaction of TPCODL then TPCODL may terminate the entire or part of contract at its discretion by issuing termination notice without incurring any liability on this ground.

In case the contract is terminated for any breach of the nature specified in clause 24 g stated above, TPCODL shall have the right to terminate all the contracts TPCODL is having with the Associate by issuing termination notice which shall be without prejudice to the other rights of TPCODL available to it under law.

Without prejudice to its right to terminate for breach of contract, TPCODL may, without assigning any reason, terminate the Contract in whole or in part at any time at its discretion while the contract is in force by serving a written notice of two weeks to the Associate.

In the event of TPCODL having proceeded with termination of the contract the associate shall comply and proceed further in the following manner:

- i) Associate shall discontinue the supply, on the expiry of the said period of two weeks.

Doc. Title	GENERAL CONDITIONS OF CONTRACT - COMPOSITE WORKS	
Rev. No	0	Page 31 of 104

ii) Associate shall ensure that no further steps are being taken towards discharge of the obligations, terms and conditions as contained in the contract/PO. This shall include initiation of actions not limited to discontinuation of other allied and associated arrangements which the associate might have entered into with third parties for due discharge of its obligations under the contract with TPCODL.

iii) The Associate shall perform thereafter such tasks as may be necessary to preserve and protect the terminated portion of the material/service/work in progress and the materials and equipment at TPCODL sites or in transit thereto. However the associate shall continue to fulfill its contractual obligations with regard to the part of contract not terminated.

iv) It shall be open for TPCODL to conduct a joint assessment with the associate of the material ,supplies, equipment ,works or in general as to the subject matter of the contract in regard to which the associate claims having completed its obligations before or during such termination.

v) It shall be open to TPCODL to seek invocation of the performance bank guarantee or any other guarantee or other security deposit by whatever name called submitted by the associate, which shall not be objected to or protested against by the associate.

In case of termination of the contract the parties agree to be governed inter alia by the following:

a) In case TPCODL exercises its right of termination as stated above the associate shall not dispute or object to the same.

b) The Associate shall be entitled to receive and claim only such payments OR sums of money from TPCODL as may be found payable to it in regard to works executed by it under the terms of the contract and no other claim of any nature whatsoever shall be made by the Associate.

c) All such provisions which the parties have agreed to survive and prevail even after termination of the contract shall remain effective despite the termination.

In the event of such termination, TPCODL may finish the Work by whatever method it may deem expedient, including the hiring of services and /or purchase of material equipment from such third parties as TPCODL may deem fit or may itself provide any labor or materials and perform any part of the Work. The associate undertakes to bear the incremental costs if any paid by TPCODL in such a case attributable to failure on the part of the associate. The Associate in such a case shall not be entitled to receive any further payments and any sums found payable to it may be adjusted by TPCODL against the amount recoverable from him on this ground. The same shall be without prejudice to other rights available to TPCODL under law against the associate.

Upon the termination of any of the contract due to occurrence of any circumstances provided in clauses stated above and constituting repeated breach or misconduct , TPCODL shall be entitled to bar the associates its agents , affiliates from undertaking any negotiation / tendering, bidding, participation activities concerning TPCODL for a period of two years from date of such termination. The same shall be without prejudice to other rights available to TPCODL.

## **24.2 Termination for convenience of Associate**

Doc. Title	<b>GENERAL CONDITIONS OF CONTRACT - COMPOSITE WORKS</b>	
Rev. No	0	Page 32 of 104

Associate at its convenience may request for termination of contract, clearly assigning the reason for such request. TPCODL has full right to accept, reject or partially accept such request. This convenience will be available to associate only after one year from the contract effective date. For this purpose, associate will provide a notice period of 90 days to TPCODL, Associate will have to pay TPCODL a 'termination convenience fee' equivalent to 5% of unexecuted contract value.

### **24.3 Termination for Convenience of TPCODL**

TPCODL at its sole discretion may terminate the contract by giving 30 days prior notice in writing or through email to the Associate. TPCODL shall pay the Associate for all the supplies/ services rendered till the actual date of contract termination against submission of invoice by the Associate to that effect.

### **25.0 DISPUTE RESOLUTION & ARBITRATION**

In case of any dispute or difference the parties shall endeavor to resolve the same through conciliatory and amicable measures within 15 Days failing which the matter may be referred by either party for resolution by the sole arbitrator to be appointed mutually by both the parties. The arbitral proceedings shall be conducted in accordance with Arbitration and Conciliation Act 1996 and the place of arbitration shall be Bhubaneswar. The language to be used at proceedings shall be English and the award of the arbitrator shall be final and binding on the parties. The parties shall bear their respective costs of arbitration. The associate shall continue to discharge its obligations towards due performance of the works as per the terms of the contract during the arbitration proceedings unless otherwise directed in writing by TPCODL or suspended by the arbitrator. Further, TPCODL shall continue making such payments as may be found due and payable to the associate for such works.

#### **25.1 Governing law and jurisdiction**

The parties shall be subject to the jurisdiction of the courts of law in Bhubaneswar and any matter arising here from shall be subject to applicable law in force in India.

### **26.0 ATTRIBUTES OF GCC**

#### **26.1 Cancellation**

The Company reserves the right to cancel, add, delete at its sole discretion, all or any terms of this GCC or any contract, order or terms agreed between the parties in pursuance without assigning any reasons and without any compensation to the Associates.

#### **26.2 Severability**

If any portion of this GCC is held to be void, invalid, or otherwise unenforceable, in whole or part, the remaining portions of this GCC shall remain in effect.

#### **26.3 Order of Priority**

In case of any discrepancies between the stipulations in General Conditions of the Contract (GCC) and Special Conditions of Contract (SCC), the GCC shall stand superseded by the SCC to the extent stipulated hereinabove while balance portion of respective clauses of GCC shall continue to be applicable.

### **27.0 INSURANCE**

Doc. Title	<b>GENERAL CONDITIONS OF CONTRACT - COMPOSITE WORKS</b>	
Rev. No	0	Page 33 of 104

The Associate shall arrange accident insurance policy for his foreign experts/specialists/personnel deputed to Site and Associate's/his sub-Associates' manufacturing works as well as for his Indian engineers and supervisory staff. The Associate shall also take out for his Indian workmen, where applicable, a separate policy as required under Workmen's Compensation Act.

Associates shall be responsible to suitably insure their entire work-force (to the extent of at least meeting requirements under Workmen Compensation Act) Tools, Plant, Third party liability at the project site, All Risk comprehensive insurance for the entire works (insurance for free issue items will be in TPCODL scope) for total contract (PO/RO) value or any other such risks during execution of works, till the works are handed over to the company, in consultation with TPCODL and shall submit copies of such insurances to the Engineer-in-Charge for review / acceptance before commencing the work. Engineer-in-charge must ensure compliance to insurance requirement by Associate before commencement of works. TPCODL shall stand fully indemnified in this respect.

### **28.0 ERRORS AND OMISSIONS**

The Associate shall be responsible for all discrepancies, errors and omissions in the drawings, documents or other information submitted by him, irrespective of whether these have been approved, reviewed or otherwise accepted by the TPCODL or not. However any error in design/drawing arising out of any incorrect data/written information from TPCODL will not be considered as error and omissions on part of the Associate.

### **29.0 TRANSFER OF TITLES**

The title of ownership and property to all equipment, installations, erections, constructions materials, drawings & documents shall pass to the TPCODL after Commissioning and complete handing over-taking over.

However, such passing of title of ownership and property to the TPCODL shall not in any way absolve, dilute or diminish the responsibility and obligations of the Associate under this Contract including loss or damages and all risks, which shall vest with the Associate.

The Associate shall take all corrective measures arising out of discrepancies, errors and omissions in drawings and other information within the time schedule and without extra cost to the TPCODL.

The Associate shall also be responsible for any delay and/or extra cost if any, in carrying out engineering, and site works by other agencies arising out of discrepancies, errors and omissions stated in as well as of any late revision/s of drawings and information submitted by the Associate.

### **30.0 SUGGESTIONS & FEEDBACK**

We welcome all our Business Associates to write to us about their experience with TPCODL; be it our Company, our services or our people. Each and every concern, issue, query and suggestion from you will help us to become a better company to work with and shall help us develop a strong bonding of trust and a long term relationship with you.

You may send your feedback by filling up our Business Associate Feedback Form enclosed herewith as Annexure-I. You can also log on to our website [www.tpcentralodisha.com](http://www.tpcentralodisha.com) to provide your feedback according to the guidelines mentioned below:

Doc. Title	<b>GENERAL CONDITIONS OF CONTRACT - COMPOSITE WORKS</b>	
Rev. No	0	Page 34 of 104

### 31.0 CONTACT POINTS

In case Business Associate needs information with respect to payments or has any grievances, same may be lodged by log on to our website [www.tpcentralodisha.com](http://www.tpcentralodisha.com)

### 32.0 LIST OF ANNEXURES

S. No.	Subject	Annexure
1.	Performa for Bid Security Bank Guarantee	A
2.	Performa for Advance Payment Bank Guarantee	B
3.	Performa for Performance Bank Guarantee (CP cum EP)	C
4.	Performa for No Demand Certificate by Associate	D
5.	Performa for Indemnification on Statutory Compliance	E
6.	Performa For Application For Issuance of Consolidated TDS Certificate	F
7.	HR Service Level Agreement	G
8.	Under taking for competence of workmen	H
9.	Business Associate Feedback Form	I
10.	Acceptance Form For Participation In Reverse Auction Event	J
11.	NEFT or RTGS payment request form	K
12.	Contractor Safety Management System	L
13.	Vendor Appraisal Form	M
14.	Manufacturers Authorization Form	N





Doc. Title	GENERAL CONDITIONS OF CONTRACT - COMPOSITE WORKS	
Rev. No	0	Page 36 of 104

**ANNEXURE-B**

**PROFORMA FOR ADVANCE PAYMENT BANK GUARANTEE**

**(On Rs.100/- Stamp Paper)**

**Note:**

- (a) Format shall be followed in toto
- (b) Claim period of six months must be kept up
- (c) The guarantee to be accompanied by the covering letter from the bank confirming the signature to the guarantee

-----  
-----

**TP Central Odisha Distribution Limited**

**Bhubaneswar**

**Advance Payment B.G.No.....**

**Contract No.....dated.....**

1. You have entered into a Contract No \_\_\_\_\_ with M/s. \_\_\_\_\_ (hereinafter referred to as "the Vendor") for the supply and delivery of \_\_\_\_\_ (hereinafter referred to as "the said Equipment") for the price and on the terms and conditions contained in the said contract.
2. In accordance with the terms of the said contract, you have agreed to make an advance payment of Rs. \_\_\_\_\_ (Rupees \_\_\_\_\_ only) being \_\_\_\_\_% (\_\_\_\_\_percent) of the total value of the contract on "the Vendor" furnishing you with an irrevocable, unconditional and acceptable bank guarantee to be valid till the date of receipt of "the said equipment" covered by your above mentioned contract. For this purpose you have agreed to accept our guarantee.
3. In consideration thereof, we, \_\_\_\_\_ hereby irrevocably and unconditionally guarantee to pay to you on demand but in any case before the end of five working days from the date of the claim and without demur and without reference to "the Vendor" such amount or amounts not exceeding the sum of Rs. \_\_\_\_\_ (Rupees \_\_\_\_\_ only) being \_\_\_\_\_% (\_\_\_\_\_percent) of the total value of the contract on receipt of your intimating that "the Vendor" has not fulfilled his contractual obligations. You shall be the sole judge for such non-fulfillment and "the Vendor" shall have no right to question such judgment.
4. You shall have the right to file / make your claim on us under the guarantee for a further period of one months from the date of expiry.
5. This guarantee shall not be revoked without express consent and shall not be affected by your granting time or any other indulgence to "the Vendor", which shall include but

Doc. Title	GENERAL CONDITIONS OF CONTRACT - COMPOSITE WORKS	
Rev. No	0	Page 37 of 104

not be limited to, postponement from time to time of the exercise the same in you or any right which you may have against "the Vendor" and to exercise the same in any covenant contained or implied in the said contract or any other course or remedy or security available to you, and our Bank shall not be released from its obligations under this guarantee by your exercising any of your rights with reference to matters aforesaid or any of them or by reasons of any other act or forbearance or other acts of omission or commission on your part or any other indulgence shown by you or by any other matter or thing whatsoever which under the law would, but for this provision have the effect of relieving our bank from its obligation under this guarantee.

6. We also agree that you shall be entitled at your option to enforce this guarantee against our bank as a principal debtor, in the first instance, notwithstanding any other security or guarantee that you may have in relation to "the Vendor's" liabilities in respect of the premises
7. This guarantee shall not be affected by any change in the constitution of our Bank or "the Vendor" or for any other reason whatsoever.
8. Any claim / extension under the guarantee can be lodge-able at outstation banks or at Bhubaneswar branch and claim will also be payable at Bhubaneswar Branch **(to be confirmed by Bhubaneswar Branch by a letter to that effect)**
9. Notwithstanding anything herein contained, our liability under this guarantee is limited to Rs. \_\_\_\_\_ (Rupees \_\_\_\_\_ only) and the guarantee will remain in force upto and including \_\_\_\_\_ (Date) and shall be extended from time to time for such period or period as may be desired by "the Vendor".
10. Unless a demand or claim under this guarantee is received by us in writing within one month from \_\_\_\_\_ (expiry date) i.e. on or before \_\_\_\_\_ (claim period end date), we shall be discharged from all liabilities under this guarantee thereafter.

Dated at \_\_\_\_\_ this \_\_\_\_\_ day of \_\_\_\_\_ 200 \_\_\_\_\_

**Witness**

- |          |  |
|----------|--|
| 1. _____ | Bank's rubber stamp<br>Banks full address        |
| 2. _____ | Designation of Signatory<br>Bank official number |

Doc. Title	GENERAL CONDITIONS OF CONTRACT - COMPOSITE WORKS	
Rev. No	0	Page 38 of 104

**ANNEXURE- C**

**PROFORMA FOR PERFORMANCE BANK GUARANTEE (CP cum EP)**

**(On Rs.100/- Stamp Paper)**

**Note:**

- (a) Format shall be followed in toto
- (b) Claim period of one month must be kept up
- (c) The guarantee to be accompanied by the covering letter from the bank confirming the signature to the guarantee

-----  
-----

**TP Central Odisha Distribution Limited**

**Bhubaneswar**

**CP cum EP BG No.....**

**Order/Contract No.....dated.....**

1. You have entered into a Contract No \_\_\_\_\_ with M/s. \_\_\_\_\_ (hereinafter referred to as "the Vendor") for the supply cum erection / civil work of \_\_\_\_\_ (hereinafter referred to as "the said Equipment") for the price and on the terms and conditions contained in the said contract.
2. In accordance with the terms of the said contract, "the Vendor" agreed to furnish you with an irrevocable, unconditional and acceptable bank guarantee for 10% of the value of contract and to be valid till the end of Guarantee period plus one month towards "Contract cum Equipment performance". For this purpose you have agreed to accept the guarantee.
3. In consideration thereof, we, \_\_\_\_\_ hereby irrevocably and unconditionally guarantee to pay to you on demand but in any case before the end of five working days from the date of the claim and without demur and without reference to "the Vendor" such amount or amounts not exceeding the sum of Rs. \_\_\_\_\_ (Rupees \_\_\_\_\_ only) being \_\_\_\_\_ % (\_\_\_\_\_ percent) of the total value of the contract on receipt of your intimating that "the Vendor" has not fulfilled his contractual obligations. You shall be the sole judge for such non-fulfillment and "the Vendor" shall have no right to question such judgment.
4. You shall have the right to file / make your claim on us under the guarantee for a **further period of one month** from the date of expiry.
5. This guarantee shall not be revoked without express consent and shall not be affected by your granting time or any other indulgence to "the Vendor", which shall include but not be limited to, postponement from time to time of the exercise the same in you or any right which you may have against "the Vendor" and to exercise the same in any covenant contained or implied in the said contract or any other course or remedy or security

Doc. Title	GENERAL CONDITIONS OF CONTRACT - COMPOSITE WORKS	
Rev. No	0	Page 39 of 104

available to you, and our Bank shall not be released from its obligations under this guarantee by your exercising any of your rights with reference to matters aforesaid or any of them or by reasons of any other act or forbearance or other acts of omission or commission on your part or any other indulgence shown by you or by any other matter or thing whatsoever which under the law would, but for this provision have the effect of relieving our bank from its obligation under this guarantee.

6. We also agree that you shall be entitled at your option to enforce this guarantee against our bank as a principal debtor, in the first instance, notwithstanding any other security or guarantee that you may have in relation to "the Vendor's" liabilities in respect of the premises
7. This guarantee shall not be affected by any change in the constitution of our Bank or "the Vendor" or for any other reason whatsoever.
8. Any claim / extension under the guarantee can be lodge-able at outstation banks or at Bhubaneswar branch and claim will also be payable at Bhubaneswar Branch (to be confirmed by Bhubaneswar Branch by a letter to that effect in case BG is from the branch outside Bhubaneswar)
9. Notwithstanding anything herein contained, our liability under this guarantee is limited to Rs. \_\_\_\_\_ (Rupees \_\_\_\_\_) only and the guarantee will remain in force upto and including \_\_\_\_\_ (Date) and shall be extended from time to time for such period or period as may be desired by "the Vendor".
10. Unless a demand or claim under this guarantee is received by us in writing within one months from \_\_\_\_\_ (expiry date) i.e. on or before \_\_\_\_\_ (claim period end date), we shall be discharged from all liabilities under this guarantee thereafter.

Dated at \_\_\_\_\_ this \_\_\_\_\_ day of \_\_\_\_\_ 200\_\_

**Witness**

- |          |  |
|----------|--|
| 1. _____ | Bank's rubber stamp<br>Banks full address        |
| 2. _____ | Designation of Signatory<br>Bank official number |

Doc. Title	GENERAL CONDITIONS OF CONTRACT - COMPOSITE WORKS	
Rev. No	0	Page 40 of 104

**ANNEXURE-D**

**PROFORMA FOR “NO DEMAND CERTIFICATE” BY ASSOCIATE**

(On Company’s Letter head or with Company Seal)

(To be submitted by the Associate to TPCODL Accounts Department at the time of receipt of full and final payment)

**(Certificate No. CCP/002)**

Name of the Project

Order/ Contract No.

Dated

Name of the Associate

Scheme No. / Job No.

We, M/s. \_\_\_\_\_ (Associate) do hereby acknowledge and confirm that we have received the full and final payment due and payable to us from TPCODL, in respect of our aforesaid Order No \_\_\_\_\_ dated \_\_\_\_\_ including amendments, if any, issued by TPCODL to our entire satisfaction and we further confirm that we have no claim whatsoever pending with TPCODL under the said contract / W.O.

Notwithstanding any protest recorded by us in any correspondence, documents, measurement books and / or final bills etc., we waive all our rights to lodge any claim or protest in future under this contract.

We are issuing this “NO DEMAND CERTIFICATE” in favour of TPCODL, with full knowledge and with our free consent without any undue influence, misrepresentation, coercion etc.

**Dated**

**Signature**

**Place**

**Name**

**Designation**

**(Company Seal)**

Doc. Title	GENERAL CONDITIONS OF CONTRACT - COMPOSITE WORKS	
Rev. No	0	Page 41 of 104

**ANNEXURE – E**

**PROFORMA FOR “INDEMNIFICATION ON STATUTORY COMPLIANCES”**

(To be submitted by the successful Bidder within seven days of award of work)

**(Certificate No. CCP/001)**

Name of the Project

Letter of Award / Contract No.

Dated

Name of the Associate

Scheme No. / Job No.

By this confirmation we, \_\_\_\_\_  
(Associate) are formally bound to M/s. TPCODL towards any sum which may be imposed, levied or hereinafter recovered by the Provident Fund Organization under the provisions of the Employees of the Provident Fund and Miscellaneous Provisions Act 1952 in respect of employees employed by us.

We well and truly bind ourselves and our heirs executors administrators and representatives jointly severally and respectively for the above payment only to be paid to M/s. TPCODL.

AND WHEREAS we, \_\_\_\_\_ (Associate) is making compliance of the Employees Provident Fund and Miscellaneous Provisions Act 1952, have entered into the above written bond for the indemnity to M/s. TPCODL against all losses from the acts or default of the said Associate in respect of compliance of the Provident Fund Act.

Similarly we hereby confirm that we have complied with all statutory and local laws and nothing is outstanding with regard to Local Sales Tax, Labour Laws, Local Municipal dues, Electricity dues etc. We have entered into the above written bond for the indemnity to M/s. TPCODL against all losses from the acts or default of the said Associate in respect of compliance of the Local Sales Tax Laws, Local Laws, Labour Laws, Local Municipal Dues, Electricity dues etc.

NOW THE CONDITION, of the above written bond is as such that if the Associate during the period of this contract commits any default or fails to make payment of Contributions in respect of his employees to the Employees Provident Fund Organization, he shall indemnify the Principal Employer M/s. TPCODL from all and every loss and damage caused to them from any act, omissions or negligence of the said Associate in respect of compliances under the Employees Provident Fund and Miscellaneous Provisions Act, 1952.

IN WITNESS to the above written bond we have here to set our hands, with our free consent.

**Dated**

**Signature**

**Place**

**Name**

**Designation (Company Seal)**

Doc. Title	GENERAL CONDITIONS OF CONTRACT - COMPOSITE WORKS	
Rev. No	0	Page 42 of 104

**ANNEXURE-F**

**PROFORMA FOR APPLICATION FOR ISSUANCE OF CONSOLIDATED TDS  
CERTIFICATE**

To be printed on the letterhead

To,

TP Central Odisha Distribution Limited,

Bhubaneswar

**Sub: Application for issuance of Consolidated TDS Certificate for the FY \_\_\_\_\_**

Dear Sir,

I / we hereby request / authorize you to issue me / us a consolidate TDS Certificate for the financial year \_\_\_\_\_ against tax deducted at source by you from my / our payments / bills during the said year from time to time under Chapter XVII – B of the Income Tax Act, 1961.

For and on behalf of

Signature

Name

Address

Contact No. (Land Line)

(Mobile)

PAN #

Assessing authority

**ATTACH THE COPY OF PAN CARD**



Doc. Title	GENERAL CONDITIONS OF CONTRACT - COMPOSITE WORKS	
Rev. No	0	Page 43 of 104

## ANNEXURE - G

### SERVICE LEVEL AGREEMENT

(To be adhered to by Business Associates (BAs) in TPCODL on Human Resource Issues)

**1.0 The following shall be adhered to by the Business Associates during his / its association with TPCODL:**

**Shall Abide by TPCODL Core Values:**

- a) **Integrity** – We must conduct our business fairly, with honesty and transparency. Everything we do must stand the test of public scrutiny.
- b) **Understanding** – We must be caring, show respect, compassion and humanity to our colleagues and customers and always work for the benefit of the communities we serve.
- c) **Excellence** – We must constantly strive to achieve the highest possible standards in our day to day work and in the quality of services we provide.
- d) **Unity** – We must work cohesively with our colleagues across the group and with our customers and partners to build strong relationships based on tolerance, understanding and mutual co-operation.
- e) **Responsibility** – We must continue to be responsible and sensitive to the communities and environments in which we work and always ensuring that what comes from the people; goes back to the people many times over.
- f) **Agility**- We must work in a speedy and responsive manner and be proactive and innovative in our approach.

**2.0 The Business Associate / his manager / supervisor who is responsible for managing the project site / performance contract etc. in TPCODL would also ensure adherence of these values by his employees / persons deployed by him in connection with his works undertaken in TPCODL.**

**3.0 TPCODL is a signatory to the United Nation Global Compact as an integral part of its Governance principles / business. The Business Associates are required to:**

- a) Support and respect the protection of human rights and make sure that they are not complicit in human right abuses.
- b) Respect freedom of association and effective recognition of the right to collective bargaining.
- c) Not to resort to any form of forced and compulsory labour.
- d) Shall ensure abolition of child labour in his area of work.
- e) There is no discrimination in respect of employment and occupation in respect of his employees.
- f) Support precautionary approach to environmental challenges.
- g) Promote greater environmental responsibility by himself and his employees in his areas of work.
- h) Deploy and defuse environmental friendly technologies while carrying out the works.
- i) Work against corruptions in all its form including extortion and bribery by himself and his employees.

**4.0 The Business Associates are required to adhere to all applicable Labour Laws with special reference to the following:**

Doc. Title	GENERAL CONDITIONS OF CONTRACT - COMPOSITE WORKS	
Rev. No	0	Page 44 of 104

- a) No person below the age of 18 years and no child labour will be engaged directly or indirectly for executing the work connected with the business of TPCODL.
- b) Minimum wages along with other statutory dues like PF, ESI, etc. as applicable to the workers shall be made within the prescribed period of 7<sup>th</sup> / 10<sup>th</sup> day of the following month.
- c) Deduction / deposit / record keeping and all other requirements under Employees PF Act 1952, Employees State Insurance Act 1948 and other applicable acts (if any) shall be adhered to.
- d) Only statutorily authorized deductions (if any) shall be made in accordance with the relevant statutes.
- e) All the provisions of Contract Labour (R&A) Act 1970 shall be complied with in respect of the workers engaged for TPCODL work. The work will be commenced only after completing necessary formalities for obtaining Labour License (if applicable).
- f) Necessary registers / records, filing of returns etc. shall be maintained for verification by Statutory / TPCODL authorities.
- g) Payment of wages shall be made only in presence of and with certification of authorized representative of TPCODL or shall be made in the form of cheque / bank transfer to the employee.
- h) During the period of contract, the Business Associate will arrange for deployment of his supervisor / manager for total supervision and control of the work and their manpower. All the activities related to their manpower e.g. attendance, leave, wage disbursement etc. will be done under the supervision & control of Business Associates, While adhering to the prescribed standard / norms of production / productivity & quality. During execution of the work, Business Associate shall engage only such qualified / skilled manpower as may be envisaged / required for ensuring level of production / service into the contract / work order.
- i) Clearances as follows shall be obtained from IR & Welfare Group:
  - i. Clearance for commencement (before start of the work).
  - ii. No Objection Certificate (after completion / before final settlement).
  - iii. Copies of PF / ESI Challans shall be deposited with IR & Welfare Group every month
- j) The Business Associate shall indemnify TPCODL from any liabilities under applicable Labour Statutes.
- k) The Business Associate shall ensure safety and health of his employees and shall also maintain hygienic working environment / condition in his area of work.
- l) The Business Associate and his employee shall abide by Laws of Land and shall not violate any applicable provisions.
- m) The Business Associate appreciates with and acquiesces to the right of TPCODL as principal employer to fulfil any of his legal obligations, if he fails to do so under applicable labour laws and deduct the same from his running bills / final payments / encashing security deposit / Bank Guarantee as the case may be. If there is any further shortfall TPCODL has the right to recover the same from the Business Associate.
- n) The Business Associate ensures that person employed by him adhere to the moral and legal conduct and shall not violate any standard conduct envisaged in the premise of

Doc. Title	GENERAL CONDITIONS OF CONTRACT - COMPOSITE WORKS	
Rev. No	0	Page 45 of 104

TPCODL by all such as, Transparency, Safety, Discipline, Integrity etc. The Business Associate or his employees should refrain from corrupt practices, giving or taking bribe in connection with any TPCODL business.

**5.0 The 'Statutory Compliance Enforcement System' in TPCODL is detailed below for adherence by all concerned. Corporate IR & Welfare Group will be the process owner for implementation of the system with the help of concerned Engineer I/c or Officer I/c.**

- a) Statutory Compliance being a professed value in TPCODL Code of Conduct, the concerned Engineer / Officer in charges are requested to adhere to the provisions and advise respective Business Associates in their domain to comply in letter and spirit.
- b) Immediately after issuance of letter of intent, the authorized representative of the Business Associate will report to Corporate IR & Welfare group for completion of statutory requirements.
- c) Normally, the work will be started only after 'Clearance for Commencement of Work (CCW)' is issued by IR & W group to the Business associate. However in exceptional exigencies in engineer I/c / Officer I/c may direct the Business Associate to start the work and inform IR & W group about the same. Statutory requirements in this case may be completed parallely.
- d) First monthly bill will be released only after producing CCW to the finance department. Similarly closure of work and final settlement will be affected after issuance of no objection certificate from IR & W group.

**6.0 Requirements for 'Clearance for Commencement of Work' (CCW):**

- a) Submission of filled up Form 'A' for database (Annexure-1).
- b) Copy of PF Code allocation letter.
- c) Copy of ESI Code allocation letter.
- d) Submission of duly filled up Form IV CL(R&A) act (In case more than or equals to 20 workers during the period of contract).
- e) Submission of duly filled up Form VI A (Notice of Commencement).
- f) Copy of insurance cover note under WC Act 1923 (if applicable).
- g) Copy of Contract Agreement.
- h) Copy of indemnity bond (if applicable).
- i) Affidavit with regard to payment of wages through cheque / bank transfer only.

**7.0 Requirements during execution of work:**

- a) Copy of receipt of application for license / license (if applicable).
- b) Copy of PF Challan (latest by 26<sup>th</sup> day of every Month).
- c) Copy of ESI Challan (latest by 26<sup>th</sup> day of every Month).
- d) Copy of Wage disbursement sheet / Bank statement.
- e) Filing / Maintenance of all statutory registers / reports / returns for inspection by Statutory/ TPCODL authorities.
- f) Certification of wage disbursement by authorized representative of TPCODL.
- g) Copy of 'Labour Welfare Fund' deposit certificate / Challan.
- h) Insuring safe working practices at the work place.

**8.0 Requirements for 'No Objection Certificate' (NOC) for closure of work:**

- a) Submission of duly filled up Form VI A (Notice of Completion).

Doc. Title	GENERAL CONDITIONS OF CONTRACT - COMPOSITE WORKS	
Rev. No	0	Page 46 of 104

- b) Copy of Half yearly / Annual return for ESI / PF / CL(R&A).
- c) Consolidated copy of wage sheet of last month indicating full & final settlement of all dues like retrenchment benefit, bonus, leave encashment etc. Copy of individual declaration by employees in Form X regarding termination of employment.
- d) Confirmation certificate regarding filling up of form for transfer / withdrawal of PF by the concerned workers.

**In case any of the above are deviated / not complied with the Letter of Award/Order shall be liable to be withdrawn / cancelled.**

**Enclosure:**

- 1) Form A
- 2) Form X
- 3) Form XI
- 4) Form VI A
- 5) Form XXIV

GENERAL CONDITIONS OF CONTRACT

Doc. Title	GENERAL CONDITIONS OF CONTRACT - COMPOSITE WORKS	
Rev. No	0	Page 47 of 104

**FORM (A)**

**[To be submitted by the Business Associate to the Principal Employer within a week from LoA issuance]**

**A. Details of the Agency**

1. Name of Agency :
2. Nature of work :
3. Local Address with Ph.No. :  
(With Father's name) :
4. Permanent Address (Full) :
5. PF code no. & Place :
6. ESI Code no. & Place :
7. Name and address of :  
Sub-contractor (if any)

**B. Details of Work**

8. Name of work (as specified in LOI/LOA) :
9. LOI/LOA Nos. & Dates :
10. Period of contract (Specify Dates) :  
[Including Extension period, if any] :
11. Work Area [Department / Location] :
12. Name / Cell no. of Officer I/c :
13. Maximum No. of workers and staff to be engaged on any day during the year.
  - Supervisory Staff :
  - Workers :
14. Do you have any other contract in TPCODL : Yes/No  
If yes, furnish details:

Doc. Title	GENERAL CONDITIONS OF CONTRACT - COMPOSITE WORKS	
Rev. No	0	Page 48 of 104

15. Details of Workmen's compensation Policy, if applicable

Name of Insurance Company .....  
 .....Policy No ..... Number of persons covered .....  
 Period of coverage: From ..... To .....

If no, I hereby undertake the liability arising out of Workmen's Compensation Act and Rules made there under.

**C. Details of workers to be engaged**

**No. of Workers**

S. No.	Unskilled*	Semi-skilled*	Skilled*	Clerical / Supervisory

**\* Number to be indicated**

I/We shall fulfill all obligations arising from and under all relevant law in force from time to time. I/We undertake to keep the TPCODL indemnified against any loss or liability arising out of failure of my / our abiding the relevant laws.

The name of my / our representatives is ..... to enter the TPCODL Premises on my behalf.

**Date:**

**(Signature of the Business Associate  
 or his Authorized Representative)**

**This Business Associate is / will be engaged in TPCODL.**

**(Signature and seal of**

**Officer I/c of the Work)**

Doc. Title	GENERAL CONDITIONS OF CONTRACT - COMPOSITE WORKS	
Rev. No	0	Page 49 of 104

**Form X**

**Undertaking**

I \_\_\_\_\_ hereby undertake that all the dues in respect of my employment with M/s \_\_\_\_\_ for the period of \_\_\_\_\_ to \_\_\_\_\_ have been settled and final payments including retrenchment benefit have been made to me in full.

( \_\_\_\_\_ )

\_\_\_\_\_

Date:

GENERAL CONDITIONS OF CONTRACT

Doc. Title	GENERAL CONDITIONS OF CONTRACT - COMPOSITE WORKS	
Rev. No	0	Page 50 of 104

**Form XI**

**Undertaking**

With reference to the contract job awarded by M/s TP Central Odisha Distribution Limited to M/s \_\_\_\_\_ vide work order No. \_\_\_\_\_ dated \_\_\_\_\_

I \_\_\_\_\_ on behalf of

M/s \_\_\_\_\_ hereby undertake:

1. that the dues in respect of the workmen/ employee(s) engaged by us for the said contract, payable as per the provisions of relevant statute pertaining to
  - i. wages/ salary
  - ii. PF & ESI, Bhubaneswar Labour Fund
  - iii. All other statutory obligation
 has been paid /settled in full and no amount/ compliance is due/ pending.
  
2. That in case any dispute / claim is raised by the concerned workers i.r.o. any dues / payments, M/s \_\_\_\_\_ will settle the same on it's own and such liability will be borne by M/s \_\_\_\_\_
  
3. That M/s \_\_\_\_\_ hereby indemnify M/s TPCODL from any future liability i.r.o. any statutory obligation in respect of said contract.

Date:

\_\_\_\_\_  
( )

Authorized Signatory

For M/s \_\_\_\_\_



Doc. Title	GENERAL CONDITIONS OF CONTRACT - COMPOSITE WORKS	
Rev. No	0	Page 51 of 104

**FORM- VI A**

**Notice for Commencement /Completion of contract work**

I/We, Sh. / M/s \_\_\_\_\_ (Name and Address of the Contractor) hereby intimate that the contract work \_\_\_\_\_ (name of work) in establishment of the \_\_\_\_\_ (name and address of the Principal Employer) for which License No. \_\_\_\_\_ dated \_\_\_\_\_ has been issued to me/us by the Licensing Officer \_\_\_\_\_ (name of the Headquarters), has been commenced / completed with effect from \_\_\_\_\_ date / on date.

**Signature of Contractor**

**With Office Seal**

**The Inspector**

\_\_\_\_\_  
\_\_\_\_\_

**FORM XXIV**

[See Rule 82(1)]

***Return to be sent by the Contractor to the licensing Officer (in duplicate)***

Half -Yearly Ending \_\_\_\_\_

1. Name and address of the Contractor
2. Name and address of the Establishment
3. Name and address of the Principal Employer
4. Duration of Contract: From \_\_\_\_\_ to \_\_\_\_\_
5. No. of days during the half year on which
  - (a) the establishment of the principal employer had worked
  - (b) the contractor's establishment had worked
6. Maximum No. of contract labour employed on any day during the half –year:

Men	Women	Children	Total

7.
  - (i) Daily hours of work and spread over
  - (ii)
    - (a) whether weekly holiday observed and on what day
    - (b) if so, whether it was paid for
  - (iii) No. of man – hours of overtime worked

8. No. of man days worked by

Men	Women	Children	Total

9. Amount of wages paid

Men	Women	Children	Total

10. Amount of deductions from wages, if any

Men	Women	Children	Total

Whether the following have been provided –

- (i) Canteen : \_\_\_\_\_
- (ii) Rest rooms : \_\_\_\_\_

Doc. Title	GENERAL CONDITIONS OF CONTRACT - COMPOSITE WORKS	
Rev. No	0	Page 53 of 104

(iii) Drinking water : \_\_\_\_\_

(iv) Crèches : \_\_\_\_\_

(v) First Aid : \_\_\_\_\_

**Signature of contractor**

Place \_\_\_\_\_

Date \_\_\_\_\_

GENERAL CONDITIONS OF CONTRACT

Doc. Title	GENERAL CONDITIONS OF CONTRACT - COMPOSITE WORKS	
Rev. No	0	Page 54 of 104

**ANNEXURE – H**

**UNDERTAKING FOR COMPETENCE OF WORKMEN**

Name of Associate :

Tender No. :

Item :

With reference to the tender mentioned above, I/We \_\_\_\_\_,  
hereby undertake that the workmen/ employee(s) engaged by M/s  
\_\_\_\_\_ for the job against said tender shall be competent in all  
respect, commensurate to the nature of job.

Date:

\_\_\_\_\_  
( )

Authorized Signatory

For M/s

Seal

Doc. Title	GENERAL CONDITIONS OF CONTRACT - COMPOSITE WORKS	
Rev. No	0	Page 55 of 104

**ANNEXURE-I**

**BUSINESS ASSOCIATE FEEDBACK FORM**

With an objective to improve our internal processes and systems, and serve you better, we solicit your valuable feedback & suggestions. It is estimated that it will take about 10 minutes to complete this survey. We assure you that your feedback shall be kept confidential. Please send the duly filled feedback form in the "TPCODL addressed - attached envelop"

**You are associated with us as**

- OEMs       Service Contractor       Material Suppliers       Material & Manpower Supplier

**You are associated with us for**

- Less than 1 year       More than 1 year but less than 3 years       More than 3 years

**Your office is located at**

- Bhubaneswar       Within 200 kms from Bhubaneswar       More than 200 kms from Bhubaneswar

**Your nearly turnover with TPCODL**

- Less than 25 Lacs       25 Lacs to 1 Crore       More than 1 Cr.

**Additional information**

<b>Your Name</b>	
<b>Your Designation</b>	
<b>Your Organization</b>	
<b>Contact Nos.</b>	
<b>Email</b>	

*We once again thank you for your participation in this survey. Please spare 10 minutes to give your feedback on following pages (Section A to E)*

Doc. Title	GENERAL CONDITIONS OF CONTRACT - COMPOSITE WORKS	
Rev. No	0	Page 56 of 104

### SECTION - A

(Please ✓ mark in the relevant box and give your remarks / suggestions / information for our improvement.).

S. No.	Parameters	1	2	3	4	5	Remarks/ Suggestion
		Do Not Agree	Slightly in Agreement	In Fair Agreement	Mostly in Agreement	Fully Agree	
1	You receive all relevant queries / tenders from us in timely manner.						
2	We provide you enough lead time to respond to our queries / tenders.						
3	We provide you adequate support (drawings, documents, clarifications, briefing etc.) to enable you meet our requirements.						
4	All following elements of our contract / purchase order are rational :						
4.1	Scope of Work						
4.2	Delivery / Execution Schedule						
4.3	Payment Terms						
4.4	Liquidated Damages						
4.5	Performance Guarantee						
5	Our purchase orders / contracts are simple, specific & easy to understand						
6	TPCODL demonstrate willingness to be flexible in administration of Contract / Purchase Order						
7	We provide timely responses / clarifications to your queries						
8	TPCODL representative you interact / coordinate with is adequately empowered to support you in meeting contractual obligations						
9	TPCODL provide you all necessary infrastructure support for timely and quality completion of work (including AMC)						
10	TPCODL Engineer-in-Charge timely certifies the jobs executed/ material supplied						

S. No.	Parameters	1	2	3	4	5	Remarks/ Suggestion
		Do Not Agree	Slightly in Agreement	In Fair Agreement	Mostly in Agreement	Fully Agree	
11	TPCODL Engineer-in-Charge efficiently supervises the job execution for timely completion of job						
12	BIRD (Bill Inward Receipt Desk) initiative has improved payment disbursement process						
13	Our approach for Inspection and Quality Assurance effective to expedite project completion?						
14	TPCODL never defaults on contractual terms						
15	In TPCODL Contracts closure is done within set time limit						
16	Our material receiving procedures are well defined and efficiently deployed to reduce mutual inconvenience						
17	Bank Guarantees are released in time bound manner						
18	Our processes related to payment / account settlement are effective.						
19	You get payments on time						
20	TPCODL Employees follow Ethical behaviour						

Doc. Title	GENERAL CONDITIONS OF CONTRACT - COMPOSITE WORKS	
Rev. No	0	Page 58 of 104

**SECTION - B**

(Please rate the following parameters on a scale of 1 to 5, where 1 - Minimum; 5 - Maximum)

SN	Parameters	1	2	3	4	5	Remarks/ Suggestion
1	How do you rate courtesy/ empathy/ attitude level and warmth of TPCODL employees you interact with from following team?						
1.1	Project Engineering						
1.2	District / Zones						
1.3	Projects/HOG (TS &P)						
1.4	Inspection & Quality Assurance						
1.5	Stores						
1.6	Metering & Billing						
1.7	Accounts / Finance						
1.8	Administration						
1.9	IT & Automation						
2	How would you rate TPCODL in comparison to your other clients in terms of <b>fairness of treatment and transparency</b> with its Business Associates?						
3	How would you rate TPCODL in comparison to your other clients in terms of <b>processes and systems to manage partnership</b> with its Business Associates						
4	How would you rate TPCODL in comparison to your other clients in terms of <b>building long term &amp; mutually relationship</b> with its Business Associates						



**SECTION-C**

Please ✓ mark in the relevant box and give your remarks / suggestions / information for our improvement.

SNo	Parameters	Certainly NO	Probably NO	Probably YES	Certainly YES	Remarks/ Suggestion
1	Based on your experience with TPCODL, would you like to continue your relationship with TPCODL?					
2	If someone asks you about TPCODL, would you talk "positively" about TPCODL?					
3	Would you refer TPCODL name to others in your community, fraternity and society as a professional & dynamic organization?					

**SECTION - D**

**If we ask you to rate us on a scale of 1 to 10, how will you rate TPCODL, that truly represents your overall satisfaction with us (please tick appropriate box) -**

1	2	3	4	5	6	7	8	9	10
---	---	---	---	---	---	---	---	---	----

Doc. Title	GENERAL CONDITIONS OF CONTRACT - COMPOSITE WORKS	
Rev. No	0	Page 60 of 104

### SECTION – E

Please ✓ mark in the relevant box and give your remarks / suggestions / information for our improvement.

Please spare your thoughts for TPCODL's improvement in particular areas of weaknesses, particularly relating to some great practices, attitudes that you have seen elsewhere in Indian and International Organizations, which you recommend TPCODL to adopt. Please give your valuable salient recommendations.

Please spare your thoughts for TPCODL's improvement in particular areas of major concerns for you. We also welcome your suggestions to adopt any best practices, attitudes that you have observed / experienced elsewhere in Indian/ International organization.

Recommendation	<i>Please tick (✓) your top 5 expectations out of the following 10 points listed below -</i>	
(Please list down improvement you expect from TPCODL)	<i>Timely payment</i>	
1	<i>Flexibility in Contracts/PO</i>	
	<i>Clarity in PO,s &amp; Contracts</i>	
2	<i>Timely response to quarries</i>	
	<i>Timely certification of works executed</i>	
3	<i>Clarity in Specs,drawings,other docs etc</i>	
	<i>Adequate information provided on website for tender notification, parties qualified etc.</i>	
4	<i>Timely receipt of material at site for execution</i>	
	<i>Performance Guarantee/EMD released in time</i>	
5	<i>Inspection &amp; quality assurance support for timely job completion</i>	

We thank you for your time and courtesy!!

Doc. Title	GENERAL CONDITIONS OF CONTRACT - COMPOSITE WORKS	
Rev. No	0	Page 61 of 104

## ANNEXURE-J

### ACCEPTANCE FORM FOR PARTICIPATION IN REVERSE AUCTION EVENT

***(To be signed and stamped by the bidder prior to participation in the auction event)***

In a bid to make our entire procurement process more fair and transparent, TPCODL intends to use the reverse auctions through SAP-SRM tool as an integral part of the entire tendering process. All the bidders who are found as technically qualified based on the tender requirements shall be eligible to participate in the reverse auction event.

**The following terms and conditions are deemed as accepted by the bidder on participation in the bid event:**

1. TPCODL shall provide the user id and password to the authorized representative of the bidder. *(Authorization Letter in lieu of the same shall be submitted along with the signed and stamped Acceptance Form).*
2. TPCODL will make every effort to make the bid process transparent. However, the award decision by TPCODL would be final and binding on the supplier.
3. The bidder agrees to non-disclosure of trade information regarding the purchase, identity of TPCODL, bid process, bid technology, bid documentation and bid details.
4. The bidder is advised to understand the auto bid process to safeguard themselves against any possibility of non-participation in the auction event.
5. In case of bidding through Internet medium, bidders are further advised to ensure availability of the entire infrastructure as required at their end to participate in the auction event. Inability to bid due to telephone line glitch, internet response issues, software or hardware hangs, power failure or any other reason shall not be the responsibility of TPCODL.
6. In case of intranet medium, TPCODL shall provide the infrastructure to bidders. Further, TPCODL has sole discretion to extend or restart the auction event in case of any glitches in infrastructure observed which has restricted the bidders to submit the bids to ensure fair & transparent competitive bidding. In case an auction event is restarted, the best bid as already available in the system shall become the start price for the new auction.
7. In case the bidder fails to participate in the auction event due any reason whatsoever, it shall be presumed that the bidder has no further discounts to offer and the initial bid as submitted by the bidder as a part of the tender shall be considered as the bidder's final no regret offer. Any offline price bids received from a bidder in lieu of non-participation in the auction event shall be outrightly rejected by TPCODL.
8. The bidder shall be prepared with competitive price quotes on the day of the bidding event.
9. The prices as quoted by the bidder during the auction event shall be inclusive of all the applicable taxes, duties and levies and shall be FOR at TPCODL site.
10. The prices submitted by a bidder during the auction event shall be binding on the bidder.
11. No requests for time extension of the auction event shall be considered by TPCODL.
12. The original price bids of the bidders shall be reduced on pro-rata basis against each line item based on the final all inclusive prices offered during conclusion of the auction event for arriving at Contract amount.

**Signature & Seal of the Bidder**



Doc. Title	GENERAL CONDITIONS OF CONTRACT - COMPOSITE WORKS	
Rev. No	0	Page 63 of 104

send payment information)

Name of the Authorized Signatory :

Contact Person's Name :

Official Correspondence Address :

We confirm that we will bear the charges, if any, levied by our bank for the credit of NEFT/RTGS amounts in our account. Any change in above furnished information shall be informed to TPCODL well in time at our own. Further, we kept TPCODL indemnified for any loss incurred due to wrong furnishing of above information.

Thanking you,

For \_\_\_\_\_

**(Authorized Signatory)**

**(Signature with Rubber Stamp)**

**Certification from Bank:**

We confirm that we are enabled for receiving NEFT/RTGS credits and we further confirm that the account number (specify Bank a/c no.) of (Please mention here name of the account holder), the signature of the authorized signatory and the MICR and IFSC Code of our branch mentioned above are correct.

This also is certified that the above information is correct as per Bank record

**(Manager's/ Officers Signature under Bank Stamp)**

Doc. Title	GENERAL CONDITIONS OF CONTRACT - COMPOSITE WORKS	
Rev. No	0	Page 64 of 104

**ANNEXURE-L**  
**CONTRACTOR SAFETY MANAGEMENT SYSTEM**

**1. OBJECTIVE**

The objective of the Contractor Safety Management System is to lay down clear guidelines for all Business Associates (including their associates, staff and agents) which would facilitate them to observe all statutory rules and regulations, comply with applicable standards of Central Electricity Authority (Measures relating to safety and electric supply) Regulations, 2010 & (safety requirements for construction, operation and maintenance of electrical plants and electric lines) Regulations, 2011, TPCODL Safety Manual and Guidelines and thus, ensure creation of safe working environment for all stakeholders of our network.

**2. SCOPE**

All contracts (minor and major) will be subject to the provisions of this document.

**Minor Contracts:** Contracts which satisfy all the criteria listed under the head “Minor Contracts”.

**Major Contracts:** Contracts which satisfy any two or more criteria listed under the head “Major Contracts”

Criteria	Minor Contracts	Major Contracts
Value of Contract	< Rs. 1500000/- (less than Rs. Fifteen Lac)	>= Rs. 1500000/- (Equal or more than Rs. Fifteen Lac)
Period	Period less than 1 year	Any period
Working on energized electrical equipment	No	Yes
Working on height (above 1.8 Mtrs from ground)	No	Yes
Work involving construction activity	No	Yes
Working with hazardous goods or chemicals	No	Yes
Work involving danger to general public	No	Yes

**Note:** Exceptions for major and minor contract are – in house software development, supply of material or equipment but no direct or indirect installation of the same material, administration contracts (courier, water supply, printing, security, transport, etc.), minor civil work like plastering at ground level or flooring, etc. The facility management (housekeeping) contract will always be treated as a minor contract.

Doc. Title	GENERAL CONDITIONS OF CONTRACT - COMPOSITE WORKS	
Rev. No	0	Page 65 of 104

### 3. INFORMATION REQUIRED AT TIME OF VENDOR REGISTRATION OR BEFORE COMMENCEMENT OF CONTRACT

- 3.1 Business Associate is required to fill the Safety Management System Questionnaire as per *annexure 1* and submit along with the vendor registration process / bid / tender document. The filled questionnaire will be scrutinized by Engineer In-charge / indenting group and recommend suitability of the BA with respect to safety requirements. The fulfilment of statutory requirements for vendor registration pertaining to labour laws etc. shall be done by BA Cell on being referred to it.
- 3.2 Business Associate is required to take suitable risk control measures mentioned against the identified Hazards and Risk document provided for all contracts as per *annexure 2*. The primary objective of this is to evaluate the understanding of the BA towards risk mitigation and employment of safe work procedures. BA is required to conduct the Hazard identification and Risk Assessment study as per the procedure and deploy more or other measures if deemed necessary.
- 3.3 Business Associate shall comply with **Statutory Requirements related to Safety and Occupational Health** and submit the "Safety Undertaking" as per *annexure 4*.

### 4. GENERAL SAFETY CONDITIONS REQUIRED TO BE FULFILLED BY BUSINESS ASSOCIATES

The requirements of the contractor safety management system applicable to the minor or major contracts related to various groups are as following –

- 4.1 Maintenance of Distribution Network – *Annexure 3.1*
- 4.2 Distribution Projects – *Annexure 3.2*
- 4.3 EHV Projects – *Annexure 3.3*
- 4.4 Maintenance of Sub transmission network – *Annexure 3.4*
- 4.5 Civil / Generation Projects – *Annexure 3.5*
- 4.6 Meter Management Group (MMG), Revenue Recovery Group (RRG), Energy Auditing Group, AMI, MRG, etc. – *Annex3.6*
- 4.7 Maintenance and Operation of Street Light. – *Annexure 3.7*

1. *Please note that hydra cranes used by any dept should be ACE Model No. FX 150 ACE SX 150, Escorts Model No. TRX 1550 or contemporary. Use of old generation hydra cranes like ACE 14XW or ACE 12 XW, etc are prohibited.*

**(Details as per Annexure attached)**

**Note:** For minor contracts, the BA shall assign the duties of Safety Representative to the Work Supervisor. Work Supervisor will deliver all duties and responsibilities of Safety Supervisor as detailed in this document.

The Business Associate (BA) having major contract will appointing Safety supervisor, engineer / manager for the TPCODL work. The BA shall make all necessary arrangements for getting their workforce safety trained and competency checked from the concerned official of TPCODL before deployment in the field. BA Cell shall recommend the suitability after competency checked by Engineer In-charge and SAFETY group (or his representative) of TPCODL. After getting the clearance from concerned official, BA cell and receiving temporary I-card issued by TPCODL, Business Associate shall commence the working.

Safety Representative of Business Associates will formally become the nodal point for safety concerns for TPCODL. **BA shall not frequently transfer or terminate the services of any of the safety representatives appointed for TPCODL work site. BA needs to ensure**

Doc. Title	GENERAL CONDITIONS OF CONTRACT - COMPOSITE WORKS	
Rev. No	0	Page 66 of 104

**that Safety representative is available at all points of time; failing which the work being carried out in the interim (period when Safety representative is not available) shall be treated as working under improper supervision and due penal provisions shall be initiated against the BA.** BA will be required to provide all applicable infrastructure and power to ensure smooth working of the safety representative to maintain a sound safety management system. **In all contracts safety representative will not be assigned any other activity at site apart from the works related to safety management. The duties are detailed in clause 5.5 of this document.** TPCODL will be auditing the facilities provided to the BA's safety team time to time.

The Safety Representative of the BA shall be required to meet and follow the instructions of the Engineer In-charge and SAFETY Group of TPCODL. He shall be responsible for providing the MIS and/or any other relevant information, as and when desired, within the stipulated time frame as per the requirements of TPCODL. Any non-conformance to safety will lead to the negative marking or issue of safety violation challan/ tokens which shall affect the monthly evaluation and performance of BA.

All contracts where BA has to depute vehicle for their staff and equipment to move from one location to other, the BA shall ensure that vehicle complies all required statutory clearances and requirement as per The Motor Vehicle Act, 1988 as well as TPCODL Road Safety Policy and are in good & safe state of working.

## **5. QUALIFICATION AND EXPERIENCE OF THE SAFETY AND SITE PERSONNEL**

Qualification and experience required for the safety and site personnel are as following:

**5.1 Safety Supervisor:** It is mandatory that educational qualification of safety supervisor be ITI (of relevant trade) / Diploma (Any branch of engineering) and he has a working experience on electrical system / relevant field of work at least 5 yrs for ITI and 3 years for Diploma holder. Having formal experience of the safety systems will be an added advantage

**5.2 Safety Engineer:** It is mandatory that educational qualification of safety engineer be at least Diploma (relevant branch) and he has working experience on electrical system of at least 3 yrs. Having the formal experience of the safety systems will be an added advantage.

**5.3 Safety Manager:** The educational qualification of safety manager should be graduate engineer with working experience on electrical system / network of at least 3 yrs. OR Diploma in Industrial Safety with working experience of 05 years including at least 02 years on electrical network.

However, clause 5.1, 5.2 and 5.3 are not applicable for minor contracts. In such cases, BA shall assign the duties of Safety Representative to the Work Supervisor. Work Supervisor will deliver required duties of Safety Representative (as per clause 5.5) in addition to other duties without diluting the importance of safety.

**5.4 Site Skilled Personnel:** For all responsibility related to site activities and operations, the BA shall employ only qualified and skilled persons and shall comply the provisions of section 19 & 29 of Central Electricity Authority (Measures relating to safety and electric supply) Regulations, 2010. Persons holding valid approvals only by any Government approved agency or a competency assessment panel or a team set up by TPCODL



Doc. Title	GENERAL CONDITIONS OF CONTRACT - COMPOSITE WORKS	
Rev. No	0	Page 67 of 104

shall be allowed to perform the High Risk / High Hazard activities (refer page 1). The skill / qualification required for the electrician and electrical supervisor are given in *annexure 5*. The contracts related to maintenance of Distribution Network, Distribution Projects, EHV Projects, maintenance of Sub-Transmission Network, MMG & EAG, maintenance and operation of street lights, shall preferably have at least 20 per cent of ITI qualified electricians in the first year of the contract. This figure shall preferably be incremented by 15 per cent every subsequent year.

*Note: For the competency assessment may please refer the work instructions. An employee shall have to necessarily undergo the competency assessment check once in every eighteen months.*

#### 5.5 Requirements from the Safety Representative(s) of the Business Associate:

- 5.5.1 Safety training of 2 hrs/employee/month and one day of safety induction training to all new employees joining the BA will be conducted by the BA as per Safety training modules of TPCODL.
- 5.5.2 Safety Talk / tool box talk before start of shift to BA employees.
- 5.5.3 Ensuring the availability & proper usage of the standard safety equipment (PPE)
- 5.5.4 Periodic inspection of PPE to ensure their serviceability and maintaining the 10% buffer stock of standard PPEs.
- 5.5.5 Ensuring the adherence to standard operating procedures of TPCODL as mentioned in TPCODL Safety standard and O & M and concerned function's manual.
- 5.5.6 Safety inspections / audits as per the process of TPCODL
- 5.5.7 Working in close coordination SAFETY Group of TPCODL.
- 5.5.8 Reporting of unsafe acts, unsafe conditions, near miss, incident or accident to Engineer In-Charge and SAFETY Group of TPCODL immediately after its occurrence.
- 5.5.9 Regular HIRA at site and comply the control measures as stated in the detailed HIRA as per the *annexure 2*. Also deployment of JSA based checklist shall be ensured.
- 5.5.10 Ensuring compliance with safety and other laws as may be applicable and providing for safety assurance.

#### 5.6 Training and Syllabus: The BA shall not deploy any person at work place / site or send newly recruited personnel directly to concerned official for competency assessment without Safety Induction Training.

5.6.1 All new BA employees have to necessarily undergo one and half days Safety training and Competency assessment at training centre of BA cell. This training will be conducted once in a week. After the completion of Safety training & Competency assessment I-card will be issued to all competent BA employees

5.6.2 BA is expected to initially train and judge the capability of the workman at his own end before further recommending the workmen for Competency assessment. If any BA workman sent for competency assessment. In case any BA workman fails in the Competency test at concerned official, it will be deemed that BA has not imparted sufficient training at his end and actual cost of training ₹ 7500/ BA employee/ failed attempt will be recovered.

5.6.3 The workers who have imparted Safety Training and issued I-Cards of TPCODL, are not deployed at TPCODL worksites/ voluntarily left the job by workers/ used somewhere else other than TPCODL by the BA, in that case Management reserves the rights to intervene and recover the actual cost of training i.e. ₹ 7500/BA employee. (*Exempted for attrition rate of BA workers less than or equal to 10% of total workforce deployed at TPCODL*)

Doc. Title	GENERAL CONDITIONS OF CONTRACT - COMPOSITE WORKS	
Rev. No	0	Page 68 of 104

5.7 It is desired that Safety representative of the BA to impart the general safety training to each employee of duration 2 hrs per month. The training will be organized at BA level and the record to be sent to engineer in-charge and SAFETY group of TPCODL every month. Please refer schedule and syllabus in *annexure 6*.

**List of Personal Protective Equipment (PPE) and Maintenance schedule:** BA shall commence the project or any work only when the required PPE are made available to the team of employees involved in the work. Each PPE of BA shall be checked / inspected by the safety representative / supervisor at zone before the work start or as prescribed in the list. Safety representative shall regularly check the healthiness of each PPE allocated to lineman. Suitable record shall be maintained at zone. Defective PPE shall be immediately replaced or within 24 hours by the BA. In no case linemen or any other official of BA may be allowed to work with defective PPE. It is preferred that BA ensures minimum stock of each PPE at zone for immediate replacement with defective one. The PPE shall be IS / BS / CE marked and exactly as per the standard or specification mentioned in the *annexure 7*. Working without PPE / non-standard PPE shall be treated as safety violation and penalty as stated in section 6.0 of this document. If TPCODL finds that BA has not provided the adequate / appropriate PPE to their staff, TPCODL reserves the rights to stop the work and call the BA to provide appropriate PPEs at the risk. If the BA fails to provide the required PPEs at the risk then the same shall be provided by TPCODL at the actual cost of the PPE. The amount shall be charged to BA and same shall be first recovered from the current bill of BA or any future payment to be made to BA. In the event of any balance amount still left for recovery, the same shall be adjusted against retention amount or by invoking bank guarantee submitted by BA.

**5.8 Safety Audit / Inspection & HIRA:** The BA shall get the required safety inspection / audit conducted by his technical team comprising of safety representative as per the *annexure 8*. The safety representative will be required to conduct the HIRA (Hazard Identification and Risk Assessment) *as per annexure 2* of the process and work undertaken at least two times in a year or every time if a new process / activity / machine is introduced or whenever an accident take place. The risk identified to be addressed suitably with –

- Engineering Control
- Management Control, and
- Personal Protective Equipment.

The safety representative of BA shall inform and educate for the identified risk and hazard control methods to employees, supervisor and engineer as well as the engineer in-charge and SAFETY group of TPCODL.

**5.9 Safety Performance and Safety MIS:** The BA shall maintain good practice of safety all through the contract duration. Safety shall always be of paramount importance during the contract period. Safety performance will be monitored on yearly basis throughout the period and no relaxation will be given for bad performance. BA with good track record and excellent performance will be rewarded suitably as per clause 6.0 of this document. The BA has to provide monthly “Performance Report – Safety” to engineer in-charge and SAFETY group TPCODL this shall be part of monthly bill along with training details. Performa of the report is enclosed as *annexure 9*.

**5.10 Pre – Employment Medical Check-up and Fitness of employees engaged for the critical works:** The BA shall submit the health fitness certificate for all those workers involved in climbing the pole or working at height for following diseases:

5.10.2 Epilepsy

Doc. Title	GENERAL CONDITIONS OF CONTRACT - COMPOSITE WORKS	
Rev. No	0	Page 69 of 104

- 5.10.3 Colour blindness
- 5.10.4 Deafness
- 5.10.5 Vertigo & height phobia

Every year BA will give an undertaking stating that all the employees are fit to work and have not developed aforesaid diseases. The Record of such medical check-ups shall be submitted to BA Cell before issue of temporary identity card. The records shall be maintained at BA Cell. All such medical check-ups shall be repeated once in a year for all workers involved in climbing the pole or working on electrical network.

## 6. REWARD AND PUNITIVE MEASURES

**6.1** To support the enforcement of good SHE & DM practices by the Business Associate and to eliminate repeated or continuing safety violations, use of appropriate reward and punitive measures shall be made. Each unsafe act or violation of the safety guidelines as described in the Safety Manual of the TPCODL will be audit criteria of this system. Broadly the measures identified are following:

- 6.1.1 Working without PPE/ Safety Gadgets
- 6.1.2 Working without proper tools and tackles, barricading, Poor condition of Crane / Hydra / Vehicle, using without certification / Licence, Incompetent driver/ Helper
- 6.1.3 Working without creation of effective safety zone
- 6.1.4 Improper Supervision at worksite, Lineman/ Supervisor working without competency
- 6.1.5 Working without adherence to PTW process or authorization/ not adherence to SOPs / W.I. of TPCODL.
- 6.1.6 Improper Working at height equal to or above 1.8 mtrs without taking proper fall protection measures/ Poor condition of Ladder

### 6.2 Measures of Reward and Punitive Measures

The Engineer In-Charge, NSO, SC, ASOs, CSI / SIs and SHE &DM group will conduct the surprise audits of the work / project and if any non-conformance is found the same will be booked and entered in the format "Safety Violation Record" *annexure 10*. The flow of the information is given below:

Safety Violation Escalation & Monitoring process	
Action	Responsibility
Safety Violation form has been filled and counter foil sent to SAFETY team for information. The main form is to be given to BA supervisor / Engineer in-charge. <i>(Automatically generated if Site audit done through Mobile App.)</i>	Engineer In-charge/ NSO / SC / SAFETY Group /CSI/ ASO/ Any authorised TPCODL official.
↓	
Entry of the violation in the master record and sending the information to concerned Manager, HoG, HoD, Head and Chief (O &S). <i>(Automatically generated if Site audit done through Mobile App.)</i>	SAFETY Group
↓	
Forwarding the information Centralized Account Payable (CAPS) for amount deduction from the current bill of the BA,	Engineer In-charge

<i>if any.</i>	
↓	
HoG (Safety – II) & HoG (Safety & Quality – Commercial) and CAPS to generate the MIS of the violations and the amount deducted.	SAFETY Group
↓	
The pool of the amount generated after the deduction to be utilized in safety welfare of BA employees.	SAFETY Group with approval of CFO/Chief (O & S) /CEO&MD

The safety violations have been rated from 1 to 5 (figure 6.3) as per the gravity of the violation. If the same violation is repeated it may escalate into a higher penalty. If a particular Business Associate employee violates safety norms three times, he shall not be allowed to work in TPCODL for a period of one year from the date of the 3<sup>rd</sup> violation.

### 6.3 Safety Violation Escalation Matrix

#### 6.3.1

Consequence of Safety Violation Observed (Not related to Incident/ Accident)		Violation				Subsequent Violations
S.No.	Safety Violation	1st	2nd	3rd	4th	
1	Working without PPE (Helmet/Gloves/Safety Harness/ Safety Shoes etc.)	A	B	C	D	Will attract the same penalty as applicable in the 4th violation.
2	Improper Working at Height	A	B	C	D	
3	Working without proper tools and tackles	A	B	C	D	
4	Poor condition of Crane/Hydra/ Vehicle/Incompetent driver/ Helper	A	B	C	D	
5	Violation of SOP/ WI	B	C	D	E	
6	Working without adherence to PTW process or authorization/ Safety Zone	C	D	E		
<b>Legend</b>		<b>Action to be taken</b>	<b>Responsibility</b>	<b>Penalty Amount (in Rs.)</b>		The number of violations are to be calculated cumulatively over the contract period and not on monthly basis.
A	Warning letter	Engineer Incharge	Nil			
B	Levy of Penalty	Engineer Incharge	2,000			
C	Memo to BA & Levy of Penalty	Head of Group	4,000			
D	Memo to BA & Levy of Penalty	Head of Department	10,000			
E	Memo to BA, Levy of Penalty and termination of Contract	Head of Department	1,00,000			

Figure 6.3 (1a)-Penalty Matrix for Safety violation (Applicable for Minor Contracts)

Consequence of Safety Violation Observed (Not related to Incident/ Accident)		Violation				Subsequent Violations
S.No.	Safety Violation	1st	2nd	3rd	4th	
1	Working without PPE (Helmet/Gloves/Safety Harness/ Safety Shoes etc.)	B	C	D	D	Will attract the same penalty as applicable in the 4th violation.
2	Improper Working at Height	B	C	D	D	
3	Working without proper tools and tackles	A	B	C	D	
4	Poor condition of Crane/Hydra/ Vehicle/Incompetent driver/ Helper	B	C	D	E	
5	Violation of SOP/ WI	C	D	E		
6	Working without adherence to PTW process or authorization/ Safety Zone	C	D	E		
<b>Legend</b>		<b>Action to be taken</b>	<b>Responsibility</b>	<b>Penalty Amount (in Rs.)</b>		The number of violations are to be calculated cumulatively over the contract period and not on monthly basis.
A	Levy of Penalty	Engineer Incharge	5,000			
B	Memo to BA & Levy of Penalty	Engineer Incharge	10,000			
C	Memo to BA & Levy of Penalty	Head of Group	25,000			
D	Memo to BA & Levy of Penalty	Head of Department	50,000			
E	Memo to BA, Levy of Penalty and termination of Contract	Head of Department	1,00,000			

Figure 6.3 (1b)-Penalty Matrix for Safety violation (Applicable for Major Contracts)

Doc. Title	GENERAL CONDITIONS OF CONTRACT - COMPOSITE WORKS	
Rev. No	0	Page 71 of 104

Once the BA reaches the “BLACK” (color – “5”) category, i.e. highest level of safety violation, “Termination” notice to BA will be issued from the office of the Head of Department (equivalent to Addl GM/ GM/ Sr. GM level) and further, *if required*, continuation / extension of contract will only be initiated by Functional Head of the department (equivalent to Sr. GM / VP level) and approved by CEO & MD. Till the extension, the contract will remain suspended.

TPCODL encourages the reportage of the safety violation during the contract work by BA. Any TPCODL employee can register a safety violation against the BA in the “Safety Violation Form” *annexure 10*. Initially the observer has to fill the form and handover the counterfoil (lower portion) of the document to the supervisor of the BA, inform the site engineer of TPCODL and send the top portion of the Safety Violation Form to SAFETY group for the further necessary action against the BA. **The cumulative nos. of Safety Violations pertaining to any particular BA shall be calculated on yearly basis.**

Safety violations resulting in incident / accident will be treated as per gravity of the injury / fatality and its impact as well as type i.e. minor or Major. Consequences of incident / accident are shown in the matrix (figure 6.3(2) for major and 6.3(3) for minor) below. In case of any accident, findings and recommendations of Accident Enquiry Committee will be final and binding and will supersede the arbitration clause of GCC.

Consequence Of an Incident / Accident (In case of <b>MAJOR</b> contract)		Incident / Accident				Action Required
Sl. No	Type of the injury	1st	2nd	3rd	4th	
1	Slight injury (First Aid Case)	<b>F</b> (Strengthening of process through continuous improvement in the work procedure)				Take risk reduction measures
2	Minor injury (No or Hospitalization less than 48 Hrs)	<b>F</b>	<b>G</b>	<b>G</b>	<b>H</b>	
3	Major injury (Bone injury or burn or Hospitalization more than 48 Hrs)	<b>G</b>	<b>G</b>	<b>H</b>	<b>I</b>	
4	Single fatality	<b>J</b>	<b>K</b>			Intolerable
5	Multiple fatalities (Two or more fatalities during one event)	<b>K</b>				
Legend	Action to be taken	Responsibility		Penalty (in Rs.)	The number of violations are to be calculated cumulatively over the contract period and not on monthly basis.	
<b>F</b>	Memo to BA and levy of penalty	Engineer Incharge		5,000/-		
<b>G</b>	Memo to BA and levy of penalty	Head of Group		20,000/-		
<b>H</b>	Memo to BA and levy of penalty	Head of Group		50,000/-		
<b>I</b>	Memo to BA and levy of penalty	Head of Department		2,00,000/-		
<b>J</b>	Memo to BA and levy of penalty	Head of Department		5,00,000/-		
<b>K</b>	Memo to BA, levy of penalty, termination of contract and black listing of BA	Functional Head		10,00,000/-		

Figure 6.3 (2) - Penalty Matrix for Incident / Accident in Major Contracts

(For example: In major contracts, if there is first incidence of major injury say bone injury (Cat. 3) where worker was hospitalized for more than 48 hrs then a penalty of amount Rs.20000/- will be deducted from the current bill produced for the payment. This penalty will be similar for first two incidents. However, it will increment to next higher category i.e. Rs. 50,000/- on subsequent incidents as per the above matrix)

Doc. Title	GENERAL CONDITIONS OF CONTRACT - COMPOSITE WORKS	
Rev. No	0	Page 72 of 104

Consequence Of an Incident / Accident (In case of <b>MINOR</b> contract)		Incident / Accident				Action Required
Sl. No	Type of the injury	1st	2nd	3rd	4th	
1	Slight injury (First Aid Case)	<b>L</b> <small>(Strengthening of process through continuous improvement in the work procedure)</small>				Take risk reduction measures
2	Minor injury (No or Hospitalization less than 48 Hrs)	<b>L</b>	<b>M</b>	<b>M</b>	<b>N</b>	
3	Major injury (Bone injury or burn or Hospitalization more than 48 Hrs)	<b>M</b>	<b>M</b>	<b>N</b>	<b>O</b>	
4	Single fatality	<b>P</b>	<b>Q</b>			Intolerable
5	Multiple fatalities (Two or more fatalities during one event)	<b>Q</b>				
Legend	Action to be taken	Responsibility	Penalty (in Rs.)	The number of violations are to be calculated cumulatively over the contract period and not on monthly basis.		
<b>L</b>	Memo to BA and levy of penalty	Engineer Incharge	5,000/-			
<b>M</b>	Memo to BA and levy of penalty	Engineer Incharge	10,000/-			
<b>N</b>	Memo to BA and levy of penalty	Head of Group	25,000/-			
<b>O</b>	Memo to BA and levy of penalty	Head of Department	1,00,000/-			
<b>P</b>	Memo to BA and levy of penalty	Head of Department	3,00,000/-			
<b>Q</b>	Memo to BA, levy of penalty, termination of contract and black listing of the BA	Functional Head	5,00,000/-			
<b>Figure 6.3 (3) - Penalty Matrix for Incident / Accident in Minor Contracts</b>						

(For example: In minor contracts, if a worker meets with a non-fatal accident say bone injury (Cat. 3) where he was hospitalized for more than 48 hrs then a penalty of amount Rs. 10,000/-, will be charged from the current bill produced for the payment. This penalty will be similar for first two incidents. However, it will increment to next higher category i.e. Rs. 25,000/- on subsequent incidents as per the above matrix.)

In case of single or multiple fatalities described under legends J&K of 6.3(2) and P&Q of 6.3(3), the concerned BA may be debarred from extension of contract or participate in new contract. In such event the approval of Chief (O & S) will be necessary for extension or award of new contract to concerned BA.

### 6.3.2 COMPENSATION FOR BA PERSONNEL

In the event of any untoward incident/ accident, the Business Associate shall ensure prompt medical assistance such as treatment, sickness benefit, etc. is provided to the victim(s) as per the Employees' Compensation Act, 1923 or Employees' State Insurance Act, 1948, as applicable. Also, the BA will be required to take adequate measures for compensating the victim(s) or his/her/their kin as follows:

#### I. For Death or Permanent / Total Disablement

The BA shall take an insurance coverage of at least Rs. 10 lakhs for each engaged employee, to cover any incidence of Death or Permanent / Total Disablement (Permanent/Total Disability shall be considered as defined under Employees' Compensation Act, 1923). In the event of any such unfortunate incident, the BA would ensure that adequate compensation is paid immediately to the family of the victim(s) from his own resources. This compensation shall be covered under the insurance policy subscribed by the BA mentioned earlier and the arrangement should be such that it would get reimbursed to the BA by the insurance agency subsequently.

Doc. Title	GENERAL CONDITIONS OF CONTRACT - COMPOSITE WORKS	
Rev. No	0	Page 73 of 104

## II. For Permanent Partial Disablement and Temporary Total Disablement

The compensation in this case will be as per provisions of the Employees' Compensation Act, 1923 or Employees' State Insurance Act, 1948, as applicable.

Accordingly, the BA shall obtain a suitable Insurance Policy on award of Contract and submit documentary evidence of the policy to the BA Cell before commencement of work. The BA shall ensure that the Insurance policy is active at all times and all employees are covered in all respects till the conclusion of contract period or till working with TPCODL. The BA shall submit a copy of the policy after periodic renewals to the BA Cell.

However, on occurrence of such unfortunate incident, if it is found that the victim(s) is/are not covered under any insurance policy, the BA shall be liable to pay the entire sum of Rs. 10 lakhs from his own resources.

Further, in case of an accident resulting in Death or Permanent / Total Disablement while on duty, the appointed BA Nodal Officer will ensure that the BA complies with all statutory provisions and benefits i.e. PF, Compensation, Gratuity etc., and that all these are made available to the employees' nominee(s) as per the stipulated timelines.

**6.3.3** TPCODL rewards the BA with good track record of safety management. It is proposed that BA complying with Contractors Safety Management, Safety Manual and Safety process will be rewarded suitably as per the procedure, rule and regulations of the TPCODL. In any case major accident is reported during an assessment period BA will not be eligible for this reward scheme. Assessment of contracts will be once in year. Generally the assessment cycle is calendar year and guidelines will be declared time to time.

### Abbreviations Used in the Document

TPCODL	TP Central Odisha Distribution Limited
BA	Business Associate
HIRA	Hazard Identification & Risk Assessment
JSA	Job Safety Analysis
EHV	Extra High Voltage
SAFETY	Safety, Occupation Health, Environment & Disaster Management
MMG	Meter Management Group
EAG	Energy Audit Group
PPE	Personal Protective Equipment
SOP	Standard Operating Procedures
CSI/SI	Circle Safety In-charge / Safety In-charge
ASO	Area Safety Officer
NSO	Nodal Safety Officer
SC	Safety Coordinator
HoG / HoD	Head of Group / Head of Department
AGM / GM / VP	Assistant General Manager / General Manager / Vice President

Doc. Title	GENERAL CONDITIONS OF CONTRACT - COMPOSITE WORKS	
Rev. No	0	Page 74 of 104

CFO / Chief (O & S)/ CEO & MD	Chief Finance Officer / Chief (Operating & Safety) / Chief Executive Officer & Managing Director
COS	Corporate Operation Services
CAP	Centralized Account Payable System
PTW	Permit To Work
GCC	General Conditions of Contract.

- END -

GENERAL CONDITIONS OF CONTRACT



Doc. Title	GENERAL CONDITIONS OF CONTRACT - COMPOSITE WORKS	
Rev. No	0	Page 75 of 104

**Annexure 1 (Refer Para 3.1)**

***Business Associate Safety Management System Questionnaire***

Certification					
The information provided in this questionnaire is a summary of the company's occupational health and safety management system.					
Company Name:					
Turnover and experience:		Name of top officer:			
Date:		Position			
Contract Details					
Contract Name			Contract Number:		
Business Associates Safety Management System Questionnaire		Marks	Yes	No	Score achieved
<i>Safety Policy and Management</i>					
- <b>Is there a written company Safety policy?</b>		1			
- If yes provide a copy of the policy, if No please refer Note 1.					
- <b>Does the company have an Safety Management system</b>		1			
- If yes provide details, if No please refer Note 1.					
- <b>Is there a company Safety Management System manual or plan?</b>		2			
- If yes provide a copy of the content page(s), if No please refer Note 1.					
- <b>Are Safety and occupational health responsibilities clearly identified for all levels of Management and staff?</b>		2			
- If yes provide details, if No please refer Note 1.					
<i>Safe Work Practices and Procedures</i>					
- <b>Has the company prepared safe operating procedures or specific safety instructions relevant to its operations and relevant work as per contract?</b>		1			
- If yes provide a summary listing of procedures or instructions, if No please refer Note 2.					

Certification				
- Comments				
- <b>Is there a register of injury or accident?</b> - If yes provide a copy (format)	1			
- <b>Is there a documented incident or accident investigation procedure?</b>  - If yes provide a copy of a standard incident report form, if No please refer Note 2.  - Comments	1			
<i>Safety Training</i>				
- <b>Describe how occupational health and safety training is conducted in your company</b>  If No please refer Note 1.	2			
- <b>Is a record maintained of all training and induction programs undertaken for employees in your company?</b>  - If yes provide examples of safety training records, if No please refer Note 2.	1			
- <b>Are regular safety inspections / audits are undertaken at worksites?</b>  -If yes provide details (formats), if No please refer Note 3.	1			
- <b>Is there a procedure by which employees can report hazards at workplaces?</b>  - If yes provide details if No please refer Note 1.	1			
<i>Safety Monitoring</i>				
- <b>Is there an officer / supervisor responsible for monitoring workplace / worksite safety?</b>	1			

Doc. Title	GENERAL CONDITIONS OF CONTRACT - COMPOSITE WORKS		
Rev. No	0	Page 77 of 104	

Certification				
- If yes provide details				
<i>Safety Performance Monitoring</i>				
- <b>Are employees regularly provided with information on company health and safety performance?</b>	1			
- If yes provide details				
- <b>Has the company ever been convicted of an occupational health and safety offence?</b>	NO Marks (Negative mark ONE for each case)			
- If yes provide details				
- Has there been any major accident of employee at TPCODL site in past	NO Marks (Negative mark ONE for each case)			
- Has there been any fatal accident of employee at TPCODL site in past. - (Note: Bid evaluation committee has to take cognizance of the incident and shall evaluate the bid only after formal approval of competent authority i.e. CTO. - In case of yes please refer Note 4.	NO Mark (Negative mark FIVE for each case)			
Minimum of 75% marks is required for qualification.		Total Marks achieved		
<i>Company Reference</i>				
1. Name of company 2. Name of company				

**Note**

1: If company does not have formal procedure on Safety Management System than vendor may submit proposed Safety road map along with safety action plan and brief safety policy on his letter head signed by head of the organization.

2: The vendor may submit the same in the Safety Action Plan.

3: The vendor may utilize the same format of TPCODL or on request SAFETY group will assist the vendor in developing the audit system. For other points also vendor may take the assistance of SAFETY group for development of Safety management system.

Doc. Title	GENERAL CONDITIONS OF CONTRACT - COMPOSITE WORKS	
Rev. No	0	Page 78 of 104

4: The vendor may submit the Safety Improvement Plan and Safety Action Plan for his employees based on following points.

- i. Action plan for enhancing safety awareness
- ii. Action plan for safety training of employee
- iii. Action plan for increasing safety audit in field
- iv. Action plan for provision and utilization of safety PPE.
- v. Action plan for fatality reduction.
- vi. Action plan for enhanced supervision at site
- vii. Action plan for making employee more responsible and accountable for safety.
- viii. Action plan for availability and utilization of all required tool and equipment.
- ix. Safety Improvement done in last two years, specially highlighting those which have been taken after the fatal accident along with results.
- x. Safety initiatives planed or started recently.
- xi. Any other point.

Based on above points and documentary evidences vendor will be required to submit a detailed report in support of his bid. The bid evaluation committee and competent authority will scrutinize the facts and the evidence submitted. If found satisfactory competent authority i.e. CTO may accord his approval for bid opening otherwise his tender shall be disqualified.

Doc. Title	GENERAL CONDITIONS OF CONTRACT - COMPOSITE WORKS	
Rev. No	0	Page 79 of 104

**Annexure 2 (Refer Para 3.2 and 5.8)**

***Risk Assessment Form***

Business Associate:
Scope of the work:
BA's Representative:
Telephone:
Signature:
Date:

Specific Task/Activity	Potential Hazards/Consequences	Class of Risk	Control Measures
Working at Height	Fall from height	2	<ol style="list-style-type: none"> <li>1. Mandatory usage of JSA checklist prior to start of work</li> <li>2. Use appropriate ladder</li> <li>3. Use full body safety harness having double lanyard.</li> <li>4. Use Electrical Safety Shoes if working on electrical network otherwise use safety shoes.</li> <li>5. Use Safety helmet.</li> <li>6. Use PPE as per the annexure 7 of this CSM document</li> <li>7. Refer Work instruction related to Working at Height for other details</li> <li>8. Use of metal scaffold to be ensured in height work (cup lock type)</li> <li>9. Deploy competent workforce who are medically fit</li> </ol>

GENERAL CONDITIONS OF CONTRACT - COMPOSITE WORKS

Specific Task/Activity	Potential Hazards/Consequences	Class of Risk	Control Measures
Working on electrical equipment / network	Electric flash / electrocution	3	<ol style="list-style-type: none"> <li>1. Mandatory usage of JSA checklist prior to start of work</li> <li>2. Use Electrical Safety Shoes while working on electrical network.</li> <li>3. Use Electrical Safety gloves of appropriate voltage rating.</li> <li>4. Use face shield / visor attached with helmet.</li> <li>5. Use Safety helmet.</li> <li>6. Use PPE as per the annexure 7 of this CSM document</li> <li>7. Mandatory usage of Insulated tools &amp; tackles on electrical system</li> <li>8. Mandatory compliance for Lock Out &amp; Tag out system. Refer Work instruction related to Working on electrical equipment / network for other details</li> </ol>
Excavation / Civil work	Collapse of soil, Fall in excavated pit leading to Injury	2	<ol style="list-style-type: none"> <li>1. Use safety shoes.</li> <li>2. Use Safety helmet.</li> <li>3. Use PPE as per the annexure 7 of this CSM document</li> <li>4. Hard Barricading of the worksite.</li> <li>5. Refer Work instruction related to excavation / civil work for other details</li> </ol>
Material lifting & Mechanical Erection work	Fall of material/object, Topple of crane,	2	<ol style="list-style-type: none"> <li>1. Mandatory compliance of crane checklist</li> <li>2. Visual condition check of lifting tools and tackles such as wire rope sling, belt sling, chain, pulley block, D-shackles, etc. shall be ensured.</li> <li>3. The operator's physical fitness and alertness should be judged by sup. / EIC.</li> <li>4. Use PPE as per the annexure 7 of this CSM document</li> <li>5. Refer Work instruction related to Material lifting &amp; Mechanical Erection work</li> </ol>
Road Safety	Road Accidents	3	<ol style="list-style-type: none"> <li>1. Mandatory compliance of TPCODL Road Safety policy W07(COR-P-12)</li> </ol>

Doc. Title	GENERAL CONDITIONS OF CONTRACT - COMPOSITE WORKS	
Rev. No	0	Page 81 of 104

Specific Task/Activity	Potential Hazards/Consequences	Class of Risk	Control Measures
------------------------	--------------------------------	---------------	------------------

*Note: This information for the general indication purpose. The detailed risk assessment shall be conducted before start of the work by the authorized representative of the BA. The report of same shall be submitted to engineer in-charge along with annexure 4 of the CSM document.*

### Guidelines for filling the Risk Assessment Form

- *Specific Task/Activity* - The documentation of each major task associated with the contract.
- *Potential Hazards* - The identification of hazards associated with each activity or task to be carried out.
- *Class of Risk* - Each hazard should be evaluated as a level of risk, described as Risk Class 1, 2 or 3 defined above.
- *Control Measure* - The identification and documentation of actions required to eliminate or reduce the hazards that could lead to accident or injury.

Hazard / Risks shall be classified according to the following schedule:

- Class 1: Potential to cause injury treatable with first aid
- Class 2: Potential to cause death or permanent injury
- Class 3: Potential to cause more than one or more lost time injuries.

Doc. Title	GENERAL CONDITIONS OF CONTRACT - COMPOSITE WORKS	
Rev. No	0	Page 82 of 104

### Annexure 3.1 (Refer Para 4.0)

#### General Safety Conditions for the Maintenance of Distribution Network Contracts:

A BA awarded a contract (O&M) work of maintenance of distribution network will be required to fulfil the following conditions:

- BA shall provide Safety Policy and safety objectives of their company.
- BA shall comply with all statutory requirements like: applicable acts, regulations, codes of practice, OHSAS Standards, etc.
- BA shall provide the filled safety management questionnaire as per Annexure 1
- BA shall conduct a job risk assessment and provide information as per Annexure 2
- BA shall abide by Safety manuals, guidelines of TPCODL.
- BA shall provide its organisation structure & responsibilities in terms of Safety Management to TPCODL.
- BA shall document the work practices and procedures in terms of Safety Management.
- BA shall ensure safety training and induction program for the employees
- BA shall conduct safety audits & inspections as per TPCODL procedures provided by SAFETY group.
- BA shall provide and ensure the proper usage of the safety equipment (PPE) as per the TPCODL approved list in *annexure 7*.
- BA shall ensure periodic inspection of PPE to ensure its serviceability as per the specification given by TPCODL.
- BA shall ensure the adherence to standard operating procedures or guidelines laid down by TPCODL.
- BA shall ensure reporting of any unsafe act, unsafe conditions, near miss, incident or accident to engineer in-charge and SAFETY team of TPCODL.
- BA shall provide safety performance and Safety MIS (*annexure 9*) to engineer in-charge and SAFETY group periodically. Based on any non-confirmation to the safety procedures and guidelines, BA is liable to be negatively marked for his performance and suitable penalty will be imposed.
- BA shall ensure to depute a Safety Supervisor for managing a complete safety management system in a district. In case the BA has been awarded work in more than one district, then the following safety structure will be adopted.





Doc. Title	GENERAL CONDITIONS OF CONTRACT - COMPOSITE WORKS	
Rev. No	0	Page 83 of 104

**Annexure 3.2 (Refer Para 4.0)**

**General Safety Conditions for the Distribution Projects Major Contracts:**

A BA awarded a major contract work of TS&P in area of a circle will be required to fulfil the following conditions:

- BA shall provide Safety Policy and safety objectives of their company.
- BA shall comply with all statutory requirements like: applicable acts, regulations, codes of practice, OHSAS Standards, etc.
- BA shall provide the filled safety management questionnaire as per Annexure 1.
- BA shall conduct a job risk assessment and provide information as per Annexure 2
- BA shall abide by Safety manuals, guidelines of TPCODL.
- BA shall provide its organisation structure & responsibilities in terms of Safety Management to TPCODL.
- BA shall document the work practices and procedures in terms of Safety Management.
- BA shall ensure safety training and induction program for the employees
- BA shall conduct safety audits & inspections as per TPCODL procedures provided by SAFETY group.
- BA shall provide and ensure the proper usage of the safety equipment (PPE) as per the TPCODL approved list in annexure 7.
- BA shall ensure periodic inspection of PPE to ensure its serviceability as per the specification given by TPCODL.
- BA shall ensure the adherence to standard operating procedures or guidelines laid down by TPCODL.
- BA shall ensure reporting of any unsafe act, unsafe conditions, near miss, incident or accident to engineer in-charge and SAFETY team of TPCODL.
- BA shall provide safety performance and Safety MIS (*annexure 9*) to engineer in-charge and SAFETY group periodically. Based on any non-confirmation to the safety procedures and guidelines, BA is liable to be negatively marked for his performance and suitable penalty will be imposed.
- BA shall ensure to depute a Safety Supervisor for managing a complete safety management system in the area. In case the BA has been awarded work in more than one circle, then the following safety structure will be adopted.

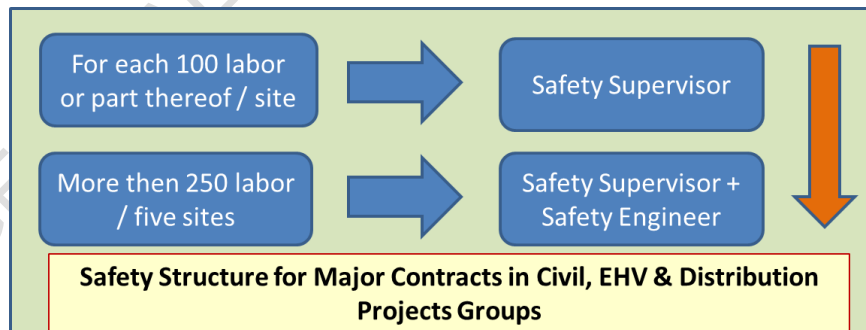

Doc. Title	GENERAL CONDITIONS OF CONTRACT - COMPOSITE WORKS	
Rev. No	0	Page 84 of 104

### **Annexure 3.3 (Refer Para 4.0)**

#### **General Safety Conditions for the major EHV Projects Contracts:**

A BA awarded a major contract work of EHV projects will be required to fulfil the following conditions:

- BA shall provide Safety Policy and safety objectives of their company.
- BA shall comply with all statutory requirements like: applicable acts, regulations, codes of practice, OHSAS Standards, etc.
- BA shall provide the filled safety management questionnaire as per Annexure 1
- BA shall conduct a job risk assessment and provide information as per Annexure 2
- BA shall abide by Safety manuals, guidelines of TPCODL.
- BA shall provide its organisation structure & responsibilities in terms of Safety Management to TPCODL.
- BA shall document the work practices and procedures in terms of Safety Management.
- BA shall ensure safety training and induction program for the employees
- BA shall conduct safety audits & inspections as per TPCODL procedures provided by SAFETY group.
- BA shall provide and ensure the proper usage of the safety equipment (PPE) as per the TPCODL approved list in annexure 7.
- BA shall ensure periodic inspection of PPE to ensure its serviceability as per the specification given by TPCODL.
- BA shall ensure the adherence to standard operating procedures or guidelines laid down by TPCODL.
- BA shall ensure reporting of any unsafe act, unsafe conditions, near miss, incident or accident to engineer in-charge and SAFETY team of TPCODL.
- BA shall provide safety performance and Safety MIS (*annexure 9*) to engineer in-charge and SAFETY group periodically. Based on any non-confirmation to the safety procedures and guidelines, BA is liable to be negatively marked for his performance and suitable penalty will be imposed.
- BA shall ensure to depute a Safety Supervisor for managing a complete safety management system in the area. In case the BA has been awarded work in more than one circle, then the following safety structure will be adopted.
- BA shall refer Construction Safety Manual in TPCODL Safety Manual for details.

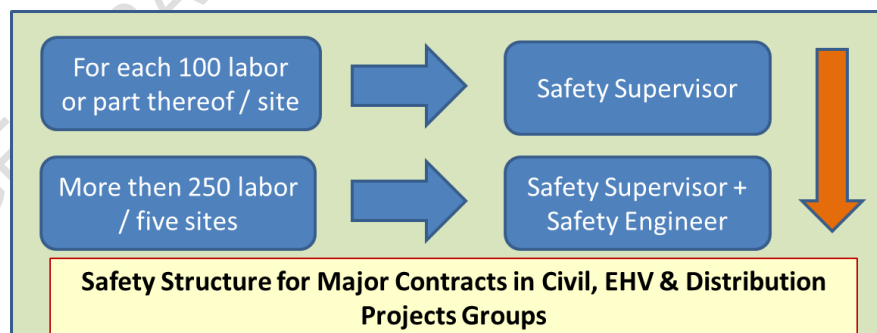

Doc. Title	GENERAL CONDITIONS OF CONTRACT - COMPOSITE WORKS	
Rev. No	0	Page 85 of 104

### Annexure 3.4 (Refer Para 4.0)

#### General Safety Conditions for the Maintenance of Sub – Transmission Network Contracts:

A BA awarded a major contract work of maintenance of sub – transmission network in area of a power system will be required to fulfil the following conditions:

- BA shall provide Safety Policy and safety objectives of their company.
- BA shall comply with all statutory requirements like: applicable acts, regulations, codes of practice, OHSAS Standards, etc.
- BA shall provide the filled safety management questionnaire as per Annexure 1
- BA shall conduct a job risk assessment and provide information as per Annexure 2
- BA shall abide by Safety manuals, guidelines of TPCODL.
- BA shall provide its organisation structure & responsibilities in terms of Safety Management to TPCODL.
- BA shall document the work practices and procedures in terms of Safety Management.
- BA shall ensure safety training and induction program for the employees
- BA shall conduct safety audits & inspections as per TPCODL procedures provided by SAFETY group.
- BA shall provide and ensure the proper usage of the safety equipment (PPE) as per the TPCODL approved list in annexure 7.
- BA shall ensure periodic inspection of PPE to ensure its serviceability as per the specification given by TPCODL.
- BA shall ensure the adherence to standard operating procedures or guidelines laid down by TPCODL.
- BA shall ensure reporting of any unsafe act, unsafe conditions, near miss, incident or accident to engineer in-charge and SAFETY team of TPCODL.
- BA shall provide safety performance and Safety MIS (*annexure 9*) to engineer in-charge and SAFETY group periodically. Based on any non-confirmation to the safety procedures and guidelines, BA is liable to be negatively marked for his performance and suitable penalty will be imposed.
- BA shall ensure to depute a Safety Coordinator for managing a complete safety management system in the area. In case the BA has been awarded work in more than one area power system, then the following safety structure will be adopted.



Doc. Title	GENERAL CONDITIONS OF CONTRACT - COMPOSITE WORKS	
Rev. No	0	Page 86 of 104

### Annexure 3.5 (Refer Para 4.0)

#### **General Safety Conditions for the major contract work in Civil / Generation Projects:**

A BA awarded a major contract work of / in civil or Generation project will be required to fulfil the following safety conditions:

- BA shall provide Safety Policy and safety objectives of their company.
- BA shall comply with all statutory requirements like: applicable acts, regulations, codes of practice, OHSAS Standards, etc.
- BA shall provide the filled safety management questionnaire as per Annexure 1
- BA shall conduct a job risk assessment and provide information as per Annexure 2
- BA shall abide by Safety manuals, guidelines of TPCODL.
- BA shall provide its organisation structure & responsibilities in terms of Safety Management to TPCODL.
- BA shall document the work practices and procedures in terms of Safety Management.
- BA shall ensure safety training and induction program for the employees
- BA shall conduct safety audits & inspections as per TPCODL procedures provided by SAFETY group.
- BA shall provide and ensure the proper usage of the safety equipment (PPE) as per the TPCODL approved list in annexure 7.
- BA shall ensure periodic inspection of PPE to ensure its serviceability as per the specification given by TPCODL.
- BA shall ensure the adherence to standard operating procedures or guidelines laid down by TPCODL.
- BA shall ensure reporting of any unsafe act, unsafe conditions, near miss, incident or accident to engineer in-charge and SAFETY team of TPCODL.
- BA shall provide safety performance and Safety MIS (*annexure 9*) to engineer in-charge and SAFETY group periodically. Based on any non-confirmation to the safety procedures and guidelines, BA is liable to be negatively marked for his performance and suitable penalty will be imposed.
- BA shall ensure to depute a Safety Supervisor (for workforce upto 100 at site) / a safety engineer (for workforce upto 250 at site) / safety manager (for more than two safety engineers) for managing a complete safety management system at the project site. In case the BA has been awarded more than one major contracts, then the following safety structure will be adopted.
- BA shall refer Construction Safety Manual in TPCODL Safety Manual for details.



Doc. Title	GENERAL CONDITIONS OF CONTRACT - COMPOSITE WORKS	
Rev. No	0	Page 87 of 104

**Annexure 3.6 (Refer Para 4.0)**

**General Safety Conditions for the major contract work in Commercial Department like - MMG, RRG, EAG, etc.:**

A BA awarded a major contract work in meter management group & energy auditing group will be required to fulfil the following safety conditions:

- BA shall provide Safety Policy and safety objectives of their company.
- BA shall comply with all statutory requirements like: applicable acts, regulations, codes of practice, OHSAS Standards, etc.
- BA shall provide the filled safety management questionnaire as per Annexure 1
- BA shall conduct a job risk assessment and provide information as per Annexure 2
- BA shall abide by Safety manuals, guidelines of TPCODL.
- BA shall provide its organisation structure & responsibilities in terms of Safety Management to TPCODL.
- BA shall document the work practices and procedures in terms of Safety Management.
- BA shall ensure safety training and induction program for the employees
- BA shall conduct safety audits & inspections as per TPCODL procedures provided by SAFETY group.
- BA shall provide and ensure the proper usage of the safety equipment (PPE) as per the TPCODL approved list in annexure 7.
- BA shall ensure periodic inspection of PPE to ensure its serviceability as per the specification given by TPCODL.
- BA shall ensure the adherence to standard operating procedures or guidelines laid down by TPCODL.
- BA shall ensure reporting of any unsafe act, unsafe conditions, near miss, incident or accident to engineer in-charge and SAFETY team of TPCODL.
- BA shall provide safety performance and Safety MIS (*annexure 9*) to engineer in-charge and SAFETY group periodically. Based on any non-confirmation to the safety procedures and guidelines, BA is liable to be negatively marked for his performance and suitable penalty will be imposed.
- BA shall ensure to depute a Safety Supervisor for managing a complete safety management system for the work as per the following safety structure.
- The BA for the RRG work shall depute one Safety supervisor.

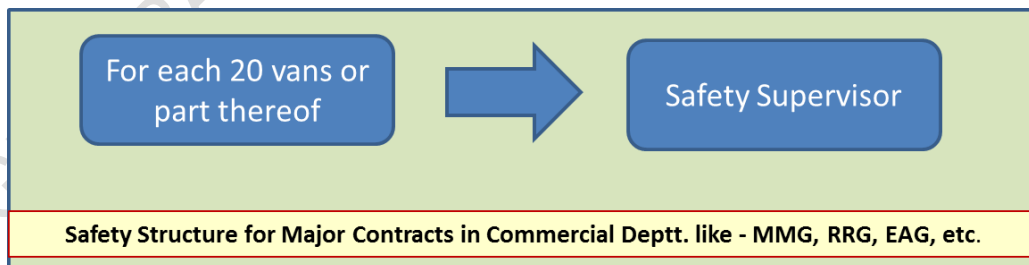

Doc. Title	GENERAL CONDITIONS OF CONTRACT - COMPOSITE WORKS	
Rev. No	0	Page 88 of 104

### **Annexure 3.7 (Refer Para 4.0)**

#### **General Safety Conditions for the major contract work in O&M of street light group:**

A BA awarded a major contract work in operation and maintenance of street light group will be required to fulfil the following safety conditions:

- BA shall provide Safety Policy and safety objectives of their company.
- BA shall comply with all statutory requirements like: applicable acts, regulations, codes of practice, OHSAS Standards, etc.
- BA shall provide the filled safety management questionnaire as per Annexure 1
- BA shall conduct a job risk assessment and provide information as per Annexure 2
- BA shall abide by Safety manuals, guidelines of TPCODL.
- BA shall provide its organisation structure & responsibilities in terms of Safety Management to TPCODL.
- BA shall document the work practices and procedures in terms of Safety Management.
- BA shall ensure safety training and induction program for the employees
- BA shall conduct safety audits & inspections as per TPCODL procedures provided by SAFETY group.
- BA shall provide and ensure the proper usage of the safety equipment PPE as per the TPCODL approved list in annexure 7.
- BA shall ensure periodic inspection of PPE to ensure its serviceability as per the specification given by TPCODL.
- BA shall ensure the adherence to standard operating procedures or guidelines laid down by TPCODL.
- BA shall ensure reporting of any unsafe act, unsafe conditions, near miss, incident or accident to engineer in-charge and SAFETY team of TPCODL.
- BA shall provide safety performance and Safety MIS (*annexure 9*) to engineer in-charge and SAFETY group periodically. Based on any non-confirmation to the safety procedures and guidelines, BA is liable to be negatively marked for his performance and suitable penalty will be imposed.
- Each BA shall ensure to depute a Safety Supervisor for managing a complete safety management system for the work awarded as per the below structure.



Doc. Title	GENERAL CONDITIONS OF CONTRACT - COMPOSITE WORKS	
Rev. No	0	Page 89 of 104

#### **Annexure 4 (Refer Para 3.3)**

##### **Safety Undertaking by way of Affidavit**

I \_\_\_\_\_ s/o \_\_\_\_\_ R/o \_\_\_\_\_ (AUTHORIZED REPRESENTATIVE/PARTNER/DIRECTOR/PROPRIETOR ) of M/S \_\_\_\_\_ (name of company/firm) having its office at (Complete address of Company), authorized vide power of attorney dated -----/Board resolution dated----/letter of authority dated----, hereinafter referred to as **Contractor [or Business Associate (BA)]** which expression shall, unless it be repugnant to or inconsistent with the meaning or context thereof, be deemed to include its heirs, executors, administrators, and assigns do hereby affirm and undertake as under :

1. The present undertaking shall remain in force from the date of execution of contract awarded by TPCODL and shall be valid till the date of termination of the said contract by either parties. The undertaking is binding on me (contractor) as well as my sub-contractor and its employees, representatives etc.
2. That I(the contractor) will be responsible and liable to comply and abide by all the safety rules, instructions and regulations as may be specified and laid down by The TP Central Odisha Distribution Limited (TPCODL) so as enable TPCODL to achieve its goal of Zero On site incidences.
3. That the Contractor shall be fully responsible for ensuring occupational health and safety of its employees, representatives, agents as well as of its subcontractor's employees, at all times during the discharge of their respective obligations under the contract including any methods adopted for performance of their tasks / work.
4. That Contractor shall ensure ,at its own expense to arrange for and procure, implement all requisite accident prevention tools, first aid boxes, personal protective equipment, fire extinguisher, safety training, Material Safety Data Sheet, pre-employment medical test, etc. for operations & activities including as & when so specified by TPCODL specifically. , failing which TPCODL shall be entitled, but not obliged, to provide the same and recover the actual cost thereof from the Contractor's payments.
5. That the Contractor shall engage adequate and competent Safety – Supervisor / Engineer / Manager / Skilled persons at site as per the Para 5 (Qualification and experience of safety personnel) and Annexure 3 of Contract Safety Management.
6. That the Contractor shall engage the competent Site – Supervisor with each group of workers for safe and correct workmanship, proper co-ordination of material and site work as per contract.

Doc. Title	GENERAL CONDITIONS OF CONTRACT - COMPOSITE WORKS	
Rev. No	0	Page 90 of 104

7. That the Contractor shall immediately replace supervisor in case it is found to be not up to the level of skill and experience required as in skill and experience required in *annexure 5* of this document, but any such replacement shall be only with the prior concurrence of TPCODL .
8. That the Contractor and its subcontractors shall abide by all the safety guidelines as per Safety Manual, Contract Safety Management and other guidelines issued from time to time by TPCODL during the contract period.
9. That in case the Contractor and/or any of its Subcontractor fail to ensure the compliance as required in terms of this undertaking the Contractor shall keep and hold TPCODL / its directors / officers / employees indemnified against any / all losses / damage / expense / liability / fines / compensation / claims / action / prosecutions or the like which might be suffered by TPCODL or to which TPCODL might get exposed to as a result of any breach /wilful negligence /deliberate default on the part of the Contractor /Subcontractor in complying with the same. Contractor shall also furnish any press release, clarification etc. if sought by TPCODL for any near miss or safety violations, accidents, which are attributable to fault of Contractor.

DEPONENT

VERIFICATION

Verified at Bhubaneswar on this      Day of      20     that the contents of the above affidavit are true and correct and nothing material has been concealed therefrom

DEPONENT



Doc. Title	GENERAL CONDITIONS OF CONTRACT - COMPOSITE WORKS	
Rev. No	0	Page 91 of 104

**Annexure 5 (Refer Para 5.4)**

**SKILL / QUALIFICATION REQUIRED FOR ELECTRICIAN AND ELECTRICAL SUPERVISOR**

**Skill / Qualifications Required for Electrician (*Certificate of Competency Class-II*):**

1. Formal education in ITI – Wireman/ Electrician trade.

OR

2. Working experience of minimum three years of practical wiring.

OR

3. Have completed three years apprenticeship course through Apprenticeship Advisor, Govt. of Odisha / other state Govt. in the trade of Lineman / Wireman / Electrician.
4. A candidate must have attained the age of Eighteen years.

**Skill / Qualifications Required for Electrical Supervisor (*Certificate of Competency Class-I*):**

1. Have at least five years' experience of practical wiring after passing the certificate of competency class-II i.e. electrician.

OR

2. Recognized Degree or Diploma or equivalent qualification in Electrical Engineering from any Technical institute / College or University recognized by the Board.

AND

Must have completed the training/job in rectifying the common defects in electrical line and power installation for a period of one and three years after passing Degree or Diploma respectively

OR

3. Possessing the valid certificate of certificate of competency class – 1 (Electrical Supervisor)

Doc. Title	GENERAL CONDITIONS OF CONTRACT - COMPOSITE WORKS	
Rev. No	0	Page 92 of 104

**Annexure 6 (Refer Para 5.6)**

**Training Module for BAs Worker & Supervisor**

**Training for BA Supervisor**

**Duration – 02 Hrs / Month**

**Methodology:** Lecture and Practical Demonstration of Safety Zone Creation

**Session: 1**

**Topic:** Electrical Safety Aspects

**Sub Topics:**

1. Learning specifics of HT & LT Network of zone
2. Major type of HT / LT / service lines / street light maintenance works
3. Understanding the need of Safety
4. Understanding the safe process of maintenance :
  - Planning of the maintenance job
  - Availability of men, material & machine, PPEs, Safety gear and approved PTW
  - Briefing of the job by the supervisor of the TPCODL
  - Identification of Risks associated with the maintenance work and planning for controlling measures by TPCODL supervisor
  - Creation of safety zone by TPCODL supervisor and satisfying that the network is dead – Use of Neon Tester, Shorting Chain and Safety Tagging
  - Start of the work – Right person for the right job
  - Alert supervision
  - Completion of the job – Check points
  - Energization of network
  - Actions to be taken in case of some accident

**Session: 2**

**Topic:** Use of Electrical Testing Equipment

**Methodology:** Lecture and Practical Demonstration

**Sub Topics:**

1. Meggar, Hi Pot, Clamp On Meter, Neon Tester, Discharge Rod, Line tester etc.

**Session: 3**

**Topic:** Awareness of Electrical Safety Aspects

- A. Understanding the need of this Training and Safety
- B. Learning specifics of HT & LT Network
- C. Major type of work to be carried out in zones
- D. Switching Operations (Do's & Don'ts) including Street Light Switching
- E. Working on Height (*practical demo also*)
- F. Understanding the Safe Process of Maintenance / Working:
  - Planning of the job
  - Availability of men, material & machine, PPEs, Safety gear and approved PTW
  - Briefing of the job by the supervisor
  - Permit to Work
  - Safety Tagging and Lock Out Tag out

Doc. Title	GENERAL CONDITIONS OF CONTRACT - COMPOSITE WORKS	
Rev. No	0	Page 93 of 104

- Identification of Risks associated with the work to be carried out and planning for controlling measures by proper supervision
- Concept of "**Safety Zone**"
- Identification and use of Neon Tester, Shorting Chain, Clamp On Meter, Hi Pot, Meggar etc.
- Completion of the job – Check points
- Accident Theory & Incident Reporting
- Actions to be taken in case of some accident

#### **Session: 4**

**Topic: Identification, Demonstration and Usages of Tools, PPEs and other Safety Gears and demonstration of working on HT pole**

#### **Session: 5**

**Topic: Practical demonstration of Safety Zone creation**

### **FREQUENCY**

#### **Regular Safety Training Program**

- It will be conducted for all field & supervisor staff of BA in such a manner that all BA Personnel attend at least two hours safety training during every month.

#### **One Day Induction Safety Training Programs:**

- This training will be for the new BA's personnel, who have been cleared by the Cross Functional Panel to undergo Safety training and who are likely to be deployed at various work sites of TPCODL by the BA, as a part of AMC / Work Contract.

#### **Duration / Periodicity:**

- Duration and periodicity has been defined above. However, this is subject to change at the discretion of TPCODL.

Doc. Title	GENERAL CONDITIONS OF CONTRACT - COMPOSITE WORKS	
Rev. No	0	Page 94 of 104

**Annexure 7 (Refer Para 5.7)**



**LIST OF PERSONAL PROTECTIVE EQUIPMENT AND TESTING FREQUENCY**

Sl. No.	Name of PPE	IS / EN Standard	Testing Frequency	Remarks	Ref Brand & Model
01	Leather Safety Shoes (Color – Black) with PU toe cap.	IS:15298 (Part-2)	Monthly and visual check every day for any crack or damage in the leather or sole.		BATA (Model No.- Endura L/C)  Liberty (Model No. – 7198-01 HT Barton Black – Warrior)
02	HDPE Safety helmet with chin strap and ratchet type for adjustment.	IS:2925-1984	Monthly and visual check every day for any crack in shell.		Karam (PN Safetech )  Joseph Leslie  Accent Industries  Honeywell
03	Full body harness (Safety belt)	EN 361	Monthly and visual check every day of the bends and the harness.		Karam (PN Safetech )  Joseph Leslie  Accent Industries
04	Electrical Safety Gloves	EN: 60903 CE marked	Weekly and visual check for any crack and blow test before every work.	Manufactured not beyond 12 months.	Make Sparian / Sumitech / CATU supplied with inner cotton glove with over glove of split leather.
05	Full face visor with safety helmet	EN: 166 CE marked (Visor)	Monthly and visual check every day for any crack in shell.	Clear acrylic visor attached with safety helmet.	Karam (PN Safetech )  Joseph Leslie  Accent Industries  Honeywell
06	Fire Proof jacket for chest protection		Monthly and visual check every day.		
07	Safety Chain for shorting cum earthing.	As per TPCODL standard	Weekly and visual check before every work.	Made of brass, Total length – 5.5 meters and made of 12 SWG.	

*Note:*

1. Any other Personal Protection Equipment required beyond above list will be according to BIS or EN Standards.
2. All Personal Protection Equipment will be checked by the engineer in-charge or SAFETY group of TPCODL.
3. Safety Representative of the BA has to maintain the record of the availability, condition and checking of the PPEs.
4. All tools required as per the contract must be according to respective IS / EN standards.
5. TPCODL may revise or add the above list of PPE and their specifications as and when feel necessary. The information about new specifications /models will be circulated by the Engineer In-charge (EIC), which shall adhere by the business associated in the shortest possible time. The EIC shall issue a memo / instruction to BA with timeline for implementation. Any delay will be treated as non-compliance / safety violations. Refer picture of each PPE given in next page.

**Pictures of PPE for reference purpose.**

Sl. No.	Name of PPE	IS / EN Standard	Picture
01	Leather Safety Shoes (Color – Black) with PU toe cap.	IS:15298(Part-2) and with test report of electrical resistance.	
02	HDPE Safety helmet with chin strap and ratchet type for adjustment.	IS:2925-1984	
03	Full body harness (Safety belt)  The straps at shoulder and thigh shall have full pad for comfort. The back shall be so designed that harness straps do not tangle with each other.	EN 361:2002 EN 358 : 2000 IS: 3521:1991/2002	

04	Electrical Safety Gloves – Composite type Soft electrical gloves as per size of individual.	EN: 60903 CE marked	
05	Full face visor with safety helmet	EN: 166 CE marked (Visor)	
06	Fire Proof jacket for chest protection		
07	Safety Chain for shorting cum earthing.	As per TPCODL standard	
08	Reflective jacket to each workmen	As per TPCODL standard	

Note : Picture shown are for indicative purpose only. Actual product may differ.

**Annexure 8 (Refer Para 5.8) LIST OF AUDITS TO BE CONDUCTED**

Audits	Responsibility	Freq.	Ref. Doc.
Permit to Work & Field Audit	BA Safety Representative	Weekly	F04 (COR P - 12)
Tool Bag & PPE's Audit		Weekly	F06 (COR P - 12)
First Aid Box Maintenance Record		Fortnightly	F08 (COR P - 12)
Fire Extinguisher Record <i>(Applicable for the BA involved in major construction works and have storage of flammable material at worksite)</i>		Monthly	F09 (COR P - 12)
Safety Talk Register		Weekly	F18 (COR P - 12)
Site Safety Audit		Daily	F29A (COR P - 12)

Note:

1. (BA Safety Representative has to use the formats as per Safety process COR – P – 12 of TPCODL)

**Annexure 9 (Refer Para 5.9)**

**PERFORMANCE REPORT – SAFETY**

**FOR THE MONTH OF.....**

Name of BA : .....

Name of the Project and Purchase order No: .....

Date of commencement of work: .....

Man Hour Worked in this month (No. of employees X 8 Hrs + Overtime): .....

Cumulative Man Hour worked: .....

Total Number of Minor Injury (this month): ..... Minor Injury (Total).....

Major Injury (this month): ..... Major Injury (Total): .....

Detail of the Incident / Sub Standard Acts and Condition

Activity	This Month	Cumulative (Total)	Day Lost (this month)	Days Lost (Cumulative)
No. of the Incident				
No. of lost time injuries				
No. of dangerous occurrences				
No. of near miss reported				
Substandard Act/Conditions observed			Attach details of observation of this month	
Safety Violation Notice received (from TPCODL) (both in numbers and in Rs.)	No.	No.	No. of violation letter received and compliance report for the TPCODL.	
	Rs.	Rs.		

*Note: Cumulative means total from date of commencement of work according to the contract.*

Detail of the Accident / Near Miss Incidents:

Date and Time	Type of the incident	Name of Employee	Brief Description	Corrective and Preventive actions recommended

Details of the Safety Violations:



Doc. Title	<b>GENERAL CONDITIONS OF CONTRACT - COMPOSITE WORKS</b>	
Rev. No	0	Page 99 of 104

Date and Location	Brief Description	Name of employee involved	Action Taken

Detail of the Safety Talk / Tool Box Talk / Safety Training

Date and Location	Topic (s)	Total Number of employees (Worker / Supervisor)	Number of participants (Worker / Supervisor)

Detail of the Safety Meeting

Date and Location	Number of participants	Topics discussed	Major Observations / Innovation

Detail of the Safety Inspection /Audit: (as per TPCODL site audit checklist F29A(COR-P-12))

Date	Area / Location	Major Observations	Recommendations	Action Taken

Any other Safety, Occupational Health, Environment & Disaster Management Promotional Activity (During this month):

Date	Location	Activity	Level of Participation	Number of participation

Signature of the BA Safety Representative  
HoG

Signature of ZM /

Name, E. No. and Date

Name, E. No. Date.

*Note: The original form to be deposited with Engineer in-charge and a copy to SAFETY group on or before 5<sup>th</sup> of every month along with bill. List of training of the current month and status of PPE to be also mentioned individual wise.*

*BA may include additional lines if required. The TPCODL may revise the format as and when deemed required.*

Doc. Title	GENERAL CONDITIONS OF CONTRACT - COMPOSITE WORKS	
Rev. No	0	Page 100 of 104

**ANNEXURE-M**  
**VENDOR APPRAISAL FORM**

<b>TO BE SUBMITTED BY VENDOR (To be filled as applicable)</b>			
<b>VENDOR:</b>			
<b>1.0</b>	<b>DETAILS OF THE FIRM</b>		
	1.1	NAME (IN CAPITAL LETTERS)	:
	1.2	TYPE OF CONCERN (PROPRIETARY) Partnership, Pvt. Ltd., Public Ltd. etc.	:
	1.3	YEAR OF ESTABLISHMENT	:
	1.4	LOCATION OF OFFICE POSTAL ADDRESS TELEGRAPHIC ADDRESSES, TELEX NO. FAX NO.	:
	1.5	LOCATION OF MANUFACTURING UNITS	:
		i) UNITS 1	:
		ii) OTHER UNITS	:
<b>2.0</b>	<b>PRODUCTS MANUFACTURED</b>		
<b>3.0</b>	<b>TURNOVER DURING THE LAST 3 YEARS (TO BE VERIFIED WITH THE LATEST PROFIT &amp; LOSS STATEMENT).</b>		
<b>4.0</b>	<b>VALUE OF FIXED ASSETS</b>		
<b>5.0</b>	<b>NAME &amp; ADDRESS OF THE BANKERS</b>		
<b>6.0</b>	<b>BANK GUARANTEE LIMIT</b>		
<b>7.0</b>	<b>CREDIT LIMIT</b>		
<b>8.0</b>	<b>TECHNICAL</b>		
	8.1	NO.OF DESIGN ENGINEERS (INDICATE NO.OF YEARS EXPERIENCE IN RELATED FIELDS)	:
	8.2	NO.OF DRAUGHTSMEN	:
	8.3	COLLABORATION DETAILS (IF ANY)	:
		8.3.1 DATE OF COLLABORATION	:
		8.3.2 NAME OF COLLABORATOR	:

Doc. Title	GENERAL CONDITIONS OF CONTRACT - COMPOSITE WORKS	
Rev. No	0	Page 101 of 104

		8.3.3 RBI APPROVAL DETAILS	:
		8.3.4 EXPERIENCE LIST OF COLLABORATOR	:
		8.3.5 DURATION OF AGREEMENT	:
	8.4	AVAILABILITY OF STANDARDS / DESIGN PROCEDURES / COLLABORATOR'S / DOCUMENTS (CHECK WHETHER THESE ARE LATEST/CURRENT)	:
	8.5	TECHNICAL SUPPORT, BACK-UP GUARANTEE, SUPERVISION, QUALITY CONTROL BY COLLABORATOR (WHEREVER ESSENTIAL). (THIS CLAUSE IS RELEVANT WHEN VENDOR'S EXPERIENCE IS INADEQUATE)	:
	8.6	QUALITY OF DRAWINGS	:
<b>9.0</b>	<b>MANUFACTURE</b>		
	9.1	SHOP SPACE, LAYOUT LIGHTING, VENTILATION, ETC.	:
	9.2	POWER (KVA)	:
		MAINS INSTALLED	:
		UTILISED	:
		STANDBY POWER SOURCE	:
	9.3	MANUFACTURING FACILITIES (ATTACH LIST OF EQUIPMENT AS APPLICABLE)	:
		9.3.1 MATERIAL HANDLING	:
		9.3.2 MACHINING	:
		9.3.3 FABRICATION	:
		9.3.4 HEAT TREATMENT	:
		9.3.5 BALANCING FACILITY	:
		9.3.6 SURFACE TREATMENT PRIOR TO PAINTING/ COATING, POLISHING, PICKLING, PASSIVATION, PAINTING, ETC.	:
	9.4	SUPERVISORY STAFF	:
	9.5	ADEQUACY OF SKILLED LABOURS (MACHINISTS, WELDERS, ETC.)	:
	9.6	NO. OF SHIFTS	:
	9.7	TYPE OF MATERIAL HANDLED (SUCH AS CS, SS, ETC.)	:

Doc. Title	<b>GENERAL CONDITIONS OF CONTRACT - COMPOSITE WORKS</b>	
Rev. No	0	Page 102 of 104

	9.8	WORKMANSHIP	:
	9.9	MATERIAL IN STOCK AND VALUE	:
	9.10	TRANSPORT FACILITIES	:
	9.11	CARE IN HANDLING	:
<b>10.0</b>	<b>INSPECTION / QC / QA / TESTING</b>		
	10.1	NUMBER OF PERSONNEL (INDICATE NO.OF YEARS OF EXPERIENCE)	:
	10.2	INDEPENDENCE FROM PRODUCTION	:
	10.3	AVAILABILITY OF PROCEDURAL WRITE UP/QUALITY PLAN	:
	10.4	INCOMING MATERIAL CONTROL AND DOCUMENTATION	:
	10.5	RELIABILITY/REPUTATION OF SUPPLY SOURCES	:
	10.6	STAGE INSPECTION AND DOCUMENTATION	:
	10.7	SUB-ASSEMBLY & DOCUMENTATION	:
	10.8	FINAL INSPECTION AND DOCUMENTATION	:
	10.9	PREPARATION OF FINAL DOCUMENTATION PACKAGE	:
	10.10	TYPE TEST FACILITIES	:
	10.11	ACCEPTANCE TEST FACILITIES	:
	10.12	CALIBRATION OF INSTRUMENTS AND GAUGES (WITH TRACEABILITY TO NATIONAL STANDARDS) (ATTACH LIST)	:
	10.13	STATUTORY APPROVALS LIKE BIS, IBR, ETC.(AS APPLICABLE)	:
	10.14	SUB-VENDOR APPROVAL SYSTEM AND QUALITY CONTROL	:
	10.15	DETAILS OF TESTS CARRIED OUT AT INDEPENDENT RECOGNISED LABORATORIES	:
		i) FURNISH LIST OF TESTS CARRIED OUT AND THE NAME OF THE LABORATORY WHERE THE TESTS WERE CONDUCTED	:
		ii) CHECK AVAILABILITY OF CERTIFICATES AND REVIEW THESE WHEREVER POSSIBLE	:
<b>11.0</b>	<b>EXPERIENCE (INCLUDING CONSTRUCTION / ERECTION / COMMISSIONING) TO BE FURNISHED IN THE FORMAT INDICATED IN APPENDIX)</b>		
<b>12.0</b>	<b>SALES, SERVICE AND SITE ORANISATIONAL DETAILS</b>		

Doc. Title	GENERAL CONDITIONS OF CONTRACT - COMPOSITE WORKS	
Rev. No	0	Page 103 of 104

13.0	<b>CERTIFICATE FROM CUSTOMERS (ATTACH COPIES OF DOCUMENTS)</b>	:
14.0	<b>POWER SITUATION</b>	:
15.0	<b>LABOUR SITUATION</b>	:
16.0 *	<b>APPLICABILITY OF SC/ST RELAXATION (Y/N) IF YES, SUPPORTING DOCUMENTS TO BE ATTACHED</b>	
17.0	<b>ORGANIZATIONAL DETAILS</b> 1. PF NO 2. ESI NO 3. INSURANCE FOR WORK MAN COMPENSATION ACT NO 4. ELECTRICAL CONTRACT LIC NO 5. ITCC / PAN NO 6. SALES TAX NO 7. WC TAX REG. NO	:
18.0	<b>DOCUMENTS TO BE ENCLOSED:</b> 1. FACTORY LICENSE 2. ANNUAL REPORT FOR LAST THREE YEARS 3. TYPE TEST REPORT FOR THE ITEM 4. PAST EXPERIENCE REPORTS 5. ISO CERTIFICATE –QMS, EMS, OHAS, SA 6. REGISTRATION OF SALES TAX 7. COPY OF TIN NO. 8. COPY OF SERVICE TAX NO. 9. REGISTRATION OF CENTRAL EXCISE 10. COPY OF INCOME TAX CLEARANCE. 11. COPY OF PF REGISTRATION 12. COPY OF ESI REGISTRATION 13. COPY OF INSURANCE FOR WORK MAN COMPENSATION ACT NO 14. COPY OF ELECTRICAL CONTRACT LIC NO 15. COPY OF PAN NO 16. COPY OF WC TAX REGISTRATION 17. DOCUMENTS IN SUPPORT OF SC/ST RELAXATION AT S.NO.16.0 18. GST Registration No	

\* **Classification of BA s under SC/ST shall be governed under following guidelines:**

- **Proprietorship/ Single Ownership Firm:** Proprietor of the firm should be from SC/ST community. Governing document shall be Proprietorship Deed.
- **Partnership Firm:** Only such firms shall qualify which have SC/ST partners holding equal to or more than 50% of the total ownership pattern of the firm. Governing document shall be Partnership Deed.
- **Private Limited Company:** Only such firms shall qualify which have SC/ST directors holding equal to or more than 50% of the total ownership pattern of the firm. Governing document shall be Memorandum of Understanding (MoU) and/or Article of Association (AoA).

**NOTE: Certification from SC/ST Commission shall be required for deciding upon SC/ST status of a person.**

Doc. Title	GENERAL CONDITIONS OF CONTRACT - COMPOSITE WORKS	
Rev. No	0	Page 104 of 104

**ANNEXURE-N**  
**MANUFACTURER AUTHORIZATION FORM**

*(To be submitted on OEM's Letter Head)*

Date: .....

Tender Enquiry No.: .....

To,  
Chief (Procurement & Stores)  
TP Central Odisha Distribution Limited,  
Bhubaneswar

Sir,

WHEREAS M/s. *[name of OEM]*, who are official manufacturers of ..... having factories at *[address of OEM]* do hereby authorize M/s *[name of bidder]* to submit a Bid in relation to the Invitation for Bids indicated above, the purpose of which is to provide the following Goods, manufactured by us

.....

and to subsequently negotiate and sign the Contract.

We hereby extend our full guarantee and warranty in accordance with the Special Conditions of Contract or as mentioned elsewhere in the Tender Document, with respect to the Goods offered by the above firm in reply to this Invitation for Bids.

We hereby confirm that in case, the channel partner fails to provide the necessary services as per the Tender Document referred above, M/s *[name of OEM]* shall provide standard warranty on the materials supplied against the contract. The warranty period and inclusion / exclusion of parts in the warranty shall remain same as defined in the contract issued to their channel partner against this tender enquiry.

Yours Sincerely,

For .....

Authorized Signatory

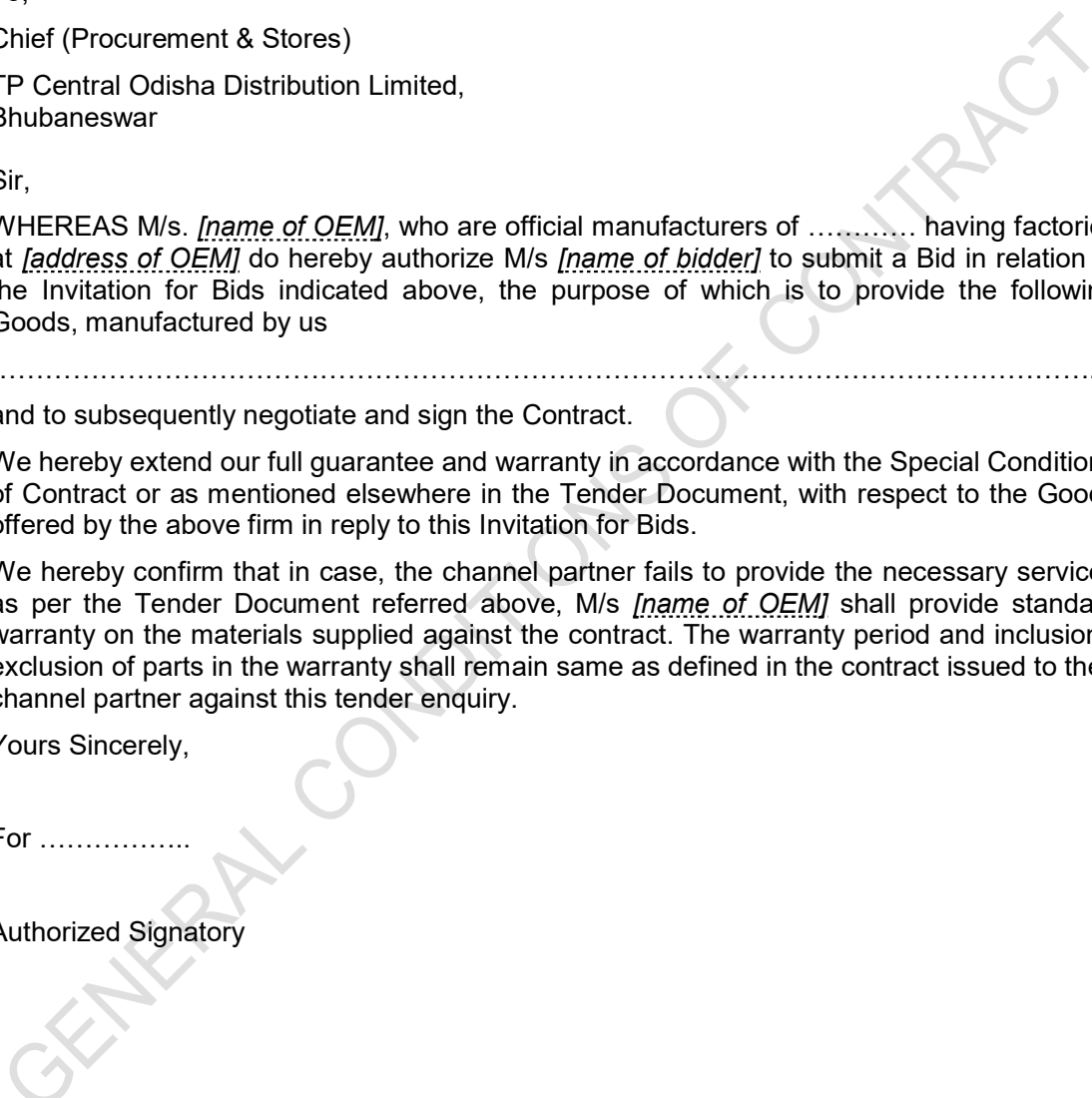

## HEALTH AND SAFETY POLICY

**We, at Tata Power, reaffirm our belief that the health and safety of our stakeholders is of the utmost importance and takes precedence in all our business decisions. In pursuit of this belief and commitment, we strive to:**

- Maintain and proactively improve our management systems to minimize health and safety hazards to our stakeholders and all others influenced by our activities.
- Comply and endeavour to exceed all applicable occupational health & safety legal and other requirements by setting the highest standards.
- Integrate health & safety procedures and best practices into every operational activity with assigned line-functional responsibilities at all levels, for improving and sustaining health & safety performance.
- Involve our employees in maintaining a safe and healthy work environment through risk assessments, periodic reviews of operational procedures, safe work methods and adoption of new technology.
- Develop a culture of safety through active leadership and provide appropriate training at all levels to enable employees developing their skills to work safely.
- Incorporate appropriate health & safety criteria into business decisions for selection of plant and technology, performance appraisal of individuals and appointments in key positions.
- Ensure availability at all times of appropriate resources to fully implement the health & safety policy of the company.
- Promptly report incidents, investigate for root causes and ensure lessons learnt shared and deployed across the company.
- Ensure service providers and their workmen align with company's safety codes and practices for the health and safety of personnel working with us.
- Set safety & health metrics as indicators of excellence, monitor progress and continually improve performance.

We shall actively communicate this policy to all stakeholders by suitable means and periodically review its relevance in continuously changing business environment.



(Praveer Sinha)  
CEO & Managing Director

Date: 15<sup>th</sup> June, 2018

**TATA POWER**

Lighting up Lives!

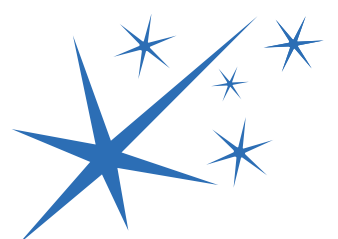

## CORPORATE SUSTAINABILITY POLICY

At Tata Power, our Sustainability Policy integrates economic progress, social responsibility and environmental concerns with the objective of improving quality of life. We believe in integrating our business values and operations to meet the expectations of our customers, employees, partners, investors, communities and public at large

- We will uphold the values of honesty, partnership and fairness in our relationship with stakeholders
- We shall provide and maintain a clean, healthy and safe working environment for employees, customers, partners and the community
- We will strive to consistently enhance our value proposition to the customers and adhere to our promised standards of service delivery
- We will respect the universal declaration of human rights, International Labour Organization's fundamental conventions on core labour standards and operate as an equal opportunities employer
- We shall encourage and support our partners to adopt responsible business policies, Business Ethics and our Code of Conduct Standards
- We will continue to serve our communities:
  - By implementing sustainable Community Development Programmes including through public/private partnerships in and around our area of operations
  - By constantly protecting ecology, maintaining and renewing bio-diversity and wherever necessary conserving and protecting wild life, particularly endangered species
  - By encouraging our employees to serve communities by volunteering and by sharing their skills and expertise
  - By striving to deploy sustainable technologies and processes in all our operations and use scarce natural resources efficiently in our facilities
  - We will also help communities that are affected by natural calamities or untoward incidence, or that are physically challenged in line with the Tata Group's efforts

The management will commit all the necessary resources required to meet the goals of Corporate Sustainability.



(Praveer Sinha)  
CEO & Managing Director

Date: 15<sup>th</sup> June, 2018

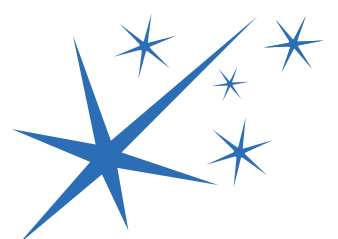



**TPCODL**  
**TPWODL**

**TPNODL**  
**TPSODL**

**Specification No:** NA

**Specification Name:** Technical Specification for Danger Board

**DANGER BOARD**

**GENERAL TECHNICAL PARTICULARS**

SL. NO.	TECHNICAL PARTICULAR	DESIRED VALUE
1	Size of the danger board	250mm X 200 mm (11kV & LT)
2	Thickness of Sheet	1.6mm
3	Front side of the board	The plate is vitreous enamelled white with letters, figures and the conventional skull and cross-bones in signal red colour.
4	Rear side of the board	Rear Side of the plate is black enamelled
5	Letter Size	As per IS 2551/1982
6	Holes	10 mm dia. holes at suitable place as per sketch for fixing
7	Languages	The language will be Odia and English
8	Marking	TPCODL/ TPNODL/ TPWODL/ TPSODL, Manufacture's name or trademark, Year of Manufacturing.

**DRAWINGS**

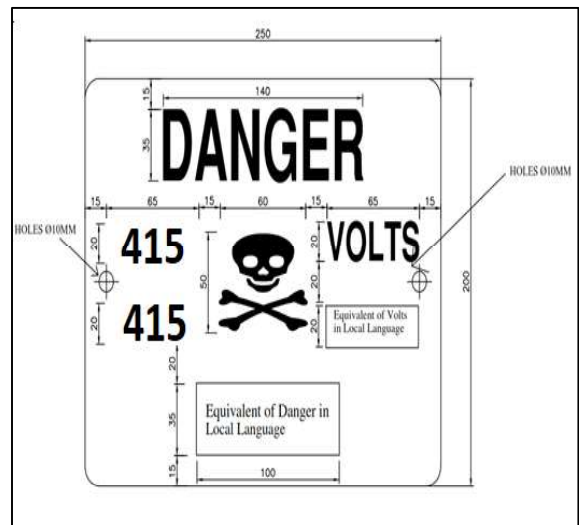
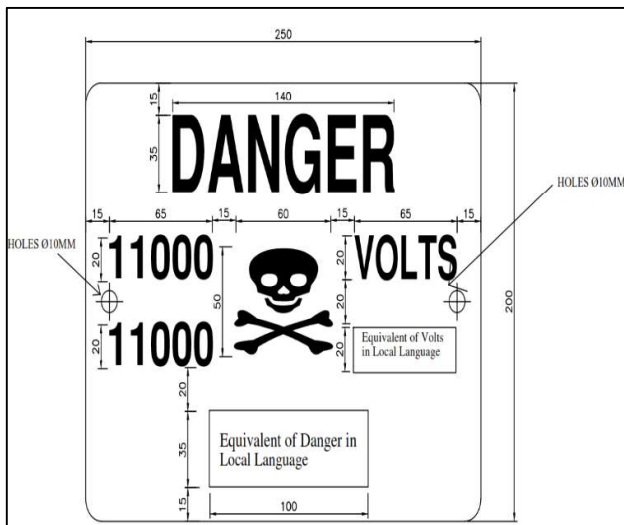

**Note:** -All Dimensions are in mm unless noted otherwise specified.



**Specification No:** ENG-EHV-1021

**Specification Name:** Technical Specification for  
33KV Lightning Arrester (10 KA)

## CONTENTS

1. SCOPE
2. APPLICABLE STANDARDS
3. CLIMATIC CONDITIONS OF THE INSTALLATION
4. GENERAL TECHNICAL REQUIREMENTS
5. GENERAL CONSTRUCTIONS
6. MARKING
7. TESTS
8. TYPE TEST CERTIFICATES
9. PRE-DISPATCH INSPECTION
10. INSPECTION AFTER RECEIPT AT STORES
11. GUARANTEE
12. PACKING
13. TENDER SAMPLE
14. QUALITY CONTROL
15. TESTING FACILITIES
16. MANUFACTURING FACILITIES
17. SPARES, ACCESSORIES AND TOOLS
18. DRAWINGS AND DOCUMENTS
19. TRAINING
20. SCHEDULE "A" GUARANTEED TECHNICAL PARTICULARS
21. SCHEDULE "B" DEVIATIONS

### 1. SCOPE:

This specification covers the design, manufacture, testing and supply of 33kV, 10kA, Station class-SL, (Station class-II) and 33 KV ,10 KA –SM (class –III), Metal Oxide Gap less Polymeric Lightning Arrester. The specific requirements are covered in the enclosed technical data sheet. Some of the parts that may have not been specifically included, but otherwise form part of the Lightning arrester as per standard practice or necessary for proper operation, will be deemed to be also included in this specification. The successful bidder shall not be eligible for any extra charges for such accessories etc. Scope also includes transportation & unloading at store / site.

### 2. APPLICABLE STANDARDS:

The equipment covered by this specification shall unless otherwise stated, be designed, manufactured and tested in accordance with the latest editions of the following Indian, International Standards and shall conform to the regulations of the local authorities:

IEC 60099-4	Specification for surge arrestor without gap for AC System
IS 15086	Specification for Metal Oxide Gap less Lightning arresters for alternating current System
IS 6209	Method of Partial Discharge Measurement
IS 8704 & IS 731	Guide for selection of creepage distance of polymeric housing insulator.
ISO 48	Rubber, vulcanized or thermoplastic -- Determination of hardness (hardness between 10 IRHD and 100 IRHD).
IEC 60721-3-2	Classification of environmental conditions. Classification of groups of environmental parameters and their severities. Transportation
IEC 60071	Insulation co-ordination -- Part 1 definitions, principles and rules; -- Part 2: Application Guide
IEC 60815-1	Selection and dimensioning of high-voltage insulators intended for use in polluted conditions –Part 1: Definitions, information and general principles
IS 2629	Recommended Practice for Hot-Dip Galvanizing of Iron and Steel
IS 2633	Methods for testing uniformity of coating of zinc coated articles
IS 4759	Hot-dip zinc coatings on structural steel and other allied products

### 3. CLIMATIC CONDITIONS:

1	Maximum ambient temperature	50 deg C
2	Max. Daily average ambient temp	35 deg C
3	Min Ambient Temperature	0 deg C
4	Maximum Humidity	95%
5	Average Annual Rainfall	1500mm
6	Average No. of rainy days per annum	120
7	Altitude above MSL not exceeding	1000m
8	Wind Pressure	300 Km/hr
9	Earthquakes of an intensity in horizontal direction	equivalent to seismic acceleration of 0.3g
10	Earthquakes of an intensity in vertical direction	equivalent to seismic acceleration of 0.15g (g being acceleration due to gravity)

TPCODL/TPWODL/TPNODL/TPSODL service area has heavy saline conditions along the coast and High cyclonic Intensity winds with speed upto 300 Kmph. The atmosphere is generally laden with mild acid and dust in suspension during the dry months and is subjected to fog in cold months.

#### 4. GENERAL TECHNICAL REQUIREMENTS:

SL. NO.	TECHNICAL PARTICULARS (Class-SL,Class-II)	DESIRED VALUE
1	Installation	Outdoor
2	Reference standards (Latest Amend.)	IS 15086:Part.4(2017), IEC 60099
3	Arrester Type and Housing	Metal Oxide Gapless Cage type with Polymeric housing
4	Normal System Voltage	33 kV
5	Highest System Voltage	36 kV
6	Rated Frequency	50 Hz
7	Maximum Continuous Operating Voltage (M.C.O.V)	25 kV (rms)
8	Arrester Rating	30 kV (rms)
9	<b>Discharge Current</b>	
a	Nominal Discharge Current	10 kA
b	Switching impulse discharge current	0.5kA

<b>SL. NO.</b>	<b>TECHNICAL PARTICULARS (Class-SL,Class-II)</b>	<b>DESIRED VALUE</b>
10	Short Circuit rating	40 kA
11	<b>Voltage Withstand on Arrester Housing</b>	
a	Standard rated short duration Power Frequency withstand Voltage (Dry/Wet) as per IS:2165	70kV (rms)
b	Standard rated Lightning Impulse withstand Voltage (Peak in kV)	170kV (Peak)
12	Lightning Impulse Protection Level (at 10kA)	115 kV
13	<b>Long Duration Current</b>	
a	Peak Current	400A
b	Virtual duration of Peak T	2000 T (Micro Sec)
14	High Current impulse Operating Duty	100 kA (Peak)
15	Creepage Distance of Arrester Housing	1116 min or 31mm/KV
16	Partial Discharge at 1.05 times M.C.O. V	<10 pc
17	Energy Absorption capacity (KJ/KV)	>=4KJ/KV
18	Repetitive charge transfer withstand (coloumbs), Qrs	>=1.0
19	<b>Temporary over voltage (TOV)</b>	
a	1 sec	51kVp
b	10 sec	49kVp
20	<b>Maximum Lightning Impulse Residual voltage with 8/20 microsecond wave</b>	
a	at 5kA	85kVp
b	at 10kA	90kVp
c	at 20kA	100kVp
21	Maximum switching current impulse residual voltage in kVP at 500 A	73.2 KVP
22	Max. Cantilever Strength	325 kgF
23	Total height of the arrester	To be specified by bidder
24	Total weight of the arrester	To be specified by bidder
25	No. of Metal oxide blocks in arrester	To be specified by bidder
26	Rating of individual ZnO blocks used for assembly	To be specified by bidder
27	Power Losses of the Arrester in watt	To be specified by bidder
28	Type of Mounting	Pedestal
29	Material of Insulating base	UV resistant Fire retardant DMC
30	Insulating Terminal Cap	Polyolefin
31	Material of Nuts and bolts	Stainless Steel

SL. NO.	TECHNICAL PARTICULARS (Class-SM,Class-III)	DESIRED VALUE
1	Installation	Outdoor
2	Reference standards (Latest Amend.)	IS 15086:Part.4(2017), IEC 60099
3	Arrester Type and Housing	Metal Oxide Gapless Cage type and Polymeric housing
4	Normal System Voltage	33 kV
5	Highest System Voltage	36 kV
6	Rated Frequency	50 Hz
7	Maximum Continuous Operating Voltage (M.C.O.V)	25 kV (rms)
8	Arrester Rating	30 kV (rms)
9	<b>Discharge Current</b>	
a	Nominal Discharge Current	10 kA
b	Switching impulse discharge current	1kA
10	<b>Short Circuit rating</b>	40 KA
a	Reduced Short circuit currents	25 kA
b	Low short circuit current with a duration of 1 sec	600±200 kA
c	Prospective symmetrical fault current	40 kA for min 0.2 sec
11	<b>Voltage Withstand on Arrester Housing</b>	
a	Standard rated short duration Power Frequency withstand Voltage (Dry/Wet) as per IS:2165	70kV (rms)
b	Standard rated Lightning Impulse withstand Voltage (Peak in kV)	170kV (Peak)
12	Lightning Impulse Protection Level (at 10kA)	115 kV
13	<b>Long Duration Current</b>	To be provided by bidder
a	Peak Current	To be provided by bidder
b	Virtual duration of Peak T	2400 T (Micro Sec)
14	High Current impulse Operating Duty	100 kA (Peak)
15	Creepage Distance of Arrester Housing	1116 min or 31mm/KV
16	Partial Discharge at 1.05 times M.C.O. V	<10 pc
17	Energy Absorption capacity (KJ/KV)	>=7KJ/KV
18	Repetitive charge transfer withstand (coloumbs),Qrs	1.6 Coloumbs
19	<b>Temporary over voltage (TOV)</b>	
a	1 sec	51kVp
b	10 sec	49kVp
20	<b>Maximum Lightning Impulse Residual voltage with 8/20 microsecond wave</b>	
a	at 5kA	85kVp
b	at 10kA	90kVp

SL. NO.	TECHNICAL PARTICULARS (Class-SM,Class-III)	DESIRED VALUE
c	at 20kA	100kVp
21	<b>Maximum switching current impulse residual voltage in kVP At 500 Amps</b>	73.2KVp
22	Max. Cantilever Strength	325 kgF
23	Total height of the arrester	To be specified by bidder
24	Total weight of the arrester	To be specified by bidder
25	No. of Metal oxide blocks in arrester	To be specified by bidder
26	Rating of individual ZnO blocks used for assembly	To be specified by bidder
27	Power Losses of the Arrester in watt	To be specified by bidder
28	Type of Mounting	Pedestal
29	Material of Insulating base	UV resistant Fire retardant DMC
30	Insulating Terminal Cap	Polyolefin
31	Material of Nuts and bolts	Stainless Steel

## 5. GENERAL CONSTRUCTION:

### 5.1 Assembly:

The surge arresters shall conform in general to IEC-60099-4 ed 3.0

Surge arrester shall be supplied along with the insulating base, terminal connector, insulating terminal cap (Polyolefin) and necessary hardware. The Assembly consists of a stack of Metal Oxide elements arranged in a cage type design. All metal parts shall be of non-rusting and non corroding metal (All ferrous parts shall be Hot Dip Galvanized i.e. HDG). All nuts & bolts shall be with double spring washers. Bolts, screws and pins shall be provided with lock washers. Surge arrester construction shall be suitable to withstand Seismic Loading, Short Circuit Forces and wind load and the force exerted on the arrester base and to the terminal imposed by the line conductor. All similar parts, particularly removable ones, shall be interchangeable.

Arresters shall be completely molded units with absolutely no air volume inside.

Arresters of tubular construction i.e arresters assembled in hollow core insulators with enclosed gas volume are not acceptable due to abrupt short circuit performance and poor sealing mechanism.

- a) Housing shall be polymeric to provide thermal dissipation of heat generated in the metal oxide elements during over voltage and line discharge. Polymeric housing shall be free from flaws affecting the mechanical and electrical strength of the arrester. Housing shall be capable to withstand the desired pollution stresses without flashover. Housing shall be capable to



withstand the temperature rise due to the non uniform field distribution, caused by the pollution on the surface of the housing. The rain sheds / petticoats shall be of polymeric material and shall confirm to IEC 60815.

b) The arrester shall have thermal stability to withstand the heat generated from ZnO element due to continuous operating voltages and surges. It shall remain in undamaged condition, capable protective function.

c) Arrestors shall incorporate anticontamination feature to prevent arrester failure, consequent to uneven voltage gradient across the stack in the event of contamination of the arrester insulating material. These features shall be described in detail when submitting the Bid. Arrestors shall be capable of discharging over voltages occurring during switching of unloaded transformers, capacitors banks and long lines. No radio interferences shall be caused by the arrestors operating at the normal rated voltage.

d) MO resistor diameter shall be mentioned by the bidder at the time of bidding along with its rating . MOV blocks shall have full metallization to have full face contact and to reduce contact resistance between adjacent discs.

e) Surge arresters shall be of cage type construction with no gas volume to ensure that the arrester does not explode during the short circuit test condition. The MOV blocks should be housed in cage of FRP rods appropriately crimped at both end fittings. The housing should be directly molded on stack of MOV blocks without any intermediate interface.

f) The end fittings shall be non-magnetic and of corrosion proof material. The end fittings used in polymer arrester shall be made from aluminum through machining process/pressure die-casting process. Sand casted and gravity casted end fittings are not acceptable due to poor microstructure and porosity issues.

## 5.2 EARTHING PADS:

Suitable earthing pads shall be provided in the lightning arrester and surge counter for earthing.

## 5.3 MECHANICAL STRENGTH:

a) The Lightning Arrester and its base shall withstand rated mechanical terminal load and electromagnetic forces without impairing their operational reliability.

b) The Lightning Arrester shall not come out of their positions by gravity, wind pressure, vibrations or reasonable shocks.

## 5.4 SURGE COUNTER :

a) Cyclometric 5 digit, non-resetting type counter, dial type surge counter shall be provided for each lightning arrester for automatically recording the number of discharges. Each counter shall have a continuous leakage current indicator and shall not require an external power source of



operation. The value of leakage current beyond which the operation is abnormal shall be clearly marked in red colour on the detector.

- b) Surge arrestor shall include a milli ammeter to monitor the leakage current. the milli –ammeter usually bare a red mark at the higher scale regions. Increase of leakage current to the red marked zone is essentially an indication that the arrestor is likely to attain the thermal runaway condition. The qualitative information regarding the arrestor the arrestor health, obtained from the milli-ammeter, helps the user to take preventive measures before the arrestor failure.
- c) Discharge counters and milli-ammeters shall be suitable for mounting on structure and shall be mounted at approximately 1.5 meters above ground level. The reading of the milli-ammeter and counters shall be visible through an inspection glass panel. The terminals shall be of robust and adequate size and shall be so located that incoming and outgoing connections are made with minimum possible bends.
- d) The connecting conductor from lightning arrester earth terminal to the discharge counter incoming terminal shall be insulated for a minimum of 1.1 kV and this insulated conductor shall be supplied along with the arrester by the bidder. The surge arrester surge counter connection shall be done by means insulated multi strand copper cable of minimum size 35 sq.mm to withstand the fault currents during severe operating conditions. Length of the each cable should be considered as 3.5 mtr (min.). This copper cable shall be of black color and shall have fire retardant & UV resistance properties. Approved Make for this Cable is Polycab/KEI/KEC/Sterlite/Finolex/Havells. The cable shall have copper lugs at both ends. Bimetallic strips must be provided along with Surge Counter for bimetallic connections.
- e) The surge arrester shall be designed to operate/ withstand without damage or change in performance for the high current impulse, long duration current impulse corresponding to the discharge class of the surge arrester and nominal discharged current corresponding to the discharge current of the surge with which it is used.
- f) The external and internal parts of the surge monitor shall be hermetically sealed to withstand the atmospheric variation of temperature and humidity, rain and dust encountered in station in which they are installed. RTV silicon sealant to be used. The surge Monitor line terminal shall be solidly connected to the ground terminal of the surge monitor through an inbuilt metal oxide element satisfying the operational requirement.

#### 5.5 CONNECTORS:

Aluminum terminal to be provided for Surge Arrestor. This terminal shall be connected via Standard bolted type connector (L-Shaped) connector with the network equipment via AAAC Panther Conductor. Therefore terminal connector shall be part of Surge Arrestor.



**Specification No:** ENG-EHV-1021

**Specification Name:** Technical Specification for  
33KV Lightning Arrester (10 KA)

## 6. MARKING:

A stainless steel rating plate, of at least 1 mm thickness, shall be fitted to each Lightning Arrester in a visible position and shall carry all the information as specified in the standards. The letters on the rating plate shall be engraved black on the white/silver background. Fixing screws for outdoor use shall be of stainless steel or any other corrosion resistant metals. The Name plate shall be embossed with "PO no. with date" & "TPCODL/TPWODL/TPNODL/TPSODL",

The following information shall be mentioned on the Name Plate

- a) Continuous operating Voltage
- b) Rated Voltage
- c) Rated Frequency
- d) Nominal Discharge Current
- e) Pressure relief rated current in kA r.m.s.
- f) Manufacturer's Name
- g) Type and Identification of the complete
- h) Year/Month of Manufacture
- i) Serial Number.
- j) Warrantee/guarantee clause

## 7. TESTS:

All routine, acceptance & type tests shall be carried out in accordance with the relevant IS/IEC. All acceptance tests shall be witnessed by the purchaser/his authorized representative. All the components and fittings shall also be type tested as per the relevant standards. Following tests shall necessarily be conducted on lightning arrester in addition to others specified in IS/IEC standards: -

### 7.1 ACCEPTANCE TESTS

Acceptance test shall be as per cl. 9.2 of IEC 60099-4 ed 3 as mentioned below:

- a) Measurement of reference voltage test.
- b) Residual Voltage test on complete arrester.
- c) Partial Discharge Test
- d) Visual Inspection
- e) The resistive current drawn by the arrester at rated voltage
- f) Peel off test (removal of housing) shall be performed on 1 random samples from supplied lot to confirm cage design
- g) Measurement of power-frequency voltage on the arrester at the reference current
- h) Lightning impulse residual voltage on the arrester at nominal discharge current ( wet power frequency voltage test)

All acceptance tests shall be witnessed by the Purchaser's or his authorized



**Specification No:** ENG-EHV-1021

**Specification Name:** Technical Specification for 33KV Lightning Arrester (10 KA)

representative. The above mentioned test shall be made on the nearest lower whole number to the cube root of the number of arresters to be supplied as per IEC-60099-4.

## 7.2 ROUTINE TESTS

Routine test shall be as per cl. 9.1 of IEC 60099-4 ed 3 as mentioned below:

- a) Measurement of reference voltage test
- b) Residual Voltage Test on complete arrester
- c) Internal partial discharge test.
- d) The resistive current drawn by the arrester at rated voltage
- e) The power-frequency voltage

## 7.3 TYPE TESTS

- a) Insulation Withstand Test of Housing ( Lightning impulse – (cl. 8.2.8; IEC 60099-4 ed.3))
- b) Residual voltage test (cl. 8.3.2, cl. 8.3.3., cl 8.3.4; IEC 60099-4 ed.3)
- c) Long duration current impulse withstand test (cl. 8.4; IEC 60099-4 ed.3)
- d) Operating duty test (cl. 8.7; IEC 60099-4 ed.3)
- e) Short circuit test (Low (600A)/High Current (40kA) (cl. 8.10; IEC 60099-4 ed.3)
- f) Test for Bending moments (cl. 8.11; IEC 60099-4 ed.3)
- g) Weather aging test on full arrester 1000 hrs (cl. 8.12 and annexure-C; IEC 60099-4 ed.3)
- h) Partial Discharge Test (cl. 8.15; IEC 60099-4 ed.3)
- i) Wet power frequency voltage test (cl. 8.2.8; IEC 60099-4 ed.3)
- j) Power frequency (voltage VS time curve) (cl. 8.8; IEC 60099-4 ed.3)
- k) Test to verify repetitive charge transfer withstand (cl. 8.5; IEC 60099-4 ed.3)
- l) Heat Dissipation behavior verification of test sample (cl. 8.6; IEC 60099-4 ed.3)

## 8. TYPE TEST CERTIFICATES:

The Bidder shall furnish the type test certificates for the tests as mentioned above as per the corresponding standards. All the tests shall be conducted at **CPRI/ERDA** as per relevant standard. Type tests should have been conducted during the period not exceeding **5** years from the date of opening the bid. In the event of any discrepancy in the test reports, i.e. any test report not acceptable, same shall be carried out without any cost implication to TPCODL/TPWODL/TPNODL/TPSODL.

## 9. PRE-DISPATCH INSPECTION:

The material shall be subject to inspection by a duly authorized representative of the TPCODL/TPWODL/TPNODL/TPSODL. Inspection may be made at any stage of manufacture at the discretion of the purchaser and the equipment, if found unsatisfactory as to workmanship or material, the same is liable to rejection. Bidder shall grant free access to the places of manufacture to TPCODL/TPWODL/TPNODL/TPSODL's representatives at all times when the work is in progress. Inspection by the TPCODL/TPWODL/TPNODL/TPSODL or its authorized



**Specification No:** ENG-EHV-1021

**Specification Name:** Technical Specification for 33KV Lightning Arrester (10 KA)

representatives shall not relieve the bidder of his obligation of furnishing equipment in accordance with the specifications. Material shall be dispatched after specific MDCC (Material Dispatch Clearance Certificate) is issued by TPCODL/TPWODL/TPNODL/TPSODL.

Following documents shall be sent along with material.

- a) Test reports
- b) MDCC issued by TPCODL/TPWODL/TPNODL/TPSODL
- c) TPCODL/TPWODL/TPNODL/TPSODL Invoice in duplicate
- d) Packing list
- e) Drawings & catalogue
- f) Guarantee / Warrantee card
- g) Delivery Challan
- h) Other Documents (as applicable).

#### **10. INSPECTION AFTER RECEIPT AT STORE:**

The material received at TPCODL/TPWODL/TPNODL/TPSODL, Odisha store will be inspected for acceptance and shall be liable for rejection, if found different from the reports of the pre-dispatch inspection and one copy of the report shall be sent to Engineering department.

#### **11. GUARANTEE:**

Bidder shall stand guarantee towards design, materials, workmanship & quality of process/manufacturing of items under the contract for due and intended performance of the same, as an integrated product delivered under this contract. In the event any defect is found by the Company up to a period of 18 months from the date of commissioning or 24 months from the date of last supplies made under the contract, whichever is earlier, supplier shall be liable to undertake to replace/rectify such defects at his own costs. within mutually agreed timeframe, and to the entire satisfaction of the Company, failing which the Company will be at liberty to get it replaced/rectified at supplier's risks and costs and recover all such expenses plus the Company's own charges (@ 20% of expenses incurred), from the supplier or from the "Security cum Performance Deposit" as the case may be.

The bidder shall further be responsible for ' free replacement' for another period of THREE years from the end of gurantee period for any 'latent defects' if noticed by the company.

#### **12. PACKING AND TRANSPORT:**

Bidder shall ensure that all material covered by this specification shall be prepared for rail/road transport (local equipment) and be packed in such a manner as to protect it from damage in transit. The bidder shall provide instructions regarding handling and storage precautions to be taken at



**Specification No:** ENG-EHV-1021

**Specification Name:** Technical Specification for 33KV Lightning Arrester (10 KA)

site. The material should be packed in vertical position in individual box in such a way that the shape of rain shed does not get deformed during transportation and storage.

**13. TENDER SAMPLE:**

NA

**14. QUALITY CONTROL:**

The bidder shall submit QAP indicating the various stages of inspection, the tests and checks which will be carried out on the material of construction, components during manufacture and bought out items and fully assembled component and equipment after finishing. As part of the plan, a schedule for stage and final inspection within the parameters of the delivery schedule shall be furnished. The Purchaser's engineer or its nominated representative shall have free access to the manufacturer's/sub-supplier's works to carry out inspections.

**15. TESTING FACILITIES:**

Bidder shall have adequate in house testing facilities for carrying out all routine tests & acceptance tests as per relevant International / Indian standards.

**16. MANUFACTURING FACILITIES:**

The successful bidder shall submit the bar chart for various manufacturing activities clearly elaborating each stage, with quantity. This bar chart should be in line with the Quality assurance plan submitted with the offer.

The successful bidder will have to submit technical compliance document and drawing as per RC line items for getting approval before mass manufacturing.

Manufacturing shall start only after getting CAT-B approved drawings or as per intimation from TPCODL/TPWODL/TPNODL/TPSODL.

**17. SPARES, ACCESSORIES AND TOOLS**

Spares:Not applicable.

**Service Level Agreement**

- In case of any failure vendor shall report to site, within 24 hours of receipt of reporting of failure occurrence.
- Vendor shall provide detailed root cause analysis of the fault within 15 days from the date of occurrence of the fault/ failure.
- Any spare part replacement, testing and its commissioning to be done by the vendor only, without any price implication to the purchaser.

**18. DRAWINGS AND DOCUMENTS:**

Following drawings and documents shall be prepared based on



**Specification No:** ENG-EHV-1021

**Specification Name:** Technical Specification for 33KV Lightning Arrester (10 KA)

TPCODL/TPWODL/TPNODL/TPSODL specifications and statutory requirements and shall be submitted with the bid:

- a) Completely filled in Technical Particulars
- b) General description of the equipment and all components including brochures
- c) General arrangement drawing for Surge Arrestor (SA)
- d) Bill of material
- e) Experience List
- f) Type test certificates

**Drawings / documents to be submitted after the award of the contract are as under:**

**List of Drawings/Parameters to be submitted:**

S.No.	Description	For Approval	For Review Information	For Final Submission
1	Technical Particulars	✓	✓	✓
2	General Arrangement drawings including cross sectional view, mounting arrangement, Zno Block drawing, Surge Counter drawing, Name plate along with detailed Bill of Material)	✓	✓	✓
3	Terminal and Connection Drawing	✓	✓	✓
4	Manual/catalogue	✓	✓	✓
5	Installation/Commissioning Manuals	✓	✓	✓
6	Instruction for use	✓	✓	✓
7	Transport / Shipping dimension drawing	✓	✓	✓
8	QA & QC Plan	✓	✓	✓
9	Routine, Acceptance and Type Test Certificates	✓	✓	✓

**Additional Documents to be submitted:**

- a) List of raw materials as well as bought out accessories and the names of sub-suppliers selected from those furnished along with offer.
- b) Type test certificates of the raw materials and bought out accessories.
- c) The successful Bidder shall submit the routine test certificates of bought out accessories and central excise passes for raw material at the time of routine testing.

All the documents & drawings shall be in English language.

After the receipt of the order, the successful bidder will be required to furnish all relevant drawings/parameters/calculation to TPCODL/TPWODL/TPNODL/TPSODL for approval.

**Instruction Manuals:**

Bidder shall furnish softcopies of nicely bound manuals (In English language) covering erection and maintenance instructions and all relevant information and drawings



**Specification No:** ENG-EHV-1021

**Specification Name:** Technical Specification for 33KV Lightning Arrester (10 KA)

pertaining to the main equipment as well as auxiliary devices.

**19. SCHEDULE- "A" GUARANTEED TECHNICAL PARTICULARS:**

GENERAL TECHNICAL PARTICULARS			
SL. NO.	TECHNICAL PARTICULARS	SM Class (Class-III)	SL Class (Class-II)
1	Installation		
2	Reference standards (Latest Amend.)		
3	Arrester Type and Housing		
4	Normal System Voltage		
5	Highest System Voltage		
6	Rated Frequency		
7	Maximum Continuous Operating Voltage (M.C.O.V)		
8	Arrester Rating		
9	<b>Discharge Current</b>		
a	Nominal Discharge Current		
b	Switching impulse discharge current		
10	Short Circuit rating		
11	<b>Voltage Withstand on Arrester Housing</b>		
a	Standard rated short duration Power Frequency withstand Voltage (Dry/Wet) as per IS:2165		
b	Standard rated Lightning Impulse withstand Voltage (Peak in kV)		
12	Lightning Impulse Protection Level (at 10kA)		
13	<b>Long Duration Current</b>		
a	Peak Current		
b	Virtual duration of Peak T		
14	High Current impulse Operating Duty		
15	Creepage Distance of Arrester Housing		
16	Partial Discharge at 1.05 times M.C.O. V		
17	Energy Absorption capacity (KJ/KV)		
18	Repetitive charge transfer withstand (coloumbs),Qrs		
19	<b>Temporary over voltage (TOV)</b>		
a	1 sec		
b	10 sec		
20	<b>Maximum Lightning Impulse Residual voltage with 8/20 microsecond wave</b>		



	<b>Specification No:</b> ENG-EHV-1021  <b>Specification Name:</b> Technical Specification for 33KV Lightning Arrester (10 KA)
---	---

a	at 5kA		
b	at 10kA		
c	at 20kA		
21	Maximum switching current impulse residual voltage in kVP at 500 A		
22	Max. Cantilever Strength		
23	Total height of the arrester		
24	Total weight of the arrester		
25	No. of Metal oxide blocks in arrester		
26	Rating of individual ZnO blocks used for assembly		
27	Power Losses of the Arrester in watt		
28	Type of Mounting		
29	Material of Insulating base		
30	Insulating Terminal Cap	Polyolefin	
31	Material of Nuts and bolts	Stainless Steel	

**20. SCHEDULE “B” DEVIATIONS:**

**(TO BE ENCLOSED WITH TECHNICAL BID)**

All deviations from this specification shall be set out by the Bidders, clause by Clause in this schedule. Unless specifically mentioned in this Schedule, the tender shall be deemed to confirm the purchaser's specifications:

SL. No	Clause No.	Details of deviation with justifications

We confirm that there are no deviations apart from those detailed above.

Seal of the Company:

Signature

Designation



## **CONTENTS**

1. SCOPE
2. APPLICABLE STANDARDS
3. CLIMATIC CONDITIONS OF THE INSTALLATION
4. GENERAL TECHNICAL REQUIREMENTS
5. GENERAL CONSTRUCTIONS
6. NAME PLATE AND MARKING
7. TESTS
8. TYPE TEST CERTIFICATES
9. PRE-DESPATCH INSPECTION
10. INSPECTION AFTER RECEIPT AT STORES
11. GUARANTEE
12. PACKING
13. TENDER SAMPLE
14. QUALITY CONTROL
15. MINIMUM TESTING FACILITIES
16. MANUFACTURING ACTIVITIES
17. SPARES, ACCESSORIES AND TOOLS
18. DRAWINGS AND DOCUMENTS
19. SCHEDULE OF DEVIATIONS
20. GURANTEED TECHNICAL PARTICULARS

## 1.0 SCOPE

This specification covers the manufacture testing at works, supply and delivery of Mid Span Joint for ACSR Dog, Wolf, Panther & Zebra Conductor as per the following technical specification and the enclosed data sheet.

## 2.0 APPLICABLE STANDARDS

The equipment covered by this specification shall unless otherwise stated, be designed, manufactured and tested in accordance with the latest editions of the following Indian, International Standards and shall conform to the regulations of the local authorities:

IS 2121 (Part 2)	Conductors and earth wire accessories for overhead power lines: Part 2 Mid span joints and repair sleeves for conductors.
IS 2633:1986	Methods for testing uniformity of coating of zinc coated articles.
IS 4826:1979	Hot dipped galvanized coatings on round steel wires.
IS 2629	Recommended practice for hot-dip galvanizing of iron and steel.

## 3.0 CLIMATIC CONDITIONS OF THE INSTALLATION

SL.NO.	CONDITONS	VALUES
1	Max. altitude above sea level	1200 m
2	Max. Ambient Temperature	50 °C
3	Max. Daily average ambient temp	35 °C
4	Min Ambient Temp	0 °C
5	Maximum temperature attainable by an object exposed to sun	60 °C
6	Maximum Humidity	95%
7	Minimum Humidity	10%
8	Average No. of thunderstorm days per annum	70
9	Average Annual Rainfall	150 cm
10	Average No. of rainy days per annum	120
11	Thermal Resistivity of soil	150 Deg. Ccm/W
12	Wind Pressure	126 kg/sq. m up to an elevation of 10 meter.
14	Earthquakes of intensity in horizontal direction	equivalent to seismic acceleration of 0.3g

15	Earthquakes of intensity in vertical direction	equivalent to seismic acceleration of 0.15g
16	Wind velocity	300 km/hr.

Environmentally, some of the regions, where the work will take place includes coastal areas, subject to high relative humidity, which can give rise to condensation. Onshore winds will frequently be salt laden. On occasions, the combination of salt and condensation may create pollution conditions for outdoor insulators. Some places are in heavily industrial polluted areas. Therefore, Outdoor material and equipment shall be designed and protected for use in exposed, heavily polluted, salty, corrosive and humid coastal atmosphere. The design of equipment and accessories shall be suitable to withstand seismic forces as men.

#### 4.0 GENERAL TECHNICAL REQUIREMENTS

Sr.No	Description	Units	Requirement			
			Dog	Wolf	Panther	Zebra
1	Suitable for(conductor size):	Sq. mm	100	150	232	400
2	Minimum failing /Slipping load	Kg	95% of ultimate strength of conductor	95% of ultimate strength of conductor	95% of ultimate strength of conductor	95% of ultimate strength of conductor
3	Material					
4	Outer Sleeve		Extended Aluminum tube of 99.5% purity	Extended Aluminum tube of 99.5% purity	Extended Aluminum tube of 99.5% purity	Extended Aluminum tube of 99.5% purity
5	Inner Sleeve		High strength steel	High strength steel	High strength steel	High strength steel
6	Electrical Resistance At20 Deg C	Ohm	75% of measured resistance of equivalent length of conductor	75% of measured resistance of equivalent length of conductor	75% of measured resistance of equivalent length of conductor	75% of measured resistance of equivalent length of conductor

7	Ferrous Parts		Hot dip galvanized	Hot dip galvanized	Hot dip galvanized	Hot dip galvanized
8	Outside diameter of sleeves					
8.1	Aluminum	Mm	30	33	38	43
8.2	Steel	mm	12.2	15.2	18	19.2
9	Dia. of sleeves Across Flat (After compression)					
9.1	Aluminum	mm	25	28	32	36
9.2	Steel	mm	10.1	12.2	15.1	16.1
10	Length of sleeve					
10.1	Aluminum	mm	510	560	610	712
10.2	Steel	mm	159	178	204	240
11	Weight of Sleeve (Approx.)					
11.1	Aluminum	Kg	To be Provided by bidder	To be Provided by bidder	To be Provided by bidder	To be Provided by bidder
11.2	Steel	Kg	To be Provided by bidder	To be Provided by bidder	To be Provided by bidder	To be Provided by bidder
12	Breaking strength of Mid-span joint	kN	Not less than 95% of ultimate tensile strength of conductor	Not less than 95% of ultimate tensile strength of conductor	Not less than 95% of ultimate tensile strength of conductor	Not less than 95% of ultimate tensile strength of conductor
13	Min. Conductivity of compression joint	Amps	350	450	550	750
14	Galvanizing					
14.1	Minimum weight of zinc coating per sq. m of uncoated wire surface	gms	610	610	610	610

## 5.0 GENERAL CONSTRUCTION

Mid span compression joint shall be used for joining two lengths of conductors. The joint shall have a resistivity less than 75% of the receptivity of equivalent length of conductor. The joint shall not permit slipping off, damage to or failure of the complete conductor or any part thereof at a load less than 95% of the ultimate tensile strength of the conductor.

Compression type mid-span straight joints offered should be suitable for making joints in the ACSR conductor. The joints offered should conform to IS: 2121/1981 (with latest amendment).

The joint shall be so designed, that when installed, no air space is left within the finished joint. The joint shall have conductivity as specified above but the mechanical strength shall not be less than 95% of the ultimate tensile strength of the conductor.

The aluminum sleeve shall be made from extruded aluminum tube of aluminum of purity not less than 99.5%. The steel sleeve shall be of high strength steel.

The joint shall be made of steel and aluminum sleeves for jointing the steel core and aluminum wires respectively. The steel sleeve should not crack or fail during compression. The Brinell Hardness of steel sleeve shall not exceed 200. The steel sleeve shall be hot dip galvanized. Tapered aluminum filler plugs shall also be provided on the line of demarcation between compression and non-compression zone.

ACSR Full Tension Compression Mid Span Joints are manufactured from an Aluminium outer extrusion, and an inner steel tubular core. The two-piece design ensures a design strength equivalent to the conductor onto which the fitting is applied.

Each fitting is manufactured with internal and external tapers, to eliminate stresses associated with compression, and reduce corona discharge.

**DIAGRAM OF MID SPAN JOINT IN BELOW:**

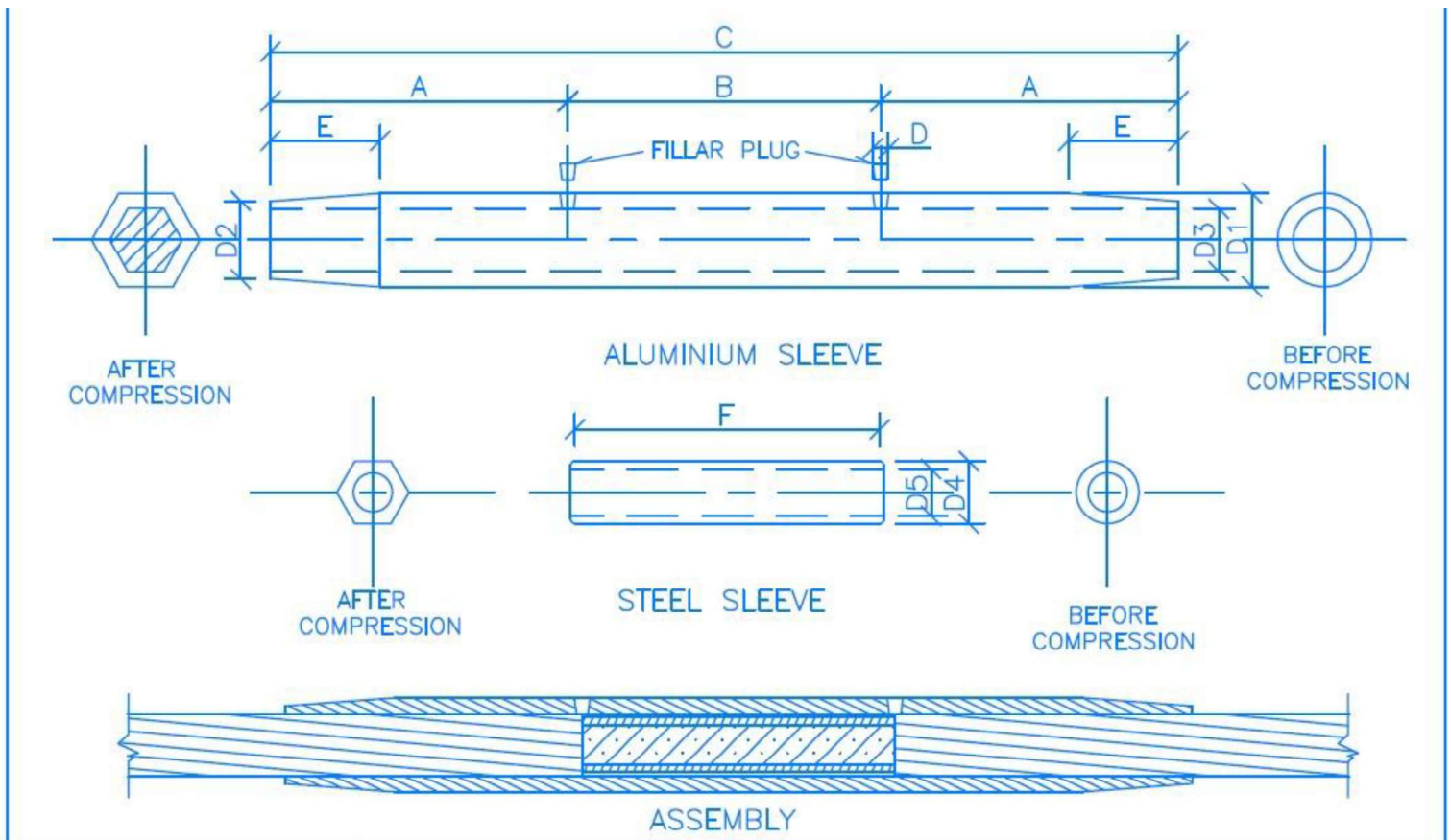

**6.0 NAME PLATE AND MARKING**

The Mid span joint shall be marked with the following:

- Reference to the Standards.
- Manufacturer's name
- Size and the type of conductor mid span joint
- Net weight of the Mid span joint (in kg)
- Gross weight of the Mid span joint (in kg)
- Length of the Mid span joint (in mm).
- Marking of PO.
- Country of manufacture.
- Year of manufacture.
- ISI Certification mark.

## 7.0 TESTS

All routine, acceptance & type tests for Mid Span joint shall be carried out in accordance with the relevant IS/IEC. All routine/acceptance tests shall be witnessed by the purchaser/his authorized representative.

Following tests shall be necessarily conducted on the MS joint as specified in the IS standards:

**7.1** The following Routine / **Acceptance tests** shall be carried out on MS joints as per IS: 2121 (part-II) / 1981 (with latest amendment).

- a) Visual examination.
- b) Dimensional verification.
- c) Failing load test.
- d) Galvanizing test.
- e) Electrical resistance test.

## 7.2 Type Tests

- a) Visual examination.
- b) Verification of dimension
- c) Failing load test
- d) Electrical resistance test.
- e) Heating cycle test.
- f) Galvanizing test.
- g) Radio interference voltage test
- h) Corona test

## 8.0 TYPE TEST CERTIFICATES

The bidder shall furnish the type test certificates of the mid span joint for the tests as mentioned as above as per the corresponding standards. All the tests shall be conducted at **CPRI/ERDA/Approved Labs by TATA ODISHA DISCOMs** as per the relevant standards. Type test should have been conducted in certified Test laboratories during the period not exceeding 5 years from the date of opening the bid. In the event of any discrepancy in the test reports i.e. any test report not acceptable or any/all type tests (including additional type tests, if any) not carried out, same shall be carried out without any cost implication to TPCODL/TPNODL/TPSODL/TPWODL.



## 9.0 PRE-DESPATCH INSPECTION

The Material shall be subject to inspection by a duly authorized representative of the TPWODL. The inspection shall be carried out as per TPCODL/TPNODL/TPSODL/TPWODL specification and relevant IS standards. Inspection may be made at any stage of manufacture at the discretion of the purchaser and the equipment, if found unsatisfactory as to workmanship or material, the same is liable to rejection. Bidder shall grant free access to the places of manufacture to TPCODL/TPNODL/TPSODL/TPWODL's representatives at all times when the work is in progress. Inspection by the TPCODL/TPNODL/TPSODL/TPWODL or its authorized representatives shall not relieve the bidder of his obligation of furnishing equipment in accordance with the specifications. Material shall be dispatched after specific MDCC (Material Dispatch Clearance Certificate) is issued by TPCODL/TPNODL/TPSODL/TPWODL.

Following documents shall be sent along with material:

- a) Test reports
- b) MDCC issued by TPCODL/TPNODL/TPSODL/TPWODL
- c) Invoice in duplicate
- d) Packing list
- e) Drawings & catalogue
- f) Guarantee / Warrantee card
- g) Delivery Challan
- h) Other Documents (as applicable)

## 10.0 INSPECTION AFTER RECEIPT AT STORES

The material received at TPCODL/TPNODL/TPSODL/TPWODL store will be inspected for acceptance and shall be liable for rejection, if found different from the reports of the pre-dispatch inspection and one copy of the report shall be sent to contracts & Engineering department.

## 11.0 GUARANTEE

Bidder shall stand guarantee towards design, materials, workmanship & quality of process / manufacturing of items under this contract for due and intended performance of the same, as an integrated product delivered under this contract. In the event any defect is found by the Purchaser up to a period of at least 12 months from the date of commissioning or 24 months from the date of last supplies made under the contract whichever is later, (the time scale of 12/24 months could be enhanced subject to mutual agreements). Bidder shall be liable to



**Specification Name:**Specification for- Mid Span compression joint  
(ACSR conductors)

undertake to replace/rectify such defects at its own costs, within mutually agreed time frame, and to the entire satisfaction of the Purchaser, failing which the Purchaser will be at liberty to get it replaced/rectified at Bidder's risks and

costs and recover all such expenses plus the Purchaser's own charges (@ 20% of expenses incurred), from the Bidder or from the "Security cum Performance Deposit" as the case may be.

Bidder shall further be responsible for 'free replacement' for another period of THREE years from the end of the guarantee period for any 'Latent Defects' if noticed and reported by the Purchaser.

## 12.0 PACKING

The mid span shall be supplied in the packing box. of standard dimension as per relevant IS.

## 13.0 TENDER SAMPLE

Bidder shall submit the sample of material with the offer (in case of first supply to TPCODL/TPNODL/TPSODL/TPWODL).

## 14.0 QUALITY CONTROL

The bidder shall submit with the offer Quality assurance plan indicating the various stages of inspection, the tests and checks which will be carried out on the material of construction, components during manufacture and bought out items and fully assembled component and equipment after finishing. As part of the plan, a schedule for stage and final inspection within the parameters of the delivery schedule shall be furnished. The Purchaser's engineer or its nominated representative shall have free access to the manufacturer's/sub-supplier's works to carry out inspections.

### Rejection and Retest

During inspection if any one of the test pieces first selected fail to pass the tests, three further samples from the same batch shall be selected as per IS, one of which shall be from the length from which the original test sample was taken, unless that length has been withdrawn by the supplier.

If all of the three test pieces from these additional samples satisfy the requirements of the tests, the batch represented by these samples shall be deemed to comply with the standard.

In case, the test



**Specification No:** [ENG-EHV-1032](#)

**Specification Name:**

Specification for- Mid Span compression joint  
(ACSR conductors)

pieces from any of the three additional samples fail, the batch represented shall be deemed not to comply with the standard.

#### **15.0 MINIMUM TESTING FACILITIES**

Bidder shall have adequate in-house testing facilities for carrying out all routine tests & acceptance tests as per relevant International/Indian standards.

#### **16.0 MANUFACTURING ACTIVITIES**

The successful bidder will have to submit the bar chart for various manufacturing activities clearly elaborating each stage, with quantity. This bar chart should be in line with the Quality assurance plan submitted with the offer. This bar chart will have to be submitted within 15 days from the release of the order.

#### **17.0 SPARES, ACCESSORIES AND TOOLS**

The bidder shall provide a list of complete set of accessories and tools required for erection and maintenance of mid span joint along with the installation procedure.

#### **18.0 DRAWINGS AND DOCUMENTS**

Following documents shall be prepared based on TPCODL/TPNODL/TPSODL/TPWODL specifications and statutory requirements with complete BOM and shall be submitted with the bid:

Completely filled in Technical Particulars.

General description of the equipment and all components including brochures.

Type test Certificates

Experience List.

After the award of the contract, four (4) copies of the drawings, drawn to scale, describing the equipment in detail shall be forwarded for approval and shall subsequently provide four (4) complete sets of final drawings, one of which shall be auto positive suitable for reproduction, before the dispatch of the equipment. Soft copy (Compact Disk CD) of all the drawing, GTP, test certificates shall be submitted after the final approval of the same to the purchaser.

Following Drawings/Documents shall be submitted after the award of the contract:

S. No	Description	For Approval	For Review Information	Final Submission
1	Technical Parameters	√		√
2	Manual/Catalogues/drawings for all components.		√	
3	Technical details and test certificates of the Mid Span Joint.		√	√
4	Cross sectional area of the Mid Span Joint.		√	√
5	Installation Instructions		√	√
6	Instructions for use		√	√
7	Transport/shipping dimension drawing		√	√
8	QA & QC Plan	√	√	√
9	Routine, Acceptance and Type test Certificates	√	√	√

All the Documents and Drawings shall be in English Language.

**Instruction Manuals:** Bidder shall furnish two (2) soft copies (CD) and four (4) hard copies of nicely bound manual (in English Language) covering erection and maintenance instructions and all relevant information pertaining to the main equipment as well as auxiliary devices.

### 19.0 GUARANTEED TECHNICAL PARTICULARS

Sr.No	Description	Units	Requirement			
			Dog	Wolf	Panther	Zebra
1	Suitable for (conductor size):	Sq. mm				
2	Minimum failing /Slipping load	Kg				
3	Material					

4	Outer Sleeve					
5	Inner Sleeve					
6	Electrical Resistance At20 Deg C	Ohm				
7	Ferrous Parts					
8	Outside diameter of sleeves					
8.1	Aluminum	Mm				
8.2	Steel	mm				
9	Dia. of sleeves Across Flat (After compression)					
9.1	Aluminum	mm				
9.2	Steel	mm				
10	Length of sleeve					
10.1	Aluminum	mm				
10.2	Steel	mm				
11	Weight of Sleeve (Approx.)					
11.1	Aluminum	Kg				
11.2	Steel	Kg				
12	Breaking strength of Mid-span joint	kN				
13	Min. Conductivity of compression joint	Amp s				
14	Galvanizing					
14.1	Minimum weightof zinc coating per sq. m of uncoated wire surface	gms				



**Specification No:** [ENG-EHV-1032](#)

**Specification Name:**

Specification for- Mid Span compression joint  
(ACSR conductors)

## 20.0 SCHEDULE OF DEVIATIONS

### (TO BE ENCLOSED WITH TECHNICAL BID)

All deviations from this specification shall be set out by the Bidders, clause by Clause in this schedule. Unless specifically mentioned in this Schedule, the tender shall be deemed to confirm the purchaser's specifications:

S. No	Clause No.	Details of deviation with justifications

We confirm that there are no deviations apart from those detailed above. Seal of the Company:

Signature

Designation

**CONTENTS**

1. SCOPE
2. APPLICABLE STANDARDS
3. CLIMATIC CONDITIONS OF THE INSTALLATION
4. GENERAL TECHNICAL REQUIREMENTS
5. GENERAL CONSTRUCTIONS
6. MARKING
7. TESTS
8. TYPE TEST CERTIFICATES
9. PRE-DISPATCH INSPECTION
10. INSPECTION AFTER RECEIPT AT STORES
11. GUARANTEE
12. PACKING
13. TENDER SAMPLE
14. QUALITY CONTROL
15. TESTING FACILITIES
16. MANUFACTURING ACTIVITIES
17. SPARES, ACCESSORIES AND TOOLS
18. DRAWINGS AND DOCUMENTS
19. SCHEDULE "A" GUARANTEED TECHNICAL PARTICULARS
20. SCHEDULE "B" DEVIATIONS

**1. SCOPE:**

This specification covers the design, manufacture, testing and supply of 33kV GI V Cross Arm to be used in Structures. Scope also includes transportation & unloading at store / site.

**2. APPLICABLE STANDARDS:**

The equipment covered by this specification shall unless otherwise stated, be designed, manufactured and tested in accordance with the latest editions of the following Indian, International Standards and shall conform to the regulations of the local authorities:

IS 2062	Hot Rolled Medium and High Tensile Structural Steel
IS 1852	Rolling and Cutting Tolerances for Hot Rolled Steel products
IS 2633	Methods for testing uniformity of coating of zinc coated articles
IS 4759	Hot-dip zinc coatings on structural steel and other allied products
IS 6745	Method for determination of mass of zinc coating on zinc coated iron and steel articles

**3. CLIMATIC CONDITIONS OF THE INSTALLATION:**

SL.NO.	CONDITONS	VALUES
1	Max. altitude above sea level	1200m
2	Max. Ambient Temperature	50 °C
3	Max. Daily average ambient temp	35 °C
4	Min Ambient Temp	0 °C
5	Maximum temperature attainable by an object exposed to sun	60 °C
6	Maximum Humidity	95%
7	Minimum Humidity	10%
8	Average No. of thunderstorm days per annum	70
9	Average Annual Rainfall	150 cm
10	Average No. of rainy days per annum	120
11	Thermal Resistivity of soil	150 Deg. Ccm/W
12	Wind Pressure	126 kg/sq. m up to an elevation of 10 meter.

SL.NO.	CONDITIONS	VALUES
14	Earthquakes of intensity in horizontal direction	equivalent to seismic acceleration of 0.3g
15	Earthquakes of intensity in vertical direction	equivalent to seismic acceleration of 0.15g
16	Wind velocity	300 km/hr.

TPCODL/TPNODL/TPSODL/ TPWODL service area **has heavy saline conditions along the coast and High cyclonic Intensity winds with speed up to 300 Km ph.** The atmosphere is generally laden with mild acid, dust in suspension during the dry months, and is subjected to fog in cold months.

#### 4. GENERAL TECHNICAL REQUIREMENTS:

SL. NO.	TECHNICAL PARTICULARS	DESIRED VALUE
1	Materials	100X50X5 mm Channel , 65X65X6 mm Angle
2	Galvanisation process	Hot-Dip Galvanized
3	Relevant Standard	IS: 2062, IS: 2633, IS: 2629, TPCO-OTH-010.
4	Make	SAIL, JINDAL, RINL & TATA (Billet with re rolling not allowed)
5	Weight of Cross Arm	20 KG (Approx.)
6	Grade of Steel	E 250 A
7	Minimum Tensile Strength	410 N/mm <sup>2</sup>
8	Yield Stress	250 N/mm <sup>2</sup>
9	Percentage Elongation (Min.) at Gauge Length	23%
10	Bend Test (Internal Dia)	Min-2t
11	Mass of Zinc Coating	Min 705 gm/m <sup>2</sup>
12	Zinc Coating Thickness	Min 100 micron (6 Dip)
13	Chemical composition	Grade: E 250 A (As per IS: 2062)
14	Tolerance	As per IS 1852 latest amendment

#### 5. GENERAL CONSTRUCTION:

The Chemical composition and Physical properties of the finished material shall be as per the equivalent standards. Chemical Composition and Physical Properties shall conforming to IS: 2062. The approved makes are SAIL, JINDAL, RINL & TATA (Billet with re rolling not allowed).



## 5.1 CHEMICAL COMPOSITION

Chemical composition for 250 A Grade

- a) C - 0.23% Max
- b) Mn - 1.5% Max
- c) S - 0.045% Max
- d) P - 0.045% Max
- e) SI - 0.40% Max
- f) CE (Carbon Equivalent)- 0.42%

## 5.2 Galvanization:

All 33kV V Cross Arms shall be hot dip galvanized, are as following:

- a) All galvanizing shall be carried out by the hot dip process, in accordance with Specification IS 2629.
- b) The zinc coating (Min 705 gms per sq.mt / 100 Micron, 6 Dips) shall be smooth, continuous and uniform. It shall be free from acid spot and shall not scale, blister or be removable by handling or packing.
- c) There shall be no impurities in the zinc or additives to the galvanic bath which could have a detrimental effect on the durability of the zinc coating. Purity of zinc shall be Zn 99.95% or better.
- d) In the event of damage to the galvanizing the method used for repair shall be subject to the approval of the Engineer in Charge or that of his representative. Repair of galvanization at site will not be permitted in any situation.
- e) Partial immersion of the work shall not be permitted and the galvanizing tank must therefore be sufficiently large to permit galvanizing to be carried out by one immersion.
- f) After galvanizing no drilling or welding shall be performed on the galvanized parts. To avoid the formation of white rust galvanized materials shall be stacked during transport and stored in such a manner as to permit adequate ventilation. Sodium dichromate treatment shall be provided to avoid formation of white rust after hot dip galvanization. The galvanized steel shall be subjected to test as per IS-2633.
- g) Quality of Hot Dip Galvanization should comply with IS 2629, ISO 1461 & should be guaranteed for any type of damage due to harsh climatic condition for 5 Years. These V Cross Arms are to be used in coastal areas of Odisha where climate is hot, humid & saline. These areas are prone to flood & frequent rainfall.

**6. MARKING:**

Following distinct non-erasable embossing is to be made on each Channel and Angles to be supplied to TPCODL/TPWODL/TPNODL/TPSODL under this Tender.

- a) Manufacturer Name/ Trade Mark

Engraved Marking (Punching before galvanization)

- a) "TPCODL/TPWODL/TPNODL/TPSODL"  
b) Year of manufacturing  
c) PO Number

**7. TESTS:**

The bidder shall be required to submit complete set of the following test reports along with the offer:

**7.1 ACCEPTANCE TESTS**

- i) Chemical Composition  
ii) Mechanical Properties  
iii) Dimension Test & Weight (kg/M) Visual Examination,  
iv) Test in respect of Hot Dip Galvanization i.e. Thickness of zinc coating in microns

**7.2 ROUTINE TESTS**

Same as Acceptance Test

**7.3 TYPE TESTS**

- i) Chemical Composition  
ii) Mechanical Properties  
iii) Test in respect of Hot Dip Galvanization i.e. thickness of zinc coating in microns

**8. TYPE TEST CERTIFICATES:**

The Bidder shall furnish the type test certificates for the tests as mentioned above as per the corresponding standards. All the tests shall be conducted at **CPRI/ERDA/Other Govt. Lab** as per relevant IS. However, TPCODL/ TPWODL/ TPNODL/ TPSODL. TATA-POWER reserves the right to allow any other NABL accredited/ Govt. lab report under exceptional circumstances after due diligence/ scrutiny by DISCOM. Type tests should have been conducted during the period not exceeding 5 years from the date of opening the bid. In the event of any discrepancy in the test reports, i.e. any test report not acceptable, same shall be carried out without any cost implication to TPCODL/ TPWODL/ TPNODL/ TPSODL.

**9. PRE-DISPATCH INSPECTION:**

The material shall be subject to inspection by a duly authorized representative of the TPCODL/TPWODL/TPNODL/TPSODL. Inspection may be made at any stage of manufacture at

the discretion of the purchaser and the equipment, if found unsatisfactory as to workmanship or material, the same is liable to rejection. Bidder shall grant free access to the places of manufacture to TPCODL/TPWODL/TPNODL/TPSODL's representatives at all times when the work is in progress. Inspection by the TPCODL/TPWODL/TPNODL/TPSODL or its authorized representatives shall not relieve the bidder of his obligation of furnishing equipment in accordance with the specifications. Material shall be dispatched after specific MDCC (Material Dispatch Clearance Certificate) is issued by TPCODL/TPWODL/TPNODL/TPSODL.

Following documents shall be sent along with material.

- a) Test reports
- b) MDCC issued by TPCODL/TPWODL/TPNODL/TPSODL
- c) TPCODL/TPWODL/TPNODL/TPSODL Invoice in duplicate
- d) Packing list
- e) Drawings & catalogue
- f) Guarantee / Warrantee card
- g) Delivery Challan
- h) Other Documents (as applicable).

**10. INSPECTION AFTER RECEIPT AT STORE:**

The material received at TPCODL/TPWODL/TPNODL/TPSODL, Odisha store will be inspected for acceptance and shall be liable for rejection, if found different from the reports of the pre-dispatch inspection and one copy of the report shall be sent to Engineering department.

**11. GUARANTEE:**

Bidder shall stand guarantee towards design, materials, workmanship & quality of process/manufacturing of items under the contract for due and intended performance of the same, as an integrated product delivered under this contract. In the event any defect is found by the Company up to a period of 12 months from the date of commissioning or 24 months from the date of last supplies made under the contract, whichever is earlier, supplier shall be liable to undertake to replace/rectify such defects at his own costs. within mutually agreed timeframe, and to the entire satisfaction of the Company, failing which the Company will be at liberty to get it replaced/rectified at supplier's risks and costs and recover all such expenses plus the Company's own charges (@ 20% of expenses incurred), from the supplier or from the "Security cum Performance Deposit" as the case may be.

Galvanization Guarantee- Quality of Hot Dip Galvanization should be guaranteed for any type of damage due to harsh climatic condition for 5 Years.

**12. PACKING:**

Supplier shall ensure that all material covered by this specification shall be prepared for rail/road transport (local equipment) and be packed in such a manner as to protect it from damage in transit. The bidder shall provide instructions regarding handling and storage precautions to be taken at site.

**13. TENDER SAMPLE:**

The Bidder shall provide 1 no. sample of the product. The product will be accepted only if it meets all specifications as defined in the document.

**14. QUALITY CONTROL:**

The bidder shall submit QAP indicating the various stages of inspection, the tests and checks which will be carried out on the material of construction, components during manufacture and bought out items and fully assembled component and equipment after finishing. As part of the plan, a schedule for stage and final inspection within the parameters of the delivery schedule shall be furnished. The Purchaser's engineer or its nominated representative shall have free access to the manufacturer's/sub-supplier's works to carry out inspections.

**15. TESTING FACILITIES:**

Supplier/ Manufacturer shall have adequate in house testing facilities for carrying out all routine tests & acceptance tests as per relevant Indian standards.

**16. MANUFACTURING FACILITIES:**

The bidder shall get the approved drawing and GTP before start of manufacturing activity. The successful bidder will have to submit details of the offered design & components for approval as per specification. CAT-A/CAT-B is mandatory to start manufacturing.

**17. SPARES, ACCESSORIES AND TOOLS**

Not applicable.

**18. DRAWINGS AND DOCUMENTS:**

Following drawings and documents shall be submitted in line with the requirement of Tender specifications:

- a) Completely filled—in clause wise compliance of the specification
- b) Schedule “B” Deviations
- c) Work Experience details
- d) Type test certificates.
- e) Drawing 1 set of Hard Copy & Soft copy PDF File containing complete information about manufacturing.

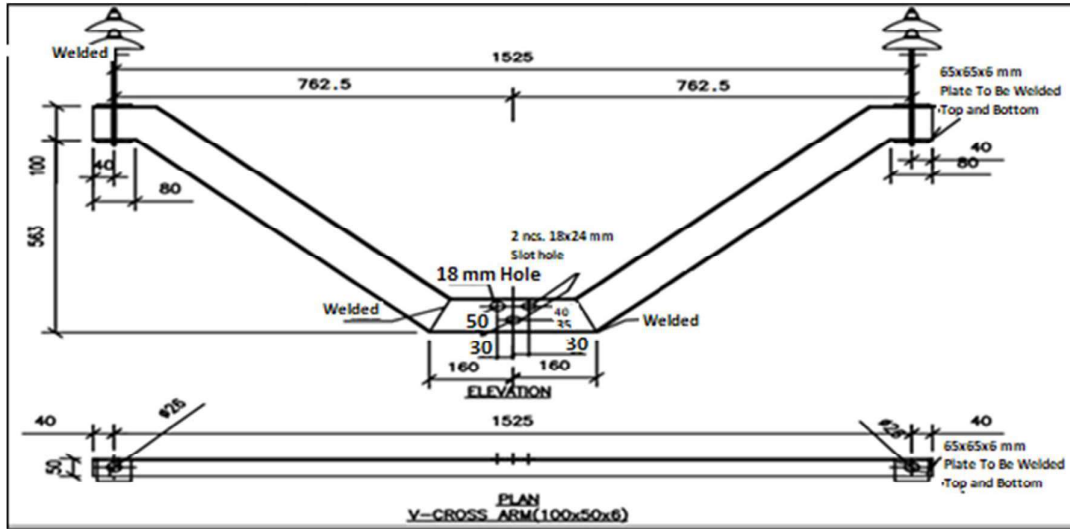

OPTION1:- Arrangement in WPB Pole

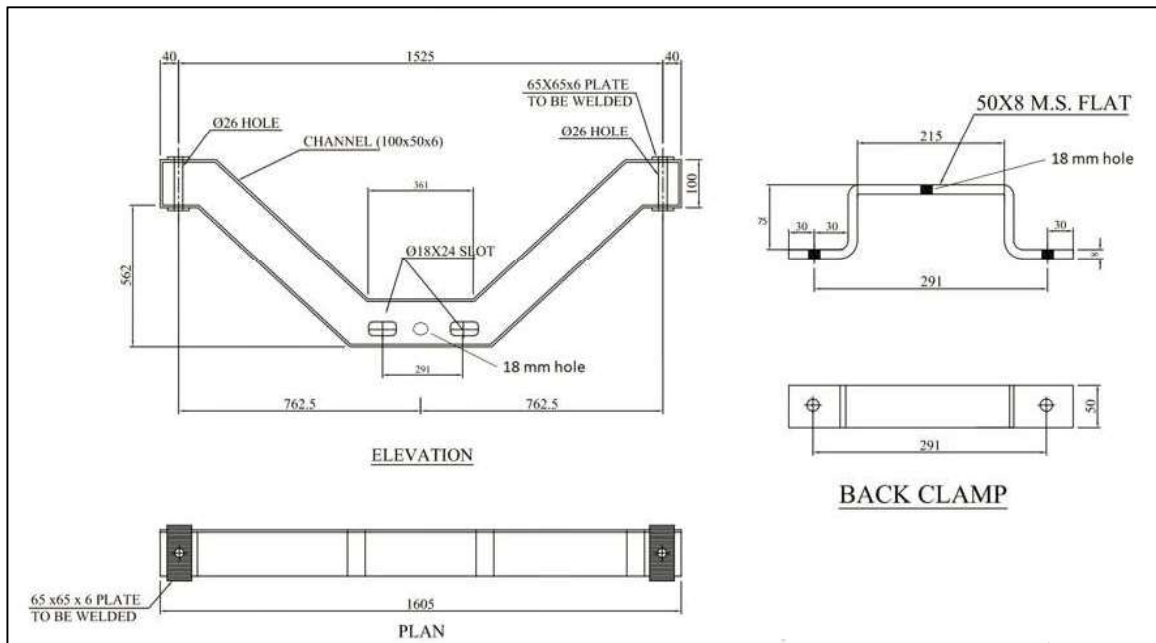

OPTION2:- Arrangement in 9 Mtr. PSC Pole

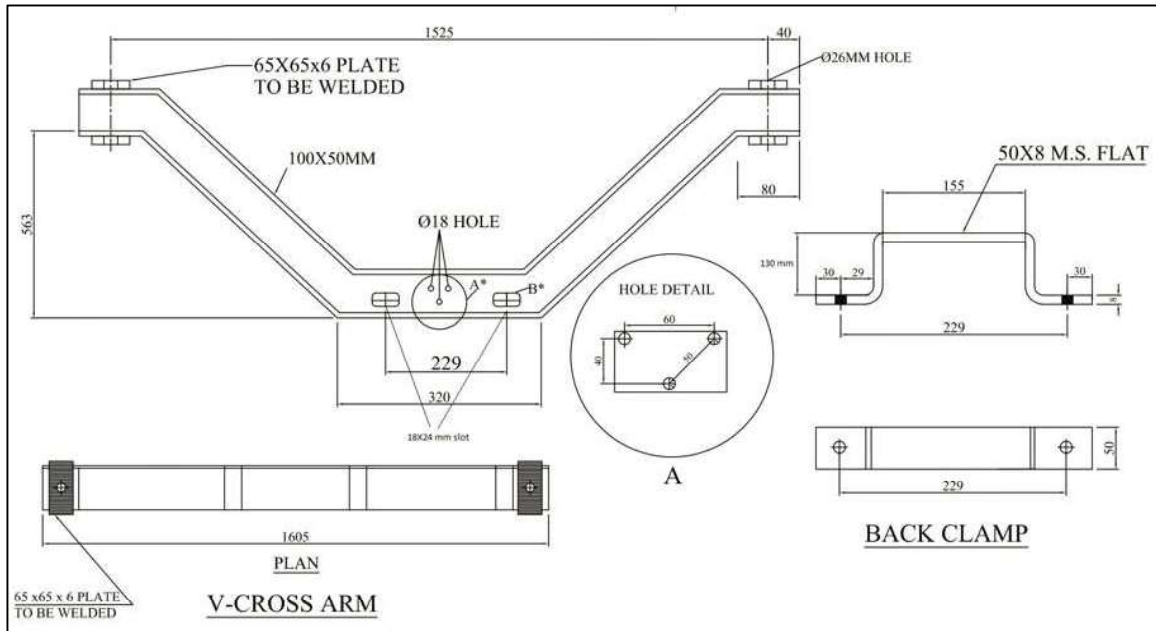

OPTION 3:- Arrangement in RSJ Pole

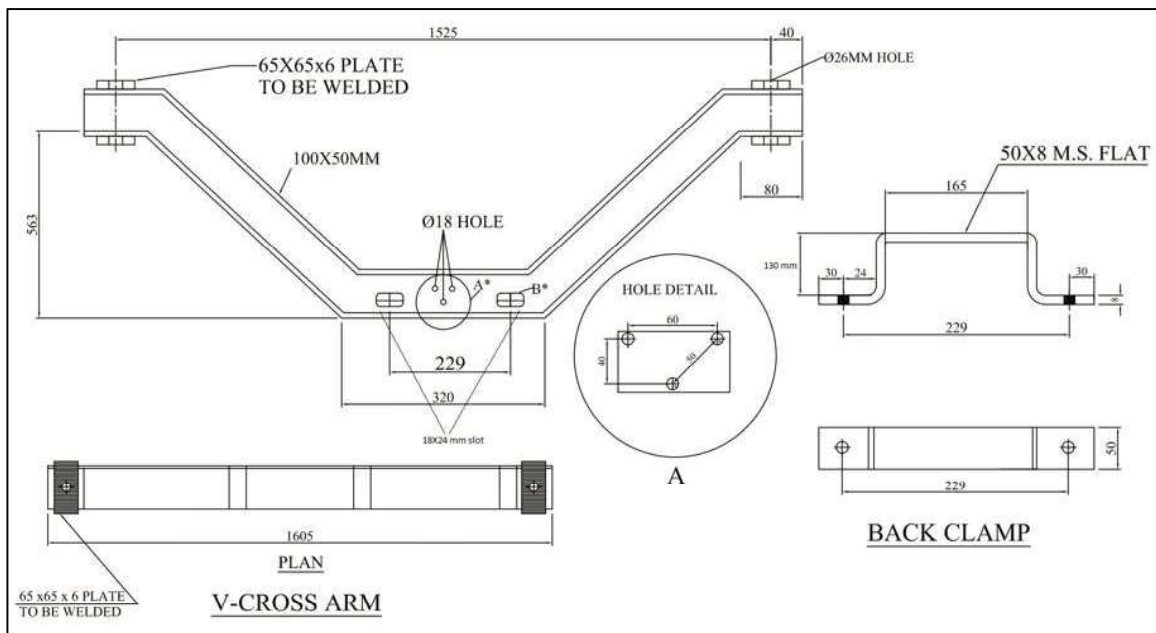

OPTION 4:- Arrangement in WPB Pole

**Note:- The drawing is for tender purpose only and indicative in nature & will be finalized during detailed engineering**

**19. SCHEDULE- "A" GUARANTEED TECHNICAL PARTICULARS:**

Bidder to submit completely clause wise compliance of this specification.

**20. SCHEDULE "B" DEVIATIONS:**

**(TO BE ENCLOSED WITH TECHNICAL BID)**

All deviations from this specification shall be set out by the Bidders, clause by Clause in this schedule. Unless specifically mentioned in this Schedule, the tender shall be deemed to confirm the purchaser's specifications:

<b>SL. No</b>	<b>Clause No.</b>	<b>Details of deviation with justifications</b>

We confirm that there are no deviations apart from those detailed above.

Seal of the Company:

Signature

Designation

## **CONTENTS**

1. SCOPE
2. APPLICABLE STANDARDS
3. CLIMATIC CONDITIONS OF THE INSTALLATION
4. GENERAL TECHNICAL REQUIREMENTS
5. GENERAL CONSTRUCTIONS
6. MARKING
7. TESTS
8. TYPE TEST CERTIFICATES
9. PRE-DISPATCH INSPECTION
10. INSPECTION AFTER RECEIPT AT STORES
11. GUARANTEE
12. PACKING
13. TENDER SAMPLE
14. QUALITY CONTROL
15. TESTING FACILITIES
16. MANUFACTURING ACTIVITIES
17. SPARES, ACCESSORIES AND TOOLS
18. DRAWINGS AND DOCUMENTS
19. SCHEDULE "A" GUARANTEED TECHNICAL PARTICULARS
20. SCHEDULE "B" DEVIATIONS



**1. SCOPE**

The Specification covers the technical requirements of design, manufacture, test at manufacturer's works, packing & forwarding, supply and unloading at store/ site of 33 kV Pin polymer insulator 10 KN used in 33 kV Overhead Transmission lines.

**2. APPLICABLE STANDARDS**

The equipment covered by this specification shall unless otherwise stated, be designed, manufactured and tested in accordance with the latest editions of the following Indian, International Standards and shall conform to the regulations of the local authorities:

Ref. IS	Description
IEC: 61109	Definition, test methods and acceptance criteria for composite insulators for A.C. overhead lines above 1000V
IEC: 61952	Insulators for overhead lines – Composite line post insulators for alternative current systems with a nominal voltage greater than 1 000 V
IS: 2071/ IEC: 60060-1	Methods of High Voltage Testing
IS: 2486	Specification for Insulator fittings for Overhead power Lines with a nominal voltage greater than 1000V
IS: 13134/ IEC: 60815	Guide for the selection of insulators in respect of polluted condition
IS 8263/IEC: 60437	Methods of RI Test of HV insulators.
IS: 4759	Hot dip zinc coatings on structural steel & other allied products
IS: 2629	Recommended Practice for Hot, Dip Galvanization for iron and steel
IS: 2633	Testing of Uniformity of Coating of zinc coated articles
IS:6745	Method for determination of mass of zinc coating on zinc coated iron and steel articles
STRI Guide 1.92/1	Hydrophobicity Classification Guide
ASTM D 578-05	Standard specification for glass fiber strands

### 3. CLIMATIC CONDITIONS OF THE INSTALLATION:

SL.NO.	CONDITONS	VALUES
1	Max. altitude above sea level	1200m
2	Max. Ambient Temperature	50 °C
3	Max. Daily average ambient temp	35 °C
4	Min Ambient Temp	0 °C
5	Maximum temperature attainable by an object exposed to sun	60 °C
6	Maximum Humidity	95%
7	Minimum Humidity	10%
8	Average No. of thunderstorm days per annum	70
9	Average Annual Rainfall	150 cm
10	Average No. of rainy days per annum	120
11	Thermal Resistivity of soil	150 Deg. Ccm/W
12	Wind Pressure	126 kg/sq. m up to an elevation of 10 meter.
14	Earthquakes of intensity in horizontal direction	equivalent to seismic acceleration of 0.3g
15	Earthquakes of intensity in vertical direction	equivalent to seismic acceleration of 0.15g
16	Wind velocity	300 km/hr.

Environmentally, some of the regions, where the work will take place include coastal areas, subject to high relative humidity, which can give rise to condensation. Onshore winds will frequently be salt laden. On occasions, the combination of salt and condensation may create pollution conditions for outdoor insulators. Some places are in heavily industrial polluted areas. Therefore, Outdoor material and equipment shall be designed and protected for use in exposed, heavily polluted, salty, corrosive and humid coastal atmosphere.

The atmosphere is generally laden with mild acid and dust in suspension during the dry months and is subjected to fog in cold months. The design of equipment and accessories shall be suitable to withstand seismic forces corresponding to an acceleration of 0.1 g.

#### 4. GENERAL TECHNICAL REQUIREMENTS:

- i) The Composite insulators will be used on lines on which the conductor will be ACSR/AAAC of size up to 232 Sq.mm. The insulators should withstand the conductor tension, the reversible wind load as well as the high frequency vibrations due to wind.
- ii) Insulator shall be suitable for 3 Phase, 50 Hz effectively earthed 33kV Overhead Distribution System in a moderately/heavily polluted atmosphere.
- iii) **Bidder must be indigenous manufacturer and supplier of Composite insulator of rating 33kV** or above or must have developed proven in house technology and manufacturing process for composite insulators of above rating or possess technical collaboration/association with the manufacturer of composite insulators of rating 33kV or above. The Bidder shall furnish necessary evidence in support of the above along with the bid which can be in the form of certification from Utilities concerned, or any other documents to the satisfaction of the Owner.
- iv) Insulators shall have sheds with good self-cleaning properties. Insulator shed profile, spacing, projection etc. and selection in respect of polluted conditions shall be generally in accordance with the commendation of IEC- 60815/ IS: 13134.
- v) The tolerances on all dimensions e.g. diameter, length and creepage distance shall be allowed as follows in line with-IEC 61109:
  - $\pm (0.04d + 1.5)$  mm when  $d \leq 300$  mm
  - $\pm (0.025d+6)$  mm when  $d > 300$  mm

Where, d being the dimensions in millimetres for diameter, length or creepage distance as the case may be. **However, no negative tolerance shall be applicable to creepage distance.**
- vi) The composite insulators including the end fitting connection shall be standard design suitable for use with the hardware fittings of any make conforming to relevant IEC/IS standards.
- vii) All surfaces shall be clean, smooth, without cuts, abrasions or projections. No part shall be subjected to excessive localized pressure. The insulator and metal parts shall be so designed and manufactured that it shall avoid local corona formation and not generate any radio interference beyond specified limit under the operating conditions.

SL. NO.	TECHNICAL PARTICULARS	DESIRED VALUE
1	Type of insulator	33 kV Polymeric composite Pin Insulator
2	Reference Standard	IEC 61109
3	Material of FRP Rod	Boron free ECR
4	Material of sheds	High voltage grade

SL. NO.	TECHNICAL PARTICULARS	DESIRED VALUE
		Silicone rubber Wacker-Germany, Dow Corning-USA
5	Material of End Fittings	SGCI /MCI/ FORGED STEEL
6	Material of sealing compound	RTV Silicon
7	Colour of sheds	Grey
8	Rated system voltage	33 kV
9	Highest system voltage	36 kV
10	Dry Power Frequency Withstand voltage	95 kV
11	Wet Power Frequency Withstand voltage	75 kV
12	Dry Power Frequency Flashover Voltage	>95 kV
13	Wet Power Frequency Flashover Voltage	>75 kV
14	Dry Lightning Impulse withstand voltage	Positive: 170 KV Negative: 180 KV
15	Dry Lightning Impulse Flashover voltage	Positive: 210 KV Negative: 230 KV
16	RIV at 1 MHz when energized at 10 KV / 30 KV (rms) under dry condition	< 70 microvolt
17	Creepage distance (min)	900 mm
18	Min Failing load/ SCL (Specified cantilever Load)	10 KN
19	Dia of FRP Rod	32 mm
20	Length of FRP Rod (min)	300 mm
21	Dia of weather sheds	≥100 mm
22	Thickness of housing	3 mm
23	Dry arc distance(min)	300 mm
24	Method of fixing sheds to housing	Injection moulding
25	Visible Discharge Voltage	27 KV
26	Type of sheds	Aerodynamic
27	Dia of bottom end fitting	24 mm
28	Thread length of bottom end fitting	150 mm (min)

## 5. GENERAL CONSTRUCTIONS:

Polymeric Insulators shall consist of THREE parts, at least two of which are insulating parts:

- (a) Core- the internal insulating part
- (b) Housing- the external insulating part
- (c) Metal end fittings.

### 5.1 CORE

It shall be a glass-fiber reinforced epoxy resin rod of high strength (FRP rod). Glass fibers and resin shall be optimized in the FRP rod. Glass fibers shall be Boron free electrically corrosion resistant (ECR) glass fiber and shall exhibit both high electrical integrity and high

resistance to acid corrosion. The matrix of the FRP rod shall be Hydrolysis resistant. The FRP rod shall be manufactured through Pultrusion process. The FRP rod shall be void free. Electrically Corrosion Resistant (ECR) grade fiber glass reinforced plastic (FRP) rod having at least 80% fibres by weight.

## 5.2 POLYMER HOUSING:

The FRP rod shall be covered by a seamless sheath of high voltage grade Silicone rubber housing of thickness 3mm minimum. It shall be one- piece housing using only Injection Moulding process to cover the core. The housing shall be designed to provide the necessary creepage distance and protection against environmental influences, external pollution and humidity. Housing shall conform to the requirements of IEC 60815 with latest amendments. All surfaces shall be clean, smooth, without cuts, abrasions or projections. No part shall be subjected to excessive localized pressure. The insulator and metal parts shall be so designed and manufactured that it shall avoid local corona formation and not generate any radio interference beyond specified limit under the operating condition. It shall be extruded or directly moulded on core and shall have chemical bonding with the FRP rod. The strength of the bond shall be greater than the tearing strength of the polymer. Sheath material in the bulk as well as in the sealing / bonding area shall be free from voids.

## 5.3 WEATHERSHEDS

The composite polymer weathersheds made of high voltage grade Silicone rubber polymer shall be moulded as part of the sheath and shall be free from imperfections. It should protect the FRP rod against environmental influences, external pollution and humidity. The weathersheds should have **silicon content of minimum 40% by weight**. The strength of the weather shed to sheath interface shall be greater than the tearing strength of the polymer. The interface, if any, between sheds and sheath (housing) shall be free from voids. Housing and weathersheds material shall have tensile strength of 3 Mpa with 400% elongation minimum and tear strength of 16 N/mm.

## 5.4 HARDWARE FITTINGS:

End fitting transmit the mechanical load to the core. They shall be made of spheroidal graphite cast iron, malleable cast iron or forged steel or aluminium alloy. Metal end fitting shall be suitable for pin type hardware support of respective specified mechanical load and shall be hot dip galvanized in accordance with IS 2629. They shall be connected to the rod by means of a controlled compression technique. The outer of end fittings should be machined to make the surface uniform round to ensure effective sealing when housing is

moulded over it. The material used in fittings shall be corrosion resistant. As the main duty of the end fittings is the transfer of mechanical loads to the core the fittings should be properly attached to the core by a coaxial or hexagonal compression process & should not damage the individual fibers or crack the core. The gap between fittings and sheath shall be sealed by flexible silicone elastomeric compound or silicone alloy compound sealant, system of attached of end fitting to the rod shall provide superior sealing performance between housing, i.e. seamless sheath and metal connection. The sealing must be moisture proof. The dimensions of end fittings of insulators shall be in accordance with the standard dimensions stated in IS: 2486 - Part-II. Outer portion of Pin should be Zinc sleeved with minimum 99.95% purity of Electrolytic high grade zinc. Bottom end fitting should be single unit without any joints. Nuts as per IS 1363 (P-III) and spring washer shall be as per IS 3063 with Latest amendments if any, Nuts and spring washer shall be hot dip galvanized. The design of the insulator shall be such that stresses due to expansion and contraction in any part of the insulator shall not lead to deterioration. The pin insulator shall not engage directly with hard metal.

## 6. MARKING:

Each insulator shall be legibly and indelibly marked (embossing/engraved) to show the following:

- a) Name & Trade mark of the manufacturer
- b) Voltage Grade
- c) Year of manufacture
- d) Minimum failing load in KN
- e) "TPCODL/TPNODL/TPWODL/TPSODL" Name should be mentioned on each insulator

## 7. TESTS

The bidder shall be required to submit complete set of the following test reports along with the offer: -

### 7.1 ACCEPTANCE TESTS

- i) Verification of dimensions
- ii) End Sealing test (FRP rod and Silicone rubber housing)
- iii) Visual examination (Free from voids, cavity, foreign particle and scratch/nick spot)
- iv) Verification of the locking system or the tightness of the interface between end fitting and insulator housing
- v) Galvanizing Test

- vi) Verification of the specified mechanical load
- vii) Bending Load Test
- viii) Dry Power Frequency Withstand Voltage Test
- ix) Wet Power Frequency Withstand Voltage Test
- x) Analysis of material properties of housing material
- xi) Analysis of material properties of Core material

## 7.2 ROUTINE TESTS

- i) Visual examination (Free from voids, cavity, foreign particle and scratch/nick spot)
- ii) Mechanical Load test (Bending/Cantilever)

## 7.3 TYPE TESTS

### A) For Insulators

- i) Dry Power Frequency Withstand Voltage Test
- ii) Dry Power Frequency Voltage Flashover Test
- iii) Dry lightning impulse withstand voltage test.
- iv) Wet Power Frequency Withstand Voltage Test
- v) Wet Power Frequency Voltage Flashover Test
- vi) Mechanical failing load test.
- vii) Salt fog test: On insulators for 1000 hr as per IEC
- viii) Galvanization test
- ix) Radio interference test.

### B) For Silicon rubber

- i) Tensile Strength
- ii) Elongation
- iii) Tear Strength
- iv) Inclined plane Tracking & Erosion resistance test
- v) Volume Resistivity
- vi) Dielectric constant
- vii) Dielectric Strength
- viii) Density
- ix) Hardness
- x) Arc Resistance
- xi) Silicone Content
- xii) Flammability
- xiii) Limiting oxygen index test



- xiv) Resistance to weathering & UV.
- xv) Specific gravity

**C) For FRP rods**

- i) Verification of dimensions
- ii) Specific Gravity
- iii) Glass Content
- iv) Water Diffusion Test
- v) Hardness
- vi) Dye Penetration Test
- vii) Flexural Strength
- viii) Brittle fracture resistance test.

**8. TYPE TEST CERTIFICATES:**

The Bidder shall furnish the type test certificates of the for the tests as mentioned above as per the corresponding standards. All the tests shall be conducted at **CPRI/ERDA** as per the relevant IS/IEC. For **High voltage Silicone rubber material used for Polymer housing** the test are conducted at **CIPET/CPRI** as per the relevant standards. TPCODL/ TPWODL/ TPNODL/ TPSODL. TATA-POWER reserves the right to allow any other NABL accredited/ Govt. lab report under exceptional circumstances after due diligence/ scrutiny by DISCOM. Type tests should have been conducted in certified Test laboratories during the period not exceeding 5 years from the date of opening the bid. In the event of any discrepancy in the test reports, i.e. any test report not acceptable, same shall be carried out without any cost implication to TPCODL/TPNODL/TPWODL/TPSODL.

**9. PRE DISPATCH INSPECTION:**

The material shall be subject to inspection by a duly authorized representative of the TPCODL/TPNODL/TPWODL/TPSODL. Inspection may be made at any stage of manufacture at the discretion of the purchaser and the equipment, if found unsatisfactory as to workmanship or material, the same is liable to rejection. Bidder shall grant free access to the places of manufacture to TPCODL/TPNODL/TPWODL/TPSODL's representatives at all times when the work is in progress. Inspection by the TPCODL/TPNODL/TPWODL/TPSODL or its authorized representatives shall not relieve the bidder of his obligation of furnishing equipment in accordance with the specifications. Material shall be dispatched after specific MDCC (Material Dispatch Clearance Certificate) is issued by TPCODL/ TPNODL/ TPWODL/ TPSODL.



Following documents shall be sent along with material.

- a) Test reports
- b) MDCC issued by TPCODL/TPNODL/TPWODL/TPSODL
- c) Invoice in duplicate
- d) Packing list
- e) Drawings & catalogue
- f) Guarantee / Warrantee card
- g) Delivery Challan
- h) Other Documents (as applicable).

#### 10. INSPECTION AFTER RECEIPT AT STORES:

The material received at TPCODL/TPNODL/TPWODL/TPSODL, Odisha store will be inspected for acceptance and shall be liable for rejection, if found different from the reports of the pre-dispatch inspection and one copy of the report shall be sent to Engineering department.

#### 11. GUARANTEE:

Bidder shall stand guarantee towards design, materials, workmanship & quality of process/ manufacturing of items under the contract for due and intended performance of the same, as an integrated product delivered under this contract. In the event any defect is found by the Company up to a period of 18 months from the date of commissioning or 24 months from the date of last supplies made under the contract, whichever is earlier, supplier shall be liable to undertake to replace/rectify such defects at his own costs. within mutually agreed timeframe, and to the entire satisfaction of the Company, failing which the Company will be at liberty to get it replaced/rectified at supplier's risks and costs and recover all such expenses plus the Company's own charges (@ 20% of expenses incurred), from the supplier or from the "Security cum Performance Deposit" as the case may be.

The bidder shall further be responsible for 'free replacement' for another period of THREE years from the end of guarantee period for any 'latent defects' if noticed by the company.

#### 12. PACKING:

Supplier shall ensure that all the equipment covered under this specification shall be prepared for rail/road transport and be packed in such a manner so as to protect the equipment from damage in transit. The material used for packing shall be environmentally friendly. All insulators shall be packed in strong corrugated box of min. 7 ply duly palette or wooden crates. The gross weight of the crates along with the material shall not normally exceed 100 Kg to avoid handling problem. The crates shall be suitable for outdoor storage under wet

climate during rainy season. Each wooden case / crate / corrugated box shall have all the markings stencilled on it in indelible ink. The bidder shall provide instructions regarding handling and storage precautions to be taken at site.

**13. TENDER SAMPLE:**

Bidder shall submit the sample of material during submission of Bids.

**14. QUALITY CONTROL:**

The bidder shall submit with the offer Quality Assurance Plan indicating the various stages of inspection, the tests and checks which will be carried out on the material of construction, components during manufacture and bought out items and fully assembled component and equipment after finishing. As part of the plan, a schedule for stage and final inspection within the parameters of the delivery schedule shall be furnished. The Purchaser's engineer or its nominated representative shall have free access to the manufacturer's/sub-supplier's works to carry out inspections. The bidder shall ensure that the material supplied is as per the Guaranteed Technical Particulars as specified in the specifications.

**15. TESTING FACILITIES:**

Bidder shall have adequate in-house testing facilities for carrying out all routine tests & acceptance tests as per relevant International / Indian standards.

**16. MANUFACTURING ACTIVITIES:**

The successful bidder will have to submit the bar chart for various manufacturing activities clearly elaborating each stage, with quantity. This bar chart should be in line with the Quality assurance plan submitted with the offer.

**17. SPARES, ACCESSORIES AND TOOLS**

Not applicable.

**18. DRAWINGS AND DOCUMENTS**

Following drawings and documents shall be submitted in line with the requirement of Tender specifications:

- a) Completely filled in Schedule "A" Guaranteed Technical Particulars & Schedule "B" Deviations
- b) Work Experience details
- c) Type test certificates.
- d) Drawing 1 set of Hard Copy & Soft copy PDF File containing complete information about

manufacturing.

**19. SCHEDULE- "A" GUARANTEED TECHNICAL PARTICULARS**

SL. NO.	TECHNICAL PARTICULARS	TO BE FURNISHED BY BIDDER
1	Type of insulator	
2	Reference Standard	
3	Material of FRP Rod	
4	Material of sheds	
5	Material of End Fittings	
6	Material of sealing compound	
7	Color of sheds	
8	Rated system voltage	
9	Highest system voltage	
10	Dry Power Frequency Withstand voltage	
11	Wet Power Frequency Withstand voltage	
12	Dry Lightning Impulse withstand voltage	
13	Dry Lightning Impulse Flashover voltage	
14	RIV at 1 MHz when energized at 10 KV / 30 KV (rms) under dry condition	
15	Creepage distance (min)	
16	Min Failing load/ SCL (Specified cantilever Load)	
17	Dia of FRP Rod	
18	Length of FRP Rod (min)	
19	Dia of weather sheds	
20	Thickness of housing	
21	Dry arc distance(min)	
22	Method of fixing sheds to housing	
23	Visible Discharge Voltage	
24	Type of sheds	
25	Dia of bottom end fitting	
26	Thread length of bottom end fitting	

**20. SCHEDULE “B” DEVIATIONS:**

**(TO BE ENCLOSED WITH TECHNICAL BID)**

All deviations from this specification shall be set out by the Bidders, clause by clause in this schedule. Unless specifically mentioned in this Schedule, the tender shall be deemed to confirm the purchaser's specifications:

SL. No	Clause No.	Details of deviation with justifications

We confirm that there are no deviations apart from those detailed above.

Seal of the Company:

Signature

Designation

## **CONTENTS**

1. SCOPE
2. APPLICABLE STANDARDS
3. CLIMATIC CONDITIONS OF THE INSTALLATION
4. GENERAL TECHNICAL REQUIREMENTS
5. GENERAL CONSTRUCTIONS
6. MARKING
7. TESTS
8. TYPE TEST CERTIFICATES
9. PRE-DISPATCH INSPECTION
10. INSPECTION AFTER RECEIPT AT STORES
11. GUARANTEE
12. PACKING
13. TENDER SAMPLE
14. QUALITY CONTROL
15. TESTING FACILITIES
16. MANUFACTURING ACTIVITIES
17. SPARES, ACCESSORIES AND TOOLS
18. DRAWINGS AND DOCUMENTS
19. SCHEDULE "A" GUARANTEED TECHNICAL PARTICULARS
20. SCHEDULE "B" DEVIATIONS

## 1. SCOPE

This specification covers the technical requirements of design, manufacture, performance, testing at manufacturer's works, packing & forwarding, supply and unloading at store/ site, performance of 33 kV Ball and Socket Disc Polymer Insulator complete with all the accessories for trouble free and efficient performance.

## 2. APPLICABLE STANDARDS

The equipment covered by this specification shall unless otherwise stated, be designed, manufactured and tested in accordance with the latest editions of the following Indian, International Standards and shall conform to the regulations of the local authorities:

Ref. IS/IEC	Description
IEC:61109	Definition, test methods and acceptance criteria for composite insulators for A.C. overhead lines above 1000V.
IS:2071/ IEC:60060-1	Methods of High Voltage Testing.
IS:2486/ IEC:60120/ IEC:60372	Specification for Insulator fittings for Overhead Power Lines with a nominal voltage greater than 1000V.  Ball and socket couplings of string insulator units –Dimensions  Locking devices for ball and socket couplings of string insulator units - Dimensions and tests
IEC:60575	Thermal-mechanical performance test and mechanical performance test on string insulator units.
IS: 13134/ IEC: 60815	Guide for the selection of insulators in respect of polluted condition.
IEC: 60433	Insulators for overhead lines with a nominal voltage above 1000 V - Ceramic insulators for AC systems - Characteristics of insulator units of the long rod type.
STRI guide 1.92/1	Hydrophobicity Classification Guide.
IS:8263/ IEC:60437	Methods of RI Test of HV Insulators.
IS:4759	Hot dip zinc coatings on structural steel & other allied products.
IS:2629	Recommended practice for Hot Dip galvanization for iron and steel
IS:6745	Method for determination of mass of zinc coating on zinc coated iron and steel articles.
IS:3203	Methods of testing of local thickness of electroplated coatings.

Ref. IS/IEC	Description
IS:2633	Testing of Uniformity of coating of zinc coated articles.
ASTM D 578-05	Standard specification for glass fiber standards.
IS:4699	Refined secondary zinc

### 3. CLIMATIC CONDITIONS OF THE INSTALLATION:

SL.NO.	CONDITONS	VALUES
1	Max. altitude above sea level	1200m
2	Max. Ambient Temperature	50 °C
3	Max. Daily average ambient temp	35 °C
4	Min Ambient Temp	0 °C
5	Maximum temperature attainable by an object exposed to sun	60 °C
6	Maximum Humidity	95%
7	Minimum Humidity	10%
8	Average No. of thunderstorm days per annum	70
9	Average Annual Rainfall	150 cm
10	Average No. of rainy days per annum	120
11	Thermal Resistivity of soil	150 Deg. Ccm/W
12	Wind Pressure	126 kg/sq. m up to an elevation of 10 meter.
14	Earthquakes of intensity in horizontal direction	equivalent to seismic acceleration of 0.3g
15	Earthquakes of intensity in vertical direction	equivalent to seismic acceleration of 0.15g
16	Wind velocity	300 km/hr.

Environmentally, some of the regions, where the work will take place include coastal areas, subject to high relative humidity, which can give rise to condensation. Onshore winds will frequently be salt laden. On occasions, the combination of salt and condensation may create pollution conditions for outdoor insulators. Some places are in heavily industrial polluted areas. Therefore, Outdoor material and equipment shall be designed and protected for use in exposed, heavily polluted, salty, corrosive and humid coastal atmosphere.

The atmosphere is generally laden with mild acid and dust in suspension during the dry months and is subjected to fog in cold months. The design of equipment and accessories shall be suitable to withstand seismic forces corresponding to an acceleration of 0.1 g.

#### 4. GENERAL TECHNICAL REQUIREMENTS:

- i) The Composite insulators will be used on 33kV lines on which the conductor will be ACSR/AAAC of sizes 148 & 232 Sq.mm. The insulators should withstand the conductor tension, the reversible wind load as well as the high frequency vibrations due to wind. Insulator shall be suitable for moderately to heavily polluted, Humid & High saline atmosphere.
- ii) Bidder must be indigenous manufacturer and supplier of Composite insulator of rating 33kV or above or must have developed proven in house technology and manufacturing process for composite insulators of above rating or possess technical collaboration/association with the manufacturer of composite insulators of rating 33kV or above. The Bidder shall furnish necessary evidence in support of the above along with the bid which can be in the form of certification from Utilities concerned, or any other documents to the satisfaction of the Owner.
- iii) Insulators shall be suitable for Strain type of load and shall be of B&S type. The diameter of Composite Insulator shall be as per technical specification.
- iv) Insulators shall have sheds with good self-cleaning properties. Insulator shed profile, spacing, projection etc. and selection in respect of polluted conditions shall be generally in accordance with the commendation of IEC- 60815/ IS: 13134.
- v) The tolerances on all dimensions e.g. diameter, length and creepage distance shall be allowed as follows in line with-IEC 61109:
  - ± (0.04d + 1.5) mm when d ≤ 300 mm
  - ± (0.025d+6) mm when d > 300 mm

Where, d being the dimensions in millimetres for diameter, length or creepage distance as the case may be. **However, no negative tolerance shall be applicable to creepage distance.**

- vi) The composite insulators including the end fitting connection shall be standard design



suitable for use with the hardware fittings of any make conforming to relevant IEC/IS standards.

- vii) All surfaces shall be clean, smooth, without cuts, abrasions or projections. No part shall be subjected to excessive localized pressure. The insulator and metal parts shall be so designed and manufactured that it shall avoid local corona formation and not generate any radio interference beyond specified limit under the operating conditions.
- viii) The composite insulators offered shall be suitable for use of hotline maintenance technique so that usual hot line operation can be carried out with ease, speed and safety.

SL. No.	TECHNICAL PARTICULARS	DESIRED VALUE	
		33 kV 90 KN	33 kV 120 KN
1	Type of Insulator	Polymeric B&S	Polymeric B&S
2	Standard according to which the insulators manufactured and tested.	IEC 61109	IEC 61109
3	Name of material used in manufacture of the insulator with class/grade)	High voltage grade Silicone rubber Wacker-Germany, Dow Corning-USA	High voltage grade Silicone rubber Wacker-Germany, Dow Corning-USA
(a)	Material of core (FRP rod) (I) E-glass of ECR-glass.	ECR or BORRON FREE	ECR or BORRON FREE
(b)	Material of housing weather sheds (silicon content)	Silicon content of minimum 40% by weight	Silicon content of minimum 40% by weight
(c)	Material of end fittings	SGI/Forged Steel	SGI/Forged Steel
(d)	Sealing compound for end fittings	RTV SILICON	RTV SILICON
4	Colour	GREY	GREY
5	Electrical characteristics		
(a)	Nominal system voltage	33 kV	33 kV
(b)	Highest system voltage	36 kV	36 kV
(c)	Dry Power frequency withstand voltage	105 kV	105 kV
(d)	Wet Power frequency withstand voltage	75 kV	75 kV
(e)	Dry flashover voltage	>105 kV	>105 kV
(f)	Wet flash over voltage	>75kV	>75kV
(g)	Dry lighting impulse withstand voltage		
	(a) Positive	170 kVp	170 kVp
	(b) Negative	180 kVp	180 kVp
(h)	Dry lighting impulse flashover voltage		
	a) Positive	180kVp	180kVp
	b) Negative.	190kVp	190kVp
(i)	FRP rod leakage current at 175 V/mm	< 0.05 mA	< 0.05 mA
(j)	RIV at 1 MHz when energized at 10 kV/30kV (rms) under dry condition.	< 50 microvolt	< 50 microvolt

SL. No.	TECHNICAL PARTICULARS	DESIRED VALUE	
		33 kV 90 KN	33 kV 120 KN
(k)	Creepage distance (Min.)	900 MM	900 MM
6	Minimum failing load.	90 KN	120 KN
7	<b>Dimensions of insulator</b>		
(i)	Weight	1.6 kg	1.8 kg
(ii)	Dia of FRP rod	16 mm	20 mm
(iii)	Length of FRP rod	440 mm	440 mm
(iv)	Dia of weather sheds	≥100 mm	≥100 mm
(v)	Thickness of housing	3 mm	3 mm
(vi)	Dry arc distance Dimensioned drawings of insulator (including weight with tolerances in weight)	380 mm	380 mm
8	Method of fixing of sheds to housing (specify). Single mould or Modular construction (injection moulding/compression)	Injection Moulding	Injection Moulding
9	Type of sheds	Aerodynamic	Aerodynamic

## 5. GENERAL CONSTRUCTIONS:

Composite Insulators shall be designed to meet the light quality, safety and reliability and are capable of withstanding a wide range of environmental conditions. Polymeric Insulators shall consist of THREE parts, at least two of which are insulating parts:

- (a) Core- the internal insulating part
- (b) Housing- the external insulating part
- (c) Metal end fittings.

### 5.1 CORE

It shall be a glass-fiber reinforced epoxy resin rod of high strength (FRP rod). Glass fibers and resin shall be optimized in the FRP rod. Glass fibers shall be Boron free electrically corrosion resistant (ECR) glass fiber and shall exhibit both high electrical integrity and high resistance to acid corrosion. The matrix of the FRP rod shall be Hydrolysis resistant. The FRP rod shall be manufactured through Pultrusion process. The FRP rod shall be void free. Electrically Corrosion Resistant (ECR) grade fiber glass reinforced plastic (FRP) rod having at least 80% fibres by weight.

### 5.2 POLYMER HOUSING:

The FRP rod shall be covered by a seamless sheath of high voltage grade Silicone rubber housing of thickness 3mm minimum. It shall be one- piece housing using only Injection Moulding process to cover the core. The housing shall be designed to provide the necessary creepage distance and protection against environmental influences, external

pollution and humidity. Housing shall conform to the requirements of IEC 60815 with latest amendments. All surfaces shall be clean, smooth, without cuts, abrasions or projections. No part shall be subjected to excessive localized pressure. The insulator and metal parts shall be so designed and manufactured that it shall avoid local corona formation and not generate any radio interference beyond specified limit under the operating condition. It shall be extruded or directly moulded on core and shall have chemical bonding with the FRP rod. The strength of the bond shall be greater than the tearing strength of the polymer. Sheath material in the bulk as well as in the sealing / bonding area shall be free from voids.

### 5.3 WEATHERSHEDS

The composite polymer weathersheds made of high voltage grade Silicone rubber polymer shall be moulded as part of the sheath and shall be free from imperfections. It should protect the FRP rod against environmental influences, external pollution and humidity. The weathersheds should have **silicon content of minimum 40% by weight**. The strength of the weather shed to sheath interface shall be greater than the tearing strength of the polymer. The interface, if any, between sheds and sheath (housing) shall be free from voids. Housing and weathersheds material shall have tensile strength of 3 Mpa with 400% elongation minimum and tear strength of 16 N/mm.

### 5.4 HARDWARE FITTINGS:

- a) End fitting transmit the mechanical load to the core. They shall be made of spheroidal graphite cast iron, malleable cast iron or forged steel or aluminium alloy. Metal end fitting shall be suitable for Ball and socket type hardware of respective specified mechanical load and shall be hot dip galvanized in accordance with IS 2629.
- b) They shall be connected to the rod by means of a controlled compression technique. The material used in fittings shall be corrosion resistant. As the main duty of the end fittings is the transfer of mechanical loads to the core the fittings should be properly attached to the core by a coaxial or hexagonal compression process & should not damage the individual fibers or crack the core.
- c) The gap between fittings and sheath shall be sealed by flexible silicone elastomeric compound or silicone alloy compound sealant, system of attached of end fitting to the rod shall provide superior sealing performance between housing, i.e. seamless sheath and metal connection. The sealing must be moisture proof.
- d) The dimensions of end fittings of insulators shall be in accordance with the standard dimensions stated in IEC: 60120/IS: 2486 - Part-II.
- e) Outer portion of ball or socket should be Zinc sleeved with minimum 99.95% purity of Electrolytic high grade zinc.

- f) **Ball pin and socket couplings:** Ball pin and socket shall be of forged steel and dimensions are as specified in IS 2486 (Part-2). Insulator metal caps shall be made of malleable cast iron conforming to IS 14329.
- g) **Locking device of the coupling:** The security clips to be used as a locking device for ball and socket coupling shall be 'R' shaped hump type or 'W' type as per IS 2486. The locking device shall be resilient, corrosion resistant, and of suitable mechanical strength. Material to be used for 'W' locking clip is phosphor bronze and for 'R' type locking clip is stainless steel. The hardness and temper of material are important for their satisfactory operation. The locking devices shall retain their ability after being operated from the locking to the coupling position at least twenty times at normal temperature. They should be effective at the lowest temperature likely to be encountered in service. Socket for use with W-clips have the lower edge of the rectangular slot at the level of bottom of the socket. The slot is so shaped that it will accept the W-clip and retain it in two distinct positions when operated for coupling and locking. The shape of the W-clip is such that complete withdrawal when moving from the locking to the coupling position prevented.
- h) All ferrous parts shall be hot dip galvanized to give a minimum average coating of zinc equivalent to 705 gm/Sq.m, or 100mm min. thickness and shall be in accordance with the requirement of IS: 4759, The zinc used for galvanizing shall be of purity 99.5% as per IS: 4699. The zinc coating shall be uniform, adherent, smooth, reasonably bright continuous and free from imperfections such as flux, ash rust stains, bulky white deposits and blisters. Before ball fittings and galvanized, all die flashing on the shank and on the bearing surface of the ball shall be carefully removed without reducing the design dimensional requirements.

## 6. MARKING:

Each insulator shall be legibly and indelibly marked (embossing/engraved) to show the following:

- Name & Trade mark of the manufacturer
- Voltage Grade
- Year of manufacturing
- Minimum failing load in KN
- "TPCODL/TPNODL/TPWODL/TPSODL" Name should be mentioned on each insulator

## 7. TESTS

The bidder shall be required to submit complete set of the following test reports along with the offer: -

## 7.1 ACCEPTANCE TESTS

- i) Verification of dimensions
- ii) End Sealing test (FRP rod and Silicone rubber housing)
- iii) Visual examination (Free from voids, cavity, foreign particle and scratch/nick spot)
- iv) Mechanical performance Test
- v) Galvanizing Test
- vi) Mechanical Failing Load Test
- vii) Dry Power Frequency Withstand Voltage Test
- viii) Wet Power Frequency Withstand Voltage Test

## 7.2 ROUTINE TESTS

- i) Visual examination (Free from voids, cavity, foreign particle and scratch/nick spot)
- ii) Mechanical Load test
- iii) Electrical Routine Test

## 7.3 TYPE TESTS

### A) For Insulators

- i) Dry Power Frequency Withstand Voltage Test
- ii) Dry Power Frequency Voltage Flashover Test
- iii) Dry lightning impulse withstand voltage test.
- iv) Wet Power Frequency Withstand Voltage Test
- v) Wet Power Frequency Voltage Flashover Test
- vi) Mechanical failing load test.
- vii) Salt fog test: On insulators for 1000 hr as per IEC
- viii) Galvanization test
- ix) Damaged Limit Proof Test
- x) Radio interference test.

### B) For Silicon rubber

- i) Tensile Strength
- ii) Elongation
- iii) Tear Strength
- iv) Inclined plane Tracking & Erosion resistance test
- v) Volume Resistivity
- vi) Dielectric constant
- vii) Dielectric Strength
- viii) Density
- ix) Hardness

- x) Arc Resistance
- xi) Silicone Content
- xii) Flammability
- xiii) Limiting oxygen index test
- xiv) Resistance to weathering & UV.
- xv) Specific gravity

**C) For FRP rods**

- i) Verification of dimensions
- ii) Specific Gravity
- iii) Glass Content
- iv) Water Diffusion Test
- v) Hardness
- vi) Dye Penetration Test
- vii) Flexural Strength
- viii) Brittle fracture resistance test.
- ix) Water Diffusion Test

**D) For End Fittings**

- i) Thickness of Zinc coating
- ii) Uniformity of Zinc Coating
- iii) Micro-structural of metal fitting

**8. TYPE TEST CERTIFICATES:**

The Bidder shall furnish the type test certificates of the for the tests as mentioned above as per the corresponding standards. All the tests shall be conducted at **CPRI/ERDA** as per the relevant IS/IEC. For **High voltage Silicone rubber material used for Polymer housing** the test are conducted at **CIPET/CPRI** as per the relevant standards. TPCODL/ TPWODL/ TPNODL/ TPSODL. TATA-POWER reserves the right to allow any other NABL accredited/ Govt. lab report under exceptional circumstances after due diligence/ scrutiny by DISCOM. Type tests should have been conducted in certified Test laboratories during the period not exceeding 5 years from the date of opening the bid. In the event of any discrepancy in the test reports, i.e. any test report not acceptable, same shall be carried out without any cost implication to TPCODL/TPNODL/TPWODL/TPSODL.

**9. PRE DISPATCH INSPECTION:**

The material shall be subject to inspection by a duly authorized representative of the TPCODL/TPNODL/TPWODL/TPSODL. Inspection may be made at any stage of

manufacture at the discretion of the purchaser and the equipment, if found unsatisfactory as to workmanship or material, the same is liable to rejection. Bidder shall grant free access to the places of manufacture to TPCODL/TPNODL/TPWODL/TPSODL's representatives at all times when the work is in progress. Inspection by the TPCODL/TPNODL/TPWODL/TPSODL or its authorized representatives shall not relieve the bidder of his obligation of furnishing equipment in accordance with the specifications. Material shall be dispatched after specific MDCC (Material Dispatch Clearance Certificate) is issued by TPCODL/TPNODL/TPWODL/TPSODL.

Following documents shall be sent along with material.

- a) Test reports
- b) MDCC issued by TPCODL/TPNODL/TPWODL/TPSODL
- c) Invoice in duplicate
- d) Packing list
- e) Drawings & catalogue
- f) Guarantee / Warrantee card
- g) Delivery Challan
- h) Other Documents (as applicable).

#### **10. INSPECTION AFTER RECEIPT AT STORES:**

The material received at TPCODL/TPNODL/TPWODL/TPSODL, Odisha store will be inspected for acceptance and shall be liable for rejection, if found different from the reports of the pre-dispatch inspection and one copy of the report shall be sent to Engineering department.

#### **11. GUARANTEE:**

Bidder shall stand guarantee towards design, materials, workmanship & quality of process/manufacturing of items under the contract for due and intended performance of the same, as an integrated product delivered under this contract. In the event any defect is found by the Company up to a period of 18 months from the date of commissioning or 24 months from the date of last supplies made under the contract, whichever is earlier, supplier shall be liable to undertake to replace/rectify such defects at his own costs. within mutually agreed timeframe, and to the entire satisfaction of the Company, failing which the Company will be at liberty to get it replaced/rectified at supplier's risks and costs and recover all such expenses plus the Company's own charges (@ 20% of expenses incurred), from the supplier or from the "Security cum Performance Deposit" as the case may be.

The bidder shall further be responsible for 'free replacement' for another period of THREE years from the end of guarantee period for any 'latent defects' if noticed by the company.



**12. PACKING:**

Supplier shall ensure that all the equipment covered under this specification shall be prepared for rail/road transport and be packed in such a manner so as to protect the equipment from damage in transit. The material used for packing shall be environmentally friendly. All insulators shall be packed in strong corrugated box of min. 7 ply duly palette or wooden crates. The gross weight of the crates along with the material shall not normally exceed 100 Kg to avoid handling problem. The crates shall be suitable for outdoor storage under wet climate during rainy season. Each wooden case / crate / corrugated box shall have all the markings stencilled on it in indelible ink. The bidder shall provide instructions regarding handling and storage precautions to be taken at site.

**13. TENDER SAMPLE:**

Bidder shall submit the sample of material during submission of Bids.

**14. QUALITY CONTROL:**

The bidder shall submit with the offer Quality Assurance Plan indicating the various stages of inspection, the tests and checks which will be carried out on the material of construction, components during manufacture and bought out items and fully assembled component and equipment after finishing. As part of the plan, a schedule for stage and final inspection within the parameters of the delivery schedule shall be furnished. The Purchaser's engineer or its nominated representative shall have free access to the manufacturer's/sub-supplier's works to carry out inspections. The bidder shall ensure that the material supplied is as per the Guaranteed Technical Particulars as specified in the specifications.

**15. TESTING FACILITIES:**

Bidder shall have adequate in-house testing facilities for carrying out all routine tests & acceptance tests as per relevant International / Indian standards.

**16. MANUFACTURING ACTIVITIES:**

The successful bidder will have to submit the bar chart for various manufacturing activities clearly elaborating each stage, with quantity. This bar chart should be in line with the Quality assurance plan submitted with the offer.

**17. SPARES, ACCESSORIES AND TOOLS**

Not applicable.

**18. DRAWINGS AND DOCUMENTS**

Following drawings and documents shall be submitted in line with the requirement of Tender specifications:



- a) Completely filled in Schedule “A” Guaranteed Technical Particulars & Schedule “B” Deviations
- b) Work Experience details
- c) Type test certificates.
- d) Drawing 1 set of Hard Copy & Soft copy PDF File containing complete information about manufacturing.

**19. SCHEDULE- “A” GUARANTEED TECHNICAL PARTICULARS**

SL. No.	TECHNICAL PARTICULARS	To Be Furnished By The Bidder	
		33 kV 90 KN	33 kV 120 KN
1	Type of Insulator		
2	Standard according to which the insulators manufactured and tested.		
3	Name of material used in manufacture of the insulator with class/grade)		
(a)	Material of core (FRP rod) (I) E-glass of ECR-glass.		
(b)	Material of housing weather sheds (silicon content)		
(c)	Material of end fittings		
(d)	Sealing compound for end fittings		
4	Colour		
5	Electrical characteristics		
(a)	Nominal system voltage		
(b)	Highest system voltage		
(c)	Dry Power frequency withstand voltage		
(d)	Wet Power frequency withstand voltage		
(e)	Dry flashover voltage		
(f)	Wet flash over voltage		
(g)	Dry lighting impulse withstand voltage		
	(a) Positive		
	(b) Negative		
(h)	Dry lighting impulse flashover voltage		
	a) Positive		
	b) Negative.		
(i)	FRP rod leakage current at 175 V/mm		

SL. No.	TECHNICAL PARTICULARS	To Be Furnished By The Bidder	
		33 kV 90 KN	33 kV 120 KN
(j)	RIV at 1 MHz when energized at 10 kV/30kV (rms) under dry condition.		
(k)	Creepage distance (Min.)		
6	Minimum failing load.		
7	<b>Dimensions of insulator</b>		
(i)	Weight (Approx.)		
(ii)	Dia of FRP rod		
(iii)	Length of FRP rod		
(iv)	Dia of weather sheds		
(v)	Thickness of housing		
(vi)	Dry arc distance Dimensioned drawings of insulator (including weight with tolerances in weight)		
8	Method of fixing of sheds to housing (specify). Single mould or Modular construction (injection moulding/compression		
9	Type of sheds		

**20. SCHEDULE “B” DEVIATIONS:**

**(TO BE ENCLOSED WITH TECHNICAL BID)**

All deviations from this specification shall be set out by the Bidders, clause by Clause in this schedule. Unless specifically mentioned in this Schedule, the tender shall be deemed to confirm the purchaser's specifications:

SL. No	Clause No.	Details of deviation with justifications

We confirm that there are no deviations apart from those detailed above.

Seal of the Company:

Signature

Designation

# **STANDARD TECHNICAL SPECIFICATION COVER SHEET**

**Specification No. : ENG-GEN-4004**

**Specification Name : AAAC CONDUCTOR- 100,148, 232 Sq.mm**

<b>JYOTIPRAKASH MOHANTY</b>	<b>SATYA PRASAD NAYAK</b>	<b>Vijender Goyal</b>	<b>SHANTAPRIYA JENA</b>	<b>ANUP JAWASE</b>	<b>VARUN BHATNAGAR</b>
Prepared by	Reviewed by	Reviewed by	Reviewed by	Approved by	Released by
TPWODL	TPCODL	TPSODL	TPNODL	TPWODL	TPWODL
02-01-2023	03-01-2023	03-01-2023	03-01-2023	03-01-2023	04-01-2023

*Property of TATA POWER ODISHA DISCOMs – Not to be reproduced without permission of TPCODL/ TPNODL/ TPSODL/  
TPWODL*



**Specification No:** [ENG-GEN-4004](#)

**Specification Name:**  
SPECIFICATION FOR AAAC CONDUCTOR- 100,148,  
232 Sq.mm

## **CONTENTS**

1. SCOPE
2. APPLICABLE STANDARDS
3. CLIMATIC CONDITIONS OF THE INSTALLATION
4. GENERAL TECHNICAL REQUIREMENTS
5. GENERAL CONSTRUCTIONS
6. MARKING
7. TESTS
8. TYPE TEST CERTIFICATES
9. PRE-DISPATCH INSPECTION
10. INSPECTION AFTER RECEIPT AT STORES
11. GUARANTEE
12. PACKING
13. TENDER SAMPLE
14. QUALITY CONTROL
15. TESTING FACILITIES
16. MANUFACTURING FACILITIES
17. SPARES, ACCESSORIES AND TOOLS
18. DRAWINGS AND DOCUMENTS
19. SCHEDULE "A" GUARANTEED TECHNICAL PARTICULARS
20. SCHEDULE "B" DEVIATIONS



**Specification No:** [ENG-GEN-4004](#)

**Specification Name:**  
SPECIFICATION FOR AAAC CONDUCTOR- 100,148,  
232 Sq.mm

### 1. SCOPE:

This specification covers the technical requirements of design, manufacture, testing at manufacturer's works, packing, forwarding, supply and unloading at site/store and performance of AAAC Conductors(100 Sq.mm,148 Sq.mm,232 Sq.mm) with all accessories and necessary training for trouble free & efficient performance.

### 2. APPLICABLE STANDARDS:

AAAC Conductors covered by this specification shall unless otherwise stated, be designed, manufactured and tested in accordance with latest revisions of relevant Indian Standards/ IEC and shall conform to the regulations of local statutory authorities.

SI. No	IEC/IS	Description
1	IEC :1089	Round wire concentric lay overhead electrical standard Conductor
2	IS 398:4	Aluminum Alloy Stranded Conductors
3	IS 9997	Aluminum Alloy redraw rods for electrical purposes
4	IEC 502: 1994	Extruded solid dielectric insulated power cables for rated voltages 1.0 kV up to 30 kV
5	IEC 104	Aluminum Magnesium Silicon alloy wire for overhead line conductors
6	IS 1778	Reels and drums of bare conductor.

### 3. CLIMATIC CONDITIONS:

1	Maximum ambient temperature	50 deg C
2	Max. Daily average ambient temp	35 deg C
3	Min Ambient Temperature	0 deg C
4	Maximum Humidity	95%



Specification No: [ENG-GEN-4004](#)

Specification Name:  
SPECIFICATION FOR AAAC CONDUCTOR- 100,148,  
232 Sq.mm

5	Average Annual Rainfall	150cm
6	Average No. of rainy days per annum	120
7	Altitude above MSL not exceeding	1200m
8	Wind Pressure	300 Km/hr.
9	Earthquakes of an intensity in horizontal direction	equivalent to seismic acceleration of 0.3g
10	Earthquakes of an intensity in vertical direction	equivalent to seismic acceleration of 0.15g (g being acceleration due to gravity)

TPCODL/TPNODL/TPSODL/TPWODL service area has heavy saline conditions along the coast and High cyclonic Intensity winds with speed up to 300 Kmph. The atmosphere is generally laden with mild acid, dust in suspension during the dry months, and is subjected to fog in cold months.

#### 4. GENERAL TECHNICAL REQUIREMENTS:

The wires shall be of heat-treated aluminum, magnesium silicon alloy containing approximately silicon-0.5 to 0.9 %, magnesium-0.6 % to 0.9%, Fe-0.5% (maximum), Copper- 0.1% (max), Mn-0.03%, Cr-0.03%, Zn-0.1%, B-0.06%, and having the mechanical and electrical properties specified in the table and be smooth and free from all imperfections, such as, spills, splits and scratches. Neutral grease shall be applied between the layers of wires. The drop point temperature of the grease shall not be less than 120°C.

SL. NO.	TECHNICAL PARTICULARS	UNIT	DOG (100Sq.mm) (7 / 4.26mm)	COYOTE (148 Sq.mm) (19 / 3.15mm)	PANTHER (232 Sq.mm) (19 / 3.94mm)
1	Make				
a)	Aluminium Alloy rod		HINDALCO/BALCO/ VEDANTA/ NALCO		
b)	Conductor		Name of Company		
2	Type	No/mm	7 / 4.26	19 / 3.15	19 / 3.94
3	Particulars of Raw material				
a)	Si	%	0.50 - 0.90	0.50 - 0.90	0.50 - 0.90
b)	Mg	%	0.60-0.90	0.60-0.90	0.60-0.90
c)	FE	%	0.50 max	0.50 max	0.50 max
d)	Cu	%	0.10 max	0.10 max	0.10 max
e)	Mn	%	0.03 max	0.03 max	0.03 max



Specification No: [ENG-GEN-4004](#)

Specification Name:  
SPECIFICATION FOR AAAC CONDUCTOR- 100,148,  
232 Sq.mm

f)	Cr.	%	0.03 max	0.03 max	0.03 max
g)	Zn	%	0.10 max	0.10 max	0.10 max
h)	B	%	0.06 max	0.06 max	0.06 max
i)	Other Elements (Each)	%	0.03 max	0.03 max	0.03 max
j)	Other Elements (Total)	%	0.10 max	0.10 max	0.10 max
k)	Aluminium	%	Remainder	Remainder	Remainder
4	Aluminium Alloy wire Strands				
i	Diameter (mm)				
a)	Normal	mm	4.26	3.15	3.94
b)	Maximum	mm	4.3	3.18	3.98
c)	Minimum	mm	4.22	3.12	3.90
ii	Cross Section Area of Nominal dia. wire	Sq. mm	14.25	7.79	12.19
iii	Minimum Breaking Load of each strand after stranding	KN	4.18	2.29	3.58
iv	Minimum elongation % on gauge length of 200 mm (After Strand)	%	4	4	4
v	Max. Resistance at 20 Deg.C	Ohm/ KM	2.345	4.290	2.746
5	AAAC Stranded conductor		DOG	COYOTE	PANTHER
5.1	Nominal Sectional Area	sq. m	100	148	232
5.2	Overall Diameter	mm	12.78	15.75	19.70
5.3	Approx. Mass	Kg. /Km	272.86	406.91	636.67
5.4	Minimum Ultimate Breaking Load of Conductor	KN	29.26	43.5	68.05
5.5	Lay ratio of conductor (Min. / Max.)		10 / 14	10/16	10/16
5.6	Calculated Max. resistance of conductor at 20° C	Ohm/ Km.	0.3390	0.2290	0.1471
6	Standard length of conductor (meter)	Mtr.	2000	2000	2000
6.1	Continuous max. current carrying capacity in still air at 40°C ambient temperature	Amp	345(min)	447(min)	593(min)





Specification No: [ENG-GEN-4004](#)

Specification Name:  
SPECIFICATION FOR AAAC CONDUCTOR- 100,148,  
232 Sq.mm

6.2	Temperature rises for above current		35° C Over the ambient	35° C Over the ambient	35° C Over the ambient
6.3	Tolerance on standard length of Conductor (%)	%	±5		
6.4	Direction of lay for outside layer		Right Hand		
7	Modulus of Elasticity	Kg/cm <sup>2</sup>	0.6324 x10 <sup>6</sup> Kg/cm <sup>2</sup>	0.612 x106 Kg/cm2	
8	Joints- There shall be no joints in any wire of a stranded conductor containing continuation				
9	Co-efficient of liner expansion per deg. C	Per °C	23x10 <sup>-6</sup>		
10	Density of Material	Kg/cm <sup>3</sup>	2.7		

Maximum resistance values given have been calculated from the maximum values of the resistivity as specified and the cross-sectional area based on the minimum diameter. The minimum breaking load is calculated on nominal diameter at ultimate tensile strength of 0.3 09 KN / mm<sup>2</sup> for wire before stranding and 95% of the ultimate tensile strength after stranding.

#### 5. GENERAL CONSTRUCTION:

The conductors shall be constructed as per IS 398 (Part IV). The steel strands shall be uniformly grease coated as anti-corrosive agent in Dog, Coyote, Panther conductors. Neutral Lithium based Grease shall comply to IS 7623.

#### Lay Ratios for Aluminum Alloy Stranded Conductors

Number of Wires in Conductor	LAY RATIOS							
	3/6 Wire Layer		12 Wire Layer		18 Wire Layer		24 Wire Layer	
	Min	Max	Min	Max	Min	Max	Min	Max
7	10	14	---	---	---	---	---	---
19	10	16	10	14	---	---	---	---

**TPCODL**  
**TPWODL**

**TPNODL**  
**TPSODL**

**Specification No:** [ENG-GEN-4004](#)

**Specification Name:**  
SPECIFICATION FOR AAAC CONDUCTOR- 100,148,  
232 Sq.mm

## 5.1 MATERIALS.

- 5.1.1 The materials shall be as per clause 4.0 & 6.0 of IS 398 (Part IV). The Aluminum conductor strands shall be drawn from 99.5% pure electrolytic EC grade Aluminum rods.
- 5.1.2 Aluminum raw material shall be procured from NALCO, BALCO, HINDALCO and VEDANTA only.
- 5.1.3 The galvanized steel wire shall be drawn from high carbon steel rods produced by either acid or base open-hearth process, electric furnace or basic oxygen process.
- 5.1.4 Steel raw material shall be from Tata Steel, Jindal steel, SAIL, JSW only
- 5.1.5 Grease shall be from BPCL, HPCL, Balmer Lawrie only

## 5.2 SURFACE CONDITION.

Surface conditions of the conductor shall be generally as per clause 7.0 of IS 398 (Part IV). The wires used for standard conductor shall be smooth and free from imperfections, such as spills and split the conductor shall be free from points, sharp edges, abrasions and other departures from smoothness on uniformity of surface contour that would increase radio interference and corona losses. When subjected to tension up to 50% of the ultimate strength of the conductor, the surface shall not depart from the cylindrical form on any part of the compartment, parts or strands, more relative to each other in such a way as to get out of place and disturb the longitudinal smoothness of the conductor.

## 6. MARKING:

Each drum shall have the following information stenciled on it in indelible ink along with other essential data:

- a) Contract/Award letter number
- b) Name and address of consignee.
- c) Manufacture's name and address.
- d) Drum and lot number
- e) Size and type of conductor
- f) Length of conductor in meters
- g) Arrow marking for unwinding
- h) Position of the conductor ends
- i) Number of turns in the outer most layer.
- j) Gross weight of the drum after putting lagging.
- k) Average weight of the drum without lagging.

ISI mark Manufacturer Name/ Trade Mark

"TPCODL/TPNODL/TPSODL/TPWODL" P.O No and Date



Specification No: [ENG-GEN-4004](#)

Specification Name:  
SPECIFICATION FOR AAAC CONDUCTOR- 100,148,  
232 Sq.mm

## 7. TESTS:

The bidder shall be required to submit complete set of the following test reports along with the offer:

### 7.1 ACCEPTANCE TESTS: Acceptance Test on Finished Conductor

- i. Lay Ratio/Direction of the lay Mechanical Properties
- ii. Diameter
- iii. Breaking Load / Tensile Test
- iv. Resistance
- v. Wrapping Test
- vi. Elongation
- vii. Density Test (using Hygrometer)

### 7.2 ROUTINE TESTS

- i. Check for Joints
- ii. Surface Condition of the strand and stranded conductor
- iii. All acceptance tests
- iv. Check the drum

### 7.3 TYPE TESTS

Type Test of Finished Conductor

- i) UTS test on stranded conductor Mechanical Properties
- ii) DC resistance test on stranded conductor

## 8. TYPE TEST CERTIFICATES:

The Bidder shall furnish the type test certificates for the tests as mentioned above as per the corresponding standards. All the tests shall be conducted at **CPRI/ ERDA/ Approved Govt. Labs by TATA ODISHA DISCOM** as per relevant IS. Type tests should have been conducted during the period not exceeding 10 years from the date of opening the bid. In the event of any discrepancy in the test reports, i.e., any test report not acceptable, same shall be carried out without any cost implication to TPCODL/TPNODL/TPSODL/TPWODL.

## 9. PRE-DISPATCH INSPECTION:

The material shall be subject to inspection by a duly authorized representative of the TPCODL/TPNODL/TPSODL/TPWODL. Inspection may be made at any stage of manufacture at the discretion of the purchaser and the equipment, if found unsatisfactory as to workmanship or material, the same is liable to rejection. Bidder shall grant free access to the places of manufacture to TPCODL/TPNODL/TPSODL/TPWODL's representatives at all times when the work is in progress. Inspection by the TPCODL/TPNODL/TPSODL/TPWODL or its authorized representatives shall not

**TPCODL**  
**TPWODL**

**TPNODL**  
**TPSODL**

**Specification No:** [ENG-GEN-4004](#)

**Specification Name:**  
SPECIFICATION FOR AAAC CONDUCTOR- 100,148,  
232 Sq.mm

relieve the bidder of his obligation of furnishing equipment in accordance with the specifications. Material shall be dispatched after specific MDCC (Material Dispatch Clearance Certificate) is issued by TPCODL/TPNODL/TPSODL/TPWODL.

Following documents shall be sent along with material.

- a) Test reports
- b) MDCC issued by TPCODL/TPNODL/TPSODL/TPWODL
- c) TPCODL/TPNODL/TPSODL/TPWODL Invoice in duplicate
- d) Packing list
- e) Drawings & catalogue
- f) Guarantee / Warrantee card
- g) Delivery Challan
- h) Other Documents (as applicable).

#### **10. INSPECTION AFTER RECEIPT AT STORE:**

The material received at TPCODL/TPNODL/TPSODL/TPWODL store will be inspected for acceptance and shall be liable for rejection, if found different from the reports of the pre-dispatch inspection and one copy of the report shall be sent to Project Engineering department.

#### **11. GUARANTEE:**

Bidder shall stand guarantee towards design, materials, workmanship & quality of process/manufacturing of items under this contract for due and intended performance of the same, as an integrated product delivered under this contract. In the event any defect is found by the Purchaser up to a period of at least 12 months from the date of commissioning or 24 months from the date of last supplies made under the contract whichever is later, (the time scale of 12/24 months could be enhanced subject to mutual agreements). Bidder shall be liable to undertake to replace/rectify such defects at its own costs, within mutually agreed period, and to the entire satisfaction of the Purchaser, failing which the Purchaser will be at liberty to get it replaced/rectified at Bidder's risks and costs and recover all such expenses plus the Purchaser's own charges (@ 20% of expenses incurred), from the Bidder or from the "Security cum Performance Deposit" as the case may be. Bidder shall further be responsible for 'free replacement' for another period of THREE years from the end of the guarantee period for any 'Latent Defects' if noticed and reported by the Purchaser.

#### **12. PACKING AND TRANSPORT:**

Supplier shall ensure that all material covered by this specification shall be prepared for rail/road transport (local equipment) and be packed in such a manner as to protect it from damage in transit. Standard Length of the conductors is 2000 Mtrs. / as per PO terms and conditions. The bidder shall provide

**TPCODL**  
**TPWODL**

**TPNODL**  
**TPSODL**

**Specification No:** [ENG-GEN-4004](#)

**Specification Name:**  
SPECIFICATION FOR AAAC CONDUCTOR- 100,148,  
232 Sq.mm

instructions regarding handling and storage precautions to be taken at site.

**13. TENDER SAMPLE:**

Bidder shall submit the sample of 1 mtr. material during the tender evaluation process with the offer.

**14. QUALITY CONTROL:**

The bidder shall submit QAP indicating the various stages of inspection, the tests and checks which will be carried out on the material of construction, components during manufacture and bought out items and fully assembled component and equipment after finishing. As part of the plan, a schedule for stage and final inspection within the parameters of the delivery schedule shall be furnished. The Purchaser's engineer or its nominated representative shall have free access to the manufacturer's/sub-supplier's works to carry out inspections.

**15. TESTING FACILITIES:**

Supplier/ Manufacturer shall have adequate in-house testing facilities for carrying out all routine tests & acceptance tests as per relevant Indian standards.

**16. MANUFACTURING FACILITIES:**

The successful bidder shall submit the bar chart for various manufacturing activities clearly elaborating each stage, with quantity. This bar chart should be in line with the Quality assurance plan submitted with the offer.

**17. SPARES, ACCESSORIES AND TOOLS**

Not applicable.

**18. DRAWINGS AND DOCUMENTS:**

Following drawings and documents shall be submitted in line with the requirement of Tender specifications:

- a) Completely filled in Schedule "A" Guaranteed Technical Particulars & Schedule "B" Deviations
- b) Work Experience details
- c) Type test certificates.
- d) Drawing 1 Set of Hard Copy & Soft Copy PDF File containing complete information about manufacturing.



Specification No: [ENG-GEN-4004](#)

Specification Name:  
SPECIFICATION FOR AAAC CONDUCTOR- 100,148,  
232 Sq.mm

**19. SCHEDULE- "A" GUARANTEED TECHNICAL PARTICULARS: To Be Furnished by Bidder**

SL. NO	TECHNICAL PARTICULARS	UNIT	DOG (100 Sq.mm) (7 / 4.26mm)	COYOTE (148 Sq.mm) (19 / 3.15mm)	PANTHER (232 Sq.mm) (19 / 3.94mm)
<b>1</b>	<b>Make</b>				
a)	Aluminium Alloy rod				
b)	Conductor				
<b>2</b>	<b>Type</b>	No/mm			
<b>3</b>	<b>Particulars of Raw material</b>				
a)	Si	%			
b)	Mg	%			
c)	FE	%			
d)	Cu	%			
e)	Mn	%			
f)	Cr.	%			
g)	Zn	%			
h)	B	%			
i)	Other Elements (Each)	%			
j)	Other Elements (Total)	%			
k)	Aluminium	%			
<b>4</b>	<b>Aluminium Alloy wire Strands</b>				
i	Diameter (mm)				
a)	Normal	mm			
b)	Maximum	mm			
c)	Minimum	mm			
ii	Cross Section Area of Nominal dia wire	Sq. mm			
iii	Minimum Breaking Load of each strand after stranding	KN			
iv	Minimum elongation % on gauge length of 200 mm (After Strand)	%			





**TPCODL**  
**TPWODL**

**TPNODL**  
**TPSODL**

Specification No: [ENG-GEN-4004](#)

Specification Name:  
SPECIFICATION FOR AAAC CONDUCTOR- 100,148,  
232 Sq.mm

v	Max. Resistance at 20 Deg.C	Ohm/ KM			
<b>5</b>	<b>AAAC Stranded conductor</b>				
5.1	Nominal Sectional Area	sq. m			
5.2	Overall Diameter	mm			
5.3	Approx. Mass	Kg. /Km			
5.4	Minimum Ultimate Breaking Load of Conductor	KN			
5.5	Lay ratio of conductor ((Min. / Max.)				
5.6	Calculated Max. resistance of conductor at 20° C	Ohm/ Km.			
<b>6</b>	Standard length of conductor (meter)	Mtr.			
6.1	Continuous max. current carrying capacity in still air at 40°C ambient temperature	Amp			
6.2	Temperature rises for above current				
6.3	Tolerance on standard length of Conductor (%)	%			
6.4	Direction of lay for outside layer				
<b>7</b>	<b>Modulus of Elasticity</b>	GN/Mtr <sup>2</sup>			
8	Joints-- There shall be no joints in any wire of a stranded conductor containing continuation				
9	Co-efficient of liner expansion per deg. C	°C			

 	 	<b>Specification No:</b> <a href="#">ENG-GEN-4004</a>  <b>Specification Name:</b> SPECIFICATION FOR AAAC CONDUCTOR- 100,148, 232 Sq.mm
--	--	--

10	Density of Material	Kg/ cm3	
----	---------------------	---------	--

**20. SCHEDULE “B” DEVIATIONS:**

**(TO BE ENCLOSED WITH TECHNICAL BID)**

All deviations from this specification shall be set out by the Bidders, clause by Clause in this schedule. Unless specifically mentioned in this Schedule, the tender shall be deemed to confirm the purchaser's specifications:

SL. No	Clause No.	Details of deviation with justifications

We confirm that there are no deviations apart from those detailed above.

Seal of the Company:

Signature

Designation







**Specification No:** ENG-GEN-4021

**Specification Name:** Technical Specification of  
GI nut and bolt

## CONTENTS

1. SCOPE
2. APPLICABLE STANDARDS
3. CLIMATIC CONDITIONS OF THE INSTALLATION
4. GENERAL TECHNICAL REQUIREMENTS
5. GENERAL CONSTRUCTIONS
6. MARKING
7. TESTS
8. TYPE TEST CERTIFICATES
9. PRE-DISPATCH INSPECTION
10. INSPECTION AFTER RECEIPT AT STORES
11. GUARANTEE
12. PACKING
13. TENDER SAMPLE
14. QUALITY CONTROL
15. TESTING FACILITIES
16. MANUFACTURING ACTIVITIES
17. SPARES, ACCESSORIES AND TOOLS
18. DRAWINGS AND DOCUMENTS
19. SCHEDULE "A" GUARANTEED TECHNICAL PARTICULARS
20. SCHEDULE "B" DEVIATIONS

   	<b>Specification No:</b> ENG-GEN-4021  <b>Specification Name:</b> Technical Specification of GI nut and bolt
--	--

**1. SCOPE:**

This specification covers the design, manufacture, testing and supply of GI Nuts and Bolts to be used in structures. Scope also includes transportation & unloading at store / site.



**2. APPLICABLE STANDARDS:**

The equipment covered by this specification shall unless otherwise stated, be designed, manufactured and tested in accordance with the latest editions of the following Indian, International Standards and shall conform to the regulations of the local authorities:

IS: 1363/ Part-I & III	Hexagon Head Bolts, Screws and Nuts of Product Grade C Part 1: Hexagon Head Bolts (Size Range M 5 to M 64) Part 3: Hexagon Nuts (Size Range M5 to M64)
IS 14394	Industrial Fasteners - Hexagon Nuts of Product Grade C - Hot-Dip Galvanized (Size Range M12 to M36)
IS 1367/ Part- III, VI & XIII	Technical Supply Conditions for Threaded Steel Fasteners, Part 3: Mechanical Properties of Fasteners Made of Carbon Steel and Alloy Steel - Bolts, Screws and Studs Part 6: Mechanical Properties and Test Methods for Nuts with Specified Proof Loads Part 13: Mechanical Properties of Fasteners Made of Carbon Steel and Alloy Steel - Bolts, Screws and Studs
IS 2633	Methods for testing uniformity of coating of zinc coated articles
IS 4759	Hot-dip zinc coatings on structural steel and other allied products
IS 6745	Method for determination of mass of zinc coating on zinc coated iron and steel articles

**3. CLIMATIC CONDITIONS OF THE INSTALLATION:**

1	Maximum ambient temperature	50 deg C
2	Max. Daily average ambient temp	35 deg C
3	Min Ambient Temperature	0 deg C
4	Maximum Humidity	95%
5	Average Annual Rainfall	150cm
6	Average No. of rainy days per annum	120
7	Altitude above MSL not exceeding	1000m

   	<b>Specification No:</b> ENG-GEN-4021  <b>Specification Name:</b> Technical Specification of GI nut and bolt
--	--

8	Wind Pressure	300 Km/hr
9	Earthquakes of an intensity in horizontal direction	equivalent to seismic acceleration of 0.3g
10	Earthquakes of an intensity in vertical direction	equivalent to seismic acceleration of 0.15g (g being acceleration due to gravity)

TPCODL/TPNODL/TPSODL/TPWODL service area has heavy saline conditions along the coast and High cyclonic Intensity winds with speed upto 300 Kmph. The atmosphere is generally laden with mild acid and dust in suspension during the dry months and is subjected to fog in cold months.

#### 4. GENERAL TECHNICAL REQUIREMENTS:

SL. NO.	TECHNICAL PARTICULARS	DESIRED VALUE
1	Material details	Hot-Dip Galvanized Nut, Bolt & Washer
2	Material	Carbon steel
3	Relevant Standard	IS:1363, IS 1367, IS: 2633, IS: 2629.
4	Grade of Steel	5.6
5	Mass of Zinc Coating	As per IS 1367 Part XIII
6	Zinc Coating Thickness	As per IS 1367 Part XIII
7	Chemical Properties	C:-0.13-0.55 Max P:-0.05 Max S:- 0.06 Max B:-0.003 Max
8	Tensile Load	Table 6 of IS 1367 Part III

#### 5. GENERAL CONSTRUCTION:

Bolts & Nuts should be strictly supplied confirming to IS-1363/Part-I & III. The Bolt and Nut should be hot dip galvanized. The Chemical Composition should be as per IS 1367 Part-III.

#### 6. MARKING:

Following distinct non-erasable embossing is to be made on each Nut and Bolt to be supplied to TPCODL/TPNODL/TPSODL/TPWODL under this Tender.

- a) Manufacturer's name
- b) Grade of steel
- c) Year of manufacturing

#### 7. TESTS:

The bidder shall be required to submit complete set of the following test reports along with the



**Specification No:** ENG-GEN-4021

**Specification Name:** Technical Specification of  
GI nut and bolt

offer:-

### 7.1 ACCEPTANCE TESTS

- i) Visual Inspection
- ii) Verification of Dimensions
- iii) Checking of threads,
- iv) Galvanization Test
- v) Proof Load Test
- vi) Hardness Test
- vii) Surface Integrity Test

### 7.2 ROUTINE TESTS

Same as Acceptance Test

### 7.3 TYPE TESTS

- i) Visual Inspection
- ii) Verification of Dimensions
- iii) Checking of threads,
- iv) Galvanization Test

### 8. TYPE TEST CERTIFICATES:

The Bidder shall furnish the type test certificates for the tests as mentioned above as per the corresponding standards. All the tests shall be conducted at **CPRI / ERDA / Other Government Labs** as per relevant IS. Type tests should have been conducted during the period not exceeding 5 years from the date of opening the bid. In the event of any discrepancy in the test reports, i.e. any test report not acceptable, same shall be carried out without any cost implication to TPCODL/TPNODL/TPSODL/TPWODL.

### 9. PRE-DISPATCH INSPECTION:

The material shall be subject to inspection by a duly authorized representative of the TPCODL/TPNODL/TPSODL/TPWODL. Inspection may be made at any stage of manufacture at the discretion of the purchaser and the equipment, if found unsatisfactory as to workmanship or material, the same is liable to rejection. Bidder shall grant free access to the places of manufacture to TPCODL/TPNODL/TPSODL/TPWODL representatives at all times when the work is in progress. Inspection by the TPCODL/TPNODL/TPSODL/TPWODL or its authorized



**Specification No:** ENG-GEN-4021

**Specification Name:** Technical Specification of  
GI nut and bolt

representatives shall not relieve the bidder of his obligation of furnishing equipment in accordance with the specifications. Material shall be dispatched after specific MDCC (Material Dispatch Clearance Certificate) is issued by TPCODL/TPNODL/TPSODL/TPWODL.

Following documents shall be sent along with material.

- a) Test reports
- b) MDCC issued by TPCODL/TPNODL/TPSODL/TPWODL
- c) TPCODL/TPNODL/TPSODL/TPWODL Invoice in duplicate
- d) Packing list
- e) Drawings & catalogue
- f) Guarantee / Warrantee card
- g) Delivery Challan
- h) Other Documents (as applicable).

#### **10. INSPECTION AFTER RECEIPT AT STORE:**

The material received at TPCODL/TPNODL/TPSODL/TPWODL, Odisha store will be inspected for acceptance and shall be liable for rejection, if found different from the reports of the pre-dispatch inspection and one copy of the report shall be sent to Engineering department.

#### **11. GUARANTEE:**

Bidder shall stand guarantee towards design, materials, workmanship & quality of process/ manufacturing of items under the contract for due and intended performance of the same, as an integrated product delivered under this contract. In the event any defect is found by the Company up to a period of 12 months from the date of commissioning or 18 months from the date of last supplies made under the contract, whichever is earlier, supplier shall be liable to undertake to replace/rectify such defects at his own costs. within mutually agreed timeframe, and to the entire satisfaction of the Company, failing which the Company will be at liberty to get it replaced/rectified at supplier's risks and costs and recover all such expenses plus the Company's own charges (@ 20% of expenses incurred), from the supplier or from the "Security cum Performance Deposit" as the case may be.

#### **12. PACKING:**

Supplier shall ensure that all material covered by this specification shall be prepared for rail/road transport (local equipment) and be packed in such a manner as to protect it from damage in transit. The bidder shall provide instructions regarding handling and storage precautions to be

**Specification No:** ENG-GEN-4021

**Specification Name:** Technical Specification of GI nut and bolt

taken at site.

**13. TENDER SAMPLE:**

Bidder shall submit the sample of material during submission of Bids.

**14. QUALITY CONTROL:**

The bidder shall submit QAP indicating the various stages of inspection, the tests and checks which will be carried out on the material of construction, components during manufacture and bought out items and fully assembled component and equipment after finishing. As part of the plan, a schedule for stage and final inspection within the parameters of the delivery schedule shall be furnished. The Purchaser's engineer or its nominated representative shall have free access to the manufacturer's/sub-supplier's works to carry out inspections.

**15. TESTING FACILITIES:**

Supplier/ Manufacturer shall have adequate in house testing facilities for carrying out all routine tests & acceptance tests as per relevant Indian standards.

**16. MANUFACTURING FACILITIES:**

The successful bidder shall submit the bar chart for various manufacturing activities clearly elaborating each stage, with quantity. This bar chart should be in line with the Quality assurance plan submitted with the offer.

**17. SPARES, ACCESSORIES AND TOOLS**

Not applicable.

**18. DRAWINGS AND DOCUMENTS:**

Following drawings and documents shall be submitted in line with the requirement of Tender specifications:

- a) Completely filled in Schedule "A" Guaranteed Technical Particulars & Schedule "B" Deviations
- b) Work Experience details
- c) Type test certificates.
- d) Drawing 1 set of Hard Copy & Soft copy PDF File containing complete information about manufacturing.

**19. SCHEDULE- "A" GUARANTEED TECHNICAL PARTICULARS:-**

SL. NO.	TECHNICAL PARTICULARS	TO BE FURNISHED BY BIDDER
1	Material	
2	Relevant Standard	

   	<b>Specification No:</b> ENG-GEN-4021  <b>Specification Name:</b> Technical Specification of GI nut and bolt
--	--

3	Grade of Steel	
4	Mass of Zinc Coating	
5	Zinc Coating Thickness	
6	Chemical Properties	
7	Tensile Load	

**20. SCHEDULE "B" DEVIATIONS:**

**(TO BE ENCLOSED WITH TECHNICAL BID)**

All deviations from this specification shall be set out by the Bidders, clause by Clause in this schedule. Unless specifically mentioned in this Schedule, the tender shall be deemed to confirm the purchaser's specifications:

SL. No	Clause No.	Details of deviation with justifications

We confirm that there are no deviations apart from those detailed above.

Seal of the Company:

Signature

Designation

**CONTENTS**

1. SCOPE
2. APPLICABLE STANDARDS
3. CLIMATIC CONDITIONS OF THE INSTALLATION
4. GENERAL TECHNICAL REQUIREMENTS
5. GENERAL CONSTRUCTIONS
6. MARKING
7. TESTS
8. TYPE TEST CERTIFICATES
9. PRE-DISPATCH INSPECTION
10. INSPECTION AFTER RECEIPT AT STORES
11. GUARANTEE
12. PACKING
13. TENDER SAMPLE
14. QUALITY CONTROL
15. TESTING FACILITIES
16. MANUFACTURING ACTIVITIES
17. SPARES, ACCESSORIES AND TOOLS
18. DRAWINGS AND DOCUMENTS
19. SCHEDULE "A" GUARANTEED TECHNICAL PARTICULARS
20. SCHEDULE "B" DEVIATIONS



**1. SCOPE:**

This specification covers the design, manufacture, testing and supply of GI Structural Items includes Channel, Angles and Top brackets to be used in Structures. Scope also includes transportation & unloading at store / site.

**2. APPLICABLE STANDARDS:**

The equipment covered by this specification shall unless otherwise stated, be designed, manufactured and tested in accordance with the latest editions of the following Indian, International Standards and shall conform to the regulations of the local authorities:

IS 2062	Hot Rolled Medium and High Tensile Structural Steel
IS 1852	Rolling and Cutting Tolerances for Hot Rolled Steel products
IS 2633	Methods for testing uniformity of coating of zinc coated articles
IS 4759	Hot-dip zinc coatings on structural steel and other allied products
IS 6745	Method for determination of mass of zinc coating on zinc coated iron and steel articles

**3. CLIMATIC CONDITIONS OF THE INSTALLATION:**

SL. NO.	CONDITONS	VALUES
1	Max. altitude above sea level	1200m
2	Max. Ambient Temperature	50 °C
3	Max. Daily average ambient temp	35 °C
4	Min Ambient Temp	0 °C
5	Maximum temperature attainable by an object exposed to sun	60 °C
6	Maximum Humidity	95%
7	Minimum Humidity	10%
8	Average No. of thunderstorm days per annum	70
9	Average Annual Rainfall	150 cm
10	Average No. of rainy days per annum	120
11	Thermal Resistivity of soil	150 Deg. Ccm/W

SL. NO.	CONDITIONS	VALUES
12	Wind Pressure	126 kg/sq. m up to an elevation of 10 meter.
14	Earthquakes of intensity in horizontal direction	equivalent to seismic acceleration of 0.3g
15	Earthquakes of intensity in vertical direction	equivalent to seismic acceleration of 0.15g
16	Wind velocity	300 km/hr.

Environmentally, some of the regions, where the work will take place include coastal areas, subject to high relative humidity, which can give rise to condensation. Onshore winds will frequently be salt laden. On occasions, the combination of salt and condensation may create pollution conditions for outdoor insulators. Some places are in heavily industrial polluted areas. Therefore, Outdoor material and equipment shall be designed and protected for use in exposed, heavily polluted, salty, corrosive and humid coastal atmosphere.

The atmosphere is generally laden with mild acid and dust in suspension during the dry months and is subjected to fog in cold months. The design of equipment and accessories shall be suitable to withstand seismic forces corresponding to an acceleration of 0.1 g.

#### 4. GENERAL TECHNICAL REQUIREMENTS:

SL. NO.	TECHNICAL PARTICULARS	DESIRED VALUE			
		100X50X5 mm	75X40x4.8 mm	65X65X6 mm	50X50X6 mm
1	Material	Hot-Dip Galvanized Channel	Hot-Dip Galvanized Channel	Hot-Dip Galvanized Angle	Hot-Dip Galvanized Angle
2	Relevant Standard	IS: 2062, IS: 2633, IS: 2629, IS: 4759	IS: 2062, IS: 2633, IS: 2629, IS: 4759	IS: 2062, IS: 2633, IS: 2629, IS: 4759	IS: 2062, IS: 2633, IS: 2629, IS: 4759
3	Make	SAIL, JINDAL, RINL & TATA (Billet with re rolling not allowed)			
4	Grade of Steel	E 250 A	E 250 A	E 250 A	E 250 A
5	Minimum Tensile Strength in Mpa	410	410	410	410
6	Yield Stress in Mpa	250	250	250	250
7	Percentage Elongation (Min.) at Gauge Length	23%	23%	23%	23%

SL. NO.	TECHNICAL PARTICULARS	DESIRED VALUE			
		100X50X5 mm	75X40x4.8 mm	65X65X6 mm	50X50X6 mm
8	Bend Test (Internal Dia)	Min-2t	Min-2t	Min-2t	Min-2t
9	Mass of Zinc Coating	Min 705 gm/m <sup>2</sup>	Min 705 gm/m <sup>2</sup>	Min 705 gm/m <sup>2</sup>	Min 705 gm/m <sup>2</sup>
10	Zinc Coating Thickness & No of Dips	Min. 100 Micron at every point with 6 Dips	Min. 100 Micron at every point with 6 Dips	Min. 100 Micron at every point with 6 Dips	Min. 100 Micron at every point with 6 Dips
11	Chemical composition	Grade: E 250 A (As per IS: 2062)	Grade: E 250 A (As per IS: 2062)	Grade: E 250 A (As per IS: 2062)	Grade: E 250 A (As per IS: 2062)
12	Standard length of supply For Channel and Angles only	6 Metre Long			
13	Tolerances	As per IS 1852 latest Amendment			

## 5. GENERAL CONSTRUCTION:

The Chemical composition and Physical properties of the finished material shall be as per the equivalent standards. Chemical Composition and Physical Properties shall conforming to IS: 2062. The approved makes are SAIL, JINDAL, RINL & TATA (Billet with re rolling not allowed). Mass of the Channel and Angles are as follows:-

- 100x50x5 mm:- 9.56kg/m
- 75x40x4.8 mm:- 7.14kg/m
- 65x65x6 mm:- 5.8kg/m
- 50x50x6 mm:-4.5kg/m

### 5.1 CHEMICAL COMPOSITION

Chemical composition for E 250 A Grade

- C - 0.23% Max
- Mn - 1.5% Max
- S - 0.045% Max
- P - 0.045%Max
- SI - 0.40% Max
- CE (Carbon Equivalent)- 0.42%

## 5.2 Galvanization:

All the channels and angles shall be hot dip galvanized, are as following:

- a) All galvanizing shall be carried out by the hot dip process, in accordance with Specification IS 2629.
- b) The zinc coating (Min 705 gms per sq.mt / Min. 100 Micron at every point with 6 Dips) shall be smooth, continuous and uniform. It shall be free from acid spot and shall not scale, blister or be removable by handling or packing.
- c) There shall be no impurities in the zinc or additives to the galvanic bath which could have a detrimental effect on the durability of the zinc coating. Purity of zinc shall be Zn 99.95% or better.
- d) In the event of damage to the galvanizing the method used for repair shall be subject to the approval of the Engineer in Charge or that of his representative. Repair of galvanization at site will not be permitted in any situation.
- e) Partial immersion of the work shall not be permitted and the galvanizing tank must therefore be sufficiently large to permit galvanizing to be carried out by one immersion.
- f) After galvanizing no drilling or welding shall be performed on the galvanized parts. To avoid the formation of white rust galvanized materials shall be stacked during transport and stored in such a manner as to permit adequate ventilation. Sodium dichromate treatment shall be provided to avoid formation of white rust after hot dip galvanization. The galvanized steel shall be subjected to test as per IS-2633.
- g) Quality of Hot Dip Galvanization should comply with IS 2629, ISO 1461 & should be guaranteed for any type of damage due to harsh climatic condition for 5 Years. These channels and angles are to be used in coastal areas of Odisha where climate is hot, humid & saline. These areas are prone to flood & frequent rainfall.

## 6. MARKING:

Following distinct non-erasable embossing is to be made on each Channel and Angles and top Bracket to be supplied to TPCODL/TPNODL/TPWODL/TPSODL under this Tender.

- a) Manufacturer Name/ Trade Mark
- b) E-250 A

Engraved Marking (Punching before galvanization)

- a) "TPCODL/TPNODL/TPWODL/TPSODL"
- b) Year of manufacturing
- c) PO Number

## 7. TESTS:

The bidder shall be required to submit complete set of the following test reports along with the offer:

### 7.1 ACCEPTANCE TESTS

- i) Chemical Composition
- ii) Mechanical Properties
- iii) Dimension Test & Weight (kg/M) Visual Examination,
- iv) Test in respect of Hot Dip Galvanization i.e. Thickness of zinc coating in microns
- v) Mass of Zinc Test

### 7.2 ROUTINE TESTS

Same as Acceptance Test

### 7.3 TYPE TESTS

- i) Chemical Composition
- ii) Mechanical Properties
- iii) Test in respect of Hot Dip Galvanization i.e. thickness of zinc coating in microns

## 8. TYPE TEST CERTIFICATES:

The Bidder shall furnish the type test certificates for the tests as mentioned above as per the corresponding standards. All the tests shall be conducted at **CPRI/ERDA** as per relevant IS. However, TPCODL/ TPWODL/ TPNODL/ TPSODL. TATA-POWER reserves the right to allow any other NABL accredited/ Govt. lab report under exceptional circumstances after due diligence/ scrutiny by DISCOM. Type tests should have been conducted during the period not exceeding 5 years from the date of opening the bid. In the event of any discrepancy in the test reports, i.e. any test report not acceptable, same shall be carried out without any cost implication to TPCODL/ TPWODL/ TPNODL/ TPSODL.

## 9. PRE-DISPATCH INSPECTION:

The material shall be subject to inspection by a duly authorized representative of the TPCODL/TPNODL/TPWODL/TPSODL. Inspection may be made at any stage of manufacture at the discretion of the purchaser and the equipment, if found unsatisfactory as to workmanship or material, the same is liable to rejection. Bidder shall grant free access to the places of manufacture to TPCODL/TPNODL/TPWODL/TPSODL's representatives at all times when the work is in progress. Inspection by the TPCODL/TPNODL/TPWODL/TPSODL or its authorized

representatives shall not relieve the bidder of his obligation of furnishing equipment in accordance with the specifications. Material shall be dispatched after specific MDCC (Material Dispatch Clearance Certificate) is issued by TPCODL/TPNODL/TPWODL/TPSODL.

Following documents shall be sent along with material.

- a) Test reports
- b) MDCC issued by TPCODL/TPNODL/TPWODL/TPSODL
- c) TPCODL/TPNODL/TPWODL/TPSODL Invoice in duplicate
- d) Packing list
- e) Drawings & catalogue
- f) Guarantee / Warrantee card
- g) Delivery Challan
- h) Other Documents (as applicable).

#### **10. INSPECTION AFTER RECEIPT AT STORE:**

The material received at TPCODL/TPNODL/TPWODL/TPSODL, Odisha store will be inspected for acceptance and shall be liable for rejection, if found different from the reports of the pre-dispatch inspection and one copy of the report shall be sent to Engineering department.

#### **11. GUARANTEE:**

Bidder shall stand guarantee towards design, materials, workmanship & quality of process/manufacturing of items under the contract for due and intended performance of the same, as an integrated product delivered under this contract. In the event any defect is found by the Company up to a period of 54 months from the date of commissioning or 60 months from the date of last supplies made under the contract, whichever is earlier, supplier shall be liable to undertake to replace/rectify such defects at his own costs. within mutually agreed timeframe, and to the entire satisfaction of the Company, failing which the Company will be at liberty to get it replaced/rectified at supplier's risks and costs and recover all such expenses plus the Company's own charges (@ 20% of expenses incurred), from the supplier or from the "Security cum Performance Deposit" as the case may be.

Galvanization Guarantee- Quality of Hot Dip Galvanization should be guaranteed for any type of damage due to harsh climatic condition for 5 Years.

#### **12. PACKING:**

Supplier shall ensure that all material covered by this specification shall be prepared for rail/road transport (local equipment) and be packed in such a manner as to protect it from damage in transit. The bidder shall provide instructions regarding handling and storage precautions to be

taken at site.

**13. TENDER SAMPLE:**

The Bidder shall provide 1 no. sample of the product. The product will be accepted only if it meets all specifications as defined in the document.

**14. QUALITY CONTROL:**

The bidder shall submit QAP indicating the various stages of inspection, the tests and checks which will be carried out on the material of construction, components during manufacture and bought out items and fully assembled component and equipment after finishing. As part of the plan, a schedule for stage and final inspection within the parameters of the delivery schedule shall be furnished. The Purchaser's engineer or its nominated representative shall have free access to the manufacturer's/sub-supplier's works to carry out inspections.

**15. TESTING FACILITIES:**

Supplier/ Manufacturer shall have adequate in house testing facilities for carrying out all routine tests & acceptance tests as per relevant Indian standards.

**16. MANUFACTURING FACILITIES:**

The successful bidder shall submit the bar chart for various manufacturing activities clearly elaborating each stage, with quantity. This bar chart should be in line with the Quality assurance plan submitted with the offer.

**17. SPARES, ACCESSORIES AND TOOLS**

Not applicable.

**18. DRAWINGS AND DOCUMENTS:**

Following drawings and documents shall be submitted in line with the requirement of Tender specifications:

- a) Completely filled in Schedule "A" Guaranteed Technical Particulars & Schedule "B" Deviations
- b) Work Experience details
- c) Type test certificates.
- d) Drawing 1 set of Hard Copy & Soft copy PDF File containing complete information about manufacturing.



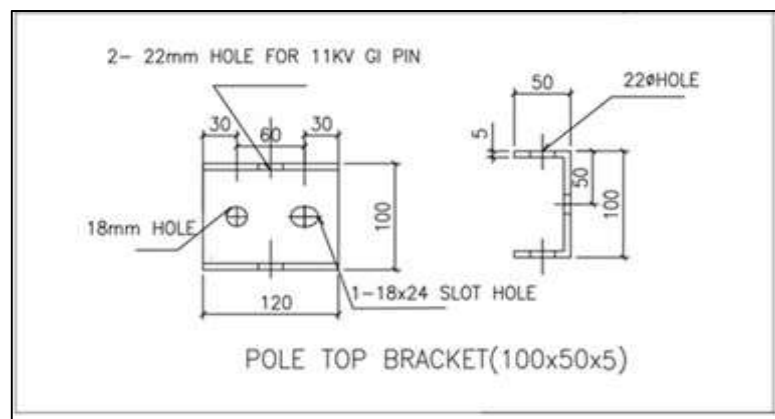
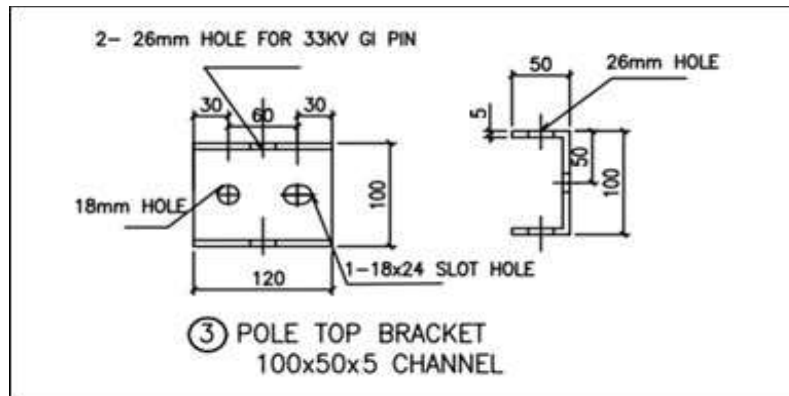

**Note:-** The Drawing is for Tender Purpose Only.

**19. SCHEDULE- "A" GUARANTEED TECHNICAL PARTICULARS:**

SL. NO.	TECHNICAL PARTICULARS	To Be Furnished By The Bidder			
		100X50X5 mm	75X40x4.8 mm	65X65X6 mm	50X50X6 mm
1	Material				
2	Relevant Standard				
4	Make				
5	Grade of Steel				
6	Minimum Tensile Strength in Mpa				
7	Yield Stress in Mpa				
8	Percentage Elongation (Min.) at Gauge Length				
9	Bend Test (Internal Dia)				
10	Mass of Zinc Coating				



SL. NO.	TECHNICAL PARTICULARS	To Be Furnished By The Bidder			
		100X50X5 mm	75X40x4.8 mm	65X65X6 mm	50X50X6 mm
11	Zinc Coating Thickness & No of Dips				
12	Standard length of supply for channel and angles only				
13	Tolerances				

**20. SCHEDULE "B" DEVIATIONS:**

**(TO BE ENCLOSED WITH TECHNICAL BID)**

All deviations from this specification shall be set out by the Bidders, clause by Clause in this schedule. Unless specifically mentioned in this Schedule, the tender shall be deemed to confirm the purchaser's specifications:

SL. No	Clause No.	Details of deviation with justifications

We confirm that there are no deviations apart from those detailed above.

Seal of the Company:

Signature

Designation

## **CONTENTS**

1. SCOPE
2. APPLICABLE STANDARDS
3. CLIMATIC CONDITIONS OF THE INSTALLATION
4. GENERAL TECHNICAL REQUIREMENTS
5. GENERAL CONSTRUCTIONS
6. MARKING
7. TESTS
8. TYPE TEST CERTIFICATES
9. PRE-DISPATCH INSPECTION
10. INSPECTION AFTER RECEIPT AT STORES
11. GUARANTEE
12. PACKING
13. TENDER SAMPLE
14. QUALITY CONTROL
15. TESTING FACILITIES
16. MANUFACTURING ACTIVITIES
17. SPARES, ACCESSORIES AND TOOLS
18. DRAWINGS AND DOCUMENTS
19. SCHEDULE "A" GUARANTEED TECHNICAL PARTICULARS
20. SCHEDULE "B" DEVIATIONS

## 1. SCOPE

The Specification covers the design, manufacture, testing preferably at manufacturer's works before supply and delivery of combined unit of hardware fittings for string insulators suitable for use in 33kV and 11kV overhead power lines.

The combined units offered shall be complete with all components which are necessary (excepting disc insulator) or usual for their effective performance and easy maintenance and inter changeability at site. Such parts shall be deemed to be within the scope of contract.

## 2. APPLICABLE STANDARDS

The equipment covered by this specification shall unless otherwise stated, be designed, manufactured and tested in accordance with the latest editions of the following Indian, International Standards and shall conform to the regulations of the local authorities:

Ref. IS	Description
IS 2486 (Part 1) IS 2486 (Part 2) IS 2486 (Part 3)	Specification for metal fittings of insulators for overhead power lines with nominal voltage greater than 1000 V. Specification for Insulator fittings for overhead power lines with nominal voltage greater than 1000V. (dimensional requirements) Specification for Insulator fittings for overhead power lines with nominal voltage greater than 1000 V. (locking devices)
IS 4759	Specification for hot-dip zinc coatings on structural steel and other allied products.
IS : 6745	Determination of mass of zinc coating on zinc coated iron and steel articles.
IS : 2633	Method for testing uniformity of coating on zinc coated.
IS 6603	Stainless Steel Bars and Flats
IS 2016	Plain washers
IS:1573	Specification for electroplated coatings of zinc on iron and steel.
IS 209	Specification of Zinc
IS 6639, BS:916	Specification for Hexagonal bolts and nuts

### 3. CLIMATIC CONDITIONS OF THE INSTALLATION:

SL.NO.	CONDITONS	VALUES
1	Max. altitude above sea level	1200m
2	Max. Ambient Temperature	50 °C
3	Max. Daily average ambient temp	35 °C
4	Min Ambient Temp	0 °C
5	Maximum temperature attainable by an object exposed to sun	60 °C
6	Maximum Humidity	95%
7	Minimum Humidity	10%
8	Average No. of thunderstorm days per annum	70
9	Average Annual Rainfall	150 cm
10	Average No. of rainy days per annum	120
11	Thermal Resistivity of soil	150 Deg. Ccm/W
12	Wind Pressure	126 kg/sq. m up to an elevation of 10 meter.
14	Earthquakes of intensity in horizontal direction	equivalent to seismic acceleration of 0.3g
15	Earthquakes of intensity in vertical direction	equivalent to seismic acceleration of 0.15g
16	Wind velocity	300 km/hr.

TPCODL/TPNODL/TPSODL/ TPWODL service area **has heavy saline conditions along the coast and High cyclonic Intensity winds with speed up to 300 Km ph.** The atmosphere is generally laden with mild acid, dust in suspension during the dry months, and is subjected to fog in cold months.

### 4. GENERAL TECHNICAL REQUIREMENTS:

- i) All ferrous parts including fasteners shall be hot dip galvanized, after all machining has been completed. Nuts may however be tapped (threaded) after galvanizing and the threads oiled. Spring washers shall be electro-galvanized. The bolt threads shall be undercut to take care of the increase in diameter due to galvanizing. Galvanizing shall be done in accordance with IS-2629-1985 and shall satisfy the tests mentioned in IS: 2633-1986. Fasteners shall

withstand four dips while spring washers shall withstand three dips of one-minute duration in the standard Preece test. Other galvanized materials shall be guaranteed to withstand at least six successive dips each lasting one minute under the Standard Preece test for galvanizing.

- ii) The zinc coating shall be perfectly adherent of uniform thickness, smooth, reasonably bright, continuous and free from imperfections such as flux, ash, rust stains, bulky white deposits and blisters. The zinc used for galvanizing shall be of grade Zn 99.95 as per IS 209.

SL. NO.	TECHNICAL PARTICULARS	DESIRED VALUE		
1	Type	<b>B&amp;S type</b>		
2	Ultimate Strength	70 KN (3 Bolted)	90 KN (4 Bolted)	120 KN (4 Bolted)
3	Suitable for conductor Size	AAAC-80 Sq mm, 100 Sq mm	AAAC-148 Sq mm	AAAC-232 Sq mm
4	Slip strength of tension clamp	95% of UTS	95% of UTS	95% of UTS
5	Referred IS Standard	IS 2486	IS 2486	IS 2486
6	Material Used			
a)	Cross Arm Strap	Mild Steel (HDG)	Mild Steel (HDG)	Mild Steel (HDG)
b)	Ball Eye	16mm Forged Steel	20mm Forged Steel	20mm Forged Steel
c)	Socket Eye	16 mm Forged Steel	20mm Forged Steel	20mm Forged Steel
d)	Bolted Type Tension Clamp and Keeper	Aluminum Alloy	Aluminum Alloy	Aluminum Alloy
e)	Security Clip	Stainless steel	Stainless steel	Stainless steel
f)	Split Pin	Stainless steel	Stainless steel	Stainless steel
g)	Cotter Pin and Bolt	Mild Steel (HDG)	Mild Steel (HDG)	Mild Steel (HDG)
h)	Nuts	Mild Steel (HDG)	Mild Steel (HDG)	Mild Steel (HDG)
i)	Spring Washer	Electro- galvanized	Electro- galvanized	Electro- galvanized
j)	Plain Washer	Mild Steel (HDG)	Mild Steel (HDG)	Mild Steel (HDG)
k)	Zn confirming to grade	IS 209	IS 209	IS 209
m)	Size of U Bolt	M16	M16	M16
7	Galvanizing	Min 705 g/sq meter/100 microns 6 dips	Min 705 g/sq meter/100 microns 6 dips	Min 705 g/sq meter/100 microns 6 dips
8	Tolerance	+/-5%	+/-5%	+/-5%

## 5. GENERAL CONSTRUCTIONS:

### 5.1 Fittings for Strain Insulators with clamp

- i) Cross arm strap confirming to IS 2486 (Part 2). Forged Steel ball eye for attaching the socket end of the Disc insulator to the cross arm strap. Dimensions shall be in accordance with IS: 2486 (Part-2) unless otherwise specified.
- ii) Cross-arm straps shall be manufactured from MS Flat hot dip galvanized and to connect the cross-arm/bracket of the structure at one end and the Ball Clevis at the other end.
- iii) It should be complete with hexagonal bolts, nuts, spring washers and Cotter pin at the threaded end to lock the unit. Minimum Threaded portion of the bolt shall be 30mm.
- iv) Aluminum alloy thimble socket made of permanent high strength aluminum alloy for attaching the disc insulator at one end and for accommodating the loop of conductor at the other end. The thimble socket shall be attached to the disc insulator with the help of locking pin as per the dimensions given in IS:2486 (Part 2).
- v) The tension hardware with three bolts and four bolts strain hardware shall have minimum slip strength not less than 95% of the strength of respective conductor.
- vi) All forgings & castings shall be of good finish and free from flaws or any other defects which may cause decrement of efficiency while in operation. The edges on the outside of the fittings such as at the ball socket & holes and the grooves shall be smooth & rounded. Sharp radius of curvature, ridges etc. which may lead to localized pressure or cause damage to the conductors in service shall be avoided. The clamp shall permit the conductor to slip before the failure of conductor occurs.
- vii) All parts of different fittings which provide for interconnection shall be made such that sufficient clearance is provided at the connection point to ensure free movement. All ball and socket connections shall be free in this manner, but care shall be taken that too much clearance between ball and socket is avoided.
- viii) All ferrous fittings and the parts other than those of stainless steel, shall be galvanized. Small fittings like spring washers, nuts, etc. should be electro-galvanized-Coating thickness as per IS: 1573.
- ix) The nominal dimensions of the ball and sockets, ball eye and cross-arm straps are as per the IS:2486 (Part 2).

### 5.2 FASTENERS: Bolts, Nuts & Washers:

- i) All bolts and nuts shall conform to IS-6639. U bolt, Hexagonal Bolt, Nut, Plain Washer and all other ferrous parts shall be Hot dip Galvanized. In case of Hot Dip Galvanization, minimum Value of Mass of zinc coating should be 705 g/m<sup>2</sup>. All bolts and nuts shall have

hexagonal heads, the heads being truly concentric, and square with the shank, which must be perfectly straight.

- ii) Flat washers and spring washers shall be provided wherever necessary and shall be of positive lock type. Spring washers shall be electro-galvanized. The thickness of washers shall conform to IS-2016.
- iii) The split pin to be used on the cotter pin shall be of Humpback type & shall be made of Stainless Steel conforming to IS: 6603 with a minimum hardness of 160 HV.
- iv) Locking devices (R Type) for ball and socket lockers shall be of Stainless Steel conforming to IS: 6603 with minimum hardness of 160 HV. The dimension shall conform to IS: 2486.

## 6. MARKING:

Each Hardware fittings shall be legibly and indelibly marked (embossing/engraved) to show the following:

- a) Name & Trade mark of the manufacturer
- b) Year of manufacturing
- c) Minimum failing load in KN
- d) "TPCODL/TPNODL/TPWODL/TPSODL"

## 7. TESTS

The bidder shall be required to submit complete set of the following test reports along with the offer: -

### 7.1 ACCEPTANCE TESTS

#### For Clamps

- i) Visual Examination Test
- ii) Chemical Composition Test
- iii) Verification of dimensions
- iv) Mechanical Test
- v) Ultimate Strength Test
- vi) Galvanizing Test
- vii) Electrical resistance test

#### On Insulator string fittings

- i) Visual Examination
- ii) Chemical Composition Test
- iii) Verification of dimensions
- iv) Ultimate Strength Test
- v) Galvanizing Test

## 7.2 ROUTINE TESTS

- i) Visual Examination Test
- ii) Mechanical Routine Test

## 7.3 TYPE TESTS

### For Clamps

- i) Visual Examination
- ii) Verification of dimensions
- iii) Slip strength tests
- iv) Ultimate Strength test
- v) Electrical resistance test
- vi) Heating Cycle test
- vii) Galvanizing/ Electroplating Test

### On Insulator string fittings except Clamps

- i) Visual Examination
- ii) Verification of dimensions
- iii) Mechanical Test
- iv) Galvanizing Test
- v) Chemical Composition Test

## 8. TYPE TEST CERTIFICATES:

The Bidder shall furnish the type test certificates of the for the tests as mentioned above as per the corresponding standards. All the tests shall be conducted at **CPRI/ERDA/Other Government Labs** as per the relevant IS/IEC. TPCODL/ TPWODL/ TPNODL/ TPSODL. TATA-POWER reserves the right to allow any other NABL accredited/ Govt. lab report under exceptional circumstances after due diligence/ scrutiny by DISCOM. Type tests should have been conducted during the period not exceeding 5 years from the date of opening the bid. In the event of any discrepancy in the test reports, i.e. any test report not acceptable, same shall be carried out without any cost implication to TPCODL/TPNODL/TPWODL/TPSODL.

## 9. PRE DISPATCH INSPECTION:

The material shall be subject to inspection by a duly authorized representative of the TPCODL/TPNODL/TPWODL/TPSODL. Inspection may be made at any stage of manufacture at the discretion of the purchaser and the equipment, if found unsatisfactory as to workmanship or material, the same is liable to rejection. Bidder shall grant free access to



the places of manufacture to TPCODL/TPNODL/TPWODL/TPSODL's representatives at all times when the work is in progress. Inspection by the TPCODL/TPNODL/TPWODL/TPSODL or its authorized representatives shall not relieve the bidder of his obligation of furnishing equipment in accordance with the specifications. Material shall be dispatched after specific MDCC (Material Dispatch Clearance Certificate) is issued by TPCODL/ TPNODL/ TPWODL/ TPSODL.

Following documents shall be sent along with material.

<<<

- a) Test reports
- b) MDCC issued by TPCODL/TPNODL/TPWODL/TPSODL
- c) Invoice in duplicate
- d) Packing list
- e) Drawings & catalogue
- f) Guarantee / Warrantee card
- g) Delivery Challan
- h) Other Documents (as applicable).

#### **10. INSPECTION AFTER RECEIPT AT STORES:**

The material received at TPCODL/TPNODL/TPWODL/TPSODL, Odisha store will be inspected for acceptance and shall be liable for rejection, if found different from the reports of the pre-dispatch inspection and one copy of the report shall be sent to Engineering department.

#### **11. GUARANTEE:**

Bidder shall stand guarantee towards design, materials, workmanship & quality of process/ manufacturing of items under the contract for due and intended performance of the same, as an integrated product delivered under this contract. In the event any defect is found by the Company up to a period of 18 months from the date of commissioning or 24 months from the date of last supplies made under the contract, whichever is earlier, supplier shall be liable to undertake to replace/rectify such defects at his own costs. within mutually agreed timeframe, and to the entire satisfaction of the Company, failing which the Company will be at liberty to get it replaced/rectified at supplier's risks and costs and recover all such expenses plus the Company's own charges (@ 20% of expenses incurred), from the supplier or from the "Security cum Performance Deposit" as the case may be.

The bidder shall further be responsible for 'free replacement' for another period of THREE years from the end of guarantee period for any 'latent defects' if noticed by the company.

**12. PACKING:**

Supplier shall ensure that all the material covered under this specification shall be prepared for rail/road transport and be packed in such a manner so as to protect the equipment from damage in transit. The material used for packing shall be environmentally friendly. Fittings for different sizes of conductors shall be packed in different boxes/gunny bags and shall be complete with their minor accessories fitted in place and colour codes on tags/fittings shall be marked to identify suitability for different sizes. The bidder shall provide instructions regarding handling and storage precautions to be taken at site.

**13. TENDER SAMPLE:**

Bidder shall submit the sample of material during submission of Bids.

**14. QUALITY CONTROL:**

The bidder shall submit with the offer Quality Assurance Plan indicating the various stages of inspection, the tests and checks which will be carried out on the material of construction, components during manufacture and bought out items and fully assembled component and equipment after finishing. As part of the plan, a schedule for stage and final inspection within the parameters of the delivery schedule shall be furnished. The Purchaser's engineer or its nominated representative shall have free access to the manufacturer's/sub-supplier's works to carry out inspections. The bidder shall ensure that the material supplied is as per the Guaranteed Technical Particulars as specified in the specifications.

**15. TESTING FACILITIES:**

Bidder shall have adequate in-house testing facilities for carrying out all routine tests & acceptance tests as per relevant International / Indian standards.

**16. MANUFACTURING ACTIVITIES:**

The bidder shall get the approved drawing and GTP before start of manufacturing activity. The successful bidder will have to submit details of the offered design & components for approval as per specification. CAT-A/CAT-B is mandatory to start manufacturing.

**17. SPARES, ACCESSORIES AND TOOLS**

Not applicable.

**18. DRAWINGS AND DOCUMENTS**

Following drawings and documents shall be submitted in line with the requirement of Tender specifications:

- a) Completely filled in Schedule "A" Guaranteed Technical Particulars & Schedule "B" Deviations

- b) Work Experience details
- c) Type test certificates.
- d) Drawing 1 set of Hard Copy & Soft copy PDF File containing complete information about manufacturing.

**19. SCHEDULE- “A” GUARANTEED TECHNICAL PARTICULARS**

Bidder to submit completely clause wise compliance of this specification.

**20. SCHEDULE “B” DEVIATIONS:**

**(TO BE ENCLOSED WITH TECHNICAL BID)**

All deviations from this specification shall be set out by the Bidders, clause by Clause in this schedule. Unless specifically mentioned in this Schedule, the tender shall be deemed to confirm the purchaser's specifications:

SL. No	Clause No.	Details of deviation with justifications

We confirm that there are no deviations apart from those detailed above.

Seal of the Company:

Signature

Designation



**Specification No:** ENG-GEN-4031

**Specification Name:** Technical Specification for Clamps & Connectors for AAAC Conductors & Equipment's

## CONTENTS

1. SCOPE
2. APPLICABLE STANDARDS
3. CLIMATIC CONDITIONS OF THE INSTALLATION
4. GENERAL TECHNICAL REQUIREMENTS
5. GENERAL CONSTRUCTIONS
6. MARKING
7. TESTS
8. TYPE TEST CERTIFICATES
9. PRE-DISPATCH INSPECTION
10. INSPECTION AFTER RECEIPT AT STORES
11. GUARANTEE
12. PACKING
13. TENDER SAMPLE
14. QUALITY CONTROL
15. TESTING FACILITIES
16. MANUFACTURING FACILITIES
17. SPARES, ACCESSORIES AND TOOLS
18. DRAWINGS AND DOCUMENTS
19. SCHEDULE "A" GUARANTEED TECHNICAL PARTICULARS
20. SCHEDULE "B" DEVIATIONS

**Specification No:** ENG-GEN-4031

**Specification Name:** Technical Specification for Clamps & Connectors for AAAC Conductors & Equipment's

### 1. SCOPE:

This specification covers the technical requirements of design, manufacture, testing at manufacturer's works, packing, forwarding, supply and unloading at site/store. Performance of Clamps & Connectors for AAAC Conductors including for breaker, isolator, CT, IVT, BPI and SA required for the switch yard with all accessories and necessary training for trouble free & efficient performance.



### 2. APPLICABLE STANDARDS:

The terminal connectors under this specification shall conform strictly to the requirements of the latest version of the following standards as amended up-to-date, except where specified otherwise.

Sl.No	IS	Description
1	IS: 5561	Specification for Electrical Power Connectors
2	IS: 617	Aluminium & Aluminium Alloy
3	IS: 2629	Recommended Practice for hot dip galvanizing of iron and steel
4	IS: 2633	Method of testing uniformity of coating of zinc coated articles. HDG- Refer to Line Hardware Items

### 3. CLIMATIC CONDITIONS:

1	Maximum ambient temperature	50 deg C
2	Max. Daily average ambient temp	35 deg C
3	Min Ambient Temperature	0 deg C
4	Maximum Humidity	95%
5	Average Annual Rainfall	150cm
6	Average No. of rainy days per annum	120
7	Altitude above MSL not exceeding	1000m
8	Wind Pressure	300 Km/hr

   	<b>Specification No:</b> ENG-GEN-4031  <b>Specification Name:</b> Technical Specification for Clamps & Connectors for AAAC Conductors & Equipment's
--	---

9	Earthquakes of an intensity in horizontal direction	equivalent to seismic acceleration of 0.3g
10	Earthquakes of an intensity in vertical direction	equivalent to seismic acceleration of 0.15g (g being acceleration due to gravity)





TPCODL/TPNODL/TPWODL/TPSODL service area has heavy saline conditions along the coast and High cyclonic Intensity winds with speed up to 300 Kmph. The atmosphere is generally laden with mild acid, dust in suspension during the dry months, and is subjected to fog in cold months.

#### 4. GENERAL TECHNICAL REQUIREMENTS:

The Connector rating shall match with the rating of the respective equipment for the terminal connectors and the connectors for bus bar and dropper should be of following rating. Minimum Thickness at any part of connector shall be at least 10 MM

##### A. TENSION CLAMPS:

Sl. No.	Details Suitable for AAAC (148/100mm <sup>2</sup> )	Requirement:
1	Type	Compression type tension clamp
2	Material	Ext. Al.Alloy/Ext. Al.
3	Breaking Strength	95% of UTS of Conductor
4	Slipping Strength	95% of UTS of Conductor
<b>5</b>	<b>Galvanizing</b>	
a	Ferrous Parts	Hot Dip Galvanized
b	Spring Washers	Electro Galvanized
<b>6</b>	<b>Quality of Zinc used</b>	99.95 %
7	Number of dips which the clamp can withstand	4/ 1 minute dips
8	Standard to which Conforming	IS 2633
9	Electrical conductivity	
a.	Results of heating cycle test carried out	
b.	Electrical resistance	Not more than 75% of equivalent length of conductor

   	<b>Specification No:</b> ENG-GEN-4031  <b>Specification Name:</b> Technical Specification for Clamps & Connectors for AAAC Conductors & Equipment's
--	---





10	Reference to type tests and other test reports attached	
11	Make of bolts and Nuts used	Standard Make

**B. SUSPENSION CLAMPS:**

Sl. No.	Details Suitable for AAAC (148/100mm <sup>2</sup> )	Requirement:
1	Type of material used for retaining rod for AGS assembly giving reference of ISS	Aluminium Alloy 6061/Equivalent
2	Minimum tensile strength of retaining rod material	35 Kg/mm <sup>2</sup>
3	Chemical composition of retaining rod materials	As per IS:733
4	Electrical conductivity of Armour Rod material(In percentage of the conductivity of IACS i.e. International Annealed Copper Standard	Not less than 40 %of IACS
5	Slipping strength of cushioned suspension assembly	8% to 15% of UTS of Conductor
6	Breaking strength of suspension Clamp	6000 Kgf
7	Minimum Tensile Strength	2000 Psi
8	Minimum ultimate Elongation	300 %
9	Ageing (guaranteed life of the assembly)	40 Years
10	Hardness	65 to 80 A

**C. FLEXIBLE COPPER BOND:**

Sl. No.	Details	Requirement:
1	Stranding	37/ 7/ 0.417
2	Cross sectional area(Sq.mm)	75.6
3	Minimum copper equivalent area(sq.mm)	34(each individual wire)
4	Length of copper cable(mm)	500

   	<b>Specification No:</b> ENG-GEN-4031  <b>Specification Name:</b> Technical Specification for Clamps & Connectors for AAAC Conductors & Equipment's
--	---

5	Material Lugs	Tinned copper
6	Bolt Size	
	(i) Diameter(mm)	16
	(ii) Length(mm)	40
7	Resistance(ohm)	0.0004(as per IS.2121)
8	Total weight of Flexible copper bond(kg)	0.45(approx.)





**D. C-type Wedge Connector**

Sl.No	Details	Requirement
1	Applicable standard	IS:5561 1970
2	<b>Metallic Material of connector</b>	
	a. 'C' Member	AL Alloy
	b. Wedge Member	AL Alloy
	Non-Metallic Material of connector	Anti-Corrosion inhibitor contain metallic abrasive grit
3	Suitable Conductor for Main & Tap	Main: 80, 100, 148 sq mm Tap: 80, 100, 148 sq mm
4	Rated voltage in KV	Upto 33 kv
5	Rated Tensile strength in kgf	110
6	Current carrying capacity	As per conductor size

**E. PG Connector**

Sl. No	Description	Units	Requirement					
	Types		<b>35sq mm</b>	<b>50-55sq mm</b>	<b>80sq mm</b>	<b>100sq mm</b>	<b>148sq mm</b>	<b>232 sq. mm</b>
1	Application		To provide connection between: Main- 16-150 sq.mm Aluminum Tap- 16-150 sq.mm Aluminum					To provide connection between: Main- 35-240 sq.mm Aluminum Tap- 35-240 sq.mm Aluminum



   	<b>Specification No:</b> ENG-GEN-4031  <b>Specification Name:</b> Technical Specification for Clamps & Connectors for AAAC Conductors & Equipment's
--	---

2.	Rated Voltage	KV	12	
3.	System Frequency	Hz	50	
4.	Tightening Torque	Nm	22 (+/-2)	29 (+/-2)
5.	Material Composition		<b>Clamp &amp; Keeper-</b> Aluminium Alloy <b>Nut,Bolt,Washers-</b> MS HDG <b>Spring Washer-</b> HDG/EG <b>Body-</b> Corrosion resistant aluminium alloy, tensile Strength 300 N/mm'. <b>Screw-</b> Hot-dip galvanized steel, strength class of 8.8 Grade Galvanizing shall be as per relevant IS standards.	
6.	Pressure Surface		Grooved or gripped jawed	
7.	Bolt		Shear head arrangement, 8.8 grade	
8.	No./Size of Bolts		2 x M8	3 x M10
9.	Overall Diameter	mm	5.1 - 15.7	7.5 - 20.3

#### 5. GENERAL CONSTRUCTION:

The terminal connectors shall be manufactured from Aluminium Silicon Alloy and conform to designation A6 of IS: 617 (latest edition).The connectors shall be of best quality and workmanship, well finished and of approved design. Specific materials for clamps and connectors should have high current carrying capacity, high corrosion resistance and be free from corona formation.

All connectors or its components to be connected with conductor shall be of bolted type having aluminium purity not less than 99.5%.All bus bar clamps shall be made preferably from forged aluminium of purity not less than 99.5%. The thickness and contact surface should be maintained in such a way that the clamp should conform to IS: 5561/1970 or any latest revision thereof



**Specification No:** ENG-GEN-4031

**Specification Name:** Technical Specification for Clamps & Connectors for AAAC Conductors & Equipment's

## 5.1 EQUIPMENT CONNECTORS

Bimetallic connectors shall be used to connect conductors of dissimilar metal. The following bimetallic arrangement shall be preferred.

a) Copper cladding of minimum 4 mm. thickness on the aluminium portion of connector coming in contact with the copper palm or stud of the equipment.

b) Alternatively, to provide cold rolled aluminium copper strip between the aluminium portion of the connection, the sheet thickness shall not be less than 2 mm

Sufficient contact pressure should be maintained at the joint by the provision of the required number of bolts or other fixing arrangements, but the contact pressure should not be so great as to cause relaxation of the joint by cold flow, the joint should be such that the pressure is maintained within this range under all conditions of service, to avoid excessive local pressure, the contact pressure should be evenly distributed by use of pressure plates, washers or suitable saddles of adequate area of thickness should be less than that of an equal length of conductor where measured individually test results showing the milli drop test and resistance should be enclosed with the bid

All connectors shall be so designed and manufactured as to offer ease of installation as these are to be used in overhead installations, design shall be such that full tightening of nuts and bolts should be possible with the use of double wrench.

## 5.2 WEDGE CONNECTOR:

The connector shall conform to Heavy Duty, Class A as per International Standard - ANSI C 119.4. It also shall conform to Indian Standard - IS 5561. It consists of a spring 'C' member and a Wedge, both made from a special tin plated copper alloy and heat treatment, which results in spring action. Both members shall be factory coated with a conductive inhibitor containing abrasive particles to help in cleaning the contact surface during installation.

They shall connect conductors of Aluminium, Copper and their alloys regardless of the combination (i.e. Al to Al, Al to Cu, Cu to Cu). These connectors shall provide a non-corrosive connection and that is protected against temperature variation and overloading. In addition, connector shall provide a reliable electrical as well as mechanical connection for solid, stranded or compacted conductor combinations including AAC, AAAC and ACSR. A good connection shall be easily verified by visual inspection. All the connectors shall be removed without damaging the conductor and the conductor as well as the connector can be used again. The connector shall be useful for the conductor size of service connections.

	<p><b>Specification No:</b> ENG-GEN-4031</p> <p><b>Specification Name:</b> Technical Specification for Clamps &amp; Connectors for AAAC Conductors &amp; Equipment's</p>
---	--

**‘C’ Member**

This shall be formed from a special Copper alloy so that the grain (extrusion direction) runs perpendicular to the conductor. This orientation of grain direction provides for lower rates of stress relaxation in the metal and will maintain the level of contact pressure at or near the value at initial installation for the life of connection. The material used shall be specially designed with close tolerances on the chemical composition to ensure consistency of the C- member production regarding dimensions & mechanical properties

**Wedge**

This also made up of special Cu alloy which is manufactured to close tolerances to ensure repeatability and reliability of the connection.

**Inhibitor**

An oxidation inhibitor shall be applied to the surface there by elimination of oxidation of metallic surface. The chemical composition of the inhibitor shall be synthetic and compatible with the rubber gloves used by the utilities. This inhibitor shall contain special conducting abrasive particles, optimized in size and quantity, to ensure repeatability and reliability of the electrical contact made in every connection.

**Freedom From Defects**

The wedge type connectors shall be smooth and free from cavities, blowholes, and such other defects, which would likely cause them to be unsatisfactory in service.

The wedge type connectors shall be so designed and proportioned that they are capable of safely withstanding stresses to which they may be subjected (including those due to short circuit and climatic conditions) and that the effects of vibration both on conductor and on connector itself are minimized.

They shall be designed, manufactured, and finished to avoid sharp radius of curvature, ridges and excrescences, which might lead to, localized pressure on or damage to the conductor in service.

The joint should be such that the pressure is maintained within this range under all conditions of service.

**5.3 PG Connector**

Aluminum Parallel Groove connectors i.e. connector designed for connecting two or more conductors whose axes are parallel to each other. These connectors are composed of Metal Oxide parts, an upper body and Lower body. They have two parallel grooves to receive the conductors. In aluminum clamps, the two bodies are made out of high strength aluminum alloy. The bolts are made out of hard steel and hot-dip galvanized with aluminum shear off head arrangement operating with normal/ordinary tools.

**6. MARKING:**

- i). Markings/Embossing- TPCODL/TPNODL/TPWODL/TPSODL,
- ii). Manufacture’s trademark
- iii). Applicable Rating



**Specification No:** ENG-GEN-4031

**Specification Name:** Technical Specification for Clamps & Connectors for AAAC Conductors & Equipment's

## 7. TESTS:

The bidder shall be required to submit complete set of the following test reports along with the offer:

### 7.1 ACCEPTANCE TESTS:

- i) Tensile Test
- ii) Resistance Test
- iii) Dimensional Check
- iv) Galvanizing Test, where Applicable

### 7.2 ROUTINE TEST:

- i) Visual Inspection
- ii) Dimensional Check

### 7.2 TYPE TESTS (As per relevant IS/IEC)

- i) Tensile Test
- ii) Resistance Test
- iii) Temperature Rise Test
- iv) Short time Current Test
- v) Dimensional Check
- vi) Galvanising Test

## 8. TYPE TEST CERTIFICATES:

The Bidder shall furnish the type test certificates for the tests as mentioned above as per the corresponding standards. All the tests shall be conducted at **CPRI/ERDA/Other Govt. Lab** as per relevant IS. Type tests should have been conducted during the period not exceeding 5 years from the date of opening the bid. In the event of any discrepancy in the test reports, i.e. any test report not acceptable, it shall be carried out without any cost implication to TPCODL/TPNODL/TPWODL/TPSODL.

## 9. PRE-DISPATCH INSPECTION:

The material shall be subject to inspection by a duly authorized representative of the TPCODL/TPNODL/TPWODL/TPSODL. Inspection may be made at any stage of manufacture at the discretion of the purchaser and the equipment, if found unsatisfactory as to workmanship or material, the same is liable to rejection. Bidder shall grant free access to the places of manufacture to TPCODL/TPNODL/TPWODL/TPSODL's representatives at all times when the work is in progress. Inspection by the TPCODL/TPNODL/TPWODL/TPSODL or its authorized representatives shall not relieve the bidder of his obligation of furnishing equipment in accordance with the specifications. Material shall be dispatched after specific MDCC (Material Dispatch Clearance Certificate) is issued by TPCODL/TPNODL/TPWODL/TPSODL.

	<p><b>Specification No:</b> ENG-GEN-4031</p> <p><b>Specification Name:</b> Technical Specification for Clamps &amp; Connectors for AAAC Conductors &amp; Equipment's</p>
---	--

Following documents shall be sent along with material.

- a) Test reports
- b) MDCC issued by TPCODL/TPNODL/TPWODL/TPSODL
- c) TPCODL/TPNODL/TPWODL/TPSODL Invoice in duplicate
- d) Packing list
- e) Drawings & catalogue
- f) Guarantee / Warrantee card
- g) Delivery Challan
- h) Other Documents (as applicable).

**10. INSPECTION AFTER RECEIPT AT STORE:**

The material received at TPCODL/TPNODL/TPWODL/TPSODL store will be inspected for acceptance and shall be liable for rejection, if found different from the reports of the pre-dispatch inspection and one copy of the report shall be sent to Project Engineering department.

**11. GUARANTEE:**

Bidder shall stand guarantee towards design, materials, workmanship & quality of process/ manufacturing of items under this contract for due and intended performance of the same, as an integrated product delivered under this contract. In the event any defect is found by the Purchaser up to a period of at least 12 months from the date of commissioning or 24 months from the date of last supplies made under the contract whichever is later, (the time scale of 12/24 months could be enhanced subject to mutual agreements). Bidder shall be liable to undertake to replace/rectify such defects at its own costs, within mutually agreed time frame, and to the entire satisfaction of the Purchaser, failing which the Purchaser will be at liberty to get it replaced/rectified at Bidder's risks and costs and recover all such expenses plus the Purchaser's own charges (@ 20% of expenses incurred), from the Bidder or from the "Security cum Performance Deposit" as the case may be. Bidder shall further be responsible for 'free replacement' for another period of THREE years from the end of the guarantee period for any 'Latent Defects' if noticed and reported by the Purchaser.

**12. PACKING AND TRANSPORT:**

Supplier shall ensure that all material covered by this specification shall be prepared for rail/road transport (local equipment) and be packed in such a manner as to protect it from damage in transit. The bidder shall provide instructions regarding handling and storage precautions to be taken at site.

**13. TENDER SAMPLE:**

Required

	<p><b>Specification No:</b> ENG-GEN-4031</p> <p><b>Specification Name:</b> Technical Specification for Clamps &amp; Connectors for AAAC Conductors &amp; Equipment's</p>
---	--

**14. QUALITY CONTROL:**

The bidder shall submit QAP indicating the various stages of inspection, the tests and checks which will be carried out on the material of construction, components during manufacture and bought out items and fully assembled component and equipment after finishing. As part of the plan, a schedule for stage and final inspection within the parameters of the delivery schedule shall be furnished. The Purchaser's engineer or its nominated representative shall have free access to the manufacturer's/sub-supplier's works to carry out inspections.

**15. TESTING FACILITIES:**

Supplier/ Manufacturer shall have adequate in house testing facilities for carrying out all routine tests & acceptance tests as per relevant Indian standards.

**16. MANUFACTURING FACILITIES:**

The successful bidder shall submit the bar chart for various manufacturing activities clearly elaborating each stage, with quantity. This bar chart should be in line with the Quality assurance plan submitted with the offer.

**17. SPARES, ACCESSORIES AND TOOLS**

Not applicable.

**18. DRAWINGS AND DOCUMENTS:**

Following drawings and documents shall be submitted in line with the requirement of Tender specifications:

- a) Completely filled in Schedule "A" Guaranteed Technical Particulars & Schedule "B" Deviations
- b) Work Experience details
- c) Type test certificates.
- d) Drawing 1 Set of Hard Copy & Soft Copy PDF File containing complete information about manufacturing.

**19. SCHEDULE- "A" GUARANTEED TECHNICAL PARTICULARS: To be furnished by Bidder**

**19.1 TENSION CLAMPS**

SI. No.	Details	<u>To be furnished by Bidder</u>
	<b>Suitable for AAAC (148/100mm<sup>2</sup>)</b>	
1	Type	
2	Material	
3	Breaking Strength	
4	Slipping Strength	

**TPCODL****TPNODL****TPWODL****TPSODL****Specification No:** ENG-GEN-4031**Specification Name:** Technical Specification for Clamps & Connectors for AAAC Conductors & Equipment's

5	Galvanising	
a	Ferrous Parts	
b	Spring Washers	
6	Quality of Zinc used	
7	Number of dips which the clamp can withstand	
8	Standard to which Conforming	
9	Electrical conductivity	
a.	Results of heating cycle test carried out	
b.	Electrical resistance	
10	Reference to type tests and other test reports attached	
11	Make of bolts and Nuts used	

**19.2 SUSPENSION CLAMPS**

<b>Sl. No.</b>	<b>Details</b>	<b><u>To be furnished by Bidder</u></b>
	<b>Suitable for AAAC (148/100mm<sup>2</sup>)</b>	
1	Type of material used for retaining rod for AGS assembly giving reference of ISS	
2	Minimum tensile strength of retaining rod material	
3	Chemical composition of retaining rod materials	
4	Electrical conductivity of Armour Rod material(In percentage of the conductivity of IACS i.e. International Annealed Copper Standard	
5	Slipping strength of cushioned suspension assembly	
6	Breaking strength of suspension Clamp	
7	Minimum Tensile Strength	
8	Minimum ultimate Elongation	
9	Ageing (guaranteed life of the assembly)	

   	<b>Specification No:</b> ENG-GEN-4031  <b>Specification Name:</b> Technical Specification for Clamps & Connectors for AAAC Conductors & Equipment's
--	---

10	Hardness	
----	----------	--

### 19.3 FLEXIBLE COPPER BOND

Sl. No.	Details (Flexible Copper Bond)	<u>To be furnished by Bidder</u>
1	Stranding	
2	Cross sectional area(Sq.mm)	
3	Minimum copper equivalent area(sq.mm)	
4	Length of copper cable(mm)	
5	Material Lugs	
6	Bolt Size	
	(iii) Diameter(mm)	
	(iv) Length(mm)	
7	Resistance(ohm)	
8	Total weight of Flexible copper bond(kg)	

### 19.4 Wedge Connector

Sl.No	Details	<u>To be furnished by Bidder</u>
1	Product designation	
2	Applicable standard	
3	<b>Metallic Material of connector</b>	
	a. 'C' Member	
	b. Wedge Member	
	c. Hardware	
4	Non-Metallic Material of connector	
5	Suitable Conductor for Main & Tap	
6	Installation & Application tooling	
7	Rated voltage in KV	
8	Rated Tensile strength in kgf	
9	Rated voltage in KV	

### 19.5 PG Connector

Sl. No	Details	To be furnished by bidder
--------	---------	---------------------------



   	<b>Specification No:</b> ENG-GEN-4031  <b>Specification Name:</b> Technical Specification for Clamps & Connectors for AAAC Conductors & Equipment's
--	---

<b>1.</b>	Suitable size of main conductor	
<b>2.</b>	Suitable size of branch conductor	
<b>3.</b>	Rated Voltage	
<b>4.</b>	System Frequency	
<b>5.</b>	Tightening Torque	
<b>6.</b>	Material Composition	
<b>7.</b>	Pressure surfaces	

**20. SCHEDULE “B” DEVIATIONS:**

**(TO BE ENCLOSED WITH TECHNICAL BID)**

All deviations from this specification shall be set out by the Bidders, clause by Clause in this schedule. Unless specifically mentioned in this Schedule, the tender shall be deemed to confirm the purchaser's specifications:

SL. No	Clause No.	Details of deviation with justifications

We confirm that there are no deviations apart from those detailed above.

Seal of the Company:

Signature

Designation



**Specification No:** ENG-HV-2015

**Specification Name:** Technical Specification for  
11KV Lightning Arrester (10 KA)

## CONTENTS

1. SCOPE
2. APPLICABLE STANDARDS
3. CLIMATIC CONDITIONS OF THE INSTALLATION
4. GENERAL TECHNICAL REQUIREMENTS
5. GENERAL CONSTRUCTIONS
6. MARKING
7. TESTS
8. TYPE TEST CERTIFICATES
9. PRE-DISPATCH INSPECTION
10. INSPECTION AFTER RECEIPT AT STORES
11. GUARANTEE
12. PACKING
13. TENDER SAMPLE
14. QUALITY CONTROL
15. TESTING FACILITIES
16. MANUFACTURING FACILITIES
17. SPARES, ACCESSORIES AND TOOLS
18. DRAWINGS AND DOCUMENTS
19. SCHEDULE "A" GUARANTEED TECHNICAL PARTICULARS
20. SCHEDULE "B" DEVIATIONS

**1. SCOPE:**

This specification covers the design, manufacture, testing and supply of 12kV, 10kA, Station class-SL, (class-II) Metal Oxide Gap less Polymeric Lightning Arrester. The specific requirements are covered in the enclosed technical data sheet. Some of the parts that may have not been specifically included, but otherwise form part of the Lightning arrester as per standard practice or necessary for proper operation, will be deemed to be also included in this specification. The successful bidder shall not be eligible for any extra charges for such accessories etc. Scope also includes transportation & unloading at store / site.

**2. APPLICABLE STANDARDS:**

The equipment covered by this specification shall unless otherwise stated, be designed, manufactured and tested in accordance with the latest editions of the following Indian, International Standards and shall conform to the regulations of the local authorities:

IEC 60099-4	Specification for surge arrestor without gap for AC System
IS 15086	Specification for Metal Oxide Gap less Lightning arresters for alternating current System
IS 6209	Method of Partial Discharge Measurement
IS 8704 & IS 731	Guide for selection of creepage distance of polymeric housing insulator.
ISO 48	Rubber, vulcanized or thermoplastic -- Determination of hardness (hardness between 10 IRHD and 100 IRHD).
IEC 60721-3-2	Classification of environmental conditions. Classification of groups of environmental parameters and their severities. Transportation
IEC 60071	Insulation co-ordination -- Part 1 definitions, principles and rules; -- Part 2: Application Guide
IEC 60815-1	Selection and dimensioning of high-voltage insulators intended for use in polluted conditions –Part 1: Definitions, information and general principles
IS 2629	Recommended Practice for Hot-Dip Galvanizing of Iron and Steel
IS 2633	Methods for testing uniformity of coating of zinc coated articles
IS 4759	Hot-dip zinc coatings on structural steel and other allied products

### 3. CLIMATIC CONDITIONS:

1	Maximum ambient temperature	50 deg C
2	Max. Daily average ambient temp	35 deg C
3	Min Ambient Temperature	0 deg C
4	Maximum Humidity	95%
5	Average Annual Rainfall	150mm
6	Average No. of rainy days per annum	120
7	Altitude above MSL not exceeding	1000m
8	Wind Pressure	300 Km/hr
9	Earthquakes of an intensity in horizontal direction	equivalent to seismic acceleration of 0.3g
10	Earthquakes of an intensity in vertical direction	equivalent to seismic acceleration of 0.15g (g being acceleration due to gravity)

TPCODL/TPWODL/TPNODL/TPSODL service area has heavy saline conditions along the coast and High cyclonic Intensity winds with speed upto 300 Kmph. The atmosphere is generally laden with mild acid and dust in suspension during the dry months and is subjected to fog in cold months.

### 4. GENERAL TECHNICAL REQUIREMENTS:

SL. NO.	TECHNICAL PARTICULARS (Class-SL,Class-II)	DESIRED VALUE
1	Installation	Outdoor
2	Reference standards (Latest Amend.)	IS 15086,Part-4, IEC 60099
3	Arrester Type and Housing	Metal Oxide Gapless Cage type with Polymeric housing
4	Normal System Voltage	11 kV
5	Highest System Voltage	12 kv
6	Rated Frequency	50 Hz
7	Maximum Continuous Operating Voltage (M.C.O.V)	9.6 kV (rms)
8	Arrester Rating	12 kV (rms)
9	<b>Discharge Current</b>	
a	Nominal Discharge Current	10 kA
b	Switching impulse discharge current	0.5kA

<b>SL. NO.</b>	<b>TECHNICAL PARTICULARS (Class-SL,Class-II)</b>	<b>DESIRED VALUE</b>
10	Short Circuit rating	25 kA
11	<b>Voltage Withstand on Arrester Housing</b>	
a	Standard rated short duration Power Frequency withstand Voltage (Dry/Wet) as per IS:2165	28kV (rms)
b	Standard rated Lightning Impulse withstand Voltage (Peak in kV)	75kV (Peak )
12	Lightning Impulse Protection Level (at 10kA)	49 kV
13	<b>Long Duration Current</b>	
a	Peak Current	75 A
b	Virtual duration of Peak T	1000 T (Micro Sec)
14	High Current impulse Operating Duty	65 kA (Peak)
15	Creepage Distance of Arrester Housing	31mm/KV (min) or 380 mm (min)
16	Partial Discharge at 1.05 times M.C.O. V	<10 pc
17	Energy Absorption capacity (KJ/KV)	>=4KJ/KV
18	Repetitive charge transfer withstand (coloumbs),Qrs	>=1.0
19	<b>Temporary over voltage (TOV)</b>	
a	1 sec	15kVp
b	10 sec	14kVp
20	<b>Maximum Lightning Impulse Residual voltage with 8/20 microsecond wave</b>	
a	at 5kA	35kVp
b	at 10kA	38kVp
c	at 20kA	--
21	<b>Maximum switching current impulse residual voltage in kVP at 500 A</b>	21 kVp
22	Max. Cantilever Strength	12 Kg-M(minimum)
23	Total height of the arrester	To be specified by bidder
24	Total weight of the arrester	To be specified by bidder
25	No. of Metal oxide blocks in arrester	To be specified by bidder
26	Rating of individual ZnO blocks used for assembly	To be specified by bidder
27	Power Losses of the Arrester in watt	To be specified by bidder
28	Type of Mounting	Bracket type
29	Material of Insulating base	UV resistant Fire retardant DMC
30	<b>Disconnecter (optional)</b>	
a	Disconnecter connecting lead	Insulated flexible tinned plated copper braid with lugs
b	Size of Insulated Tinned copper	25 sq.mm

<b>SL. NO.</b>	<b>TECHNICAL PARTICULARS (Class-SL,Class-II)</b>	<b>DESIRED VALUE</b>
	braid	
c	Length of Insulated Tinned copper braid	300 mm
31	Insulating Terminal Cap	Polyolefin
32	Material of Nuts and bolts	Stainless Steel

## 5. GENERAL CONSTRUCTION:

Lighting arrestors shall be station class, zinc oxide and gapless type suitable for operation under the system conditions specified. This shall be self-supporting, structure mounting type. Each unit of arrester assembly shall be hermitically sealed, leak tested and protected against ingress of moisture and shall be individual demountable. The seal shall be properly designed and tested for operation under extreme weather conditions.

### 5.1 Assembly:

Lighting arrester shall be supplied along with the insulating base/Mounting bracket, terminal connector, insulating terminal cap (Polyolefin) and necessary hardwares. The assembly consists of a stack of metal oxide elements arranged in cage type designs. All metal parts shall be of non-rusting and non –corroding metal. Bolts, screws and pins shall be provided with lock washers. Lightning arrester construction shall be suitable to withstand seismic loading, short circuit forces, wind load, the force exerted on the arrester base and to terminal imposed by the line conductor. All similar parts, particularly removable ones, shall be interchangeable.

- a) The 12kV 10kA station class Lightning Arrester shall have L-shaped terminal clamp suitable for conductor size of 148 sqmm.
- b) Housing shall be polymeric to provide thermal dissipation of heat generated in the metal oxide elements during over voltage and line discharge. Polymeric housing shall be free from flaws affecting the mechanical and electrical strength of the arrester. Housing shall be capable to withstand the temperature rise due to the non-uniform field distribution, caused by the pollution on the surface of the housing.
- c) The arrester shall have thermal stability to withstand the heat generated from ZnO element due to continuous operating voltages and surges. It shall remain in undamaged condition, capable protective function.
- d) Arrestors shall incorporate anticontamination feature to prevent arrester failure, consequent to uneven voltage gradient across the stack in the event of contamination of the arrester insulating material. These features shall be described in detail when submitting the Bid.

Arrestors shall be capable of discharging over voltages occurring during switching of unloaded transformers, capacitors banks and long lines. No radio interferences shall be caused by the arrestors operating at the normal rated voltage.

e) Bidder shall mention energy handling capacity.

**5.2 EARTHING TERMINALS:**

Earth Terminals shall be provided with Lightning arrester.

**5.3 MECHANICAL STRENGTH:**

a) The Lightning Arrester and it base shall withstand rated mechanical terminal load and electromagnetic forces without impairing their operational reliability.

b) The Lightning Arrester shall not come out of their positions by gravity, wind pressure, vibrations or reasonable shocks.

**5.4 DISCONNECTORS (OPTIONAL):**

a) Each Individual unit of Lightning Arrester with disconnecter shall be hermetically sealed and fully protected against ingress of moisture. The hermetic seal shall be effective for the entire life time of the Lightning Arrester with disconnecter under the specified service conditions. Disconnectors shall give the visible indication of the failed arrester. The Lightning Arrester with disconnecter shall be suitable for bracket type mounting. Disconnecter shall be suitable for screwing directly to LA with terminal of M10.

b) The corresponding units of Lightning Arrester with disconnecter of the same rating shall be interchangeable without adversely affecting the performance. All the necessary flanges, bolts, nuts, clamps etc. required for assembly of complete Lightning Arrester with disconnecter and accessories and mounting on purchaser's support structure shall be included in bidder's scope of supply. The mounting details for mounting the Lightning Arrester with disconnecter on purchaser's support shall be given along with bid.

**5.5 MOUNTING BRACKET:**

a) The 12kV 10kA Distribution class Lightning Arrester shall be fixed over a mounting bracket made of UV resistance, Fire retardant DMC material.

b) The 12kV 10kA Station class Lightning Arrester shall be fixed over a mounting arrangement made of Hot dip galvanized MS material.

**6. MARKING:**

A stainless steel rating plate, of at least 1 mm thickness, shall be fitted to each Lightning Arrester in a visible position and shall carry all the information as specified in the standards. The letters on the rating plate shall be engraved black on the white/silver background. Fixing screws for outdoor use shall be of stainless steel or any other corrosion resistant metals. The Name plate shall be embossed with "PO no. with date" & "TPCODL/TPWODL/TPNODL/TPSODL",



**Specification No:** ENG-HV-2015

**Specification Name:** Technical Specification for  
11KV Lightning Arrester (10 KA)

The following information shall be mentioned on the Name Plate

- a) Continuous operating Voltage
- b) Rated Voltage
- c) Rated Frequency
- d) Nominal Discharge Current
- e) Pressure relief rated current in kA r.m.s.
- f) Manufacturer's Name
- g) Type and Identification of the complete
- h) Year/Month of Manufacture
- i) Serial Number.
- j) Warrantee/guarantee clause

**7. TESTS:**

All routine, acceptance & type tests shall be carried out in accordance with the relevant IS/IEC. All acceptance tests shall be witnessed by the purchaser/his authorized representative. All the components and fittings shall also be type tested as per the relevant standards. Following tests shall necessarily be conducted on lightning arrester in addition to others specified in IS/IEC standards: -

**7.1 ACCEPTANCE TESTS**

- a) Measurement of Power frequency reference voltage
- b) Lightning impulse residual voltage test on complete arrester or arrester unit.
- c) Internal Partial Discharge test
- d) Visual Examination

All acceptance tests shall be witnessed by TPCODL/TPWODL/TPNODL/TPSODL / the purchaser's or his authorized representative. The above mentioned tests shall be made on 100 % of arrestors to be supplied.

**7.2 ROUTINE TESTS**

- a) Measurement of reference voltage test
- b) Residual Voltage Test on complete arrester
- c) Internal partial discharge test. This test shall be performed on each arrester unit. The test sample may be shielded against external partial discharges. Internal partial discharge shall not exceed 10 pC





**Specification No:** ENG-HV-2015

**Specification Name:** Technical Specification for  
11KV Lightning Arrester (10 KA)

### 7.3 TYPE TESTS

- a) Insulation withstand tests, including lightning impulse voltage withstand test
- b) Residual voltage tests, including steep current impulse residual voltage test, lightning impulse residual voltage test and switching impulse residual voltage test.
- c) Operating duty tests
- d) Long duration current impulse withstand test/Repetitive charge transfer rating, Qrs.
- e) Weather ageing test
- f) Short circuit test (low/high current)
- g) Power frequency (voltage vs Time curve)
- h) Bending moment test
- i) Hot dip Galvanizing test on exposed steel parts.
- j) Internal partial discharge test
- k) Wet power frequency voltage withstand test.
- l) Seal leak rate test
- m) Tests on arrester disconnectors- Time current characteristics (optional)

### 7.4 SPECIAL THERMAL STABILITY TEST:

The test requires additional agreement between manufacturer and purchaser prior to the commencement of arrester assembly.

### 8. TYPE TEST CERTIFICATES:

The Bidder shall furnish the type test certificates for the tests as mentioned above as per the corresponding standards. All the tests shall be conducted at **CPRI/ERDA** as per relevant standard. Type tests should have been conducted during the period not exceeding 5 years from the date of opening the bid. In the event of any discrepancy in the test reports, i.e. any test report not acceptable, same shall be carried out without any cost implication to TPCODL/TPWODL/TPNODL/TPSODL.

### 9. PRE-DISPATCH INSPECTION:

The material shall be subject to inspection by a duly authorized representative of the TPCODL/TPWODL/TPNODL/TPSODL. Inspection may be made at any stage of manufacture at the discretion of the purchaser and the equipment, if found unsatisfactory as to workmanship or material, the same is liable to rejection. Bidder shall grant free access to the places of manufacture to TPCODL/TPWODL/TPNODL/TPSODL's representatives at all times when the work is in progress. Inspection by the TPCODL/TPWODL/TPNODL/TPSODL or its authorized representatives shall not relieve the bidder of his obligation of furnishing equipment in accordance



**Specification No:** ENG-HV-2015

**Specification Name:** Technical Specification for  
11KV Lightning Arrester (10 KA)

with the specifications. Material shall be dispatched after specific MDCC (Material Dispatch Clearance Certificate) is issued by TPCODL/TPWODL/TPNODL/TPSODL.

Following documents shall be sent along with material.

- a) Test reports
- b) MDCC issued by TPCODL/TPWODL/TPNODL/TPSODL
- c) TPCODL/TPWODL/TPNODL/TPSODL Invoice in duplicate
- d) Packing list
- e) Drawings & catalogue
- f) Guarantee / Warrantee card
- g) Delivery Challan
- h) Other Documents (as applicable).

#### **10. INSPECTION AFTER RECEIPT AT STORE:**

The material received at TPCODL/TPWODL/TPNODL/TPSODL, Odisha store will be inspected for acceptance and shall be liable for rejection, if found different from the reports of the pre-dispatch inspection and one copy of the report shall be sent to Engineering department.

#### **11. GUARANTEE:**

Bidder shall stand guarantee towards design, materials, workmanship & quality of process/manufacturing of items under the contract for due and intended performance of the same, as an integrated product delivered under this contract. In the event any defect is found by the Company up to a period of 18 months from the date of commissioning or 24 months from the date of last supplies made under the contract, whichever is earlier, supplier shall be liable to undertake to replace/rectify such defects at his own costs. within mutually agreed timeframe, and to the entire satisfaction of the Company, failing which the Company will be at liberty to get it replaced/rectified at supplier's risks and costs and recover all such expenses plus the Company's own charges (@ 20% of expenses incurred), from the supplier or from the "Security cum Performance Deposit" as the case may be.

The bidder shall further be responsible for ' free replacement' for another period of THREE years from the end of gurantee period for any 'latent defects' if noticed by the company.

#### **12. PACKING AND TRANSPORT:**

Bidder shall ensure that all material covered by this specification shall be prepared for rail/road transport (local equipment) and be packed in such a manner as to protect it from damage in transit. The bidder shall provide instructions regarding handling and storage precautions to be taken at site. The material should be packed in vertical position in individual box in such a way that the



**Specification No:** ENG-HV-2015

**Specification Name:** Technical Specification for 11KV Lightning Arrester (10 KA)

shape of rain shed does not get deformed during transportation and storage.

**13. TENDER SAMPLE:**

One sample to be submitted during technical bid submission. This shall be Non-returnable basis.

**14. QUALITY CONTROL:**

The bidder shall submit QAP indicating the various stages of inspection, the tests and checks which will be carried out on the material of construction, components during manufacture and bought out items and fully assembled component and equipment after finishing. As part of the plan, a schedule for stage and final inspection within the parameters of the delivery schedule shall be furnished. The Purchaser's engineer or its nominated representative shall have free access to the manufacturer's/sub-supplier's works to carry out inspections.

**15. TESTING FACILITIES:**

Bidder shall have adequate in house testing facilities for carrying out all routine tests & acceptance tests as per relevant International / Indian standards.

**16. MANUFACTURING FACILITIES:**

The successful bidder shall submit the bar chart for various manufacturing activities clearly elaborating each stage, with quantity. This bar chart should be in line with the Quality assurance plan submitted with the offer.

The successful bidder will have to submit technical compliance document and drawing as per RC line items for getting approval before mass manufacturing.

Manufacturing shall start only after getting CAT-A approved drawings or as per intimation from TPCODL/TPWODL/TPNODL/TPSODL.

**17. SPARES, ACCESSORIES AND TOOLS**

Not applicable.

**18. DRAWINGS AND DOCUMENTS:**

Following drawings and documents shall be prepared based on TPCODL/TPWODL/TPNODL/TPSODL specifications and statutory requirements and shall be submitted with the bid:

- a) Completely filled in Technical Particulars and compliance to each clause of the specification General Technical Requirements to Additional Details.
- b) Description of the equipment and all components including brochures.
- c) General Drawing arrangement of lightning arrester.
- d) Sectional drawing showing internal blocks etc.



**Specification No:** ENG-HV-2015

**Specification Name:** Technical Specification for 11KV Lightning Arrester (10 KA)

- e) Bill of material.
- f) Experience Certificate and list.
- g) Type test certificates.
- h) List of makes of major components.
- i) Foundation plan

**Drawings / documents to be submitted after the award of the contract are as under:**

**List of Drawings/Parameters to be submitted:**

- a) Technical Parameters as asked in Specification (General Technical Particulars, General Technical Requirements, Additional Details, Fittings, Type test Reports and Routine test certificates of bought out accessories).
- b) General Arrangement Drawing of the Lightning arrester (Front view and Top view. Complete list of fittings to be displayed and quantities to be mentioned with the drawing).
- c) Sectional drawing showing the blocks arrangement.
- d) Terminal and connection drawings
- e) Type Test Certificates.
- f) Installation/ Mounting Instructions/Drawing.

**Additional Documents to be submitted:**

- a) List of raw materials as well as bought out accessories and the names of sub-suppliers selected from those furnished along with offer.
- b) Type test certificates of the raw materials and bought out accessories.
- c) The successful Bidder shall submit the routine test certificates of bought out accessories and central excise passes for raw material at the time of routine testing.

All the documents & drawings shall be in English language.





After the receipt of the order, the successful bidder will be required to furnish all relevant drawings/parameters/calculation to TPCODL/TPWODL/TPNODL/TPSODL for approval.

**Instruction Manuals:**

Bidder shall furnish softcopies of nicely bound manuals (In English language) covering erection and maintenance instructions and all relevant information and drawings pertaining to the main equipment as well as auxiliary devices.

**19. SCHEDULE- "A" GUARANTEED TECHNICAL PARTICULARS:**

SL. NO.	TECHNICAL PARTICULARS (Class-SL, Class-II)	DESIRED VALUE
1	Installation	
2	Reference standards (Latest Amend.)	
3	Arrester Type and Housing	
4	Normal System Voltage	
5	Highest System Voltage	
6	Rated Frequency	
7	Maximum Continuous Operating Voltage (M.C.O.V)	
8	Arrester Rating	
9	<b>Discharge Current</b>	
a	Nominal Discharge Current	
b	Switching impulse discharge current	
10	Short Circuit rating	
11	<b>Voltage Withstand on Arrester Housing</b>	
a	Standard rated short duration Power Frequency withstand Voltage (Dry/Wet) as per IS:2165	
b	Standard rated Lightning Impulse withstand Voltage (Peak in kV)	
	Lightning Impulse Protection Level (at 10kA)	
13	<b>Long Duration Current</b>	
a	Peak Current	
b	Virtual duration of Peak T	
14	High Current impulse Operating Duty	
15	Creepage Distance of Arrester Housing	
16	Partial Discharge at 1.05 times M.C.O. V	
17	Energy Absorption capacity (KJ/KV)	
18	Repetitive charge transfer withstand (coloumbs),Qrs	
19	<b>Temporary over voltage (TOV)</b>	
a	1 sec	
b	10 sec	
20	<b>Maximum Lightning Impulse Residual voltage with 8/20 microsecond wave</b>	
a	at 5kA	
b	at 10kA	
c	at 20kA	
21	<b>Maximum switching current impulse residual voltage in kVP at 500 A</b>	
22	Max. Cantilever Strength	
23	Total height of the arrester	

   	<b>Specification No:</b> ENG-HV-2015  <b>Specification Name:</b> Technical Specification for 11KV Lightning Arrester (10 KA)
--	--

SL. NO.	TECHNICAL PARTICULARS (Class-SL, Class-II)	DESIRED VALUE
24	Total weight of the arrester	
25	No. of Metal oxide blocks in arrester	
26	Rating of individual ZnO blocks used for assembly	
27	Power Losses of the Arrester in watt	
28	Type of Mounting	
29	Material of Insulating base	
30	<b>Disconnecter (optional)</b>	
a	Disconnecter connecting lead	
b	Size of Insulated Tinned copper braid	
c	Length of Insulated Tinned copper braid	

**20. SCHEDULE "B" DEVIATIONS:**

**(TO BE ENCLOSED WITH TECHNICAL BID)**

All deviations from this specification shall be set out by the Bidders, clause by Clause in this schedule. Unless specifically mentioned in this Schedule, the tender shall be deemed to confirm the purchaser's specifications:

SL. No	Clause No.	Details of deviation with justifications

We confirm that there are no deviations apart from those detailed above.

Seal of the Company:

Signature

Designation

**CONTENTS**

1. SCOPE
2. APPLICABLE STANDARDS
3. CLIMATIC CONDITIONS OF THE INSTALLATION
4. GENERAL TECHNICAL REQUIREMENTS
5. GENERAL CONSTRUCTIONS
6. MARKING
7. TESTS
8. TYPE TEST CERTIFICATES
9. PRE-DISPATCH INSPECTION
10. INSPECTION AFTER RECEIPT AT STORES
11. GUARANTEE
12. PACKING
13. TENDER SAMPLE
14. QUALITY CONTROL
15. TESTING FACILITIES
16. MANUFACTURING ACTIVITIES
17. SPARES, ACCESSORIES AND TOOLS
18. DRAWINGS AND DOCUMENTS
19. SCHEDULE "A" GUARANTEED TECHNICAL PARTICULARS
20. SCHEDULE "B" DEVIATIONS

**1. SCOPE:**

This specification covers the design, manufacture, testing and supply of 11kV GI V Cross Arm to be used in Structures. Scope also includes transportation & unloading at store / site.

**2. APPLICABLE STANDARDS:**

The equipment covered by this specification shall unless otherwise stated, be designed, manufactured and tested in accordance with the latest editions of the following Indian, International Standards and shall conform to the regulations of the local authorities:

IS 2062	Hot Rolled Medium and High Tensile Structural Steel
IS 1852	Rolling and Cutting Tolerances for Hot Rolled Steel products
IS 2633	Methods for testing uniformity of coating of zinc coated articles
IS 4759	Hot-dip zinc coatings on structural steel and other allied products
IS 6745	Method for determination of mass of zinc coating on zinc coated iron and steel articles

**3. CLIMATIC CONDITIONS OF THE INSTALLATION:**

SL.NO.	CONDITONS	VALUES
1	Max. altitude above sea level	1200m
2	Max. Ambient Temperature	50 °C
3	Max. Daily average ambient temp	35 °C
4	Min Ambient Temp	0 °C
5	Maximum temperature attainable by an object exposed to sun	60 °C
6	Maximum Humidity	95%
7	Minimum Humidity	10%
8	Average No. of thunderstorm days per annum	70
9	Average Annual Rainfall	150 cm
10	Average No. of rainy days per annum	120
11	Thermal Resistivity of soil	150 Deg. Ccm/W



SL.NO.	CONDITIONS	VALUES
12	Wind Pressure	126 kg/sq. m up to an elevation of 10 meter.
14	Earthquakes of intensity in horizontal direction	equivalent to seismic acceleration of 0.3g
15	Earthquakes of intensity in vertical direction	equivalent to seismic acceleration of 0.15g
16	Wind velocity	300 km/hr.

TPCODL/TPNODL/TPSODL/ TPWODL service area has heavy saline conditions along the coast and High cyclonic Intensity winds with speed up to 300 Km ph. The atmosphere is generally laden with mild acid, dust in suspension during the dry months, and is subjected to fog in cold months.

#### 4. GENERAL TECHNICAL REQUIREMENTS:

SL. NO.	TECHNICAL PARTICULARS	DESIRED VALUE
1	Materials	75X40X4.8 mm Channel , 50X50X6 mm GI Plate
2	Galvanisation process	Hot-Dip Galvanized
3	Relevant Standard	IS: 2062, IS: 2633, IS: 2629, TPCO-OTH-010.
4	Make	SAIL, JINDAL, RINL & TATA (Billet with re rolling not allowed)
5	Weight of Cross Arm	10.5 KG (Approx.)
6	Grade of Steel	E 250 A
7	Minimum Tensile Strength	410 N/mm <sup>2</sup>
8	Yield Stress	250 N/mm <sup>2</sup>
9	Percentage Elongation (Min.) at Gauge Length	23%
10	Bend Test (Internal Dia)	Min-2t
11	Mass of Zinc Coating	Min 705 gm/m <sup>2</sup>
12	Zinc Coating Thickness	Min 100 micron (6 Dip)
13	Chemical composition	Grade: E 250 A (As per IS: 2062)
14	Tolerances	As per IS 1852 latest amendments

#### 5. GENERAL CONSTRUCTION:

The Chemical composition and Physical properties of the finished material shall be as per the equivalent standards. Chemical Composition and Physical Properties shall conforming to IS: 2062. The approved makes are SAIL, JINDAL, RINL & TATA (Billet with re rolling not allowed).

## 5.1 CHEMICAL COMPOSITION

Chemical composition for 250 A Grade

- a) C - 0.23% Max
- b) Mn - 1.5% Max
- c) S - 0.045% Max
- d) P - 0.045% Max
- e) SI - 0.40% Max
- f) CE (Carbon Equivalent) - 0.42%

## 5.2 Galvanization:

All 11kV V Cross Arms shall be hot dip galvanized, are as following:

- a) All galvanizing shall be carried out by the hot dip process, in accordance with Specification IS 2629.
- b) The zinc coating (Min 705 gms per sq.mt / 100Micron, 6 Dips) shall be smooth, continuous and uniform. It shall be free from acid spot and shall not scale, blister or be removable by handling or packing.
- c) There shall be no impurities in the zinc or additives to the galvanic bath which could have a detrimental effect on the durability of the zinc coating. Purity of zinc shall be Zn 99.95% or better.
- d) In the event of damage to the galvanizing the method used for repair shall be subject to the approval of the Engineer in Charge or that of his representative. Repair of galvanization at site will not be permitted in any situation.
- e) Partial immersion of the work shall not be permitted and the galvanizing tank must therefore be sufficiently large to permit galvanizing to be carried out by one immersion.
- f) After galvanizing no drilling or welding shall be performed on the galvanized parts. To avoid the formation of white rust galvanized materials shall be stacked during transport and stored in such a manner as to permit adequate ventilation. Sodium dichromate treatment shall be provided to avoid formation of white rust after hot dip galvanization. The galvanized steel shall be subjected to test as per IS-2633.
- g) Quality of Hot Dip Galvanization should comply with IS 2629, ISO 1461 & should be guaranteed for any type of damage due to harsh climatic condition for 5 Years. These V Cross Arms are to be used in coastal areas of Odisha where climate is hot, humid & saline. These areas are prone to flood & frequent rainfall.

**6. MARKING:**

Following distinct non-erasable embossing is to be made on each Channel and Angles to be supplied to TPCODL/TPWODL/TPNODL/TPSODL under this Tender.

a) Manufacturer Name/ Trade Mark

Engraved Marking (Punching before galvanization)

a) "TPCODL/TPWODL/TPNODL/TPSODL"

b) Year of manufacturing

c) PO Number

**7. TESTS:**

The bidder shall be required to submit complete set of the following test reports along with the offer:

**7.1 ACCEPTANCE TESTS**

- i) Chemical Composition
- ii) Mechanical Properties
- iii) Dimension Test & Weight (kg/M) Visual Examination,
- iv) Test in respect of Hot Dip Galvanization i.e. Thickness of zinc coating in microns

**7.2 ROUTINE TESTS**

Same as Acceptance Test

**7.3 TYPE TESTS**

- i) Chemical Composition
- ii) Mechanical Properties
- iii) Test in respect of Hot Dip Galvanization i.e. thickness of zinc coating in microns

**8. TYPE TEST CERTIFICATES:**

The Bidder shall furnish the type test certificates for the tests as mentioned above as per the corresponding standards. All the tests shall be conducted at **CPRI/ERDA/ Other Govt. Lab** as per relevant IS. However, TPCODL/ TPWODL/ TPNODL/ TPSODL. TATA-POWER reserves the right to allow any other NABL accredited/ Govt. lab report under exceptional circumstances after due diligence/ scrutiny by DISCOM. Type tests should have been conducted during the period not exceeding 5 years from the date of opening the bid. In the event of any discrepancy in the test reports, i.e. any test report not acceptable, same shall be carried out without any cost implication to TPCODL/ TPWODL/ TPNODL/ TPSODL.

**9. PRE-DISPATCH INSPECTION:**

The material shall be subject to inspection by a duly authorized representative of the TPCODL/TPWODL/TPNODL/TPSODL. Inspection may be made at any stage of manufacture at the discretion of the purchaser and the equipment, if found unsatisfactory as to workmanship or material, the same is liable to rejection. Bidder shall grant free access to the places of manufacture to TPCODL/TPWODL/TPNODL/TPSODL's representatives at all times when the work is in progress. Inspection by the TPCODL/TPWODL/TPNODL/TPSODL or its authorized representatives shall not relieve the bidder of his obligation of furnishing equipment in accordance with the specifications. Material shall be dispatched after specific MDCC (Material Dispatch Clearance Certificate) is issued by TPCODL/TPWODL/TPNODL/TPSODL. Following documents shall be sent along with material.

- a) Test reports
- b) MDCC issued by TPCODL/TPWODL/TPNODL/TPSODL
- c) TPCODL/TPWODL/TPNODL/TPSODL Invoice in duplicate
- d) Packing list
- e) Drawings & catalogue
- f) Guarantee / Warrantee card
- g) Delivery Challan
- h) Other Documents (as applicable).

**10. INSPECTION AFTER RECEIPT AT STORE:**

The material received at TPCODL/TPWODL/TPNODL/TPSODL, Odisha store will be inspected for acceptance and shall be liable for rejection, if found different from the reports of the pre-dispatch inspection and one copy of the report shall be sent to Engineering department.

**11. GUARANTEE:**

Bidder shall stand guarantee towards design, materials, workmanship & quality of process/manufacturing of items under the contract for due and intended performance of the same, as an integrated product delivered under this contract. In the event any defect is found by the Company up to a period of 12 months from the date of commissioning or 24 months from the date of last supplies made under the contract, whichever is earlier, supplier shall be liable to undertake to replace/rectify such defects at his own costs. within mutually agreed timeframe, and to the entire satisfaction of the Company, failing which the Company will be at liberty to get it replaced/rectified at supplier's risks and costs and recover all such expenses plus the Company's own charges (@ 20% of expenses incurred), from the supplier or from the "Security cum Performance Deposit" as the case may be.

Galvanization Guarantee- Quality of Hot Dip Galvanization should be guaranteed for any type of

damage due to harsh climatic condition for 5 Years.

**12. PACKING:**

Supplier shall ensure that all material covered by this specification shall be prepared for rail/road transport (local equipment) and be packed in such a manner as to protect it from damage in transit. The bidder shall provide instructions regarding handling and storage precautions to be taken at site.

**13. TENDER SAMPLE:**

The Bidder shall provide 1 no. sample of the product. The product will be accepted only if it meets all specifications as defined in the document.

**14. QUALITY CONTROL:**

The bidder shall submit QAP indicating the various stages of inspection, the tests and checks which will be carried out on the material of construction, components during manufacture and bought out items and fully assembled component and equipment after finishing. As part of the plan, a schedule for stage and final inspection within the parameters of the delivery schedule shall be furnished. The Purchaser's engineer or its nominated representative shall have free access to the manufacturer's/sub-supplier's works to carry out inspections.

**15. TESTING FACILITIES:**

Supplier/ Manufacturer shall have adequate in house testing facilities for carrying out all routine tests & acceptance tests as per relevant Indian standards.

**16. MANUFACTURING FACILITIES:**

The bidder shall get the approved drawing and GTP before start of manufacturing activity. The successful bidder will have to submit details of the offered design & components for approval as per specification. CAT-A/CAT-B is mandatory to start manufacturing.

**17. SPARES, ACCESSORIES AND TOOLS**

Not applicable.

**18. DRAWINGS AND DOCUMENTS:**

Following drawings and documents shall be submitted in line with the requirement of Tender specifications:

- a) Completely filled-in clause wise compliance of the specification
- b) Schedule "B" Deviations
- c) Work Experience details
- d) Type test certificates.
- e) Drawing 1 set of Hard Copy & Soft copy PDF File containing complete information about manufacturing.

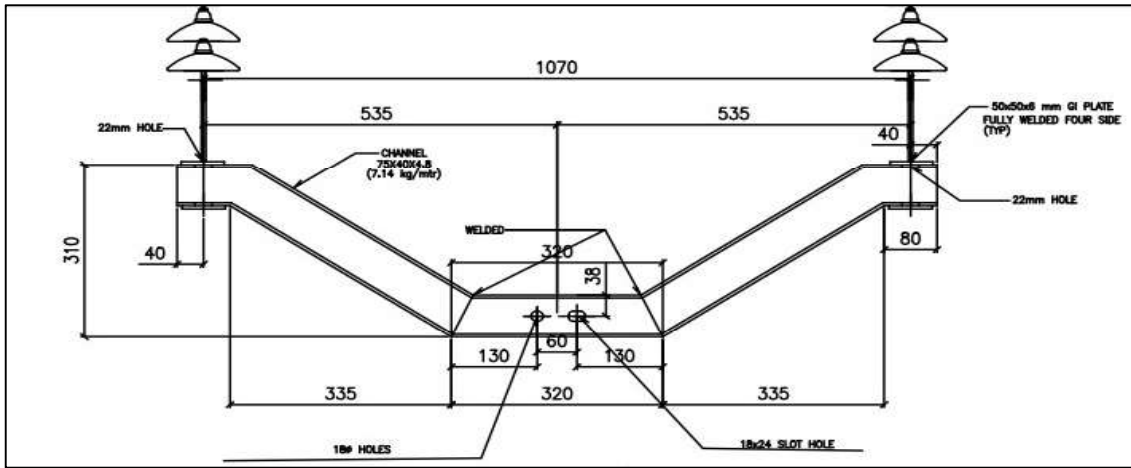

OPTION1:- Arrangement in WPB Pole

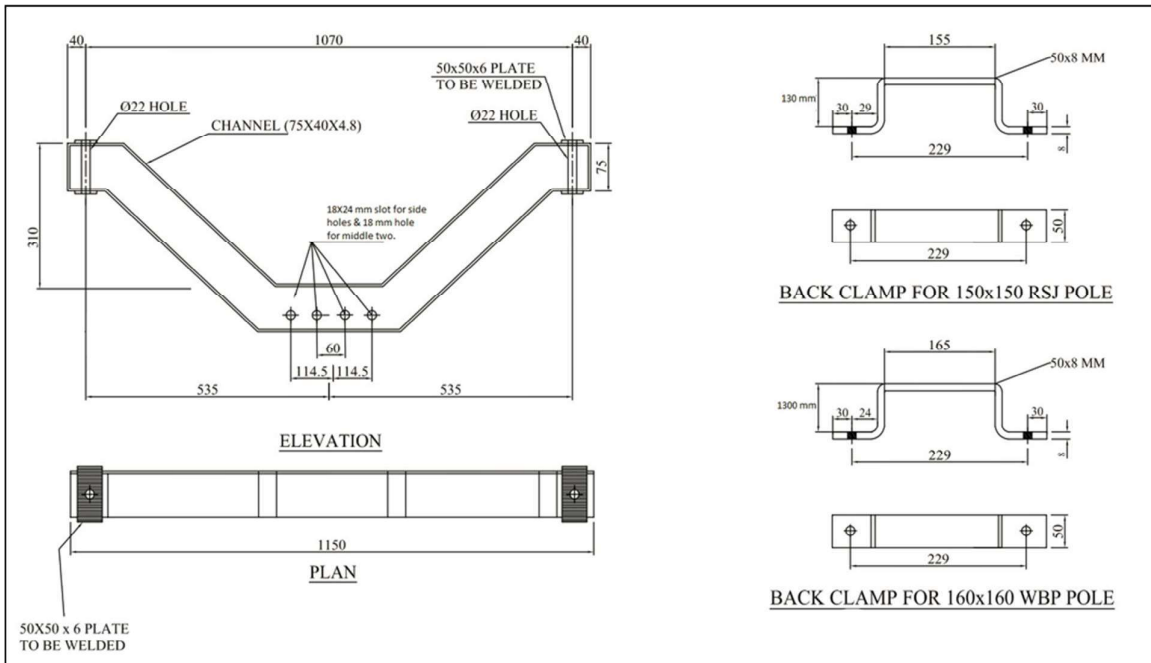

OPTION2:- Arrangement in WPB and RSJ Pole

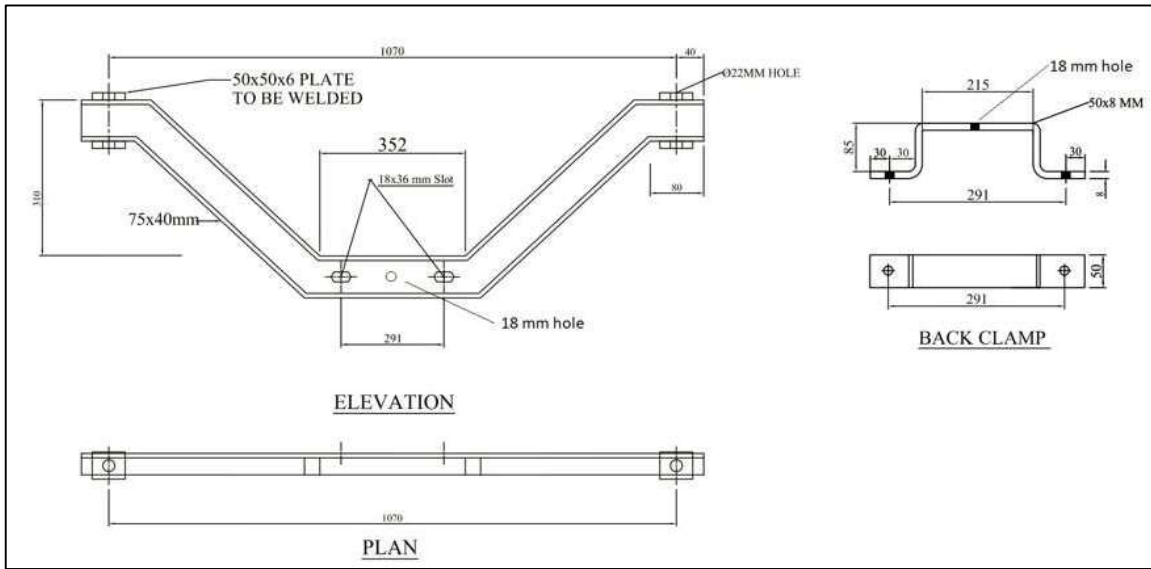

OPTION3:- Arrangement in 9 Mtr. PSC Pole

**Note:-** The drawing is for tender purpose only and indicative in nature & will be finalized during detailed engineering.

**19. SCHEDULE- "A" GUARANTEED TECHNICAL PARTICULARS:**

Bidder to submit completely clause wise compliance of this specification

**20. SCHEDULE "B" DEVIATIONS:**

**(TO BE ENCLOSED WITH TECHNICAL BID)**

All deviations from this specification shall be set out by the Bidders, clause by Clause in this schedule. Unless specifically mentioned in this Schedule, the tender shall be deemed to confirm the purchaser's specifications:

SL. No	Clause No.	Details of deviation with justifications

We confirm that there are no deviations apart from those detailed above.

Seal of the Company:

Signature

Designation

## **CONTENTS**

1. SCOPE
2. APPLICABLE STANDARDS
3. CLIMATIC CONDITIONS OF THE INSTALLATION
4. GENERAL TECHNICAL REQUIREMENTS
5. GENERAL CONSTRUCTIONS
6. MARKING
7. TESTS
8. TYPE TEST CERTIFICATES
9. PRE-DISPATCH INSPECTION
10. INSPECTION AFTER RECEIPT AT STORES
11. GUARANTEE
12. PACKING
13. TENDER SAMPLE
14. QUALITY CONTROL
15. TESTING FACILITIES
16. MANUFACTURING ACTIVITIES
17. SPARES, ACCESSORIES AND TOOLS
18. DRAWINGS AND DOCUMENTS
19. SCHEDULE "A" GUARANTEED TECHNICAL PARTICULARS
20. SCHEDULE "B" DEVIATIONS



## 1. SCOPE

The Specification covers the technical requirements of design, manufacture, test at manufacturer's works, packing & forwarding, supply and unloading at store/ site of 11 kV Pin polymer insulator 5 KN used in 11 kV Overhead Transmission lines.

## 2. APPLICABLE STANDARDS

The equipment covered by this specification shall unless otherwise stated, be designed, manufactured and tested in accordance with the latest editions of the following Indian, International Standards and shall conform to the regulations of the local authorities:

Ref. IS	Description
IEC: 61109	Definition, test methods and acceptance criteria for composite insulators for A.C. overhead lines above 1000V
IEC: 61952	Insulators for overhead lines – Composite line post insulators for alternative current systems with a nominal voltage greater than 1 000 V
IS: 2071/ IEC: 60060-1	Methods of High Voltage Testing
IS: 2486	Specification for Insulator fittings for Overhead power Lines with a nominal voltage greater than 1000V
IS: 13134/ IEC: 60815	Guide for the selection of insulators in respect of polluted condition
IS 8263/IEC: 60437	Methods of RI Test of HV insulators.
IS: 4759	Hot dip zinc coatings on structural steel & other allied products
IS: 2629	Recommended Practice for Hot, Dip Galvanization for iron and steel
IS: 2633	Testing of Uniformity of Coating of zinc coated articles
IS:6745	Method for determination of mass of zinc coating on zinc coated iron and steel articles
STRI Guide 1.92/1	Hydrophobicity Classification Guide
ASTM D 578-05	Standard specification for glass fiber strands

### 3. CLIMATIC CONDITIONS OF THE INSTALLATION:

SL.NO.	CONDITONS	VALUES
1	Max. altitude above sea level	1200m
2	Max. Ambient Temperature	50 °C
3	Max. Daily average ambient temp	35 °C
4	Min Ambient Temp	0 °C
5	Maximum temperature attainable by an object exposed to sun	60 °C
6	Maximum Humidity	95%
7	Minimum Humidity	10%
8	Average No. of thunderstorm days per annum	70
9	Average Annual Rainfall	150 cm
10	Average No. of rainy days per annum	120
11	Thermal Resistivity of soil	150 Deg. Ccm/W
12	Wind Pressure	126 kg/sq. m up to an elevation of 10 meter.
14	Earthquakes of intensity in horizontal direction	equivalent to seismic acceleration of 0.3g
15	Earthquakes of intensity in vertical direction	equivalent to seismic acceleration of 0.15g
16	Wind velocity	300 km/hr.

Environmentally, some of the regions, where the work will take place include coastal areas, subject to high relative humidity, which can give rise to condensation. Onshore winds will frequently be salt laden. On occasions, the combination of salt and condensation may create pollution conditions for outdoor insulators. Some places are in heavily industrial polluted areas. Therefore, Outdoor material and equipment shall be designed and protected for use in exposed, heavily polluted, salty, corrosive and humid coastal atmosphere.

The atmosphere is generally laden with mild acid and dust in suspension during the dry months and is subjected to fog in cold months. The design of equipment and accessories shall be suitable to withstand

seismic forces corresponding to an acceleration of 0.1 g.

#### 4. GENERAL TECHNICAL REQUIREMENTS:

- i) The Composite insulators will be used on lines on which the conductor will be ACSR/AAAC of size up to 100 Sq.mm. The insulators should withstand the conductor tension, the reversible wind load as well as the high frequency vibrations due to wind.
- ii) Insulator shall be suitable for 3 Phase, 50 Hz effectively earthed 11KV Overhead Distribution System in a moderately/heavily polluted atmosphere.
- iii) **Bidder must be indigenous manufacturer and supplier of Composite insulator of rating 11kV** or above or must have developed proven in house technology and manufacturing process for composite insulators of above rating or possess technical collaboration/association with the manufacturer of composite insulators of rating 11kV or above. The Bidder shall furnish necessary evidence in support of the above along with the bid which can be in the form of certification from Utilities concerned, or any other documents to the satisfaction of the Owner.
- iv) Insulators shall have sheds with good self-cleaning properties. Insulator shed profile, spacing, projection etc. and selection in respect of polluted conditions shall be generally in accordance with the commendation of IEC- 60815/ IS: 13134.
- v) The tolerances on all dimensions e.g. diameter, length and creepage distance shall be allowed as follows in line with-IEC 61109:
  - $\pm (0.04d + 1.5)$  mm when  $d \leq 300$  mm
  - $\pm (0.025d+6)$  mm when  $d > 300$  mm

Where, d being the dimensions in millimetres for diameter, length or creepage distance as the case may be. **However, no negative tolerance shall be applicable to creepage distance.**
- vi) The composite insulators including the end fitting connection shall be standard design suitable for use with the hardware fittings of any make conforming to relevant IEC/IS standards.
- vii) All surfaces shall be clean, smooth, without cuts, abrasions or projections. No part shall be subjected to excessive localized pressure. The insulator and metal parts shall be so designed and manufactured that it shall avoid local corona formation and not generate any radio interference beyond specified limit under the operating conditions.

SL. NO.	TECHNICAL PARTICULARS	DESIRED VALUE
1	Type of insulator	11 kV Polymeric composite Pin Insulator
2	Reference Standard	IEC 61109
3	Material of FRP Rod	Borron free ECR
4	Material of sheds	High voltage grade Silicone rubber Wacker-Germany, Dow Corning-USA
5	Material of End Fittings	SGCI /MCI/FORGED STEEL
6	Material of sealing compound	RTV Silicon
7	Colour of sheds	Grey
8	Rated system voltage	11 KV
9	Highest system voltage	12 KV
10	Dry Power Frequency Withstand voltage	70 KV
11	Wet Power Frequency Withstand voltage	35 KV
12	Dry Lightning Impulse withstand voltage	Positive: 75 KV Negative: 75 KV
13	Dry Lightning Impulse Flashover voltage	Positive: 95 KV Negative: 95 KV
14	RIV at 1 MHz when energized at 10 KV / 30 KV (rms) under dry condition	< 50 microvolt
15	Creepage distance (min)	320 mm
16	Min Failing load/ SCL (Specified cantilever Load)	5 KN
17	Dia of FRP Rod	24 mm
18	Length of FRP Rod (min)	200 mm
19	Dia of weather sheds	≥90 mm
20	Thickness of housing	3 mm
21	Dry arc distance(min)	165 mm
22	Method of fixing sheds to housing	Injection moulding
23	Visible Discharge Voltage	9 kV
24	Type of sheds	Aerodynamic
25	Dia of bottom end fitting	20 mm
26	Thread length of bottom end fitting	150 mm (Min)

#### 5. GENERAL CONSTRUCTIONS:

Polymeric Insulators shall consist of THREE parts, at least two of which are insulating parts:

- (a) Core- the internal insulating part
- (b) Housing- the external insulating part
- (c) Metal end fittings.

## 5.1 CORE

It shall be a glass-fibre reinforced epoxy resin rod of high strength (FRP rod). Glass fibres and resin shall be optimized in the FRP rod. Glass fibres shall be Boron free electrically corrosion resistant (ECR) glass fibre and shall exhibit both high electrical integrity and high resistance to acid corrosion. The matrix of the FRP rod shall be Hydrolysis resistant. The FRP rod shall be manufactured through Pultrusion process. The FRP rod shall be void free. Electrically Corrosion Resistant (ECR) grade fibre glass reinforced plastic (FRP) rod having at least 80% fibres by weight.

## 5.2 POLYMER HOUSING:

The FRP rod shall be covered by a seamless sheath of high voltage grade Silicone rubber housing of thickness 3mm minimum. It shall be one- piece housing using only Injection Moulding process to cover the core. The housing shall be designed to provide the necessary creepage distance and protection against environmental influences, external pollution and humidity. Housing shall conform to the requirements of IEC 60815 with latest amendments. All surfaces shall be clean, smooth, without cuts, abrasions or projections. No part shall be subjected to excessive localized pressure. The insulator and metal parts shall be so designed and manufactured that it shall avoid local corona formation and not generate any radio interference beyond specified limit under the operating condition. It shall be extruded or directly moulded on core and shall have chemical bonding with the FRP rod. The strength of the bond shall be greater than the tearing strength of the polymer. Sheath material in the bulk as well as in the sealing / bonding area shall be free from voids.

## 5.3 WEATHERSHEDS

The composite polymer weather sheds made of high voltage grade Silicone rubber polymer shall be moulded as part of the sheath and shall be free from imperfections. It should protect the FRP rod against environmental influences, external pollution and humidity. The weather sheds should have **silicon content of minimum 40% by weight**. The strength of the weather shed to sheath interface shall be greater than the tearing strength of the polymer. The interface, if any, between sheds and sheath (housing) shall be free from voids. Housing and weather sheds material shall have tensile strength of 3 Mpa with 400% elongation minimum and tear strength of 16 N/mm.

## 5.4 HARDWARE FITTINGS:

End fitting transmit the mechanical load to the core. They shall be made of spheroidal graphite cast iron, malleable cast iron or forged steel or aluminium alloy. Metal end fitting

shall be suitable for pin type hardware support of respective specified mechanical load and shall be hot dip galvanized in accordance with IS 2629. They shall be connected to the rod by means of a controlled compression technique. The outer of end fittings should be machined to make the surface uniform round to ensure effective sealing when housing is moulded over it. The material used in fittings shall be corrosion resistant. As the main duty of the end fittings is the transfer of mechanical loads to the core the fittings should be properly attached to the core by a coaxial or hexagonal compression process & should not damage the individual fibres or crack the core. The gap between fittings and sheath shall be sealed by flexible silicone elastomeric compound or silicone alloy compound sealant, system of attached of end fitting to the rod shall provide superior sealing performance between housing, i.e. seamless sheath and metal connection. The sealing must be moisture proof. The dimensions of end fittings of insulators shall be in accordance with the standard dimensions stated in IS: 2486 - Part-II. Outer portion of Pin should be Zinc sleeved with minimum 99.95% purity of Electrolytic high grade zinc. Bottom end fitting should be single unit without any joints. Nuts as per IS 1363 (P-III) and spring washer shall be as per IS 3063 with Latest amendments if any, Nuts and spring washer shall be hot dip galvanized. The design of the insulator shall be such that stresses due to expansion and contraction in any part of the insulator shall not lead to deterioration. The pin insulator shall not engage directly with hard metal.

## 6. MARKING:

Each insulator shall be legibly and indelibly marked (embossing/engraved) to show the following:

- a) Name & Trade mark of the manufacturer
- b) Voltage Grade
- c) Year of manufacture
- d) Minimum failing load in KN
- e) "TPCODL/TPNODL/TPWODL/TPSODL" Name should be mentioned on each insulator

## 7. TESTS

The bidder shall be required to submit complete set of the following test reports along with the offer: -

### 7.1 ACCEPTANCE TESTS

- i) Verification of dimensions

- ii) End Sealing test (FRP rod and Silicone rubber housing)
- iii) Visual examination (Free from voids, cavity, foreign particle and scratch/nick spot)
- iv) Verification of the locking system or the tightness of the interface between end fitting and insulator housing
- v) Galvanizing Test
- vi) Verification of the specified mechanical load
- vii) Bending Load Test
- viii) Dry Power Frequency Withstand Voltage Test
- ix) Wet Power Frequency Withstand Voltage Test
- x) Analysis of material properties of housing material
- xi) Analysis of material properties of Core material

## 7.2 ROUTINE TESTS

- i) Visual examination (Free from voids, cavity, foreign particle and scratch/nick spot)
- ii) Mechanical Load Test (bending/cantilever)

## 7.3 TYPE TESTS

### A) For Insulators

- i) Dry Power Frequency Withstand Voltage Test
- ii) Dry Power Frequency Voltage Flashover Test
- iii) Dry lightning impulse withstand voltage test.
- iv) Wet Power Frequency Withstand Voltage Test
- v) Wet Power Frequency Voltage Flashover Test
- vi) Mechanical failing load test.
- vii) Salt fog test: On insulators for 1000 hr as per IEC
- viii) Galvanization test
- ix) Radio interference test.

### B) For Silicon rubber

- i) Tensile Strength
- ii) Elongation
- iii) Tear Strength
- iv) Inclined plane Tracking & Erosion resistance test
- v) Volume Resistivity
- vi) Dielectric constant
- vii) Dielectric Strength

- viii) Density
- ix) Hardness
- x) Arc Resistance
- xi) Silicone Content
- xii) Flammability
- xiii) Limiting oxygen index test
- xiv) Resistance to weathering & UV.
- xv) Specific gravity

**C) For FRP rods**

- i) Verification of dimensions
- ii) Specific Gravity
- iii) Glass Content
- iv) Water Diffusion Test
- v) Hardness
- vi) Dye Penetration Test
- vii) Flexural Strength
- viii) Brittle fracture resistance test.

**8. TYPE TEST CERTIFICATES:**

The Bidder shall furnish the type test certificates of the for the tests as mentioned above as per the corresponding standards. All the tests shall be conducted at **CPRI/ERDA** as per the relevant IS/IEC. For **High voltage Silicone rubber material used for Polymer housing** the test are conducted at **CIPET/CPRI** as per the relevant standards. TPCODL/ TPWODL/ TPNODL/ TPSODL. TATA-POWER reserves the right to allow any other NABL accredited/ Govt. lab report under exceptional circumstances after due diligence/ scrutiny by DISCOM. Type tests should have been conducted during the period not exceeding 5 years from the date of opening the bid. In the event of any discrepancy in the test reports, i.e. any test report not acceptable, same shall be carried out without any cost implication to TPCODL/ TPNODL/ TPWODL/ TPSODL.

**9. PRE DISPATCH INSPECTION:**

The material shall be subject to inspection by a duly authorized representative of the TPCODL/TPNODL/TPWODL/TPSODL. Inspection may be made at any stage of manufacture at the discretion of the purchaser and the equipment, if found unsatisfactory as



to workmanship or material, the same is liable to rejection. Bidder shall grant free access to the places of manufacture to TPCODL/TPNODL/TPWODL/TPSODL's representatives at all times when the work is in progress. Inspection by the TPCODL/TPNODL/TPWODL/TPSODL or its authorized representatives shall not relieve the bidder of his obligation of furnishing equipment in accordance with the specifications. Material shall be dispatched after specific MDCC (Material Dispatch Clearance Certificate) is issued by TPCODL/TPNODL/TPWODL/TPSODL.

Following documents shall be sent along with material.

- a) Test reports
- b) MDCC issued by TPCODL/TPNODL/TPWODL/TPSODL
- c) Invoice in duplicate
- d) Packing list
- e) Drawings & catalogue
- f) Guarantee / Warrantee card
- g) Delivery Challan
- h) Other Documents (as applicable).

#### **10. INSPECTION AFTER RECEIPT AT STORES:**

The material received at TPCODL/TPNODL/TPWODL/TPSODL, Odisha store will be inspected for acceptance and shall be liable for rejection, if found different from the reports of the pre-dispatch inspection and one copy of the report shall be sent to Engineering department.

#### **11. GUARANTEE:**

Bidder shall stand guarantee towards design, materials, workmanship & quality of process/ manufacturing of items under the contract for due and intended performance of the same, as an integrated product delivered under this contract. In the event any defect is found by the Company up to a period of 18 months from the date of commissioning or 24 months from the date of last supplies made under the contract, whichever is earlier, supplier shall be liable to undertake to replace/rectify such defects at his own costs. within mutually agreed timeframe, and to the entire satisfaction of the Company, failing which the Company will be at liberty to get it replaced/rectified at supplier's risks and costs and recover all such expenses plus the Company's own charges (@ 20% of expenses incurred), from the supplier or from the "Security cum Performance Deposit" as the case may be.

The bidder shall further be responsible for 'free replacement' for another period of THREE

years from the end of guarantee period for any 'latent defects' if noticed by the company.

**12. PACKING:**

Supplier shall ensure that all the equipment covered under this specification shall be prepared for rail/road transport and be packed in such a manner so as to protect the equipment from damage in transit. The material used for packing shall be environmentally friendly. All insulators shall be packed in strong corrugated box of min. 7 ply duly palette or wooden crates. The gross weight of the crates along with the material shall not normally exceed 100 Kg to avoid handling problem. The crates shall be suitable for outdoor storage under wet climate during rainy season. Each wooden case / crate / corrugated box shall have all the markings stencilled on it in indelible ink. The bidder shall provide instructions regarding handling and storage precautions to be taken at site.

**13. TENDER SAMPLE:**

Bidder shall submit the sample of material during submission of Bids.

**14. QUALITY CONTROL:**

The bidder shall submit with the offer Quality Assurance Plan indicating the various stages of inspection, the tests and checks which will be carried out on the material of construction, components during manufacture and bought out items and fully assembled component and equipment after finishing. As part of the plan, a schedule for stage and final inspection within the parameters of the delivery schedule shall be furnished. The Purchaser's engineer or its nominated representative shall have free access to the manufacturer's/sub-supplier's works to carry out inspections. The bidder shall ensure that the material supplied is as per the Guaranteed Technical Particulars as specified in the specifications.

**15. TESTING FACILITIES:**

Bidder shall have adequate in-house testing facilities for carrying out all routine tests & acceptance tests as per relevant International / Indian standards.

**16. MANUFACTURING ACTIVITIES:**

The successful bidder will have to submit the bar chart for various manufacturing activities clearly elaborating each stage, with quantity. This bar chart should be in line with the Quality assurance plan submitted with the offer.

**17. SPARES, ACCESSORIES AND TOOLS**

Not applicable.





### 18. DRAWINGS AND DOCUMENTS

Following drawings and documents shall be submitted in line with the requirement of Tender specifications:

- a) Completely filled in Schedule “A” Guaranteed Technical Particulars & Schedule “B” Deviations
- b) Work Experience details
- c) Type test certificates.
- d) Drawing 1 set of Hard Copy & Soft copy PDF File containing complete information about manufacturing.

### 19. SCHEDULE- “A” GUARANTEED TECHNICAL PARTICULARS

SL. NO.	TECHNICAL PARTICULARS	TO BE FURNISHED BY BIDDER
1	Type of insulator	
2	Reference Standard	
3	Material of FRP Rod	
4	Material of sheds	
5	Material of End Fittings	
6	Material of sealing compound	
7	Colour of sheds	
8	Rated system voltage	
9	Highest system voltage	
10	Dry Power Frequency Withstand voltage	
11	Wet Power Frequency Withstand voltage	
12	Dry Lightning Impulse withstand voltage	
13	Dry Lightning Impulse Flashover voltage	
14	RIV at 1 MHz when energized at 10 KV / 30 KV (rms) under dry condition	
15	Creepage distance (min)	
16	Min Failing load/ SCL (Specified cantilever Load)	
17	Dia of FRP Rod	
18	Length of FRP Rod (min)	
19	Dia of weather sheds	
20	Thickness of housing	
21	Dry arc distance(min)	
22	Method of fixing sheds to housing	
23	Visible Discharge Voltage	
24	Type of sheds	

 	 	<b>Specification No:</b> <a href="#">ENG-HV-2027</a>  <b>Specification Name:</b> Technical Specification For 11kV Polymeric Pin Insulator (5KN)
--	--	--

SL. NO.	TECHNICAL PARTICULARS	TO BE FURNISHED BY BIDDER
25	Dia of bottom end fitting	
26	Thread length of bottom end fitting	

**20. SCHEDULE “B” DEVIATIONS:**

**(TO BE ENCLOSED WITH TECHNICAL BID)**

All deviations from this specification shall be set out by the Bidders, clause by Clause in this schedule. Unless specifically mentioned in this Schedule, the tender shall be deemed to confirm the purchaser's specifications:

SL. No	Clause No.	Details of deviation with justifications

We confirm that there are no deviations apart from those detailed above.

Seal of the Company:

Signature

Designation

**CONTENTS**

1. SCOPE
2. APPLICABLE STANDARDS
3. CLIMATIC CONDITIONS OF THE INSTALLATION
4. GENERAL TECHNICAL REQUIREMENTS
5. GENERAL CONSTRUCTIONS
6. MARKING
7. TESTS
8. TYPE TEST CERTIFICATES
9. PRE-DISPATCH INSPECTION
10. INSPECTION AFTER RECEIPT AT STORES
11. GUARANTEE
12. PACKING
13. TENDER SAMPLE
14. QUALITY CONTROL
15. TESTING FACILITIES
16. MANUFACTURING ACTIVITIES
17. SPARES, ACCESSORIES AND TOOLS
18. DRAWINGS AND DOCUMENTS
19. SCHEDULE "A" GUARANTEED TECHNICAL PARTICULARS
20. SCHEDULE "B" DEVIATIONS

## 1. SCOPE

This specification covers the technical requirements of design, manufacture, performance, testing at manufacturer's works, packing & forwarding, supply and unloading at store/ site, performance of 11 kV Ball and Socket Disc Polymer Insulator complete with all the accessories for trouble free and efficient performance.

## 2. APPLICABLE STANDARDS

The equipment covered by this specification shall unless otherwise stated, be designed, manufactured and tested in accordance with the latest editions of the following Indian, International Standards and shall conform to the regulations of the local authorities:

Ref. IS/IEC	Description
IEC:61109	Definition, test methods and acceptance criteria for composite insulators for A.C. overhead lines above 1000V.
IS:2071/ IEC:60060-1	Methods of High Voltage Testing.
IS:2486/ IEC:60120/ IEC:60372	Specification for Insulator fittings for Overhead Power Lines with a nominal voltage greater than 1000V.  Ball and socket couplings of string insulator units –Dimensions  Locking devices for ball and socket couplings of string insulator units - Dimensions and tests
IEC:60575	Thermal-mechanical performance test and mechanical performance test on string insulator units.
IS: 13134/ IEC: 60815	Guide for the selection of insulators in respect of polluted condition.
IEC: 60433	Insulators for overhead lines with a nominal voltage above 1000 V - Ceramic insulators for AC systems - Characteristics of insulator units of the long rod type.
STRI guide 1.92/1	Hydrophobicity Classification Guide.
IS:8263/ IEC:60437	Methods of RI Test of HV Insulators.
IS:4759	Hot dip zinc coatings on structural steel & other allied products.
IS:2629	Recommended practice for Hot Dip galvanization for iron and steel
IS:6745	Method for determination of mass of zinc coating on zinc coated iron and steel articles.
IS:3203	Methods of testing of local thickness of electroplated coatings.

Ref. IS/IEC	Description
IS:2633	Testing of Uniformity of coating of zinc coated articles.
ASTM D 578-05	Standard specification for glass fiber standards.
IS:4699	Refined secondary zinc

### 3. CLIMATIC CONDITIONS OF THE INSTALLATION:

SL.NO.	CONDITONS	VALUES
1	Max. altitude above sea level	1200m
2	Max. Ambient Temperature	50 °C
3	Max. Daily average ambient temp	35 °C
4	Min Ambient Temp	0 °C
5	Maximum temperature attainable by an object exposed to sun	60 °C
6	Maximum Humidity	95%
7	Minimum Humidity	10%
8	Average No. of thunderstorm days per annum	70
9	Average Annual Rainfall	150 cm
10	Average No. of rainy days per annum	120
11	Thermal Resistivity of soil	150 Deg. Ccm/W
12	Wind Pressure	126 kg/sq. m up to an elevation of 10 meter.
14	Earthquakes of intensity in horizontal direction	equivalent to seismic acceleration of 0.3g
15	Earthquakes of intensity in vertical direction	equivalent to seismic acceleration of 0.15g
16	Wind velocity	300 km/hr.

TPCODL/TPNODL/TPSODL/ TPWODL service area has heavy saline conditions along the coast and High cyclonic Intensity winds with speed up to 300 Km ph. The atmosphere is generally laden with mild acid, dust in suspension during the dry months, and is subjected to fog in cold months.

#### 4. GENERAL TECHNICAL REQUIREMENTS:

- i) The Composite insulators will be used on 11kV lines on which the conductor will be ACSR/AAAC of sizes 100 Sq.mm. The insulators should withstand the conductor tension, the reversible wind load as well as the high frequency vibrations due to wind. Insulator shall be suitable for moderately to heavily polluted, Humid & High saline atmosphere.
- ii) Bidder must be indigenous manufacturer and supplier of Composite insulator of rating 11kV or above or must have developed proven in house technology and manufacturing process for composite insulators of above rating or possess technical collaboration/association with the manufacturer of composite insulators of rating 11kV or above. The Bidder shall furnish necessary evidence in support of the above along with the bid which can be in the form of certification from Utilities concerned, or any other documents to the satisfaction of the Owner.
- iii) Insulators shall be suitable for Strain type of load and shall be of B&S type. The diameter of Composite Insulator shall be as per technical specification.
- iv) Insulators shall have sheds with good self-cleaning properties. Insulator shed profile, spacing, projection etc. and selection in respect of polluted conditions shall be generally in accordance with the commendation of IEC- 60815/ IS: 13134.
- v) The tolerances on all dimensions e.g. diameter, length and creepage distance shall be allowed as follows in line with-IEC 61109:

$$\pm (0.04d + 1.5) \text{ mm when } d \leq 300 \text{ mm}$$

$$\pm (0.025d+6) \text{ mm when } d > 300 \text{ mm}$$

Where, d being the dimensions in millimetres for diameter, length or creepage distance as the case may be. **However, no negative tolerance shall be applicable to creepage distance.**

- vi) The composite insulators including the end fitting connection shall be standard design suitable for use with the hardware fittings of any make conforming to relevant IEC/IS standards.
- vii) All surfaces shall be clean, smooth, without cuts, abrasions or projections. No part shall be subjected to excessive localized pressure. The insulator and metal parts shall be so designed and manufactured that it shall avoid local corona formation and not generate any radio interference beyond specified limit under the operating conditions.
- viii) The composite insulators offered shall be suitable for use of hotline maintenance technique so that usual hot line operation can be carried out with ease, speed and safety.



SL. No.	TECHNICAL PARTICULARS	DESIRED VALUE
		Min. requirement for 11 kV 70 KN
1	Type of Insulator	Polymeric B&S
2	Standard according to which the insulators manufactured and tested.	IEC 61109
3	Name of material used in manufacture of the insulator with class/grade)	High voltage grade Silicone rubber Wacker-Germany, Dow Corning-USA
(a)	Material of core (FRP rod) (I) E-glass of ECR-glass.	ECR or BORRON FREE
(b)	Material of housing weather sheds (silicon content)	Silicon content of minimum 40% by weight
(c)	Material of end fittings	SGI/MCI/Forged Steel
(d)	Sealing compound for end fittings	RTV SILICON
4	Colour	GREY
5	Electrical characteristics	
(a)	Nominal system voltage	11 kV
(b)	Highest system voltage	12 kV
(c)	Dry Power frequency withstand voltage	70 kV
(d)	Wet Power frequency withstand voltage	35 kV
(e)	Dry flashover voltage	75 kV
(f)	Wet flash over voltage	40 kV
(g)	Dry lighting impulse withstand voltage	
	(a) Positive	75 kVp
	(b) Negative	75 kVp
(h)	Dry lighting impulse flashover voltage	
	a) Positive	80kVp
	b) Negative	80kVp
(i)	FRP rod leakage current at 175 V/mm	< 0.05 mA
(j)	RIV at 1 MHz when energized at 10 kV/30kV (rms) under dry condition.	< 50 microvolt
(k)	Creepage distance (Min.)	320 MM
6	Minimum failing load.	70 KN
7	<b>Dimensions of insulator</b>	
(i)	Weight (Approx.)	1.2 kg
(ii)	Dia of FRP rod	16 mm
(iii)	Length of FRP rod	240 mm
(iv)	Dia of weather sheds	≥90 mm
(v)	Thickness of housing	3 mm
(vi)	Dry arc distance Dimensioned drawings of insulator (including weight with tolerances in weight)	175 mm

SL. No.	TECHNICAL PARTICULARS	DESIRED VALUE
		Min. requirement for 11 kV 70 KN
8	Method of fixing of sheds to housing (specify). Single mould or Modular construction (injection moulding/compression)	Injection Moulding
9	Type of sheds	Aerodynamic

**5. GENERAL CONSTRUCTIONS:**

Composite Insulators shall be designed to meet the light quality, safety and reliability and are capable of withstanding a wide range of environmental conditions. Polymeric Insulators shall consist of THREE parts, at least two of which are insulating parts:

- (a) Core- the internal insulating part
- (b) Housing- the external insulating part
- (c) Metal end fittings.

**5.1 CORE**

It shall be a glass-fiber reinforced epoxy resin rod of high strength (FRP rod). Glass fibers and resin shall be optimized in the FRP rod. Glass fibers shall be Boron free electrically corrosion resistant (ECR) glass fiber and shall exhibit both high electrical integrity and high resistance to acid corrosion. The matrix of the FRP rod shall be Hydrolysis resistant. The FRP rod shall be manufactured through Pultrusion process. The FRP rod shall be void free. Electrically Corrosion Resistant (ECR) grade fiber glass reinforced plastic (FRP) rod having at least 80% fibres by weight.

**5.2 POLYMER HOUSING:**

The FRP rod shall be covered by a seamless sheath of high voltage grade Silicone rubber housing of thickness 3mm minimum. It shall be one- piece housing using only Injection Moulding process to cover the core. The housing shall be designed to provide the necessary creepage distance and protection against environmental influences, external pollution and humidity. Housing shall conform to the requirements of IEC 60815 with latest amendments. All surfaces shall be clean, smooth, without cuts, abrasions or projections. No part shall be subjected to excessive localized pressure. The insulator and metal parts shall be so designed and manufactured that it shall avoid local corona formation and not generate any radio interference beyond specified limit under the operating condition. It shall be extruded or directly moulded on core and shall have chemical bonding with the FRP rod. The strength of the bond shall be greater than the tearing strength of the polymer.

Sheath material in the bulk as well as in the sealing / bonding area shall be free from voids.

### 5.3 WEATHERSHEDS

The composite polymer weathersheds made of high voltage grade Silicone rubber polymer shall be moulded as part of the sheath and shall be free from imperfections. It should protect the FRP rod against environmental influences, external pollution and humidity. The weathersheds should have **silicon content of minimum 40% by weight**. The strength of the weather shed to sheath interface shall be greater than the tearing strength of the polymer. The interface, if any, between sheds and sheath (housing) shall be free from voids. Housing and weathersheds material shall have tensile strength of 3 Mpa with 400% elongation minimum and tear strength of 16 N/mm.

### 5.4 HARDWARE FITTINGS:

- a) End fitting transmit the mechanical load to the core. They shall be made of spheroidal graphite cast iron, malleable cast iron or forged steel or aluminium alloy. Metal end fitting shall be suitable for Ball and socket type hardware of respective specified mechanical load and shall be hot dip galvanized in accordance with IS 2629.
- b) They shall be connected to the rod by means of a controlled compression technique. The material used in fittings shall be corrosion resistant. As the main duty of the end fittings is the transfer of mechanical loads to the core the fittings should be properly attached to the core by a coaxial or hexagonal compression process & should not damage the individual fibers or crack the core.
- c) The gap between fittings and sheath shall be sealed by flexible silicone elastomeric compound or silicone alloy compound sealant, system of attached of end fitting to the rod shall provide superior sealing performance between housing, i.e. seamless sheath and metal connection. The sealing must be moisture proof.
- d) The dimensions of end fittings of insulators shall be in accordance with the standard dimensions stated in IEC: 60120/IS: 2486 - Part-II.
- e) Outer portion of ball or socket should be Zinc sleeved with minimum 99.95% purity of Electrolytic high grade zinc.
- f) **Ball pin and socket couplings:** Ball pin and socket shall be of forged steel and dimensions are as specified in IS 2486 (Part-2). Insulator metal caps shall be made of malleable cast iron conforming to IS 14329.
- g) **Locking device of the coupling:** The security clips to be used as a locking device for ball and socket coupling shall be 'R' shaped hump type or 'W' type as per IS 2486. The locking device shall be resilient, corrosion resistant, and of suitable mechanical strength. Material to be used for 'W' locking clip is phosphor bronze and for 'R' type locking clip is stainless

steel. The hardness and temper of material are important for their satisfactory operation. The locking devices shall retain their ability after being operated from the locking to the coupling position at least twenty times at normal temperature. They should be effective at the lowest temperature likely to be encountered in service. Socket for use with W-clips have the lower edge of the rectangular slot at the level of bottom of the socket. The slot is so shaped that it will accept the W-clip and retain it in two distinct positions when operated for coupling and locking. The shape of the W-clip is such that complete withdrawal when moving from the locking to the coupling position prevented.

- h) All ferrous parts shall be hot dip galvanized to give a minimum average coating of zinc equivalent to 705 gm/Sq.m, or 100mm min. thickness and shall be in accordance with the requirement of IS: 4759, The zinc used for galvanizing shall be of purity 99.5% as per IS: 4699. The zinc coating shall be uniform, adherent, smooth, reasonably bright continuous and free from imperfections such as flux, ash rust stains, bulky white deposits and blisters. Before ball fittings and galvanized, all die flashing on the shank and on the bearing surface of the ball shall be carefully removed without reducing the design dimensional requirements.

## 6. MARKING:

Each insulator shall be legibly and indelibly marked (embossing/engraved) to show the following:

- a) Name & Trade mark of the manufacturer
- b) Voltage Grade
- c) Year of manufacturing
- d) Minimum failing load in KN
- e) "TPCODL/TPNODL/TPWODL/TPSODL" Name should be mentioned on each insulator

## 7. TESTS

The bidder shall be required to submit complete set of the following test reports along with the offer: -

### 7.1 ACCEPTANCE TESTS

- i) Verification of dimensions
- ii) End Sealing test (FRP rod and Silicone rubber housing)
- iii) Visual examination (Free from voids, cavity, foreign particle and scratch/nick spot)
- iv) Mechanical performance Test
- v) Galvanizing Test

- vi) Mechanical Failing Load Test
- vii) Dry Power Frequency Withstand Voltage Test
- viii) Wet Power Frequency Withstand Voltage Test
- ix) Verification of the locking system or the tightness of the interface between end fitting and insulator housing

## 7.2 ROUTINE TESTS

- i) Visual examination (Free from voids, cavity, foreign particle and scratch/nick spot)
- ii) Mechanical Load test
- iii) Electrical routine test

## 7.3 TYPE TESTS

### A) For Insulators

- i) Dry Power Frequency Withstand Voltage Test
- ii) Dry Power Frequency Voltage Flashover Test
- iii) Dry lightning impulse withstand voltage test.
- iv) Wet Power Frequency Withstand Voltage Test
- v) Wet Power Frequency Voltage Flashover Test
- vi) Mechanical failing load test.
- vii) Salt fog test: On insulators for 1000 hr as per IEC
- viii) Galvanization test
- ix) Damaged Limit Proof Test
- x) Radio interference test.

### B) For Silicon rubber

- i) Tensile Strength
- ii) Elongation
- iii) Tear Strength
- iv) Inclined plane Tracking & Erosion resistance test
- v) Volume Resistivity
- vi) Dielectric constant
- vii) Dielectric Strength
- viii) Density
- ix) Hardness
- x) Arc Resistance
- xi) Silicone Content
- xii) Flammability

- xiii) Limiting oxygen index test
- xiv) Resistance to weathering & UV.
- xv) Specific gravity

**C) For FRP rods**

- i) Verification of dimensions
- ii) Specific Gravity
- iii) Glass Content
- iv) Water Diffusion Test
- v) Hardness
- vi) Dye Penetration Test
- vii) Flexural Strength
- viii) Brittle fracture resistance test.
- ix) Water Diffusion Test

**D) For End Fittings**

- i) Thickness of Zinc coating
- ii) Uniformity of Zinc Coating

**8. TYPE TEST CERTIFICATES:**

The Bidder shall furnish the type test certificates of the for the tests as mentioned above as per the corresponding standards. All the tests shall be conducted at **CPRI/ERDA/Other Govt. Lab** as per the relevant IS/IEC. For **High voltage Silicone rubber material used for Polymer housing** the test are conducted at **CIPET/CPRI** as per the relevant standards. TPCODL/TPWODL/TPNODL/TPSODL. TATA-POWER reserves the right to allow any other NABL accredited/ Govt. lab report under exceptional circumstances after due diligence/ scrutiny by DISCOM. Type tests should have been conducted in certified Test laboratories during the period not exceeding 5 years from the date of opening the bid. In the event of any discrepancy in the test reports, i.e. any test report not acceptable, same shall be carried out without any cost implication to TPCODL/TPNODL/TPWODL/TPSODL.

**9. PRE DISPATCH INSPECTION:**

The material shall be subject to inspection by a duly authorized representative of the TPCODL/TPNODL/TPWODL/TPSODL. Inspection may be made at any stage of manufacture at the discretion of the purchaser and the equipment, if found unsatisfactory as to workmanship or material, the same is liable to rejection. Bidder shall grant free access to the places of manufacture to TPCODL/TPNODL/TPWODL/TPSODL's representatives at all

times when the work is in progress. Inspection by the TPCODL/TPNODL/TPWODL/TPSODL or its authorized representatives shall not relieve the bidder of his obligation of furnishing equipment in accordance with the specifications. Material shall be dispatched after specific MDCC (Material Dispatch Clearance Certificate) is issued by TPCODL/ TPNODL/ TPWODL/ TPSODL.

Following documents shall be sent along with material.

- a) Test reports
- b) MDCC issued by TPCODL/TPNODL/TPWODL/TPSODL
- c) Invoice in duplicate
- d) Packing list
- e) Drawings & catalogue
- f) Guarantee / Warrantee card
- g) Delivery Challan
- h) Other Documents (as applicable).

**10. INSPECTION AFTER RECEIPT AT STORES:**

The material received at TPCODL/TPNODL/TPWODL/TPSODL, Odisha store will be inspected for acceptance and shall be liable for rejection, if found different from the reports of the pre-dispatch inspection and one copy of the report shall be sent to Engineering department.

**11. GUARANTEE:**

Bidder shall stand guarantee towards design, materials, workmanship & quality of process/ manufacturing of items under the contract for due and intended performance of the same, as an integrated product delivered under this contract. In the event any defect is found by the Company up to a period of 18 months from the date of commissioning or 24 months from the date of last supplies made under the contract, whichever is earlier, supplier shall be liable to undertake to replace/rectify such defects at his own costs. within mutually agreed timeframe, and to the entire satisfaction of the Company, failing which the Company will be at liberty to get it replaced/rectified at supplier's risks and costs and recover all such expenses plus the Company's own charges (@ 20% of expenses incurred), from the supplier or from the "Security cum Performance Deposit" as the case may be.

The bidder shall further be responsible for 'free replacement' for another period of THREE years from the end of guarantee period for any 'latent defects' if noticed by the company.

**12. PACKING:**

Supplier shall ensure that all the equipment covered under this specification shall be prepared



for rail/road transport and be packed in such a manner so as to protect the equipment from damage in transit. The material used for packing shall be environmentally friendly. All insulators shall be packed in strong corrugated box of min. 7 ply duly palette or wooden crates. The gross weight of the crates along with the material shall not normally exceed 100 Kg to avoid handling problem. The crates shall be suitable for outdoor storage under wet climate during rainy season. Each wooden case / crate / corrugated box shall have all the markings stencilled on it in indelible ink. The bidder shall provide instructions regarding handling and storage precautions to be taken at site.

**13. TENDER SAMPLE:**

Bidder shall submit the sample of material during submission of Bids.

**14. QUALITY CONTROL:**

The bidder shall submit with the offer Quality Assurance Plan indicating the various stages of inspection, the tests and checks which will be carried out on the material of construction, components during manufacture and bought out items and fully assembled component and equipment after finishing. As part of the plan, a schedule for stage and final inspection within the parameters of the delivery schedule shall be furnished. The Purchaser's engineer or its nominated representative shall have free access to the manufacturer's/sub-supplier's works to carry out inspections. The bidder shall ensure that the material supplied is as per the Guaranteed Technical Particulars as specified in the specifications.

**15. TESTING FACILITIES:**

Bidder shall have adequate in-house testing facilities for carrying out all routine tests & acceptance tests as per relevant International / Indian standards.

**16. MANUFACTURING ACTIVITIES:**

The bidder shall get the approved drawing and GTP before start of manufacturing activity. The successful bidder will have to submit details of the offered design & components for approval as per specification. CAT-A/CAT-B is mandatory to start manufacturing.

**17. SPARES, ACCESSORIES AND TOOLS**

Not applicable.

**18. DRAWINGS AND DOCUMENTS**

Following drawings and documents shall be submitted in line with the requirement of Tender specifications:

- a) Completely filled–in clause wise compliance of the specification



- b) Schedule "B" Deviations
- c) Work Experience details
- d) Type test certificates.
- e) Drawing 1 set of Hard Copy & Soft copy PDF File containing complete information about manufacturing.

**19. SCHEDULE- "A" GUARANTEED TECHNICAL PARTICULARS**

Bidder to submit completely clause wise compliance of this specification

**20. SCHEDULE "B" DEVIATIONS:**

**(TO BE ENCLOSED WITH TECHNICAL BID)**

All deviations from this specification shall be set out by the Bidders, clause by Clause in this schedule. Unless specifically mentioned in this Schedule, the tender shall be deemed to confirm the purchaser's specifications:

SL. No	Clause No.	Details of deviation with justifications

We confirm that there are no deviations apart from those detailed above.

Seal of the Company:

Signature

Designation



**Document No:** ENG-HV-2036

**Document Title:** Specification GI Coil Earthing

**CONTENTS**

1. SCOPE
2. APPLICABLE STANDARDS
3. CLIMATIC CONDITIONS OF THE INSTALLATION
4. GENERAL CONSTRUCTIONS
5. GENERAL TECHNICAL REQUIREMENTS
6. MARKING
7. TESTS
8. TYPE TEST CERTIFICATES
9. PRE-DESPATCH INSPECTION
10. INSPECTION AFTER RECEIPT AT STORES
11. GUARANTEE
12. PACKING
13. TENDER SAMPLE
14. QUALITY CONTROL
15. MINIMUM TESTING FACILITIES
16. MANUFACTURING ACTIVITIES
17. SPARES, ACCESSORIES AND TOOLS
18. DRAWINGS
19. SCHEDULE OF DEVIATIONS

Initiator		HOG ( Plant Engineering)	
-----------	--	--------------------------	--



**Document No:** ENG-HV-2036

**Document Title:** Specification GI Coil Earthing

### 1.0 SCOPE

The scope of this document is to give design & constructional features, inspection, supply and transportation guidelines for GI Coil Earthing for TPCODL/TPNODL/TPWODL/TPSODL.

### 2.0 APPLICABLE STANDARDS

The equipment covered by this specification shall unless otherwise stated, be designed, manufactured and tested in accordance with latest editions of the following standards/IEC and shall conform to the regulations of local statutory authorities.

- a) IS: 280 - Mild steel wire for general engineering purposes.
- b) IS: 4826 - Specification for hot-dipped galvanized coatings on round steel wires.
- c) IS: 7887 - Mild steel wire rods for general engineering purposes.
- d) IS: 2629 - Recommended practice for hot-dip galvanizing of iron and steel
- e) IS: 1521 - Method for tensile testing for steel wires
- f) IS: 1755 - Method for wrapping testing for wire
- g) IS: 6745 - Methods for determination of mass of zinc coating on zinc coated iron and steel

### 3.0 CLIMATIC CONDITIONS:

1	Maximum ambient temperature	50 deg C
2	Max. Daily average ambient temp	35 deg C
3	Min Ambient Temperature	0 deg C
4	Maximum Humidity	95%
5	Average Annual Rainfall	1500 mm
6	Average No. of rainy days per annum	120
7	Altitude above MSL not exceeding	1000m
8	Wind Speed	300 Km/hr
9	Earthquakes of an intensity in horizontal direction	equivalent to seismic acceleration of 0.3g
10	Earthquakes of an intensity in vertical direction	equivalent to seismic acceleration of 0.15g (g being acceleration due to gravity)

TPCODL/TPNODL/TPSODL/TPWODL service area has heavy saline conditions along the coast and High cyclonic Intensity winds with speed upto 300 Kmph. The atmosphere is generally laden with mild acid and dust in suspension during the dry months and is subjected to fog in cold months.

**4.0 GENERAL CONSTRUCTION:**

**The material shall be-**

- a) Heavy class as per IS- 1239/IS 1161-1979.
- b) Galvanizing to be done after fabrication as per IS: 4826
- c) The design shall be suitable for the climatic condition stated above.
- d) Tolerance in Dimensions & Weight should be  $\pm 2.5\%$  unless otherwise specified
- e) Dimensional tolerance shall be as per IS 1852-1985
- f) Zinc electroplated/painted material will not be accepted, should be properly galvanized.
- g) No Rusting is acceptable.

**5.0 GENERAL TECHNICAL REQUIREMENTS:**

Sr. No.	DESCRIPTION	REQUIREMENT
1	Material of earthing coil	GI wire
2	Confirming Standard	IS 280, IS 7887, IS 4826
3	Nominal diameter of Wire	4.00mm with tolerance $\pm 2.5\%$
4	No. of Turns	115 Nos. (Min)
5	External dia of Coil	50mm (Min)
6	Length of Coil	460mm / 450mm (Min)
7	Free Length of G.I wire of earthing coil	2500mm
8	Mass of Zinc Coating	280gm/Sq.mm (Before Coiling) & 266gm/Sq. mm (After Coiling)
9	Total Weight of Coil	1.850 Kgs. (Min)
10	Tolerance in Dimensions & Weight	$\pm 2.5\%$

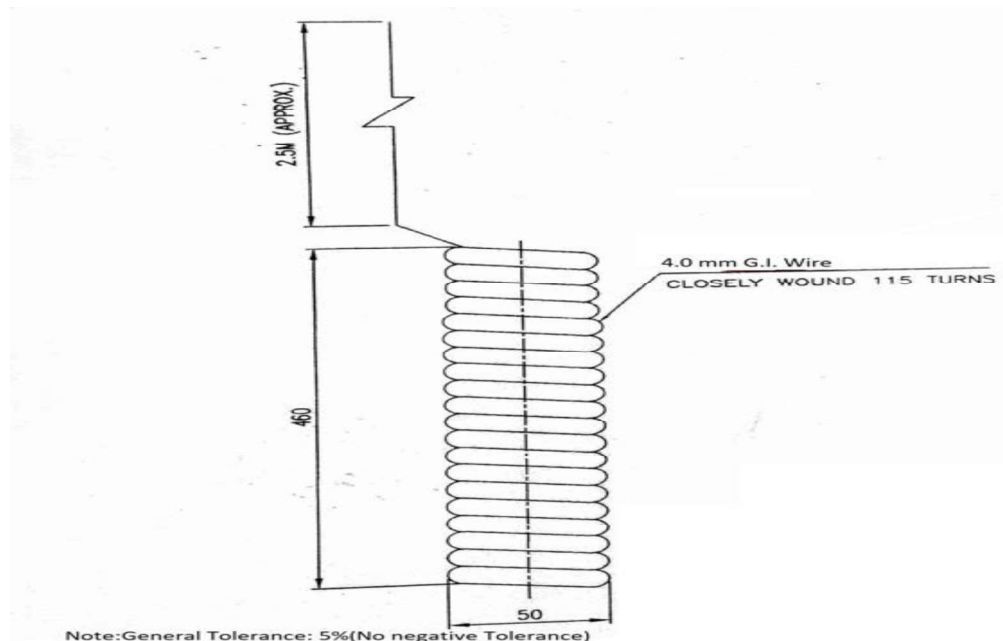



**Document No:** ENG-HV-2036

**Document Title:** Specification GI Coil Earthing

#### 6.0 MARKING:

The unit shall be appropriately marked as **"PROPERTY OF TPCODL/TPNODL/TPWODL/TPSODL"** and with the name of the vendor and year of manufacturing at suitable location.

#### 7.0 TESTS

All routine, acceptance & type tests shall be carried out in accordance with the relevant IS/IEC. All routine/acceptance tests shall be witnessed by the purchaser/his authorized representative. All components shall also be type tested as per the relevant standards.

Tests	IS to be referred
Visual test	As a routine test
Dimensional tests	As per the drawing
Tensile test	IS 280
Wrapping test	IS 280
Hot dip galvanizing	IS 4826
Determination of mass of zinc coating on zinc coated iron and steel	IS 4826

#### 8.0 TYPE TEST CERTIFICATE

The bidder shall furnish the type test certificates of the Specification for GI Coil Earthing for the tests as mentioned above as per the corresponding standards. All the tests shall be conducted at CPRI/ERDA/NABL accredited as per the relevant standards. Type test should have been conducted during the period not exceeding 5 years from the date of opening the bid. In the event of any discrepancy in the test reports i.e. any test report not acceptable or any/all type tests (including additional type tests, if any) not carried out, same shall be carried out without any cost implication to TPCODL/TPNODL/TPWODL/TPSODL.

#### 9.0 PRE DISPATCH INSPECTION

Equipment shall be subjected to inspection by a duly authorized representative of TPCODL/TPNODL/TPWODL/TPSODL. Inspection may be made at any stage of manufacture at the discretion of the purchaser and the equipment, if found unsatisfactory as to workmanship or material, the same is liable to rejection. Bidder shall grant free access to the places of manufacture to TPCODL/TPNODL/TPWODL/TPSODL's representatives at all times when the work is in progress. Inspection by TPCODL/TPNODL/TPWODL/TPSODL or its authorized representatives shall not relieve the bidder of his obligation of furnishing equipment in accordance with the specifications. Material shall be dispatched after specific MDCC (Material Dispatch Clearance Certificate) is issued by TPCODL/TPNODL/TPWODL/TPSODL. Following documents shall be sent along with material.

- a) Test reports
- b) MDCC issued by TPCODL/TPNODL/TPWODL/TPSODL
- c) Invoice in duplicate
- d) Packing list
- e) Drawings & catalogue
- f) Guarantee / Warrantee card
- g) Delivery Challan
- h) Other Documents (as applicable)

#### 10.0 INSPECTION AFTER RECEIPT AT STORES



**Document No:** ENG-HV-2036

**Document Title:** Specification GI Coil Earthing

The material received at TPCODL/TPNODL/TPWODL/TPSODL, Berhampur, Odisha store will be inspected for acceptance and shall be liable for rejection, if found different from the reports of the pre-dispatch inspection and one copy of the report shall be sent to Project Engineering department.

#### **11.0 GUARANTEE**

Bidder shall stand guarantee towards design, materials, workmanship & quality of process / manufacturing of items under this contract for due and intended performance of the same, as an integrated product delivered under this contract. In the event any defect is found by the Company up to a period of at least 12 months from the date of commissioning or 24 months from the date of last supplies made under the contract whichever is later. In the event any defect is found by the Company up to a period of 12 months from the date of commissioning or 24 months from the date of last supplies made under the contract, whichever is earlier, supplier shall be liable to undertake to replace/rectify such defects at his own costs.

#### **12.0 PACKING**

Bidder shall ensure that all the equipment covered under this specification shall be prepared for rail/road transport in a manner so as to protect the equipment from damage in transit.

#### **13.0 TENDER SAMPLE**

Not Applicable.

#### **14.0 QUALITY CONTROL**

The bidder shall submit with the offer Quality assurance plan indicating the various stages of inspection, the tests and checks which will be carried out on the material of construction, components during manufacture and bought out items and fully assembled component and equipment after finishing. As part of the plan, a schedule for stage and final inspection within the parameters of the delivery schedule shall be furnished. TPCODL/TPNODL/TPWODL/TPSODL's engineer or its nominated representative shall have free access to the manufacturer's/sub-supplier's works to carry out inspections.

#### **15.0 MINIMUM TESTING FACILITIES**

Bidder shall have adequate in house testing facilities for carrying out all routine tests & acceptance tests as per relevant International / Indian standards

#### **16.0 MANUFACTURING ACTIVITIES**

The successful bidder will have to submit the bar chart for various manufacturing activities clearly elaborating each stage, with quantity. This bar chart should be in line with the Quality assurance plan submitted with the offer. This bar chart will have to be submitted within 15 days from the release of the order.

#### **17.0 SPARES, ACCESSORIES AND TOOLS**

NA

#### **18.0 DRAWINGS**

Following drawings & documents shall be prepared based on Purchaser's specifications and statutory requirements with complete BOM and shall be submitted with the bid:

- a) Completely filled-in Technical Parameters (refer Cl. 5)
- b) General description of the equipment and all components including brochures
- c) General arrangement drawings
- d) Type Test Certificates.
- e) Experience List
- f) Manufacturing schedule and test schedule after the contract, four (4) copies of the drawings, drawn to scale, describing the equipment in detail shall be forwarded for approval and shall subsequently provide four (4) complete sets of final drawings, one of which shall be auto positive suitable for reproduction, before the dispatch of the equipment. Soft copy (Compact Disk CD) of all the drawing, GTP, test certificates shall be submitted after the final approval of the same to the purchaser.



**Document No:** ENG-HV-2036

**Document Title:** Specification GI Coil Earthing

Following Drawings/Documents shall be submitted after the award of the contract:  
Drawings/documents to be submitted after the award of the contract:

S.No	Description	For Approval	For Review Information	Final Submission
1	Technical Parameters	√		√
2	General Arrangement drawings	√		√
3	Bill Of Material	√		√
4	Instruction for Use		√	√
5	QA & QC Plan	√	√	√
6	Routine, Acceptance & Type Test Certificates	√	√	√

All the documents & drawings shall be in English language.

## 19.0 SCHEDULE OF DEVIATIONS

### SCHEDULE OF DEVIATIONS

#### (TO BE ENCLOSED WITH TECHNICAL BID)

All deviations from this specification shall be set out by the Bidders, clause by Clause in this schedule. Unless specifically mentioned in this Schedule, the tender shall be deemed to confirm the purchaser's specifications:

S.No	Clause No.	Details of deviation with justifications

We confirm that there are no deviations apart from those detailed above.

Seal of the Company:

Signature  
Designation



**Specification No:** [ENG-LV-3002](#)

**Specification Name:**  
Specification for LT AB cable - 3  
Cores/ insulated messenger/ street  
light

## CONTENTS

1. SCOPE
2. APPLICABLE STANDARDS
3. CLIMATIC CONDITIONS OF THE INSTALLATION
4. GENERAL TECHNICAL REQUIREMENTS
5. GENERAL CONSTRUCTIONS
6. MARKING
7. TESTS
8. TYPE TEST CERTIFICATES
9. PRE-DISPATCH INSPECTION
10. INSPECTION AFTER RECEIPT AT STORES
11. GUARANTEE
12. PACKING
13. TENDER SAMPLE
14. QUALITY CONTROL
15. TESTING FACILITIES
16. MANUFACTURING FACILITIES
17. SPARES, ACCESSORIES AND TOOLS
18. DRAWINGS AND DOCUMENTS
19. SCHEDULE "A" GUARANTEED TECHNICAL PARTICULARS
20. SCHEDULE "B" DEVIATIONS



**1. SCOPE:**

This specification covers the technical requirements of design, manufacture, test at manufacturer's works, packing & forwarding, supply and unloading at store/site and performance of LT ABC cable for trouble free and efficient operation. The specific requirements are covered in the enclosed technical data sheet.

The sizes specified in the specifications are tabulated below:

SI.No	Phase Conductor (No. of Cores x Size in sqmm)	Insulated Messenger (No. of Cores x Size in sqmm)	Streetlight (No. of Cores x Size in sqmm)
1	3C x 95	1C x 70	1C x 16
2	3C x 70	1C x 50	1C x 16
3	3C x 50	1C x 35	1C x 16
4	3C x 35	1C x 25	1C x 16
5	1C x 35	1C x 25	—
6	3C x 50	1C x 35	—
7	3C x 35	1C x 25	—

**2. APPLICABLE STANDARDS:**

The equipment covered by this specification shall unless otherwise stated, be designed, manufactured and tested in accordance with the latest editions of the following Indian, International Standards and shall conform to the regulations of the local authorities:





IS-398 (Part IV)	Aluminum conductor for overhead transmission purposes- Part IV Aluminum alloy stranded conductor
IS-5216	Guide for safety procedures and practices in electric works
IS-7098 (part-I)	Specification for Cross-linked_ polyethylene insulated PVC sheathed cables- Part I for working voltage up to and including 1100 volts.
IS-8130	Specification for Conductor for insulated electric cables & flexible cords.
IS-10418	Specification for drums for electric cables
BS-5468	Cross-linked polyethylene insulation of electric cables
IEC-540	Test methods for insulations and sheaths of electric cables and cords
IEC-60228/3	Conductor for insulated cables
IEC-60502-1	Power cables with extruded insulation and their accessories for rated voltages from 1kV (Um=1.2kV), up-to 30kV(Um=36kV)-Part 1:Cables for rated voltages of 1 kV /Um=1,2kV) and 3kV/Um=3.6kV)
ASTM G-53/DIN 56687	UV testing of XLPE insulation
SANS 1713	South African Standard for Aerial Bunched conductor
IS14255	Aerial Bunched conductors for working voltages up to and including 1100 volts

**3. CLIMATIC CONDITIONS:**

SL.NO.	CONDITIONS	VALUES
1	Max. altitude above sea level	1200m
2	Max. Ambient Temperature	50 °C
3	Max. Daily average ambient temp	35 °C
4	Min Ambient Temp	0 °C
5	Maximum temperature attainable by an object exposed to sun	60 °C
6	Maximum Humidity	95%
7	Minimum Humidity	10%
8	Average No. of thunderstorm days per annum	70
9	Average Annual Rainfall	150 cm
10	Average No. of rainy days per annum	120
11	Thermal Resistivity of soil	150 Deg. Ccm/W
12	Wind Pressure	126 kg/sq. m up to an elevation of 10 meter.
14	Earthquakes of intensity in horizontal direction	equivalent to seismic acceleration of 0.3g
15	Earthquakes of intensity in vertical direction	equivalent to seismic acceleration of 0.15g
16	Wind velocity	300 km/hr.





Environmentally, some of the regions, where the work will take place include coastal areas, subject to high relative humidity, which can give rise to condensation. Onshore winds will frequently be salt laden. On occasions, the combination of salt and condensation may create pollution conditions for outdoor insulators. Some places are in heavily industrial polluted areas. Therefore, Outdoor material and equipment shall be designed and protected for use in exposed, heavily polluted, salty, corrosive and humid coastal atmosphere.

The atmosphere is generally laden with mild acid and dust in suspension during the dry months and is subjected to fog in cold months. The design of equipment and accessories shall be suitable to withstand seismic forces as mentioned above.





 	 	<b>Specification No:</b> <a href="#">ENG-LV-3002</a> <b>Specification Name:</b> Specification for LT AB cable 3 Cores insulated messenger street light
--	--	--

#### 4. GENERAL TECHNICAL REQUIREMENTS:

SL NO	DESCRIPTION	UNITS	3C×95 mm <sup>2</sup> (P)+1C×70mm <sup>2</sup> (M)+1CX16 mm <sup>2</sup> (StreetLight)	3C X 70 mm <sup>2</sup> (P)+ 1C X 50 mm <sup>2</sup> (M) +1C x 16 mm (Street Light)	3C×50 mm <sup>2</sup> (P)+1C×35mm <sup>2</sup> (M)+1CX 16mm <sup>2</sup> (Street Light)	3C X 35 mm <sup>2</sup> (P) + 1C X 25(M)+ 1C x 16 mm <sup>2</sup> (StreetLight)
1	Type of Cable		LT ABC cable with cross linked polyethylene insulated Phase and streetlighting core twisted around the insulated neutral cum messenger wire			
2	Size of Aerial Bunched cable		3C×95 mm <sup>2</sup> (P)+1C×70 mm <sup>2</sup> (M)+1CX 16 mm <sup>2</sup> (Street Light)	3C X 70 mm <sup>2</sup> (P)+ 1C X 50 mm <sup>2</sup> (M) +1C x 16 mm (Street Light)	3C×50 mm <sup>2</sup> (P)+1C×35 mm <sup>2</sup> (M)+1C X16 mm <sup>2</sup> (Street Light)	3C X 35 mm <sup>2</sup> (P) + 1C X 25 mm <sup>2</sup> (M)+ 1C x16 mm <sup>2</sup> (Street Light)
3	Rated Voltage	kv	1.1	1.1	1.1	1.1
4	System Voltage	kv	0.415- 0.433	0.415 - 0.433	0.415 - 0.433	0.415 - 0.433
5	Nominal Area of Phase Conductor	mm <sup>2</sup>	95	70	50	35
6	Nominal Area of Messenger	mm <sup>2</sup>	70	50	35	25
7	Phase Core		Stranded compacted circular aluminum conductor, Extruded XLPE insulated			
8	Neutral core & Messenger Wire		Stranded compacted circular aluminum alloy conductor, Extruded XLPE insulated			
9	Maximum conductor temperature during continuous operation	Deg C	90	90	90	90
10	Maximum conductor temperature during short circuit	Deg C	250	250	250	250
11	<b>Phase Core RYB insulated</b>					
a)	<b>Conductor</b>					
(i)	Material		EC Grade Aluminum of H4 Grade to IS: 8130:1984	EC Grade Aluminum of H4 Grade to IS: 8130:1984	EC Grade Aluminum of H4 Grade to IS: 8130:1984	EC Grade Aluminum of H4 Grade to IS: 8130:1984

 	 	<b>Specification No:</b> <a href="#">ENG-LV-3002</a>  <b>Specification Name:</b> Specification for LT AB cable 3 Cores insulated messenger street light
--	--	--

(ii)	No. of Cores & Nominal Size	mm <sup>2</sup>	3Cx95	3Cx70	3Cx50	3Cx35
(iii)	Minimum number of strand wires		15	12	6	6
(iv)	Diameter		Shall be suitably selected to meet conductor DC resistance as per IS 8130			
(v)	Max. DC Resistance of phase conductor at 20 deg.C	Ω/km	0.32	0.443	0.641	0.868
(vi)	Shape of Conductor		Stranded Compacted Circular			
(vii)	Short Circuit current rating of conductor for 1 sec	kA	8.93	6.58	4.7	3.29
(viii)	Continuous current rating in air at 40Deg. C	A	230	200	149	125
b)	<b>Insulation</b>					
i)	Material		XLPE Insulation as per IS 14255:1995			
ii)	Nominal Thickness	mm	1.5	1.5	1.5	1.2
iii)	Tolerance in Insulation Thickness	mm	XLPE Insulation as per IS 14255			
<b>12</b>	<b>Street light core</b>					
a)	<b>Conductor</b>					
i)	Material		EC grade aluminum of H4 grade to IS: 8130:1984			
ii)	Nominal size	mm <sup>2</sup>	16	16	16	16
iii)	Nominal no. of wire		7	7	7	7
iv)	Max DC resistance at 20 deg. C	Ohm/km	1.91(As per IS 8130:1984)	1.91(As per IS 8130:1984)		
v)	Shape of conductor		Stranded compacted circular			
b)	<b>Insulation</b>					
i)	Material		As per IS: 14255:1995			
ii)	Nominal thickness	mm	1.2	1.2	1.2	1.2
iii)	Tolerance in Insulation Thickness		XLPE Insulation as per IS 14255:1995			
<b>13</b>	<b>Neutral Cum Messenger Wire</b>					
a)	<b>Messenger wire</b>					
i)	Material		Aluminum Alloy Wire			
ii)	Nominal size	mm <sup>2</sup>	70	50	35	25

 	 	<b>Specification No:</b> <a href="#">ENG-LV-3002</a>  <b>Specification Name:</b> Specification for LT AB cable 3 Cores insulated messenger street light
--	--	--





iii)	No. and Nominal Dia. of each strand	No./m m	7/3.57	7/3.02	7/2.54	7/2.14
iv)	Calculated Maximum resistance at 20 deg C	ohm/k m	0.492	0.689	0.986	1.38
v)	Shape of conductor		Stranded circular-compacted			
vi)	Short circuit rating for 1 sec	kA	6.58	4.7	3.29	2.35
vii)	Material of insulation		XLPE Insulation as per IS 14255			
viii)	Thickness of insulation	mm	1.5	1.5	1.2	1.2
ix)	Min Breaking load of messenger wire	KN	19.7	14	9.8	7
14	Core Identification		RIDGES for Phase identification: 1 ridge for R phase 2 ridges for Y phase 3 ridges for B phase For neutral core identification non-contact type laser printing or ink jet printing to be provided with 'N' printed on it at every span of 1 mtr.			
15	Formation of cable		3 phase cores & 1 street lighting core xlpe insulated are laid up over insulated messenger with R-H direction of Lay			
17	Maximum conductor temperature during continuous operation (RYBN)	Deg C	90	90	90	90
18	Maximum conductor temperature during Short circuit (RYBN)	Deg C	250	250	250	250
19	Standard Drum Length	Mtr	500	500	500	500
20	Tolerance in Drum length	%	+/-5%	+/-5%	+/-5%	+/-5%
21	Reference Standard		IS 14255			
22	Embossing on XPLE cable		Embossing on phase insulation of the cable: manufacturer name 1100V, size of cable, ISI, month & year of manufacturing, Property of TPCODL/TPNODL/TPWODL/TPSODL, PO number & date.			



**Specification No:** [ENG-LV-3002](#)

**Specification Name:**  
Specification for LT AB cable 3  
Cores insulated messenger street  
light

SL NO	DESCRIPTION	UNITS	1C X 35 mm <sup>2</sup> (P) + 1C X 25 mm <sup>2</sup> (M)	3C×50 mm <sup>2</sup> (P)+1C×35 mm <sup>2</sup> (M)	3C X 35 mm <sup>2</sup> (P) + 1C X 25 mm <sup>2</sup> (M)
1	Type of Cable		LT ABC cable with cross linked polyethylene insulated Phase core twisted around the insulated neutral earth cum messenger wire		
2	Size of Aerial Bunched cable		1C X 35 mm <sup>2</sup> (P) + 1C X 25 mm <sup>2</sup> (M)	3C×50 mm <sup>2</sup> (P)+1C×35 mm <sup>2</sup> (M)	3C X 35 mm <sup>2</sup> (P) + 1C X 25 mm <sup>2</sup> (M)
3	Rated Voltage	kV	1.1	1.1	1.1
4	System Voltage	kV	0.415-0.433	0.415-0.433	0.415-0.433
5	Nominal Area of Phase Conductor	mm <sup>2</sup>	35	50	35
6	Nominal Area of Messenger	mm <sup>2</sup>	25	35	25
7	Phase Core		Stranded compacted circular Aluminum Conductor, Extruded XLPE Insulated		
8	Neutral core & Messenger Wire		Stranded compacted circular aluminum alloy conductor, Extruded XLPE insulated		
9	Maximum conductor temperature during continuous operation	Deg C	90	90	90
10	Maximum conductor temperature during shortcircuit	Deg C	250	250	250
11	<b>Phase Core RYB insulated</b>				
a)	<b>Conductor</b>				
(i)	Material		EC Grade Aluminum of H4 Grade to IS: 8130:1984	EC Grade Aluminum of H4 Grade to IS: 8130:1984	EC Grade Aluminum of H4 Grade to IS: 8130:1984
(ii)	No. of Cores & Nominal Size	mm <sup>2</sup>	1C*35	3C*50	3C*35
(iii)	Minimum number of Strand wires		6	6	6
(iv)	Diameter		Shall be suitably selected to meet conductor DC resistance as per IS 8130		

 	 	<b>Specification No:</b> <a href="#">ENG-LV-3002</a>  <b>Specification Name:</b> Specification for LT AB cable 3 Cores insulated messenger street light
--	--	--

(v)	Max. DC Resistance of phase conductor at 20 deg. C	Ω/km	0.868	0.641	0.868
(vi)	Shape of Conductor		Stranded Compacted Circular		
(vii)	Short Circuit current rating of conductor for 1 sec	kA	3.29	4.7	3.29
(viii)	Continuous current rating in air at 40Deg.C	A	125	149	125
b)	<b>Insulation</b>				
i)	Material		XLPE Insulation as per IS 14255:1995		
ii)	Nominal Thickness	mm	1.2	1.5	1.2
iii)	Tolerance in Insulation Thickness	mm	XLPE Insulation as per IS 14255:1995		
c)	<b>Messenger wire</b>				
i)	Material		Aluminum Alloy Wire	Aluminum Alloy Wire	Aluminum Alloy Wire
ii)	Nominal size	mm <sup>2</sup>	25	35	25
iii)	No. and Nominal Dia. of each strand	No./m m	7/2.14	7/2.54	7/2.14
iv)	Calculated Maximum resistance at 20 degC	ohm/k m	1.38	0.986	1.38
v)	Shape of conductor		Stranded circular-compact	Stranded circular-compact	Stranded circular-compact
vi)	Short circuit rating for 1sec	kA	2.35	3.29	2.35
vii)	<b>Material of insulation</b>		XLPE Insulation as per IS 14255	XLPE Insulation as per IS 14255	XLPE Insulation as per IS 14255
viii)	Thickness of insulation	mm	1.2	1.2	1.2
ix)	Min Breaking load of messenger wire	KN	7	9.8	7



**Specification No:** [ENG-LV-3002](#)

**Specification Name:**  
Specification for LT AB cable 3  
Cores insulated messenger street  
light

12	Core Identification		RIDGES for Phase identification: 1 ridge for R phase 2 ridges for Y phase 3 ridges for B phase. For neutral core identification non-contact type laser printing or ink jet printing to be provided with 'N' printed on it at every span of 1 mtr.		
13	Formation of cable		1 phase core XLPE insulated shall be twisted around the insulated earth cum messenger wire, with R-H direction of lay	3 phase cores XLPE insulated shall be twisted around the insulated earth cum messenger wire, with R-H direction of lay	3 phase cores XLPE insulated shall be twisted around the insulated earth cum messenger wire, with R-H direction of lay
14	Continuous current rating in air at 40DegC of phase conductor	A	125	149	125
15	Maximum conductor temperature during continuous operation (RYBN)	Deg C	90	90	90
16	Maximum conductor temperature during short circuit (RYBN)	Deg C	250	250	250
17	Standard Drum Length	Mtr	500	500	500
18	Tolerance in Drum length	%	+/-5%	+/-5%	+/-5%
19	Reference Standard		IS 14255		
20	Embossing on XPLE cable		Embossing on phase insulation of the cable: manufacturer name 1100V, size of cable, ISI, month & year of manufacturing, Property of TPCODL/ TPNODL/ TPWODL/ TPSODL, PO number & date.		



	<p><b>Specification No:</b> <a href="#">ENG-LV-3002</a></p> <p><b>Specification Name:</b> Specification for LT AB cable 3 Cores insulated messenger street light</p>
---	--

## 5.GENERAL CONSTRUCTION

### 5.1 Conductors:

- 5.1.1 All conductors shall be Class 2, Stranded, compared circular, High electrical conductivity, Aluminum, Grade H2/H4 as per IS 8130:1984.
- 5.1.2 Before stranding, the conductor shall be circular in cross section, uniform in quality, solid, smooth and free from scale, sharp edges and other defects.
- 5.1.3 Conductor shall conform to the standards for permissible number of joints in any one of the single wires forming every complete length of conductor, for location of joints in same layer of conductors and for method of making such joints. No joint shall be made in any conductor after it is stranded.
- 5.1.4 All conductors shall be of high electrical conductivity Aluminum as specified, conforming to requirement of relevant standards.

### 5.2 INSULATION

- 5.2.1 The insulating material shall be Cross Linked Polyethylene (XLPE) applied by extrusion as per latest IS:14255 and its latest amendments.
- 5.2.2 The insulation shall be both heat and moisture resistant and shall be suitable for continuous operation at conductor temperature of 90 Degree Centigrade, rising momentarily to 250 Degree Centigrade under short circuit conditions.
- 5.2.3 It shall be free from any foreign material or porosity visible to unaided eye. The insulation shall be so applied that it fits closely to the conductor and it shall be possible to remove insulation without damaging the conductor. The XLPE insulation shall be ultraviolet protected for operation in direct sunlight.
- 5.2.4 It shall be free from any foreign material or porosity visible to unaided eye. The insulation shall be so applied that it fits closely to the conductor and it shall be possible to remove insulation without damaging the conductor. Average thickness of the insulation shall not be less than nominal value specified in latest IS:14255 with latest amendments. The tolerance on the thickness shall be as specified in latest IS:14255.
- 5.2.5 The insulating material shall have excellent electrical properties with regard to resistivity, dielectric constant and loss factor and shall have high tensile strength and resistance to abrasion. This shall not deteriorate at elevated temperatures or when immersed in water. The insulation shall be preferably fire resistant and resistant to chemicals like acids, alkalis, oils and ozone.

### 5.3 MESSENGER WIRE

The insulated messenger wire shall be made of aluminum alloy, generally conforming to latest IS:14255. The conductor shall be of heated aluminum-magnesium-silicon alloy wires containing approximate 0.5% magnesium and approximately 0.5% silicon conforming to IS 398(Part 4). Insulation shall be as per IS 14255.

	<p><b>Specification No:</b> <a href="#">ENG-LV-3002</a></p> <p><b>Specification Name:</b> Specification for LT AB cable 3 Cores insulated messenger street light</p>
---	--

#### 5.4 CORE IDENTIFICATION

The following shall be embossed on the one side of the core:

RIDGES REQUIRED for Phase identification:

- 1 ridge for R phase
- 2 ridges for Y phase
- 3 ridges for B phase

For neutral core identification non-contact type laser printing or ink jet printing to be provided with 'N' printed on it at every span of 1 mtr.

#### 5.5 LAYING OF CORES

Cores shall be laid up with a right-hand lay, and shall have a lay length not exceeding  $28(d1+d2)$ , where;

**d1** is the core diameter, including sheath, in mm.

**d2** is the diameter of the messenger, including the outer protective covering where applicable, in mm.

#### 5.6 STRANDING

The wire used in the construction of a stranded conductor shall, before and after stranding, satisfy all the relevant requirements of IS 398(Part-IV): 1994. The lay ratio of the different layers shall be within the limits given in IS 398(Part-IV): 1994. The successive layers shall have opposite directions of lay, the outermost layer being right-handed. The wires in each layer shall be evenly and closely stranded. The lay ratio of any layer shall not be greater than the lay ratio of layer immediately beneath it.

#### 5.7 CABLE DRUM

Cables shall be furnished in the specified reels or coil lengths of 500 meters. Drums shall be of non-returnable wooden drums as per IS 10418:1982 and the drums should be free from defects such as through cracks, knots, warps and split. The ends of the cables shall be suitably sealed by means of non-hygroscopic sealing. The tolerance on the Drum length shall be +/- 5% / as per PO terms.

#### 6. MARKING:

The cable shall carry the following information either stenciled on the drum or contained in a label attached to it:

- a) Reference to the Standards.
- b) Manufacturer's name.
- c) Type of cable.
- d) Voltage grade.
- e) Number of cores.
- f) Nominal cross-section area of the conductor.
- g) Length of the cable on the drum.
- h) Length of the cable perm.

	<b>Specification No:</b> <a href="#">ENG-LV-3002</a>  <b>Specification Name:</b> Specification for LT AB cable 3 Cores insulated messenger street light
---	--

- i) Marking of PO
- j) Direction of rotation of the drum.
- k) Gross mass.
- l) Country of manufacture.
- m) Year of manufacture.
- n) ISI Certification mark.

## 7. TESTS:

All routine, acceptance & type tests shall be carried out in accordance with the relevant IS/IEC. All Routine/acceptance tests shall be witnessed by the purchaser/his authorized representative. All the components shall also be type tested, as per the relevant standards. Following tests shall be necessarily conducted on the LT ABC cables in addition to others specified in the IS/IEC/SANS Standards.

### 7.1 ACCEPTANCE TESTS

- i) Tensile test (for phase/street light conductor)
- ii) Wrapping Test (for phase/street light conductor)
- iii) Breaking load test for messenger conductor
- iv) Elongation test for messenger conductor
- v) Conductor Resistance test for messenger and phase conductor.
- vi) Test for thickness of insulation
- vii) Hot set test for XLPE insulation
- viii) Tensile strength and elongation test at break for test of insulation
- ix) High voltage test.
- x) Insulation resistance (volume resistivity test).
- xi) UV test for XLPE insulation (black carbon content and dispersion test).

### 7.2 ROUTINE TESTS

- i) Conductor resistance test
- ii) High voltage test

### 7.3 TYPE TESTS

- i) Tests on phase/street light Conductor
  - a) Tensile test
  - b) Wrapping test
  - c) Resistance test
- ii) Tests on messenger Conductor
  - a) Breaking load test
  - b) Elongation test.
  - c) Resistance test.

iii) Physical Test for XLPE Insulation:

	<p><b>Specification No:</b> <a href="#">ENG-LV-3002</a></p> <p><b>Specification Name:</b> Specification for LT AB cable 3 Cores insulated messenger street light</p>
---	--

- a) Tensile strength and elongation at break
- b) Ageing in air oven
- c) Hot test
- d) Shrinkage test
- e) Water absorption (gravimetric)
- f) Carbon black:
  - 1) Content
  - 2) Dispersion.
- g) Insulation resistance (Volume resistivity) test.
- iv) Test for thickness insulation.
- v) High voltage test.

#### 7.4 OPTIONAL TESTS

- i) Bending Test

#### 8. TYPE TEST CERTIFICATES:

The Bidder shall furnish the type test certificates of the cable for the tests as mentioned as above as per the corresponding standards. All the tests shall be conducted at **CPRI/ ERDA/ Approved Govt. Labs by TATA ODISHA DISCOM as** per relevant IS. Type tests should have been conducted in certified Test laboratories during the period not exceeding 10 years from the date of opening the bid. In the event of any discrepancy in the test reports, i.e., any test report not acceptable, or any/all type tests (including additional same shall be carried out without any cost implication to TPCODL/ TPNODL/ TPSODL/ TPWODL.

#### 9. PRE-DISPATCH INSPECTION:

The material shall be subject to inspection by a duly authorized representative of the TPCODL/ TPNODL/ TPSODL/ TPWODL. Inspection may be made at any stage of manufacture at the discretion of the purchaser and the equipment, if found unsatisfactory as to workmanship or material, the same is liable to rejection. Bidder shall grant free access to the places of manufacturing to TPCODL/ TPNODL/ TPSODL/ TPWODL's representatives at all times when the work is in progress. Inspection by the TPCODL/ TPNODL/ TPSODL/ TPWODL or its authorized representatives shall not relieve the bidder of his obligation of furnishing equipment in accordance with the specifications. Material shall be dispatched after specific MDCC (Material Dispatch Clearance Certificate) is issued by TPCODL/ TPNODL/ TPSODL/ TPWODL.

Following documents shall be sent along with material.

- a) Test reports
- b) MDCC issued by TPCODL/ TPNODL/ TPSODL/ TPWODL
- c) TPCODL/ TPNODL/ TPSODL/ TPWODL Invoice in duplicate

	<p><b>Specification No:</b> <a href="#">ENG-LV-3002</a></p> <p><b>Specification Name:</b> Specification for LT AB cable 3 Cores insulated messenger street light</p>
---	--

- d) Packing list
- e) Drawings & catalogue
- f) Guarantee / Warrantee card
- g) Delivery Challan
- h) Other Documents (as applicable).

**10. INSPECTION AFTER RECEIPT AT STORE:**

The material received at TPCODL/ TPNODL/ TPSODL/ TPWODL, Odisha store will be inspected for acceptance and shall be liable for rejection, if found different from the reports of the pre-dispatch inspection and one copy of the report shall be sent to Engineering department and contracts department.

**11. GUARANTEE:**

Bidder shall stand guarantee towards design, materials, workmanship & quality of process/ manufacturing of items under the contract for due and intended performance of the same, as an integrated product delivered under this contract. In the event any defect is found by the company up to a period of 30 months from the date of commissioning or 36 months from the date of last supplies made under the contract, whichever is earlier, (the time scale of 30/36 months could be enhanced subject to mutual agreements). Bidder shall be liable to undertake to replace/rectify such defects at his own costs, within mutually agreed timeframe, and to the entire satisfaction of the Company, failing which the Company will be at liberty to get it replaced/rectified at supplier's risks and costs and recover all such expenses plus the Company's own charges (@ 20% of expenses incurred), from the supplier or from the "Security cum Performance Deposit" as the case may be.

The bidder shall further be for "free replacement" for another period of three years from the end of the guarantee period for any latent defects if noticed and reported by the purchaser.

**12. PACKING AND TRANSPORT:**

The cable shall be wound on wooden drums and packed in line with requirements of IS 10418-1982. The ends of the cable shall be sealed by means of non-hygroscopic sealing material.

Bidder shall ensure that all the equipment covered under this specification shall be prepared for rail/road transport in a manner so as to protect the equipment from damage in transit.

**13. TENDER SAMPLE:**

Bidder shall submit the sample of material with the offer (in case of first supply to TPCODL/ TPNODL/ TPSODL/ TPWODL).

**14. QUALITY CONTROL:**

The bidder shall submit Quality Assurance Plan (QAP) indicating the various stages of inspection,

	<p><b>Specification No:</b> <a href="#">ENG-LV-3002</a></p> <p><b>Specification Name:</b> Specification for LT AB cable 3 Cores insulated messenger street light</p>
---	--

the tests and checks which will be carried out on the material of construction, components during manufacture and bought out items and fully assembled component and equipment after finishing. As part of the plan, a schedule for stage and final inspection within the parameters of the delivery schedule shall be furnished. The Purchaser's engineer or its nominated representative shall have free access to the manufacturer's/sub-supplier's works to carry out inspections.

**15. TESTING FACILITIES:**

Bidder shall have adequate in-house testing facilities for carrying out all routine tests & acceptance tests as per relevant International/Indian standards.

**16. MANUFACTURING FACILITIES:**

The successful bidder shall submit the bar chart for various manufacturing activities clearly elaborating each stage, with quantity. This bar chart should be in line with the Quality assurance plan submitted with the offer.

**17. SPARES, ACCESSORIES AND TOOLS**

The bidder shall provide a list of complete set of accessories and tools required for erection and maintenance of LT ABC along with the installation procedure.





**18. DRAWINGS AND DOCUMENTS:**

Following drawings and documents shall be prepared based on TPCODL/ TPNODL/ TPSODL/ TPWODL Specifications and statutory requirements with complete BOM and shall be submitted with bid.

- a) Completely filled in Schedule "A" Guaranteed Technical Particulars.
- b) Work Experience details
- c) Type test certificates.
- d) General descriptions of the equipment and all components including brochure.

After the award of the contract, four (4) copies of the drawings, drawn to scale, describing the equipment in detail shall be forwarded for approval and shall subsequently provide four (4) complete sets of final drawings, one of which shall be auto positive suitable for reproduction, before the dispatch of the equipment. Soft copy (compact Disk CD) of all the drawing, GTP, test certificates shall be submitted after the final approval of the same to the purchaser.

Following Drawings/Documents shall be submitted after the award of the contract.

 	 	<b>Specification No:</b> <a href="#">ENG-LV-3002</a>  <b>Specification Name:</b> Specification for LT AB cable 3 Cores insulated messenger street light
--	--	--





SL.No	Description	For Approval	For Review information	Final Submission
1	Technical Particulars	✓		✓
2	Manual/Catalogues/drawings for all components		✓	
3	Technical details and test certificates of XLPE compound		✓	✓
4	Cross sectional area of the cable		✓	✓
5	Installation instructions		✓	✓
6	Instructions for use		✓	✓
7	Transport/shipping dimension drawing		✓	✓
8	QA & QC Plan	✓	✓	✓
9	Routine, Acceptance and type test certificates	✓	✓	✓
10	Fault level calculation for armor and manual	✓	✓	✓

All the documents and drawings shall be in English language only.

Instruction Manuals: Bidder shall furnish two (2) soft copies (CD) and four (4) hard copies of nicely bound manual (in English Language) covering erection and maintenance instructions and all relevant information pertaining to the main equipment as well as auxiliary devices.

**19. SCHEDULE- "A" GUARANTEED TECHNICAL PARTICULARS: (To be furnished by bidder)**

All clauses and points in the specification to be complied as per **Clause Number 4.0 (GENERAL TECHNICAL PARAMETERS) & Clause Number 5.0 (GENERAL CONSTRUCTION)**

 	 	<b>Specification No:</b> <a href="#">ENG-LV-3002</a>  <b>Specification Name:</b> Specification for LT AB cable 3 Cores insulated messenger street light
--	--	--

**20. SCHEDULE "B" DEVIATIONS:**

**(TO BE ENCLOSED WITH TECHNICAL BID)**

All deviations from this specification shall be set out by the Bidders, clause by Clause in this schedule. Unless specifically mentioned in this Schedule, the tender shall be deemed to confirm the purchaser's specifications:

SL. No	Clause No.	Details of deviation with justifications

We confirm that there are no deviations apart from those detailed above.

Seal of the Company:

Signature

Designation



# **STANDARD TECHNICAL SPECIFICATION COVER SHEET**

**Specification No. : ENG-GEN-4005**

**Specification Name : GALVANISED IRON (GI) FLATS OF DIFFERENT SIZES**

<b>Ranjan Kumar Sahoo</b>	<b>SATYA PRASAD NAYAK</b>	<b>SHANTAPRIYA JENA</b>	<b>JYOTIPRAKASH MOHANTY</b>	<b>Shailendra Kumar Jaiswal</b>	<b>SHIRISH SHARAD DIKAY</b>
Prepared by	Reviewed by	Reviewed by	Reviewed by	Approved by	Released by
TPSODL	TPCODL	TPNODL	TPWODL	TPSODL	TPSODL
22-12-2022	22-12-2022	22-12-2022	22-12-2022	22-12-2022	22-12-2022

*Property of TATA POWER ODISHA DISCOMs – Not to be reproduced without permission of TPCODL/ TPNODL/ TPSODL/ TPWODL*

## **CONTENTS**

1. SCOPE
2. APPLICABLE STANDARDS
3. CLIMATIC CONDITIONS OF INSTALLATION
4. GENERAL TECHNICAL REQUIREMENTS
5. GENERAL CONSTRUCTION
6. NAME PLATE AND MARKING
7. TESTS
8. TYPE TEST CERTIFICATES
9. PRE-DISPATCH INSPECTION
10. INSPECTION AFTER RECEIPT AT STORES
11. GUARANTEE
12. PACKING
13. TENDER SAMPLE
14. TRAINING
15. QUALITY CONTROL
16. MINIMUM TESTING FACILITIES
17. MANUFACTURING ACTIVITIES
18. SPARES, ACCESSORIES AND TOOLS
19. DRAWINGS AND DOCUMENTS
20. GUARANTEED TECHNICAL PARTICULARS
21. SCHEDULE OF DEVIATIONS

1.0	SCOPE	This specification covers technical requirements of design, manufacturing, testing, Inspection, Supply & transportation of Hot dip Galvanised Iron (GI) Flat 25X3 MM, 25X4 MM, 25X6 MM, 50X6 MM, 75X10 MM, 90X6 MM at TPCODL/TPNODL/TPSODL/TPWODL stores/site.
2.0	APPLICABLE STANDARDS	<p>The equipment covered by this specification shall unless otherwise stated, be designed, manufactured and tested in accordance with the latest editions of the following Indian, International Standards and shall conform to the regulations of the local Statutory authorities:</p> <ul style="list-style-type: none"> <li>•</li> <li>• IS 1239 (Part1): Specification for Steel Tubes, Tubulars &amp; other wrought steel fittings.</li> <li>• IS 1239 (Part2): Specification for Steel Tubes, Tubulars &amp; other steel fittings.</li> <li>• IS 228: Method for chemical analysis of steels.</li> <li>• IS 4736 : Specification for Hot dip zinc coating on mild steel tubes</li> <li>• IS 4759: Specification for Hot dip zinc coating on structural steel and other allied products.</li> <li>• IS 1387: General requirements for the supply of metallurgical materials.</li> <li>• IS 1608: Mechanical testing of metals-Tensile Strength.</li> <li>• IS 4711: Methods for sampling of steel pipes, tubes and fittings.</li> <li>• IS 4740: Code of practice for packaging of steel tubes.</li> <li>• IS 10748: Hot rolled steel strip for welded tubes &amp; pipes.</li> <li>• IS 12278: Method for ring tensile test on metallic tubes.</li> <li>• IS 3043-1987: Code of practice for earthing.</li> <li>• IS 1367: Technical supply conditions for threaded steel fasteners.</li> <li>• IS 14394: Industrial fastners-Nuts of product GradeC- Hot Dip Galvanised.</li> <li>• IS 2016:-1997: Specification for plain washers.</li> <li>• IS 1730-1989: Steel plates, sheets, strips and flats for structural</li> <li>• And general engineering purpose-Dimensions</li> <li>• IS 814-2004: covered electrodes for manual metal Arc welding</li> <li>• of carbon and carbon Manganese steel- specification.</li> <li>• IS: 2629(1966)- Recommended practice for hot dip galvanized of Iron Earthing Strips</li> <li>• IS: 2633(1972)- Methods of testing weight, thickness &amp; uniformity of coating on hot dip galvanized articles.</li> <li>• IS: 5358(1969)- Specification for hot dip galvanized coating on fastness I</li> <li>• IS:3203-Specification for Electroplating</li> <li>• IS: 4759(1968)- IS: 4759(1968)</li> <li>• IS 2062</li> </ul> <p><i>*In case of any conflict on any technical particular in the specification, the stricter requirement mentioned in the relevant standard shall be valid.</i></p>

<b>3.0</b>	<b>CLIMATIC CONDITIONS OF INSTALLATION</b>	1	Maximum ambient temperature	50 deg C
		2	Max. Daily average ambient temp	35 deg C
		3	Min Ambient Temperature	0 deg C
		4	Maximum Humidity	95%
		5	Average Annual Rainfall	150cm
		6	Average No. of rainy days per annum	120
		7	Altitude above MSL not exceeding	1000m
		8	Wind Pressure	300 Km/hr
		9	Earthquakes of an intensity in horizontal direction	equivalent to seismic acceleration of 0.3g
		10	Earthquakes of an intensity in vertical direction	equivalent to seismic acceleration of 0.15g (g being acceleration due to gravity)
		<p>TPCODL/TPNODL/TPSODL/TPWODL service area has heavy saline conditions along the coast and High cyclonic Intensity winds with speed upto 300 Kmph. The atmosphere is generally laden with mild acid and dust in suspension during the dry months and is subjected to fog in cold months.</p>		
<b>4.0</b>	<b>GENERAL TECHNICAL REQUIREMENTS</b>	<p><b>MATERIAL</b></p> <p>Supplier has to purchase raw materials (MS Flat) as per relevant IS at his own cost. The zinc required for galvanizing shall be quality Zn-99.95% or better Zinc grade &amp; shall confirm to IS and its latest amendments.</p> <p>The Supplier shall make his own arrangement for procurement before the commissioning of work, sufficient quantity of electrolytic zinc of proper quality for galvanizing. The Supplier shall however not link the delivery period with the supply of zinc. TPCODL/TPNODL/TPSODL/TPWODL is at liberty to have sample of zinc used and to test in any laboratory at his own cost and reject the particular supply, is found below standard.</p> <p>All raw materials required for galvanizing etc. and for complete execution of work shall be stocked in adequate quantities by the Supplier to ensure that the progress of work is not hampered.</p>		

SL. NO.	TECHNICAL PARTICULARS	Requirement
1	Material	Hot-Dip Galvanized Flat
2	Relevant Standard	IS: 2062, IS: 2633, IS: 2629, IS: 4759
3	Make	SAIL, TATA Steel, ESSAR, JSW Steel and TATA steel BSL
4	Grade of Steel	E 250 A
5	Minimum Tensile Strength in Mpa	410
6	Yield Stress in Mpa	250
7	Percentage Elongation (Min.) at Gauge Length	23%
8	Bend Test (Internal Dia)	Min-2t
9	Mass of Zinc Coating	705 gm/m <sup>2</sup>
10	Zinc Coating Thickness & No of Dips	100 Micron (6 Dip)
11	Chemical composition	Grade: E 250 A (As per IS: 2062)
12	Standard length of supply	6 Metre Long
13	Tolerances	As per IS 1852 latest Amendment

5.0	<p align="center"><b>GENERAL CONSTRUCTION</b></p> <p>GI Flat intended for different use in electricity distribution utility. The zinc coating shall be uniform. The materials shall be strictly from approved vendors' i.e. SAIL, TATA Steel, ESSAR, JSW Steel and TATA steel BSL &amp; Billets(grade E250) with re rolling shall be allowed for mentioned MAKE. Documentary evidence certifying the raw material lifted from the approved vendor, which should not be less than the ordered quantity. Similarly the zinc for galvanization shall be procured from Hindustan zinc LTD. or Vedanta LTD. And the firm shall submit the documentary evidence certifying not less than the ordered quantity of zinc lifted from the approved vendor. The hot dip galvanization shall be done only after the all fabrication and welding done. The nut bolt, &amp; washers provided shall be as per relevant IS.</p> <p><b>5.1 Mass of the Flats are as follows:-</b></p> <p>a) 25X3 mm: - 0.589kg/m</p> <p>b) 25X4 mm: - 0.785kg/m</p> <p>c) 25X6 mm: - 1.18kg/m</p> <p>d) 50x6 mm: - 2.36kg/m</p>
-----	--

e) 75x10 mm: -5.89kg/m

f) 90x6 mm: -4.24kg/m

**5.2 Chemical Composition**

Chemical composition for Fe 410 WA Grade

a)C - 0.23% Max

b)Mn - 1.5% Max

c)S - 0.045% Max

d)P - 0.045%Max

e)SI - 0.40% Max

f) CE (Carbon Equivalent)- 0.42%

**5.3 Galvanization:**

All flats shall be hot dip galvanized, are as following:

- a) All galvanizing shall be carried out by the hot dip process, in accordance with Specification IS 2629.
- b) The zinc coating (705 gms per sq.mt / 100Micron,6 dips) shall be smooth, continuous and uniform. It shall be free from acid spot and shall not scale, blister or be removable by handling or packing.
- c) There shall be no impurities in the zinc or additives to the galvanic bath which could have a detrimental effect on the durability of the zinc coating. Purity of zinc shall be Zn 99.95% or better.
- d) In the event of damage to the galvanizing the method used for repair shall be subject to the approval of the Engineer in Charge or that of his representative. Repair of galvanization at site will not be permitted in any situation.
- e) Partial immersion of the work shall not be permitted and the galvanizing tank must therefore be sufficiently large to permit galvanizing to be carried out by one immersion.

After galvanizing no drilling or welding shall be performed on the galvanized parts. To avoid the formation of white rust galvanized materials shall be stacked during

		transport and stored in such a manner as to permit adequate ventilation. Sodium dichromate treatment shall be provided to avoid formation of white rust after hot dip galvanization. The galvanized steel shall be subjected to test as per IS-2633.
<b>6.0</b>	<b>NAME PLATE AND MARKING</b>	The body of the device shall be appropriately marked with "TPCODL/TPNODL/TPSODL/TPWODL" , Manufacture's name or trademark and Year of Manufacturing. at suitable location such that it is permanent and does not harm the body of the device.
<b>7.0</b>	<b>TESTS</b>	All routine, acceptance & type tests shall be carried out in accordance with the relevant IS.
<b>7.i)</b>	<b>TYPE TEST</b>	<p>The following tests shall constitute the type tests and shall be carried out as per IS: 1239 Part-1: 2004(Latest Amendment)</p> <ol style="list-style-type: none"> <li>1)Test for Mechanical Properties (As per 1239 Part-1: 2004 or Latest Amendment clause no.14.1 &amp; 14.1.1) <ul style="list-style-type: none"> <li>• Percentage of Elongation.</li> <li>• Tensile strength.</li> </ul> </li> <li>2) Mass of zinc coating. (As per 4736:1986 or Latest Amendment clause no.5.1)</li> <li>3) Chemical composition. (As per 1239 Part-1: 2004 or Latest Amendment clause no.6.1.1)</li> </ol>
<b>7.ii)</b>	<b>ROUTINE/ ACCEPTANCE TEST</b>	<p>The following tests shall be got conducted in presence of TPCODL/TPNODL/TPSODL/TPWODL representative as per IS: 1239 Part-1: 2004 (Latest Amendment) on the samples taken from the offered lot material for the purpose of acceptance of that lot of material.</p> <ol style="list-style-type: none"> <li>1) Dimension of GI Flat. (As per IS 1239 Part-1: 2004 clause No.9.1 a&amp;b)-Test shall be performed.</li> <li>2) Chemical composition (Manufacturer's Test Certificate for raw material-Document Review only.)</li> <li>3) Mass of zinc coating. (As per 4736:1986 or Latest Amendment clause no.5.1)-Test shall be performed.</li> <li>4) Test for mechanical properties (Manufacturer's Test Certificate for raw material-Document Review only.)</li> <li>5) Galvanizing/Electroplating test</li> <li>6) Visual Inspection test to confirm products free from any defects</li> </ol>
<b>8.0</b>	<b>TYPE TEST CERTIFICATES</b>	The Bidder shall furnish the type test certificates for the tests as mentioned above as per the corresponding standards. All the tests shall be conducted at CPRI / ERDA / Other Government Labs/ NABL accredited Lab as per relevant IS. Type tests should have been conducted during the period not exceeding 5 years from the date of opening the bid. In the event of any discrepancy in the test reports, i.e. any test report not acceptable, same shall be carried out without any cost implication to TPCODL/TPNODL/TPSODL/TPWODL .

<p><b>9.0</b></p>	<p><b>PRE DISPATCH INSPECTION</b></p>	<p>The Material shall be subject to inspection by a duly authorized representative of the TPCODL/TPNODL/TPSODL/TPWODL . Inspection may be made at any stage of manufacture at the discretion of the purchaser and the equipment, if found unsatisfactory as to workmanship or material, the same is liable to rejection. Bidder shall grant free access to the places of manufacture to TPCODL/TPNODL/TPSODL/TPWODL 's representatives at all times when the work is in progress. Inspection by the TPCODL/TPNODL/TPSODL/TPWODL or its authorized representatives shall not relieve the bidder of his obligation of furnishing equipment in accordance with the specifications. Material shall be dispatched after specific MDCC (Material Dispatch Clearance Certificate) is issued by TPCODL/TPNODL/TPSODL/TPWODL . The pre-dispatch inspection shall be carried out as per annexure-IV</p> <p>Following documents shall be sent along with material</p> <ul style="list-style-type: none"> <li>a) Test reports</li> <li>b) MDCC issued by TPCODL/TPNODL/TPSODL/TPWODL</li> <li>c) Invoice in duplicate</li> <li>d) Packing list</li> <li>e) Drawings &amp; catalogue</li> <li>f) Guarantee / Warrantee card</li> <li>g) Delivery Challan</li> <li>h) Other Documents (as applicable)</li> </ul>
<p><b>10.0</b></p>	<p><b>INSPECTION AFTER RECEIPT AT STORES</b></p>	<p>The material received at TPCODL/TPNODL/TPSODL/TPWODL store will be inspected for acceptance and shall be liable for rejection, if found different from the reports of the pre-dispatch inspection and one copy of the report shall be sent to each QA and Plant Engineering group.</p>
<p><b>11.0</b></p>	<p><b>GUARANTEE</b></p>	<p>Bidder shall stand guarantee towards design, materials, workmanship &amp; quality of process / manufacturing of items under this contract for due and intended performance of the same, as an integrated product delivered under this contract. In the event any defect is found by the Purchaser up to a period of 12 months from the date of commissioning or 18 months from the date of last supplies made under the contract whichever is earlier, Bidder shall be liable to undertake to replace/rectify such defects at its own costs, within mutually agreed time frame, and to the entire satisfaction of the Purchaser, failing which the Purchaser will be at liberty to get it replaced/rectified at Bidder's risks and costs and recover all such expenses plus the Purchaser's own charges (@ 20% of expenses incurred), from the Bidder or from the "Security cum Performance Deposit" as the case may be.</p> <p>Bidder shall further be responsible for 'free replacement' for another period of THREE years from the end of the guarantee period for any 'Latent Defects' if noticed and reported by the Purchaser.</p>
<p><b>12.0</b></p>	<p><b>PACKING</b></p>	<p>Bidder shall ensure that the equipment covered under this specification shall be prepared for rail/road transport in a manner so as to protect the equipment from damage in transit.</p>
<p><b>13.0</b></p>	<p><b>TENDER SAMPLE</b></p>	<p>Samples to be provided as required to TPCODL/TPNODL/TPSODL/TPWODL</p>



		Engineering Dept.
14.0	<b>TRAINING</b>	Not Applicable
15.0	<b>QUALITY CONTROL</b>	The bidder shall have a prove track of not less than 10 years in GI Flat in manufacturing and servicing in national or international market. The bidder shall submit with the offer Quality assurance plan indicating the various stages of inspection, the tests and checks which will be carried out on the material of construction, components during manufacture and bought out items and fully assembled component and equipment after finishing. As part of the plan, a schedule for stage and final inspection within the parameters of the delivery schedule shall be furnished. The Purchaser's engineer or its nominated representative shall have free access to the manufacturer's/sub-supplier's works to carry out inspections.
16.0	<b>MINIMUM TESTING FACILITIES</b>	Bidder shall have adequate in house testing facilities for carrying out all routine tests & acceptance tests as per relevant Indian standards.
17.0	<b>MANUFACTURING ACTIVITIES</b>	The successful bidder will have to submit the bar chart for various manufacturing activities clearly elaborating each stage, with quantity. This bar chart should be in line with the Quality assurance plan submitted with the offer. This bar chart will have to be submitted within 15 days from the release of the order.
18.0	<b>SPARES ACCESSORIES AND TOOLS</b>	To be provided by BA
19.0	<b>DRAWINGS AND DOCUMENTS</b>	<p>Constructional drawings are attached as annexure-I, annexure-II, annexure-III should be followed for fabrication.</p> <p>Following documents shall be prepared based on TPCODL/TPNODL/TPSODL/TPWODL specifications and statutory requirements with complete BOM and shall be submitted with the bid:</p> <ol style="list-style-type: none"> <li>1. Completely filled in Technical Particulars along with Size and weight/sq.m of G.I. Flat, Standard Length, Galvanization Process, Galvanization thickness</li> <li>2. General description of the equipment and all components including brochures.</li> <li>3. Bill of Material</li> <li>4. Type test Certificates</li> <li>5. Experience List.</li> </ol> <p>After award of order Soft of all the drawing, GTP, test certificates shall be submitted for the final approval of the same to the purchaser.</p> <p>Following Drawings/Documents shall be submitted after the award of the contract:</p>

SI. No	Description	For Approval	For Review Information	Final Submission
1	General Technical Parameters	√		√
2	Manual/Catalogues/drawings for all components.		√	
3	Technical details and test certificates of the component.		√	√
4	Instructions for use		√	√
5	Transport/shipping dimension drawing		√	√
6	QA & QC Plan	√	√	√
7	Routine, Acceptance and Type test Certificates	√	√	√

All the Documents and Drawings shall be in English Language.

<b>20.0</b>	<b>GUARANTEED TECHNICAL PARTICULARS</b>	Clause wise compliance shall be provided by bidders
-------------	---	---

<b>21.0</b>	<b>SCHEDULE OF DEVIATIONS</b>	<b><u>(TO BE ENCLOSED WITH THE BID)</u></b>				
		<p>All deviations from this specification shall be set out by the Bidders, clause by Clause in this schedule. Unless specifically mentioned in this Schedule, the tender shall be deemed to confirm the TPCODL/TPNODL/TPSODL/TPWODL 's specifications:</p> <table border="1"> <thead> <tr> <th>S.No.</th> <th>Clause No.</th> <th>Details of deviation with justifications</th> </tr> </thead> <tbody> <tr> <td> </td> <td> </td> <td> </td> </tr> </tbody> </table> <p>We confirm that there are no deviations apart from those detailed above.</p> <p>Seal of the Company:</p> <p style="text-align: right;">Signature Designation</p>	S.No.	Clause No.	Details of deviation with justifications	
S.No.	Clause No.	Details of deviation with justifications				



**Specification No:** ENG-EHV-1021

**Specification Name:** Technical Specification for  
33KV Lightning Arrester (10 KA)

## CONTENTS

1. SCOPE
2. APPLICABLE STANDARDS
3. CLIMATIC CONDITIONS OF THE INSTALLATION
4. GENERAL TECHNICAL REQUIREMENTS
5. GENERAL CONSTRUCTIONS
6. MARKING
7. TESTS
8. TYPE TEST CERTIFICATES
9. PRE-DISPATCH INSPECTION
10. INSPECTION AFTER RECEIPT AT STORES
11. GUARANTEE
12. PACKING
13. TENDER SAMPLE
14. QUALITY CONTROL
15. TESTING FACILITIES
16. MANUFACTURING FACILITIES
17. SPARES, ACCESSORIES AND TOOLS
18. DRAWINGS AND DOCUMENTS
19. TRAINING
20. SCHEDULE "A" GUARANTEED TECHNICAL PARTICULARS
21. SCHEDULE "B" DEVIATIONS

### 1. SCOPE:

This specification covers the design, manufacture, testing and supply of 33kV, 10kA, Station class-SL, (Station class-II) and 33 KV ,10 KA –SM (class –III), Metal Oxide Gap less Polymeric Lightning Arrester. The specific requirements are covered in the enclosed technical data sheet. Some of the parts that may have not been specifically included, but otherwise form part of the Lightning arrester as per standard practice or necessary for proper operation, will be deemed to be also included in this specification. The successful bidder shall not be eligible for any extra charges for such accessories etc. Scope also includes transportation & unloading at store / site.

### 2. APPLICABLE STANDARDS:

The equipment covered by this specification shall unless otherwise stated, be designed, manufactured and tested in accordance with the latest editions of the following Indian, International Standards and shall conform to the regulations of the local authorities:

IEC 60099-4	Specification for surge arrestor without gap for AC System
IS 15086	Specification for Metal Oxide Gap less Lightning arresters for alternating current System
IS 6209	Method of Partial Discharge Measurement
IS 8704 & IS 731	Guide for selection of creepage distance of polymeric housing insulator.
ISO 48	Rubber, vulcanized or thermoplastic -- Determination of hardness (hardness between 10 IRHD and 100 IRHD).
IEC 60721-3-2	Classification of environmental conditions. Classification of groups of environmental parameters and their severities. Transportation
IEC 60071	Insulation co-ordination -- Part 1 definitions, principles and rules; -- Part 2: Application Guide
IEC 60815-1	Selection and dimensioning of high-voltage insulators intended for use in polluted conditions –Part 1: Definitions, information and general principles
IS 2629	Recommended Practice for Hot-Dip Galvanizing of Iron and Steel
IS 2633	Methods for testing uniformity of coating of zinc coated articles
IS 4759	Hot-dip zinc coatings on structural steel and other allied products

### 3. CLIMATIC CONDITIONS:

1	Maximum ambient temperature	50 deg C
2	Max. Daily average ambient temp	35 deg C
3	Min Ambient Temperature	0 deg C
4	Maximum Humidity	95%
5	Average Annual Rainfall	1500mm
6	Average No. of rainy days per annum	120
7	Altitude above MSL not exceeding	1000m
8	Wind Pressure	300 Km/hr
9	Earthquakes of an intensity in horizontal direction	equivalent to seismic acceleration of 0.3g
10	Earthquakes of an intensity in vertical direction	equivalent to seismic acceleration of 0.15g (g being acceleration due to gravity)

TPCODL/TPWODL/TPNODL/TPSODL service area has heavy saline conditions along the coast and High cyclonic Intensity winds with speed upto 300 Kmph. The atmosphere is generally laden with mild acid and dust in suspension during the dry months and is subjected to fog in cold months.

#### 4. GENERAL TECHNICAL REQUIREMENTS:

SL. NO.	TECHNICAL PARTICULARS (Class-SL,Class-II)	DESIRED VALUE
1	Installation	Outdoor
2	Reference standards (Latest Amend.)	IS 15086:Part.4(2017), IEC 60099
3	Arrester Type and Housing	Metal Oxide Gapless Cage type with Polymeric housing
4	Normal System Voltage	33 kV
5	Highest System Voltage	36 kV
6	Rated Frequency	50 Hz
7	Maximum Continuous Operating Voltage (M.C.O.V)	25 kV (rms)
8	Arrester Rating	30 kV (rms)
9	<b>Discharge Current</b>	
a	Nominal Discharge Current	10 kA
b	Switching impulse discharge current	0.5kA

<b>SL. NO.</b>	<b>TECHNICAL PARTICULARS (Class-SL,Class-II)</b>	<b>DESIRED VALUE</b>
10	Short Circuit rating	40 kA
11	<b>Voltage Withstand on Arrester Housing</b>	
a	Standard rated short duration Power Frequency withstand Voltage (Dry/Wet) as per IS:2165	70kV (rms)
b	Standard rated Lightning Impulse withstand Voltage (Peak in kV)	170kV (Peak)
12	Lightning Impulse Protection Level (at 10kA)	115 kV
13	<b>Long Duration Current</b>	
a	Peak Current	400A
b	Virtual duration of Peak T	2000 T (Micro Sec)
14	High Current impulse Operating Duty	100 kA (Peak)
15	Creepage Distance of Arrester Housing	1116 min or 31mm/KV
16	Partial Discharge at 1.05 times M.C.O. V	<10 pc
17	Energy Absorption capacity (KJ/KV)	>=4KJ/KV
18	Repetitive charge transfer withstand (coloumbs), Qrs	>=1.0
19	<b>Temporary over voltage (TOV)</b>	
a	1 sec	51kVp
b	10 sec	49kVp
20	<b>Maximum Lightning Impulse Residual voltage with 8/20 microsecond wave</b>	
a	at 5kA	85kVp
b	at 10kA	90kVp
c	at 20kA	100kVp
21	Maximum switching current impulse residual voltage in kVP at 500 A	73.2 KVP
22	Max. Cantilever Strength	325 kgF
23	Total height of the arrester	To be specified by bidder
24	Total weight of the arrester	To be specified by bidder
25	No. of Metal oxide blocks in arrester	To be specified by bidder
26	Rating of individual ZnO blocks used for assembly	To be specified by bidder
27	Power Losses of the Arrester in watt	To be specified by bidder
28	Type of Mounting	Pedestal
29	Material of Insulating base	UV resistant Fire retardant DMC
30	Insulating Terminal Cap	Polyolefin
31	Material of Nuts and bolts	Stainless Steel

SL. NO.	TECHNICAL PARTICULARS (Class-SM,Class-III)	DESIRED VALUE
1	Installation	Outdoor
2	Reference standards (Latest Amend.)	IS 15086:Part.4(2017), IEC 60099
3	Arrester Type and Housing	Metal Oxide Gapless Cage type and Polymeric housing
4	Normal System Voltage	33 kV
5	Highest System Voltage	36 kV
6	Rated Frequency	50 Hz
7	Maximum Continuous Operating Voltage (M.C.O.V)	25 kV (rms)
8	Arrester Rating	30 kV (rms)
9	<b>Discharge Current</b>	
a	Nominal Discharge Current	10 kA
b	Switching impulse discharge current	1kA
10	<b>Short Circuit rating</b>	40 KA
a	Reduced Short circuit currents	25 kA
b	Low short circuit current with a duration of 1 sec	600±200 kA
c	Prospective symmetrical fault current	40 kA for min 0.2 sec
11	<b>Voltage Withstand on Arrester Housing</b>	
a	Standard rated short duration Power Frequency withstand Voltage (Dry/Wet) as per IS:2165	70kV (rms)
b	Standard rated Lightning Impulse withstand Voltage (Peak in kV)	170kV (Peak)
12	Lightning Impulse Protection Level (at 10kA)	115 kV
13	<b>Long Duration Current</b>	To be provided by bidder
a	Peak Current	To be provided by bidder
b	Virtual duration of Peak T	2400 T (Micro Sec)
14	High Current impulse Operating Duty	100 kA (Peak)
15	Creepage Distance of Arrester Housing	1116 min or 31mm/KV
16	Partial Discharge at 1.05 times M.C.O. V	<10 pc
17	Energy Absorption capacity (KJ/KV)	>=7KJ/KV
18	Repetitive charge transfer withstand (coloumbs),Qrs	1.6 Coloumbs
19	<b>Temporary over voltage (TOV)</b>	
a	1 sec	51kVp
b	10 sec	49kVp
20	<b>Maximum Lightning Impulse Residual voltage with 8/20 microsecond wave</b>	
a	at 5kA	85kVp
b	at 10kA	90kVp

SL. NO.	TECHNICAL PARTICULARS (Class-SM,Class-III)	DESIRED VALUE
c	at 20kA	100kVp
21	<b>Maximum switching current impulse residual voltage in kVP At 500 Amps</b>	73.2KVp
22	Max. Cantilever Strength	325 kgF
23	Total height of the arrester	To be specified by bidder
24	Total weight of the arrester	To be specified by bidder
25	No. of Metal oxide blocks in arrester	To be specified by bidder
26	Rating of individual ZnO blocks used for assembly	To be specified by bidder
27	Power Losses of the Arrester in watt	To be specified by bidder
28	Type of Mounting	Pedestal
29	Material of Insulating base	UV resistant Fire retardant DMC
30	Insulating Terminal Cap	Polyolefin
31	Material of Nuts and bolts	Stainless Steel

## 5. GENERAL CONSTRUCTION:

### 5.1 Assembly:

The surge arresters shall conform in general to IEC-60099-4 ed 3.0

Surge arrester shall be supplied along with the insulating base, terminal connector, insulating terminal cap (Polyolefin) and necessary hardware. The Assembly consists of a stack of Metal Oxide elements arranged in a cage type design. All metal parts shall be of non-rusting and non corroding metal (All ferrous parts shall be Hot Dip Galvanized i.e. HDG). All nuts & bolts shall be with double spring washers. Bolts, screws and pins shall be provided with lock washers. Surge arrester construction shall be suitable to withstand Seismic Loading, Short Circuit Forces and wind load and the force exerted on the arrester base and to the terminal imposed by the line conductor. All similar parts, particularly removable ones, shall be interchangeable.

Arresters shall be completely molded units with absolutely no air volume inside.

Arresters of tubular construction i.e arresters assembled in hollow core insulators with enclosed gas volume are not acceptable due to abrupt short circuit performance and poor sealing mechanism.

- a) Housing shall be polymeric to provide thermal dissipation of heat generated in the metal oxide elements during over voltage and line discharge. Polymeric housing shall be free from flaws affecting the mechanical and electrical strength of the arrester. Housing shall be capable to withstand the desired pollution stresses without flashover. Housing shall be capable to



withstand the temperature rise due to the non uniform field distribution, caused by the pollution on the surface of the housing. The rain sheds / petticoats shall be of polymeric material and shall confirm to IEC 60815.

- b) The arrester shall have thermal stability to withstand the heat generated from ZnO element due to continuous operating voltages and surges. It shall remain in undamaged condition, capable protective function.
- c) Arrestors shall incorporate anticontamination feature to prevent arrester failure, consequent to uneven voltage gradient across the stack in the event of contamination of the arrester insulating material. These features shall be described in detail when submitting the Bid. Arrestors shall be capable of discharging over voltages occurring during switching of unloaded transformers, capacitors banks and long lines. No radio interferences shall be caused by the arrestors operating at the normal rated voltage.
- d) MO resistor diameter shall be mentioned by the bidder at the time of bidding along with its rating . MOV blocks shall have full metallization to have full face contact and to reduce contact resistance between adjacent discs.
- e) Surge arresters shall be of cage type construction with no gas volume to ensure that the arrester does not explode during the short circuit test condition. The MOV blocks should be housed in cage of FRP rods appropriately crimped at both end fittings. The housing should be directly molded on stack of MOV blocks without any intermediate interface.
- f) The end fittings shall be non-magnetic and of corrosion proof material. The end fittings used in polymer arrester shall be made from aluminum through machining process/pressure die-casting process. Sand casted and gravity casted end fittings are not acceptable due to poor microstructure and porosity issues.

## 5.2 EARTHING PADS:

Suitable earthing pads shall be provided in the lightning arrester and surge counter for earthing.

## 5.3 MECHANICAL STRENGTH:

- a) The Lightning Arrester and its base shall withstand rated mechanical terminal load and electromagnetic forces without impairing their operational reliability.
- b) The Lightning Arrester shall not come out of their positions by gravity, wind pressure, vibrations or reasonable shocks.

## 5.4 SURGE COUNTER :

- a) Cyclometric 5 digit, non-resetting type counter, dial type surge counter shall be provided for each lightning arrester for automatically recording the number of discharges. Each counter shall have a continuous leakage current indicator and shall not require an external power source of

operation. The value of leakage current beyond which the operation is abnormal shall be clearly marked in red colour on the detector.

- b) Surge arrestor shall include a milli ammeter to monitor the leakage current. the milli –ammeter usually bare a red mark at the higher scale regions. Increase of leakage current to the red marked zone is essentially an indication that the arrestor is likely to attain the thermal runaway condition. The qualitative information regarding the arrestor the arrestor health, obtained from the milli-ammeter, helps the user to take preventive measures before the arrestor failure.
- c) Discharge counters and milli-ammeters shall be suitable for mounting on structure and shall be mounted at approximately 1.5 meters above ground level. The reading of the milli-ammeter and counters shall be visible through an inspection glass panel. The terminals shall be of robust and adequate size and shall be so located that incoming and outgoing connections are made with minimum possible bends.
- d) The connecting conductor from lightning arrester earth terminal to the discharge counter incoming terminal shall be insulated for a minimum of 1.1 kV and this insulated conductor shall be supplied along with the arrester by the bidder. The surge arrester surge counter connection shall be done by means insulated multi strand copper cable of minimum size 35 sq.mm to withstand the fault currents during severe operating conditions. Length of the each cable should be considered as 3.5 mtr (min.). This copper cable shall be of black color and shall have fire retardant & UV resistance properties. Approved Make for this Cable is Polycab/KEI/KEC/Sterlite/Finolex/Havells. The cable shall have copper lugs at both ends. Bimetallic strips must be provided along with Surge Counter for bimetallic connections.
- e) The surge arrester shall be designed to operate/ withstand without damage or change in performance for the high current impulse, long duration current impulse corresponding to the discharge class of the surge arrester and nominal discharged current corresponding to the discharge current of the surge with which it is used.
- f) The external and internal parts of the surge monitor shall be hermetically sealed to withstand the atmospheric variation of temperature and humidity, rain and dust encountered in station in which they are installed. RTV silicon sealant to be used. The surge Monitor line terminal shall be solidly connected to the ground terminal of the surge monitor through an inbuilt metal oxide element satisfying the operational requirement.

#### **5.5 CONNECTORS:**

Aluminum terminal to be provided for Surge Arrestor. This terminal shall be connected via Standard bolted type connector (L-Shaped) connector with the network equipment via AAAC Panther Conductor. Therefore terminal connector shall be part of Surge Arrestor.



**Specification No:** ENG-EHV-1021

**Specification Name:** Technical Specification for  
33KV Lightning Arrester (10 KA)

## 6. MARKING:

A stainless steel rating plate, of at least 1 mm thickness, shall be fitted to each Lightning Arrester in a visible position and shall carry all the information as specified in the standards. The letters on the rating plate shall be engraved black on the white/silver background. Fixing screws for outdoor use shall be of stainless steel or any other corrosion resistant metals. The Name plate shall be embossed with "PO no. with date" & "TPCODL/TPWODL/TPNODL/TPSODL",

The following information shall be mentioned on the Name Plate

- a) Continuous operating Voltage
- b) Rated Voltage
- c) Rated Frequency
- d) Nominal Discharge Current
- e) Pressure relief rated current in kA r.m.s.
- f) Manufacturer's Name
- g) Type and Identification of the complete
- h) Year/Month of Manufacture
- i) Serial Number.
- j) Warrantee/guarantee clause

## 7. TESTS:

All routine, acceptance & type tests shall be carried out in accordance with the relevant IS/IEC. All acceptance tests shall be witnessed by the purchaser/his authorized representative. All the components and fittings shall also be type tested as per the relevant standards. Following tests shall necessarily be conducted on lightning arrester in addition to others specified in IS/IEC standards: -

### 7.1 ACCEPTANCE TESTS

Acceptance test shall be as per cl. 9.2 of IEC 60099-4 ed 3 as mentioned below:

- a) Measurement of reference voltage test.
- b) Residual Voltage test on complete arrester.
- c) Partial Discharge Test
- d) Visual Inspection
- e) The resistive current drawn by the arrester at rated voltage
- f) Peel off test (removal of housing) shall be performed on 1 random samples from supplied lot to confirm cage design
- g) Measurement of power-frequency voltage on the arrester at the reference current
- h) Lightning impulse residual voltage on the arrester at nominal discharge current ( wet power frequency voltage test)

All acceptance tests shall be witnessed by the Purchaser's or his authorized



**Specification No:** ENG-EHV-1021

**Specification Name:** Technical Specification for 33KV Lightning Arrester (10 KA)

representative. The above mentioned test shall be made on the nearest lower whole number to the cube root of the number of arresters to be supplied as per IEC-60099-4.

## 7.2 ROUTINE TESTS

Routine test shall be as per cl. 9.1 of IEC 60099-4 ed 3 as mentioned below:

- a) Measurement of reference voltage test
- b) Residual Voltage Test on complete arrester
- c) Internal partial discharge test.
- d) The resistive current drawn by the arrester at rated voltage
- e) The power-frequency voltage

## 7.3 TYPE TESTS

- a) Insulation Withstand Test of Housing ( Lightning impulse – (cl. 8.2.8; IEC 60099-4 ed.3))
- b) Residual voltage test (cl. 8.3.2, cl. 8.3.3., cl 8.3.4; IEC 60099-4 ed.3)
- c) Long duration current impulse withstand test (cl. 8.4; IEC 60099-4 ed.3)
- d) Operating duty test (cl. 8.7; IEC 60099-4 ed.3)
- e) Short circuit test (Low (600A)/High Current (40kA) (cl. 8.10; IEC 60099-4 ed.3)
- f) Test for Bending moments (cl. 8.11; IEC 60099-4 ed.3)
- g) Weather aging test on full arrester 1000 hrs (cl. 8.12 and annexure-C; IEC 60099-4 ed.3)
- h) Partial Discharge Test (cl. 8.15; IEC 60099-4 ed.3)
- i) Wet power frequency voltage test (cl. 8.2.8; IEC 60099-4 ed.3)
- j) Power frequency (voltage VS time curve) (cl. 8.8; IEC 60099-4 ed.3)
- k) Test to verify repetitive charge transfer withstand (cl. 8.5; IEC 60099-4 ed.3)
- l) Heat Dissipation behavior verification of test sample (cl. 8.6; IEC 60099-4 ed.3)

## 8. TYPE TEST CERTIFICATES:

The Bidder shall furnish the type test certificates for the tests as mentioned above as per the corresponding standards. All the tests shall be conducted at **CPRI/ERDA** as per relevant standard. Type tests should have been conducted during the period not exceeding **5** years from the date of opening the bid. In the event of any discrepancy in the test reports, i.e. any test report not acceptable, same shall be carried out without any cost implication to TPCODL/TPWODL/TPNODL/TPSODL.

## 9. PRE-DISPATCH INSPECTION:

The material shall be subject to inspection by a duly authorized representative of the TPCODL/TPWODL/TPNODL/TPSODL. Inspection may be made at any stage of manufacture at the discretion of the purchaser and the equipment, if found unsatisfactory as to workmanship or material, the same is liable to rejection. Bidder shall grant free access to the places of manufacture to TPCODL/TPWODL/TPNODL/TPSODL's representatives at all times when the work is in progress. Inspection by the TPCODL/TPWODL/TPNODL/TPSODL or its authorized



**Specification No:** ENG-EHV-1021

**Specification Name:** Technical Specification for 33KV Lightning Arrester (10 KA)

representatives shall not relieve the bidder of his obligation of furnishing equipment in accordance with the specifications. Material shall be dispatched after specific MDCC (Material Dispatch Clearance Certificate) is issued by TPCODL/TPWODL/TPNODL/TPSODL.

Following documents shall be sent along with material.

- a) Test reports
- b) MDCC issued by TPCODL/TPWODL/TPNODL/TPSODL
- c) TPCODL/TPWODL/TPNODL/TPSODL Invoice in duplicate
- d) Packing list
- e) Drawings & catalogue
- f) Guarantee / Warrantee card
- g) Delivery Challan
- h) Other Documents (as applicable).

#### **10. INSPECTION AFTER RECEIPT AT STORE:**

The material received at TPCODL/TPWODL/TPNODL/TPSODL, Odisha store will be inspected for acceptance and shall be liable for rejection, if found different from the reports of the pre-dispatch inspection and one copy of the report shall be sent to Engineering department.

#### **11. GUARANTEE:**

Bidder shall stand guarantee towards design, materials, workmanship & quality of process/manufacturing of items under the contract for due and intended performance of the same, as an integrated product delivered under this contract. In the event any defect is found by the Company up to a period of 18 months from the date of commissioning or 24 months from the date of last supplies made under the contract, whichever is earlier, supplier shall be liable to undertake to replace/rectify such defects at his own costs. within mutually agreed timeframe, and to the entire satisfaction of the Company, failing which the Company will be at liberty to get it replaced/rectified at supplier's risks and costs and recover all such expenses plus the Company's own charges (@ 20% of expenses incurred), from the supplier or from the "Security cum Performance Deposit" as the case may be.

The bidder shall further be responsible for ' free replacement' for another period of THREE years from the end of gurantee period for any 'latent defects' if noticed by the company.

#### **12. PACKING AND TRANSPORT:**

Bidder shall ensure that all material covered by this specification shall be prepared for rail/road transport (local equipment) and be packed in such a manner as to protect it from damage in transit. The bidder shall provide instructions regarding handling and storage precautions to be taken at



**Specification No:** ENG-EHV-1021

**Specification Name:** Technical Specification for 33KV Lightning Arrester (10 KA)

site. The material should be packed in vertical position in individual box in such a way that the shape of rain shed does not get deformed during transportation and storage.

**13. TENDER SAMPLE:**

NA

**14. QUALITY CONTROL:**

The bidder shall submit QAP indicating the various stages of inspection, the tests and checks which will be carried out on the material of construction, components during manufacture and bought out items and fully assembled component and equipment after finishing. As part of the plan, a schedule for stage and final inspection within the parameters of the delivery schedule shall be furnished. The Purchaser's engineer or its nominated representative shall have free access to the manufacturer's/sub-supplier's works to carry out inspections.

**15. TESTING FACILITIES:**

Bidder shall have adequate in house testing facilities for carrying out all routine tests & acceptance tests as per relevant International / Indian standards.

**16. MANUFACTURING FACILITIES:**

The successful bidder shall submit the bar chart for various manufacturing activities clearly elaborating each stage, with quantity. This bar chart should be in line with the Quality assurance plan submitted with the offer.

The successful bidder will have to submit technical compliance document and drawing as per RC line items for getting approval before mass manufacturing.

Manufacturing shall start only after getting CAT-B approved drawings or as per intimation from TPCODL/TPWODL/TPNODL/TPSODL.

**17. SPARES, ACCESSORIES AND TOOLS**

Spares:Not applicable.

**Service Level Agreement**

- In case of any failure vendor shall report to site, within 24 hours of receipt of reporting of failure occurrence.
- Vendor shall provide detailed root cause analysis of the fault within 15 days from the date of occurrence of the fault/ failure.
- Any spare part replacement, testing and its commissioning to be done by the vendor only, without any price implication to the purchaser.

**18. DRAWINGS AND DOCUMENTS:**

Following drawings and documents shall be prepared based on





**Specification No:** ENG-EHV-1021

**Specification Name:** Technical Specification for 33KV Lightning Arrester (10 KA)

TPCODL/TPWODL/TPNODL/TPSODL specifications and statutory requirements and shall be submitted with the bid:

- a) Completely filled in Technical Particulars
- b) General description of the equipment and all components including brochures
- c) General arrangement drawing for Surge Arrestor (SA)
- d) Bill of material
- e) Experience List
- f) Type test certificates

**Drawings / documents to be submitted after the award of the contract are as under:**

**List of Drawings/Parameters to be submitted:**

S.No.	Description	For Approval	For Review Information	For Final Submission
1	Technical Particulars	✓	✓	✓
2	General Arrangement drawings including cross sectional view, mounting arrangement, Zno Block drawing, Surge Counter drawing, Name plate along with detailed Bill of Material)	✓	✓	✓
3	Terminal and Connection Drawing	✓	✓	✓
4	Manual/catalogue	✓	✓	✓
5	Installation/Commissioning Manuals	✓	✓	✓
6	Instruction for use	✓	✓	✓
7	Transport / Shipping dimension drawing	✓	✓	✓
8	QA & QC Plan	✓	✓	✓
9	Routine, Acceptance and Type Test Certificates	✓	✓	✓

**Additional Documents to be submitted:**

- a) List of raw materials as well as bought out accessories and the names of sub-suppliers selected from those furnished along with offer.
- b) Type test certificates of the raw materials and bought out accessories.
- c) The successful Bidder shall submit the routine test certificates of bought out accessories and central excise passes for raw material at the time of routine testing.

All the documents & drawings shall be in English language.

After the receipt of the order, the successful bidder will be required to furnish all relevant drawings/parameters/calculation to TPCODL/TPWODL/TPNODL/TPSODL for approval.

**Instruction Manuals:**





Bidder shall furnish softcopies of nicely bound manuals (In English language) covering erection and maintenance instructions and all relevant information and drawings

pertaining to the main equipment as well as auxiliary devices.

**19. SCHEDULE- "A" GUARANTEED TECHNICAL PARTICULARS:**

GENERAL TECHNICAL PARTICULARS			
SL. NO.	TECHNICAL PARTICULARS	SM Class (Class-III)	SL Class (Class-II)
1	Installation		
2	Reference standards (Latest Amend.)		
3	Arrester Type and Housing		
4	Normal System Voltage		
5	Highest System Voltage		
6	Rated Frequency		
7	Maximum Continuous Operating Voltage (M.C.O.V)		
8	Arrester Rating		
9	<b>Discharge Current</b>		
a	Nominal Discharge Current		
b	Switching impulse discharge current		
10	Short Circuit rating		
11	<b>Voltage Withstand on Arrester Housing</b>		
a	Standard rated short duration Power Frequency withstand Voltage (Dry/Wet) as per IS:2165		
b	Standard rated Lightning Impulse withstand Voltage (Peak in kV)		
12	Lightning Impulse Protection Level (at 10kA)		
13	<b>Long Duration Current</b>		
a	Peak Current		
b	Virtual duration of Peak T		
14	High Current impulse Operating Duty		
15	Creepage Distance of Arrester Housing		
16	Partial Discharge at 1.05 times M.C.O. V		
17	Energy Absorption capacity (KJ/KV)		
18	Repetitive charge transfer withstand (coloumbs),Qrs		
19	<b>Temporary over voltage (TOV)</b>		
a	1 sec		
b	10 sec		
20	<b>Maximum Lightning Impulse Residual voltage with 8/20 microsecond wave</b>		



   	<b>Specification No:</b> ENG-EHV-1021  <b>Specification Name:</b> Technical Specification for 33KV Lightning Arrester (10 KA)
--	---

a	at 5kA		
b	at 10kA		
c	at 20kA		
21	Maximum switching current impulse residual voltage in kVP at 500 A		
22	Max. Cantilever Strength		
23	Total height of the arrester		
24	Total weight of the arrester		
25	No. of Metal oxide blocks in arrester		
26	Rating of individual ZnO blocks used for assembly		
27	Power Losses of the Arrester in watt		
28	Type of Mounting		
29	Material of Insulating base		
30	Insulating Terminal Cap	Polyolefin	
31	Material of Nuts and bolts	Stainless Steel	

**20. SCHEDULE "B" DEVIATIONS:**

**(TO BE ENCLOSED WITH TECHNICAL BID)**

All deviations from this specification shall be set out by the Bidders, clause by Clause in this schedule. Unless specifically mentioned in this Schedule, the tender shall be deemed to confirm the purchaser's specifications:

SL. No	Clause No.	Details of deviation with justifications

We confirm that there are no deviations apart from those detailed above.

Seal of the Company:

Signature

Designation

## TECHNICAL SPECIFICATION

Designing, Supply & Installation of Transmission Line towers ( PC+6 / UR+6) for River bed

## TECHNICAL SPECIFICATION

### PART- I

## Design, Supply & Erection of Tower along with all fabrication & civil related work

### 1.0 SCOPE

The Bidder has to design, supply & erect the tower as per wind zone -V with sustaining wind speed up to 300Kmph .The Bidder will carry out the necessary site visit & will assess the span length, soil investigation, Tower position afterward will submit the necessary engineering calculation for selection of suitable Tower type & civil foundation design to TPCODL team for approval before installation.Each river crossing shall be crossed with 2No's of STRUCTURE

- A) It has been proposed bidder shall supply & install PC +6 (D type tower) along with 14Mtr DP arrangement for 33KV line span length UP TO 300Mtr.
- B) It has been proposed bidder shall supply & install UR +6 (D type tower) along with 14Mtr DP arrangement for 33KV line span length >300Mtr UP TO 550Mtr.

Both the towers will be designed to carry double circuit line with conductor size 232sqmm. Both the towers are proposed to be installed on both side of river .Bidder will do the necessary arrangement for transporting of these tower from factory to site, will carry out the necessary civil work for installation of Tower. Bidder will also arrange necessary ROW permission at his own Cost.

Firms shall quote their rates for their own design of towers as well as the TPCODL design towers as per the enclosed schedule. The tower design shall be for 220 Multi circuit tower with Special type Towers of UR and its extensions & similarly for PC+6 type tower it shall be designed for 132KV multi circuit tower, for which TPCODL shall provide bill of materials and out line drawings.

2.1.1 This specification also provides relevant data for design, proto fabrication, galvanizing and delivery FOR (destination) of transmission line towers including super-structure stubs, tower extensions, stub-templates, tower accessories (Hangers, U-bolts, bird guards, anti-climbing devices), bolts and nuts, step bolts, flat and spring washers etc. for utilization in TPCODL's transmission network. General: Preliminary route alignment in respect of the proposed transmission lines has been fixed by the employer (**TPCODL**) subject to alteration of places due to way leave or other unavoidable constraints. The Right of way shall be solved by the contractor and all expenses there of shall be borne by him. However, **TPCODL** shall render all helps in co- ordination with law and order department for solving the same. Statutory clearance if any shall be arranged by **Vendor**.

2.1.2 Provisional quantities/numbers of different types of towers have been estimated and indicated in the BOQ Schedule given. However final quantities for work shall be as determined by the contractor, on completion of the detail survey, preparation of route profile drawing and designing of the appropriate types of towers as elaborated sin the specification and scope of work.

2.1.2.1 The contractor shall undertake detailed survey on the basis of the tentative alignment fixed by the employer. The said preliminary alignment may, however, change in the interest of economy to avoid forest and hazards in work. While surveying the alternative route the following points shall be taken care by the contractor.

- (a) The line is as near as possible to the available roads in the area.
- (b) The route is straight and short as far as possible.
- (c) Good farming areas, religious places, forest, civil and defence installations, aerodromes, public and private premises, ponds, tanks, lakes, gardens, and plantations are avoided as far as practicable.
- (d) The line is far away from telecommunication lines as reasonably possible. Parallelism with these lines shall be avoided as far as practicable.
- (e) Crossing with permanent objects are minimum but where unavoidable preferably at right angles.
- (f) Difficult and unsafe approaches are avoided.
- (g) The survey shall be conducted along the approved alignment only in accordance with IS: 5613 (Part-II/Section-2), 1985.
- (h) For river crossing/ Crossing of Nallas: Taking levels at 20 metre interval on bank of river and at 40 metre interval at bed of river so far as to show the true profile of the ground and river bed. The levels may be taken with respect to the nearest existing towers, pile foundation of towers, base or railway/road bridge, road culvert etc. The levels shall be taken at least 100 m. on either side of the crossing alignment. Both longitudinal and cross sectional shall be drawn preferably to a scale of 1:2000 at horizontal and 1:200 vertical.

After completing the detailed survey, the contractor shall submit the final profile and tower schedule for final approval of the employer. The final profile and tower schedule shall incorporate position of appropriate type of towers. To facilitate checking of the alignment, suitable reference marks shall be provided. For this purpose, concrete pillars of suitable sizes shall be planted at all angle locations and suitable wooden/iron pegs shall be driven firmly at the intermediate points. The contractor shall quote the rate covering all the scope including supply of material, Survey, Soil profiling, Installation & testing required for the project.

Only approved sag template shall be used for tower spotting and the final profiles by the contractor.

#### 2.1.2.2 PROFILE PLOTTING AND TOWER SPOTTING

The profile shall be plotted and prepared to the scale 1 in 2,000 for horizontal and 1 in 200 for vertical on squared (mm) paper. If somewhere the difference in levels be too high, the chart may be broken up according to the requirements. A 10 mm overlap shall be shown on each following sheet. The chart shall progress from left to right for convenience in handling. The sheet size may be conveniently chosen.

With the help of sag template, final tower location shall be marked on the profiles and while locating the tower on survey chart, the following shall be kept in mind:

[ The contractor shall also submit the land schedule on revenue (if required) maps indicating alignment therein duly authenticated by Revenue Inspector & Tahasildar, enumeration of trees with the help of Forest officer and other prominent features required for alignment of the proposed line. Final route to be plotted on 1:50000 topo sheet for approval. Detail GIS (Geographical Information System) of towers to be included.]

- (a) The number of consecutive span between the section points shall not exceed 10 in case of straight run on a more or less plain stretch.
- (b) Individual span shall be as near as to the normal design ruling span.

In different crossing the contractor shall take into consideration the prevailing regulations of the respective authorities before finalizing type and location of the towers. While carrying out survey work, the contractor has to collect all relevant data, prepare and submit drawings in requisite number for obtaining clearance from the PTCC, road, aviation, railways, river and forest authorities.

The contractor shall remain fully responsible for the exact alignment of the line. If after erection, any tower is found to be out of alignment, the same shall have to be dismantled and re-erected after correction by the contractor at his own cost, risk and responsibility, including installation of fresh foundation, if belt necessary by the employer.

After peg marking of the angle tower or tension towers, the contractor shall obtain approval from the employer and thereafter pegging of suspension type tower shall be done by the contractor and pegging of all the four legs of each type of towers at all the locations shall be done.

**a) Wind effects:**

Tower shall be designed for reliability Level-I, Terrain category-I & Wind Zone-V Design wind pressure on towers, conductors, earth wire and insulator string in the range of 30.45 mt. And above 45 mt. Height shall be computed as per IS-802(Part/Sec-I) 1995 Bidder shall furnish the maximum wind pressure adopted in their design against each component mentioned above.

**b) Design Temperatures:**

The following temperature range for the power conductor and ground wires shall be adopted for the line design:

(i)	Minimum temperature:	5 deg. C
(ii)	Everyday temperature of conductor	32 deg. C
(iii)	Maximum temperature of Conductor	
1.	75 deg. C for ACSR/Zebra/Panther	90 deg. C for AAAC Moose.
2.	Ground wire exposed to sun	53 deg. C

The above values are subject to latest revision if any made in IS-802 (part-I/Sec-I) 1995

**c) Maximum Tension:**

Maximum tension shall be based on either:

i)	at 5 deg. C with 2/3 <sup>rd</sup> . full wind pressure	or Conform to IS 802-1995
ii)	At 32 deg. C with full wind pressure whichever is more stringent.	Part-I/Sec-I-Clause No.10.3

**d) Factors of Safety & Span details:**

i)	Factor of Safety	Should conform to IS-802 Part-I-1995
ii)	Normal span:	The normal span of the line shall be 350 meters of 220KV and 320 meters for 132 KV.
iii)	Wind & Weight Span	The wind and weight span to be adopted in the design of the structures shall be as follows
iv)	Wind span:	The wind span is the sum of the two half spans adjacent to the support under consideration. In case of towers located on a perfectly horizontal terrain, this shall be the normal span. For design purpose the wind on conductor shall be calculated on a wind span of at least 1.1 times the normal span
v)	Weight Span	The weight span is the horizontal distance between the lowest point of the conductors on the two spans adjacent to the tower. All C and D type towers shall be designed for uplift spans (minimum weight spans in the following table) also. These are applicable both for pointed and square cross arms.

For details of cross arms and towers, the span limits given below shall prevail.

Tower type.	220 KV				132 KV			
	Normal condition.		Broken wire condition.		Normal condition.		Broken wire condition.	
	Max.	Min.	Max.	Min.	Max.	Min.	Max.	Min.
A/DA & B/DB	525	100	315	100	500	100	300	100
C/DC & D/DD	600	100	360	100	500	100	300	100

1.2 The design of towers and their extensions shall be done conforming to the design parameters specified herein, the scope of design also includes supply of design calculation for towers and extensions including detailed structural/shop drawings of towers extensions and stub setting templates. The bidder, who has already type tested the various tower viz: 0-2°, +3, +6; 0-15°, +3, +6; 0-30°, +3, +6; 0-60°, +3, +6 ( 220 KV) in any nationally or internationally recognized laboratories, and conforming to our specification, may also offer the same.

**1.3 Standards:**

Except as modified in this specification, the material and work covered under this specification shall conform to the latest revision with amendments thereof of the following of Indian Standards and equivalent International Standards whenever indicated below.

Sl No	Bureau of Indian standards (BIS)	Title	International & Internationally recognized standard
1	IS:209	Specification for Zinc	ISO/R/752

2	IS: 2062	Structural steel (Standard quality)	ISO/R/660
3	IS: 432	Mild steel and medium tensile bars and for concrete reinforcement	BS-785CSA-G-30
4	IS: 802	Code of practice for use of structural steel in overhead transmission line Part-I/Section-I & Section2: Load and permissible stresses Part-II: Fabrication Galvanizing Inspection and Packing	
		<b>PART-III: TESTING</b>	
5	IS: 136	Technical supply conditions for threaded fasteners	
6	IS: 1893	Criteria of Earthquake resistant design structures	
7	IS: 2016	Plain washers	ISO/R/987
8	IS: 2551	Danger Notice Plates	
9	IS: 2629	Recommended practice for hot dip galvanizing of iron and steel	
10	IS: 2633	Method of testing uniformity of casting of zinc coated articles	
11	IS: 3063	Single coil rectangular section spring washers for bolts, bolts, screws	DIN-127
12	IS: 5358	Hot dip galvanized coatings on Fasteners	
13	IS:5613 Part-1 & 2 Of Section-I	Code of Practices for design installation & maintenance of, overhead power line	
14	IS: 6610	Specification for heavy washers for steel structures	
15	IS: 6745	Methods of determination of weight of zinc coating of zinc coated iron and steel articles	

#### 1.4 The standards mentioned above are available from

Reference/ Abbreviation	Name and Address from which the Standards are available
IS	BUREAU OF INDIAN STANDARDS Manak Bhavan, 9, Bahadur Shah Zafar Marg, NEW DELHI(India)
ISO	INTERNATIONAL ORGANISATION FOR STANDARDISATION, Danish Board Standardisation, Danish Standardising Street, Aurehoegbvej-12, DK-2900, Hellestrup, DENMARK
CSA	CANADIAN STANDARD ASSOCIATION 178, Rexdale Boulevard, Rexdale, Ontario, CANADA M9W 1R7
BS	BRITISH STANDARDS British Standard Institution, 101, Pentonville Road, N-19-ND-UK
DIN	DEUTSCHES INSTITUT FÜR NORMUNG Gurggrafenstrasse 5-10, Post Fach 1107 D-1000, Berlin - 30

Indian Electricity Rules 1956, Regulation for Electrical crossing of Railway tracks.	KITAB MAHAL , Baba Kharak Singh Marg, NEW DELHI - 110 001(INDIA)
--	--

## 2.0 PRINCIPAL PARAMETERS

### 2.1 Electrical System Data:

a)	System voltage (kV rms)	220	132
b)	Max. voltage (kV rms)	245	145
c)	Lightning impulse withstand voltage (dry & wet) (kVp)	1050 to 1250	650 to 750
d)	One min. Power frequency withstand voltage (wet) (KV rms)	460	275
e)	Short circuit level (KA for 1 sec.)	40	31.5

### 2.2 Line data

#### 2.2.1 Conductor

a)	Name	ACSR Zebra	AAAC Moose
b)	Strength & wire dia		
i)	Aluminium	54/3.18	61/3.55
ii)	Steel	7/3.18	---
c)	Conductors per	Single	Single
d)	Spacing between the conductors of same phase (sub-conductor spacing) (mm)	----	-----
e)	Inter-phase spacing (mm)	8,400	8,400
f)	Configuration		
i)	Single circuit	Delta	Delta
ii)	Double circuit	Vertical	Vertical
g)	Nominal Aluminium area (mm <sup>2</sup> )	420	520(Alu. Alloy)
h)	Section area of Aluminium (mm <sup>2</sup> )	428.90	603.7 (Alu. Alloy)
i)	Total sectional area (mm <sup>2</sup> )	484.50	603.7
j)	Calculated resistance at 200 c (Max.) ohm/km per conductor	0.06915	0.05502
k)	Approx. calculated breaking load (KN)	130.32	159.8
l)	Modulus of elasticity (GN/M <sup>2</sup> )	69	54
m)	Co-efficient of linear exp. Per degree cent.	19.3X10	23X10
n)	Mass of zinc in gms/sqm		
o)	Overall diameter (mm)	28.62	31.95
p)	Weight (kg/km)	1621	1666
q)	Minimum ultimate tensile strength (KN)	130.32	159.8
r)	Conductor tension at 32° C without external load		
i)	Initial unloaded tension		
ii)	Final unloaded tension		

#### 2.2.2 Galvanized Steel Ground Wire

a)	Size (no. of strands/strand dia)	.....7/3.15.....
----	----------------------------------	------------------



b)	Overall diameter (mm)	.....9.45.....
c)	Standard weight (Kg/km)	.....432.....
d)	Location of ground wire	One continuous ground wire to run horizontally on the top of the towers.
e)	Tensile load in each ground wire	
i)	At min. temp. of 5° C and in still air (kgs)	
ii)	At every day temp. of 32° C and still air (kgs)	
iii)	At 5° C and 2/3 <sup>rd</sup> of full wind (kgs)	

### 2.2.2.1 Towers

a)	Span lengths in meters	220 KV ACSR Zebra/Moose	220 KV AAAC Zebra	132 KV ACSR Panthor	132 KV AAAC panthor
i)	Ruling design span	300,335,350,375	300,335,350	300,315,325, 335	300,315,325
b)	Wind load (kg/sqm) on conductor	52	52	52	52
c)	Shielding angle with vertical	20°	20°	20°	20°
d)	Towers to be designed for heavy wind zone				

### 2.2.2.2 Insulator Strings

Sl. No.	Particulars	Single Suspension string/ Single Tension string/	Double suspension string/ Double Tension string	Single Suspension string/ Single Tension string	Double suspension string/ Double Tension string
1.	No. of standard Discs (Nos) (220kV)	1X14/1X15	2X14/2X15	1X10/1X11	2X10/2X11
2.	Size of Disc	280	280	305	305
3.	Electromechanical strength (kg)	90/120 KN	90/120 KN	90/160 KN	90/160 KN

The towers should be also designed for Double circuit both for ACSR and AAAC Zebra for 220 KV and Double circuit ACSR and AAAC Panther for 132KV System of TPCODL .All the towers should be suitable for Double circuit. However, the tower should be designed in such a way that in case of single Circuit stringing, there should not be any unbalance. The towers should also be designed taking into consideration of other type of earth wires, insulators of highest tensile strength.

## 2.0 GENERAL TECHNICAL REQUIREMENTS

### 2.1 Tower Design – General

The employer is looking for a structurally safe design of transmission line towers to be installed on EHV lines keeping the loadings and line parameters detailed in this specification and in compliance with IS: 802 (Part-1/Sec-1)-1995, IS: 802(Part-1/Sec-2)-1992.

The Bidder may offer economical designs with rational sections or offer towers of recent design, proven in service and accepted by other reputed Central and State Sector Utilities and by TPCODL (Previously ODISHA POWER TRANSMISSION CORPORATION) confirming to this technical specification. The Bidder in the latter case shall forward documentation

of proto type tests conducted and acceptance given by the user authorities as also performance report for such towers in service.

## 2.2 Transmission Towers

**2.2.1 General Description:** The towers shall be of the following types.

- (a) Double Circuit (A, B& C) and their extensions of +3 mtr,+6 mtr,+9 mts,+15mtrs and +24mtrs
- (b) Double Circuit (A, B, C & D) and their extensions of +3 mtr,+6 mtr,+9 mts,+15mtrs and +24mtrs
- (c)Special Towers (River Crossing, Railway Track Crossing, Power Line Crossing etc.)
- (d) Multi circuit Towers for 220 KV System

**2.2.2** The towers shall be of the self-supporting type, built up of lattice steel sections or members and designed to carry the power conductors with necessary insulators. Ground wires and all fittings under all loading conditions. Outline diagrams of the towers required are to be furnished by the Bidder.

**2.2.3** The towers shall be fully galvanized structures built up of structural mild steel sections. All members shall be connected with bolts, nuts and spring washers.

### 2.2.4 Stubs and Superstructures:

(i) **Stub:** shall mean a set of four stub angles fully galvanized and shall include cleats, gussets, bolts and nuts, etc. the black portion of the stub being cast in foundation footings. Stub length shall correspond to foundation depth of 3-0 metres from ground level.

(ii) **Superstructure:** shall mean the galvanized tower assembly above the stubs which includes structural members like angle sections, cross arms, ground wire peaks, accessories and fittings such as gusset plates, pack washers, spring washers, ladders, step bolts, anti climbing devices and such other items which are required for completing the towers in all respect. Steel and zinc required for manufacturing these items will be arranged by the supplier.

(iii) **Bolts, nuts, spring washers, D shackles, U bolts:** Supply of bolts and nuts and spring washers, hangers/D-shackles for attaching suspension strings and 'U' bolts for attaching ground wire suspension assemblies are included in the supply of tower.

The Bidder shall make his own arrangement for procurement of required Bolt- Nuts, accessories, attachments like 'D' shackles. 'U' bolts, anchor bolts, step bolts etc from the following approved vendor of TPCODL well in advance and supply as per scheduled completion period along with the inspection at sub vendor's premises.

Sl No	Name of the approved vendor of TPCODL
1	NEXO/GKW / ASP / MAHESWARI(P) FASTNERS & BRIGHT PVT LTD / REMAX

The bolt nuts shall be procured from the above manufacturer's approved by TPCODL. For any other make of bolt nuts, the Bidder will have to take prior approval of the TPCODL. For such approval the Bidder has to submit the following in respect of prospective bolt- nut supplier.

- (1) Plant Capacity per annum.
- (2) Type test reports for bolt nuts to be supplied (not older than 5 years).
- (3) List of orders executed / under execution.
- (4) However, TPCODL reserves right to test the samples of Bolts & nuts of the proposed Bolt-nut supplier before approving the make. TPCODL is at liberty to have samples of steel, zinc etc. to be used, test, check in any Laboratory recognized by the Government at the cost of Bidder and reject the material if found below standard.

(5) The zinc used for galvanizing of fabricated materials shall be electrolytic high grade zinc (99.95% Purity).

(iv) **Procurement of Steel and Zinc:** The following provisions shall apply in connection with the procurement of steel and zinc by the supplier.

(a) The steel used for fabrication of tower parts extensions, templates etc. shall be of mild steel of tested quality as per IS: 2062 GRA.

(b) The Bidder shall take into account the fabrication wastage while quoting the rates. The employer will not accept any liability in connection with the wastage of steel during fabrication or otherwise.

(c) The Bidder shall indicate in his offer the sizes of steel sections which are proposed to be used by him in the design of towers.

(d) Substitutions, if any, of steel sections of the tower parts by higher sizes, due to non-availability or otherwise shall be to the supplier's account. The employer will not accept any liability on this account.

(e) **The contractor shall procure all structural steel members i.e. Angles, tees, Plates, nuts & bolts etc. conforming to relevant I.S. Codes from main producers as approved by the Ministry of Steel namely SAIL, TISCO, ISCO and RINL. All MS angles, Tees and Plates shall be of grade 'A' as per IS: 2062-1999 and IS: 8500-1991. Samples shall also be taken and got tested by the Engineer-in-charge as per the provisions in this regard in the relevant I.S. Codes. In case the test results indicate that the steel arranged by the contractor does not conform to I.S. Codes, the same shall stand rejected. The proof of manufacturer of structural steel members from virgin billets purchased from main steel producers is to be furnished by him before tower member / templates are cut.**

(f) **Structural steel section not available from main producers can be procured from secondary producers/re-rollers subject to production of proof of manufacture of structural steel members from virgin billets produced from main steel producers before starting fabrication work. In case of sections not rolled by main producers, can be procured from re-rollers provided.**

**Production of proof of manufacture of structural steel members from virgin billets produced from main steel producers before starting fabrication work.**

- Re-rolling of structural steel sections is done from billets/ingots of tested quality.
- Re-rolled sections are duly tested as per relevant standard.

(g) The zinc used for galvanizing fabricated material shall be of High Grade Electrolytic zinc.

#### **2.2.5 Extensions:**

a) The towers shall be designed so as to be suitable for adding 3 metres, 6 metres, 9 metres extensions for maintaining adequate ground clearances without reducing the specified factor of safety in any manner.

b) The Bidder shall have to design leg extensions for all types of towers ranging from minus 3 metres to plus 9 metres at intervals of 1.5 metres and such leg extensions shall be suitable for being fitted to a normal tower as well as a tower with extensions. This is to enable tower spotting in hilly terrain.

#### **2.2.6 Stub setting Templates:**

Stub templates shall be designed and supplied by the supplier as per requirement for all types of towers with or without extensions. Stub templates for standard towers and towers with extension shall be fixed type. The stub templates shall be painted with anti-corrosive paints.

## 2.2.7 Fasteners: Bolts, Nuts & Washers to be used for the towers

2.2.8 All bolts shall be of property class 5.6 and nuts of property class 5.0 IS: 1367 (Part -3) 1991 and IS: 6639-1972 shall conform to IS: 12427, they shall be galvanized and shall have hexagonal heads and nuts, the heads being forged out of solid steel rods and shall be truly concentric and square with the shank. The shank shall be perfectly straight.

2.2.9 Manually threaded bolts shall not be used, the length of bolts should be such that the threaded portion shall not extend into the place of contact of the members.

2.2.10 (i) The bolts shall be threaded to take the full depth of the nut and threaded far enough to permit VARIABLE gripping of the members, but not any further. It shall be ensured that the threaded portion of each bolt protrudes not less than 3 mm and not more than 8 mm when fully tightened. All nuts shall fit hand tight to the point where the shank of the bolt connects to the head.

(ii) Flat and tapered washers shall be provided wherever necessary. Spring washers shall be provided for insertion under all nuts. These washers shall be of electro-galvanized steel and of the positive lock type. Their thickness shall be 2.5 mm for 12 mm dia bolts, 3.5 mm for 16 mm dia bolts and 4.5 mm for 20 mm dia bolts.

(iii) The Bidder shall furnish bolt schedules giving thickness of members connected, size of bolts and nuts, the length of the shank, the length of the threaded portion of bolts, sizes of bolt holes, thickness of washers and any other special details of this nature.

(iv) To obviate bending stress in bolts or to reduce it to a minimum, no bolt shall connect aggregate thickness of more than three (3) times its dia.

(v) The bolt positions in assembled towers shall be as per IS: 5613 (Part-I/Section-I) (Part-II/Section-2)-1985.

(vi) Bolts at the joints shall be so staggered that nuts may be tightened with spanners without fouling.

## 3.0 TOWER ACCESSORIES

**3.1 Step Bolt Ladders:** These bolts shall be of property class 4.6 conform to IS: 6639-1972. Each tower shall be provided with step bolts on one of the main legs, of not less than 16 mm diameter and 175 mm long, spaced not more than 400 mm apart and extending from about 2.5 metres above the ground level to the top of the tower. Each step bolt shall be provided with two nuts on one end to fasten the bolt security to the tower and button head at the other end to prevent the feet from slipping away. The step bolts shall be capable of withstanding a vertical load not less than 1.5 KN and shall be used as a ladder for climbing.

**3.2 Anti-climbing devices:** This shall conform to IS: 5613 (Part-I/Sec -I), 19085.

Fully galvanized barbed wire type anti-climbing device shall be provided at a height of approximately 3 metres as an anti-climbing measure. Four layers of barbed wires will be provided each inside and outside the tower in horizontal plane, spacing between the layers being 140 to 150 mm. The towers to be designed by the supplier shall have provision to fix the barbed wire as indicated above. Thus the angle pieces with notches for accommodating barbed wire shall be designed and supplied with the towers along with provision for suitable bolt holes on leg members for fitting bolt holes on leg member for fitting the angles. The scheme of the anti-climbing device shall be submitted along with the tower drawing. Barbed wire shall be included in the scope of bidder.

**3.3 Insulator strings and ground wire clamp attachments:** For the attachment of suspension insulator strings a suitable swinging hanger on the tower shall be provided so as to obtain requisite clearance under extreme swinging conditions and free swinging of the string. The hanger shall be designed to withstand an ultimate tensile strength of 11.500 kg.

(a) For ground wires at suspension towers suitable 'U' Bolts strong enough to withstand the full designed loads shall be provided to accommodate the hook of the ground wire suspension clamps.

(b) At tension towers, horizontal strain plates of suitable dimensions on the underside of each power cross-arm tip and at the top ground wire peak shall be provided for taking the 'D' Shackles of the tension insulator strings or ground wire tension clamps, as the case may be. Full details of the attachments shall be submitted by the supplier for the employer's approval before commencing with mass fabrication.

**3.4 Phase Plate:** Phase plate shall be of mild steel of 16 gauge vitreous enameled at back and front, circular in shape and diameter 75 mm. One set of phase plate shall be consisting of 3 plates red, yellow and blue coloured accordingly to indicate the phase of the conductor. There shall be one fixing bolt on the plate. This shall conform to IS: 5613 (Part-II/Section01) of latest edition.

**3.5 Number Plate:** The number plate shall be mild steel vitreous enameled at back and front, 200 mm x 150 mm, rectangular shape and inscribed thereon shall be the number of the tower location preceded by letter corresponding to the short name of the line and the type of towers. There shall be two fixing bolts on both end of the plates. The dimension and details of the number plate shall be as per IS: 5613 (Part-II/Section1 & Section-2), 1985.

**3.6 Danger Plate:** These shall be of mild steel vitreous enameled at back and front 250 x 200 mm rectangular shape and inscribed thereon shall be in signal red the work 'DANGER' with its Oriya and Hindi translation and also with the inscription of Bone and Skull and voltage of the line. There shall be two holes on the plates for fixing. This shall conform to IS: 2551 (latest edition).

#### **4.0 DETAILS TO TOWER FABRICATION WORKMANSHIP**

**4.1** Except where hereinafter modified details of fabrications shall conform to IS: 802 (Part-II)-1978.

**4.2** But splices shall generally be used such that the inside cleat angle and outside plates are designed to transmit load. The inside cleat angle shall not be less than half the thickness of the connected heaviest member plus 2 mm. Lap splices may also be used for connecting members of unequal size in such a manner that the inside angle of the lap splice shall be rounded at the heel to fit the fillet of the outside angle. All splices shall develop full stress in the members connected through bolts. But as well as lap splice shall be made as above and as close to and above the main panel point as far as possible.

**4.3** Joints shall be so designed so as to avoid eccentricity. The use of gusset plates for joining tower members shall be avoided as far as possible. However, where connections are such that the elimination of the gusset plates would result in eccentric joints then gusset plates and spacer plates may be used in conformity with modern practices. The thickness of the gusset plate, required to transmit stress, shall not be less than that of the thinnest of connected member but not less than 5 mm in any case.

The use of filler in connection shall be avoided as far as possible. The diagonal web members in tension may be connected entirely to the gusset plate where necessary so as to avoid the use of filler and it shall be connected at the point of inter-section by one or more bolts.

**4.4** The tower structures shall be accurately fabricated to bolt together easily at site without any strain on the bolts.

4.4 No angle member shall have the two leg flanges brought together by closing the angle.

4.5 The diameter of the hole shall be equal to the diameter of bolt plus 1.5 mm.

4.6 The structure shall be designed such that all parts are accessible for inspection and cleaning. Drain holes shall be provided at all points where pockets of depressions are likely to hold water.

All similar parts shall be made strictly interchangeable. All steel sections before any work is done on them, shall be carefully leveled, straightened and made true to detailed drawings by methods which shall not injure the materials so that when assembled, the different matching surfaces are in close contact throughout. No rough edges shall be permitted anywhere in the structure.

## **5.0 DRILLING AND PUNCHING**

(a) Before any cutting work is started, all steel sections shall be carefully straightened and trued by pressure and not by hammering. They shall again be trued after being punched and drilled.

(b) Holes for bolts shall be drilled or punched with a jig but drilled holes are preferred. The following maximum tolerance of accuracy of punched holes is permissible.

(i) Holes must be perfectly circular and no tolerance in this respect is permissible.

(ii) The maximum allowable difference in diameter of the holes on the two sides of plates or angle is 0.8 mm i.e. the allowable taper in punched holes should not exceed 0.8 mm on diameter.

(iii) Holes must be square with the plates or angles and have their walls parallel.

(c) All burrs left by drills or punches shall be removed completely when the tower members are truly opposite to each other. Drilling or reaming to enlarge defective holes is not permitted.

## **6.0 ERECTION MARK:**

Each individual member shall have an erection mark conforming to the component number given to it in the fabrication drawings. This mark shall be done with marking dies of 16 mm size before galvanizing and shall be legible after galvanising. The erection mark shall be A-BB-CC-DDD where:

**A:** Employer code assigned to the supplier (alphabet)

**BB:** Supplier's mark (Numerical)

**CC:** Tower type (Alphabet)

**DDD:** Number mark to be assigned by the supplier (Numerical)

## **7.0 GALVANIZING**



The super structure of all towers and stubs upto 150 mm below plinth level (Top of concrete pedestal) shall be galvanized. Galvanizing of tower members and stub shall be in conformity with IS: 4759-1984 and shall be done after all fabrication work has been completed except that the nuts may be tapped or return after galvanizing. Threads of bolts and nuts after galvanizing shall have a neat fit and shall be such that they can be turned with fingers throughout the length of the threads of bolts and they shall be capable of developing the full strength of the bolts. Spring washers shall be electro-galvanized as per Grade – 4 of IS: 1573 – 1986. Galvanizing for fasteners shall conform to IS: 1367 (Part-XIII) – 1978.

## **8.0 QUANTITIES AND WEIGHTS**

**8.1** The quantities stated in Annexure–I are only provisional. Final quantities will be informed by the employer to the supplier on completion of detailed survey. However, bid will be evaluated based on quantities indicated in the Annexure – I.

**8.2** The employer reserves the right to order for the final quantities at the rates quoted in the bid, which shall be valid throughout the pendency of the contract.

**8.3** The unit weight of each type of tower stubs, super structure and extension be furnished by the Bidder. The weight of tower shall mean the weight of tower calculated by using the black section (non galvanized) weight of steel members including stubs, of the sizes indicated in the approved fabrication drawings and bills of materials, without taking into consideration the reduction in weights due to holes, notches, cuts, etc. but taking into consideration the weight of special fittings.

## **9.0 TOWER DESIGNS SUPERSTRUCTURE**

### **9.1 Wind Pressure**

The wind pressure on towers, power conductors and earth wire shall be as per IS: 802 (Part-I/Sec-I) – 1995. 280

### **9.2 Design Temperatures**

The following temperature range for the power conductor and ground wires shall be adopted for the line design confirming to IS: 802 (Part –I/Sec – I) – 1995.

- i) Minimum temperature: 50°C.
- ii) Every day temperature: 32°C
- iii) Maximum temperature of Conductor: 75°C [For ACSR Zebra/Panther]  
90°C [For AAAC Moose equivalent]
- iv) Ground wire- 53°C (exposed to Sun)

### **9.3 Factors of Safety & Span details**

(a) **Factory of safety:** The factor of safety based on crippling strength of struts and elastic limit of tension members shall not be less than 2 (two) under normal condition and 1.5 (one and a half) under broken wire conditions for all the members of the towers and their cross arms.

(b) **Normal Span:** The normal span of the line shall be 300 metres for 220 kV and 250 metres for 132 kV.

(c) **Wind and weight spans:** The wind and weight spans to be adopted in the design of the structures shall be as follows:

(i) **Wind Span:** The wind span is the sum of the two half spans adjacent to the support under consideration. In case of towers located on a perfectly horizontal terrain, this shall be the normal span. For design purposes the wind on conductor shall be calculated on at least 1.1 times the normal.

(ii) **Weight Span:** The weight span is the horizontal distance between the lowest point of the conductors on the two spans adjacent to the tower. All C and D type towers shall be designed for uplift spans (minimum) weight spans in the following table also. These are applicable both for pointed and square cross arms.

For details of cross arms and towers, the span limits given below shall prevail.

**WEIGHT SPANS**

Tower Type	Normal Condition		Broken wire condition		Normal Condition		Broken wire condition	
	Max	Min	Max	Min	Max	Min	Max	Min
A & B	525	100	300	100	488	100	195	100
C & D	600	100	300	100	576	100	195	100

**9.4 Conductor and Ground wire Configuration:** For single circuit towers the three phases shall be Delta formation. One number of ACSR/AAAC conductor shall be used for each phase. One galvanized steel wire shall be used as ground wire. The ground wire shall be continuous and shall be provided above the conductors at suitable elevation to offer effective shielding and safe clearances. For double circuit towers the phases shall be in vertical formation with phase to phase horizontal spacing of not less than 8.4 meters and vertical 4.9 meters for 220 kV.

**9.5 Loads on Towers**

(i) **Transverse Loads:** Transverse load due to wind on towers conductors and under broken wire earth wire shall be calculated in accordance with IS: 802(Part-I/Sec-I)-1995.

(ii) **Longitudinal Loads:** Longitudinal loads due to wind on towers conductors and shield shall be calculated as per IS: 802 (Part-I/Sec-I)-1995.

(iii) **Vertical Loads:** The vertical load due to conductors and ground wire shall also include 150 kg ss weight of a Lineman with tools. These loads are in addition to the vertical loads due to insulator fittings and the dead weight of the structure. The weight of a Lineman with tool should not be considered in minimum vertical load calculation. An additional erection load of 3.5 KN shall also be considered for the design of the tower. The stringing procedure shall ensure that the above vertical loads are not exceeded. For calculating vertical loads the following insulator weights may be considered.

Type string	220 KV	132 KV
Each single suspension insulator string	160 kg	120 Kg
Each double suspension insulator string	320 kg	240 Kg
Each double tension insulator string	420 kg	320 Kg
Pilot string for 60° tower	160 kg	120 Kg

**iv) Broken Wire condition**

a) **Suspension Tower Type A/DA:** Breaking of any one power conductor in one phase only, resulting in instantaneous unbalance tension of 50% of conductor tension at 32°C without wind or breaking of one earth wire resulting in an unbalance tension equal to the maximum tension of the ground wire whichever is more stringent is to be considered for design along with appropriate impact factor.

**b) Tower Type B & C**

Breakage of two phases on the same side and on the same span or breakage of any one phase and any one ground wire on the same span whichever combination is more stringent along with appropriate impact factor for a particular member.



### c) Tower Type D/DD

Breakage of all the three phases on the same side and on the same span or breakage of two phases and any one ground wire on the same span, whichever combination is more stringent along with appropriate impact factor for a particular member. Cross arms for angle tower shall be of equal length for both sides.

### v) Design Load

Employer's requirement for design longitudinal and transverse loads shall confirm to IS: 802(Part-I/Sec-I)-1995. The Bidder shall furnish the details of design loads proposed to be adopted in the tower design in accordance with this specification. The design criteria and other special requirements as stipulated for special towers shall be applicable for river crossing/special towers.

## 9.6 Tower Steel Sections:

i) **Tower steel sections:** Steel sections of tested quality in conformity with IS: 2062 GRA are to be used in towers, extensions and stub setting templates. No individual members shall be longer than 6000 mm. For designing of towers only rationalized steel sections shall be used. During execution of the project, if any particular section is not available, the same shall be substituted by higher section at no extra cost. However, design approval for such substitution shall be obtained from the employer.

ii) **Thickness of Members:** The minimum thickness of angle sections used in the design of towers, shall be kept not less than the following values:

- a) Main corner leg members excluding the ground wire peak and main cross arm 6 mm.
- b) For all other main members 5 mm.
- c) Redundant members 4 mm.

iii) **Bolt Arrangement:** The minimum bolt spacing and rolled edge distance and sheared edge distances of sections from the centers of the bolt holes shall be provided as furnished in Table below.

Dia of Bolts (mm)	Hole Dia (mm)	Min. bolt Spacing (mm)	Min. rolled Distance (mm)	Min. Sheared Edge distance (mm)
12	13.5	30	16	19
16	17.5	40	20	23
20	21.5	50	25	27

Bolts sizes mentioned above shall only be used. The minimum width of flanges without bolt holes shall be 30 mm. For the purpose of calculating stress and bearing stress for bolts refer clause 14.4 and 14.5 of IS: 802 (Part-I/Sec-2)-1992.

iv) **Allowable Stress:** Structural steel angle section manufactured according to the latest ISL: 808(Part-V & VI) and tested according to the latest edition of IS:2062 and having its yield strength not less than 255 N/mm. sq. shall be used in the fabrication of tower members.

v) **Axial Stress in tension:** The estimated tensile stress in various members multiplied by the appropriate factors of safety shall not exceed the value given by the formula specified in Clause 9.2.1 of IS:802(Part-I/Sec-2)-1992.

vi) **Axial Stress in Compression:** The estimated compressive stress in various members multiplied by the appropriate factors of safety shall not exceed the value given by the formula specified in Clause 9.2.1 of IS:802(Part-I/Sec-2)-1992.

vii) **Slenderness ratio:** Slenderness ratio for members shall be computed in accordance with IS:802(Part-I/Sec-2)-1992. Slenderness ratio for compression and tension members shall not exceed the values specified therein. The following maximum limits of the slenderness ratio shall be adopted i.e. the ratio of unsupported length of the section in any place to the appropriate radius of gyration.

a)	For main corner leg member including the corner members of earth wire peak and the lower corner members of the arms...	150
b)	For other members having calculated stresses....	200
c)	For redundant members....	250
d)	For members having tensile stress only....	375

viii) **Erection Stress:** Where erection stresses combined with other permissible co-existent stresses could produce a working stress in any member appreciably above the specified working stress, then additional materials shall be added to the member or such other provision made so as to bring the working stress within the specified limit. For the purpose of this clause the specified working stress shall be the ultimate stress divided by the factor of safety of 2.0.

ix) **Design calculation and Drawings:** The following design calculations and drawings are required to be furnished to the employer.

a) **Along with the Bid:** Detailed design calculations and drawing for each type of tower.

b) **On award of Contract:** The supplier shall submit design of tower extension, stub templates and loading/rigging arrangement of tower testing to enable the employer to make preliminary check regarding structural stability of tower tests. Upon successful testing of tower and subsequent approval of designs, drawings and bill of materials, the supplier shall furnish Photostat copies of the following in 6(six) copies to the employer for necessary distribution along with one copy of reproducible print.

a) Detailed design calculations along with drawings of towers and foundations.

b) Detailed structural drawings indicating section size, length of member. Sizes of plate along with hole to hole distances, joint details etc.

c) Bill of materials indicating cutting and bending details against each member.

d) Shop drawings showing all details relevant to fabrication.

e) All drawings for the tower accessories.

The supplier is required to submit four copies of the drawings with Photostat copies mentioned above for approval by the employer while submitting the designs, structural drawings, bill of materials & any other drawings pertaining to the subject transmission line. The supplier shall clearly indicate in each drawing the project code number, if any, specification no, name of transmission line, letter reference no. and date on which the submissions are made. The said procedure is to be followed while submitting the distribution copies.

**9.7 Statutory Clearances:** This should be as per ISS.

(i) **Ground Clearances:** The minimum ground clearance from the bottom conductor shall not be less than 7.00 meters for 220 kV at the maximum sag conditions i.e. at maximum temperature and in still air. However, to achieve the above clearance the height of the tower shall be increased in the following manner:

- (a) An allowance of 4% of the maximum sag shall be provided to account for errors in stringing.
- (b) Conductor creep shall be compensated by over tensioning the conductor for a temperature of 26°C lower than the stringing temperature. In case of rail track crossings the minimum height above rail level of the lowest portion of any conductor under conditions of maximum sag, in accordance with the regulations for Electrical Crossing of Railway Tracks are given in Table below.

Sl No	Type of work	Inside stn. Limits (mm)	Outside stn. Limits (mm)
a)	For un-electrified track and tracks electrified on 1500 V.DC		
	i) For metre/narrow gauge	10,000/17,600	
	ii) For broad gauge	11,200	8,800
b)	Tracks electrified on 25 kV AC for meter, narrow and broad gauge	15,400	13,400

Minimum clearance between the subject power line and any other power line crossing shall not be less than 7000 mm.

(ii) **Live Metal Clearance:** The minimum live metal clearance to be provided between the live parts and steel work of superstructure shall be as given in IS:5613 (Part-2/Sec-I). The Bidder may adopt separate cross arm design and length for 'D' type towers under dead end conditions provided adequate live metal clearance is available with at least 15° angle and also provided that all the other specified conditions of this specifications are fulfilled. In case pilot insulator strings are proposed to be used, the angle of swing to be considered shall be minimum of 15°. In computing live metal clearances, the dimensions of suspension and tension string shall be taken as given in drawings attached herewith. The design of the towers shall be such that it should satisfy all the above conditions when clearances are measured from any live point of the insulator strings.

(iii) **Angle Shielding:** The angle shielding, defined as the angle formed by the line joining the center lines of the ground wire and outer conductor in still air, at tower supports, to the vertical line through the center line of the ground wire shall not be more than 30°. The drop of the ground wire clamp which is employer supplied item should be considered while calculating the minimum angle of protection. For estimating the minimum angle of protection the drop of ground wire suspension clamp along with U-bolt may be taken as 150 mm.

(iv) **Midspan Clearance:** The minimum vertical span clearance between any of the earth wire and the nearest power conductor under all temperatures and in still air condition in the normal ruling span shall be 8.10 meters for 220 kV. Further the tensions of the earth wires and power conductors shall be so co-ordinated that the sag of earth wires shall be at least 10% less than that of the power conductors under all temperatures and loading conditions.

**9.8 Packing:** Angle sections shall be wire bundled, cleat angles, gusset plates, blackets, filler plates, hanger and similar other loose items shall be netted and bolted together in multiples or securely wired together through holes. Bolts, nuts, washers and other attachments shall be packed in double gunny bags, accurately tagged, in accordance with the contents. The packing shall be properly done to avoid losses/damages during transit. Each bundle or package shall be appropriately marked.

## 9.9 Special Towers:

(i) Special towers are to be used for Major River crossing requiring very long spans. These towers shall form part of the Bidder's scope. Unit rates for design, fabrication, galvanizing, testing and supply for such towers shall be quoted in the appropriate schedule of Volume IB. Anchoring of Major River crossing towers, shall be with 'D' or DD type towers. All the requirements as meant for standard towers shall apply for such special towers except those noted in the following clauses.

(ii) **Shielding Angle:** The shielding angle shall not be greater than 30°.

(iii) **Clearances:** The minimum clearance of lowest point of power conductor from the highest flood level in navigable rivers for crossing towers shall be obtained from the navigation authority. The minimum electrical clearances between live parts and tower body and cross arm member shall be the same as for normal towers.

(iv) **Stub location:** The approximate height of foundation on which stub for river cross towers are to be set, over the highest flood level of the river shall be fixed only after employer's approval.

(v) **Angle of Deviation:** The minimum angle of deviation to be considered for special towers is 2° and all live material clearances are to be computed considering double suspension insulator strings as per drawing enclosed.

(vi) **Factors of Safety:**

(1) **Towers:**

The minimum factors of safety for towers shall be:

- a) Under normal conditions 2.0
- b) Under broken wire conditions 1.5

(2) **Conductor and Earth wire:** The minimum factor of safety for conductors and ground wire shall be 2.5 maximum tension corresponding to 2/3<sup>rd</sup> full wind pressure at minimum temperature or full wind pressure at the mean annual temperature such that the initial unloaded tension at the mean annual temperature do not exceed 30% of the ultimate strength of conductor and ground wire respectively.

(vii) **Wind Loads:** The procedure for wind load calculation on conductor and ground wire shall be the same as for normal structures.

(a) The wind pressure values on tower shall be based on IS:802(Part-I/Sec-I)-1995.

(viii) **Longitudinal Loads:**

- a) The longitudinal loads due to power conductors and earth wires for suspension towers shall be nil under normal conditions and 100% of the maximum tension of bundled conductors or earth wire under broken wire conditions.
- b) Under normal conditions, unbalanced longitudinal pull due to difference in tension in ruling span for river crossing towers on one side and span of the line on the other wise shall also be considered for the design of anchor towers.

## 10.0 TESTS

### 10.1 General

(a) All standard tests including quality control tests in accordance with IS:802 (Part-III)-1978 shall be carried out.

(b) A galvanized tower of each type complete with 6 meters extension shall be subjected to design and destruction test. The tower shall be tested with nuts and bolts of the same make and type which are proposed to be used on the line. The supplier shall submit to

the employer for approval, a detailed programme and proposal for testing the towers showing the method of carrying out the tests and the manner of applying the loads. The supplier on receipt of such approval shall intimate the employer about carrying out of the tests at least 30 days in advance of the scheduled date of tests during which time the employer will arrange to depute his representatives to witness the tests. Six copies of the test reports thereof shall be submitted to the employer for approval.

(c) In case of premature failure, the tower shall be retested and steel already used in the earlier test shall not be used again. The supplier shall provide facilities to the employer for inspection of materials during manufacturing stage and also during testing of the same.

(d) No part of any tower subject to test shall be allowed to be used in the work. The prices to be quoted for such type tests shall be after allowing rebate for the scrap value of the tested tower which is to be retained by the supplier.

(e) The supplier shall ensure that the specification of materials and workmanship of all towers actually supplied conform strictly to the towers which have successfully undergone the tests. In case any deviation is detected the supplier shall replace such defective towers free of cost of the employer. All expenditure incurred in erection, to and fro transportation, any other expenditure or losses incurred on this account shall be fully borne by the supplier. No extension in delivery time shall be allowed on this account. The employer, however, reserves the right to waive off the testing of the towers, provided the supplier had earlier successfully tested, erected and commissioned similar towers and certificates for such tests carried out earlier are furnished duly certified by the employer and is found acceptable.

(f) Each type of tower to be tested shall be a full scale prototype galvanized tower and shall be erected vertically on rigid foundation with the stub protruding above ground level as provided in the design/drawing between ground level and concrete level.

(g) The suspension tower to be tested shall be with hanger and 'U' Bolt as per approved design/drawings. The tension tower to be tested shall similarly be with the strain plate as per approved design/drawings.

(h) In case of any premature failure even during waiting period, the tower shall be retested with rectified members. However, if the failures are major in nature and considerable portion of tower is to be re-erected then in such cases all the tests which have been carried out earlier are to be re-conducted to the entire satisfaction of the employer.

(i) The sequence of testing shall be at the discretion of the employer.

**10.2 Test for Galvanization:** Galvanization of the members of the tower shall withstand tests as per IS: 2633.

### **10.3 Inspection:**

**10.3.1** The supplier shall keep the employer informed well in advance of the commencement of manufacture, progress of manufacture thereof and fabrication of various tower parts at various stages. So that arrangements could be made for inspection by the employer.

**10.3.2** The acceptance of any batch of items shall in no way relieve the supplier of any his responsibilities for meeting all the requirements and intent of this specification and shall not prevent subsequent rejection if any item of that batch is later found defective.

**10.3.3** The employer or his authorized representatives shall have free access at all reasonable time to all parts of the supplier's works connected with the fabrication of the material covered under the contract for satisfying them that the fabrication is being done in accordance with the provisions of this specification.

**10.3.4** Unless specified otherwise, inspection shall be made at the place of manufacture prior to dispatch and shall be conducted so as not to interfere unnecessarily with the operation of the work.

**10.3.4** Should any member of the structure be found not to comply with the approved design, it shall be liable for rejection. No member once rejected shall be resubmitted for inspection except in cases where the employer or his authorized representative considers that the defects can be rectified.

**10.3.5** Defects which occur during fabrication shall be made good with the consent of and according to the procedure to be laid down by the employer.

**10.3.6** All gauges and templates necessary to satisfy the employer for conducting tests shall be made available at the test site by the supplier.

**10.3.7** The correct grade and quality of steel shall be used by the supplier. To ascertain the quality of steel the employer may at his discretion get the material tested at an approved laboratory.

#### **10.4 Schedule of requirements:**

**10.4.1** The present schedule of requirements of different types of towers will be informed to the supplier at the time of placing order. The supplier should be ready to supply the future tower requirement of TPCODL for the rate contract period in very short notice.

**10.4.2** The time frame for executing the work is also indicated in this schedule. The supplier has to match the supply and delivery of stubs, tower-parts etc. to complete the work within the time schedule desired by the employer. Generally the supplier should supply @400MT per month as per the requirement.

**10.4.3** The supplier shall, as far as possible, despatch the tower material as completed towers in order to enable erection of complete tower structures at site. Payment for the completed towers shall only be released in case running bills are allowed.

**10.5 Schedule of prices:** The prices for supply of materials shall be furnished in the relevant schedule in the manner specified in annexure-I and Annexure-II.

1.0 ERECTION OF TOWER AND TOWER FOUNDATION

1.1 SCHEDULE OF ERECTION PROGRAMME

After due approval of the detailed and check survey, the contractor shall submit to the employer a complete detailed schedule of erection programme with a Bar-Chart for construction of the lines indicating therein the target date of completion.

1.1.1 DRAWINGS FOR TOWER AND FOUNDATIONS



The same shall be supplied by the contractor.

#### 1.1.2 TAKING OVER

Tower and tower accessories received at site stores are to be stored item-wise and mark-wise to facilitate joint inspection of the materials (with reference to packing list and detailed order).

If the materials/equipment or any part thereof is damaged or lost during the transit, the replacement of such materials shall be effected by the contractor timely so as to maintain programme of work. However, the line under erection shall be taken over by the purchaser only when the entire line is completed in all respect and made ready for commissioning at rated voltage. Partly erected line will not be taken over.

Taking over of the line shall be in no way relieve the contractor from his responsibility for satisfactory operation of the erected line in terms of the guarantee clause of the specification.

#### 1.1.3 MATERIALS HANDLING AND INSURANCE

The contractor shall deliver all equipment/materials against this contract to his site stores under cover of Transit Insurance to be taken in his name. Cost of such insurance is to be borne by the contractor.

Cost of transportation of materials from contractor's store to the site of work shall be borne by the contractor irrespective of mode of transportation and site condition.

The contractor has to bear the cost of premiums for all materials, tower accessories, total erection cost of the line including cement, cost for foundation.

It will be the responsibility of the contractor to report to the concerned Police Station about all incidents of thefts and lodge, pursue and settle all claims with Insurance Company in case of damage/loss due to theft, pilferage, flood and fire etc. and the employer of the work shall be kept informed promptly in writing about all such incidents. The loss, if any, on this account shall be recoverable from the contractor if the claims are not lodged and properly pursued in time or if the claims are not settled by the insurance company due to lapses on the part of the contractor. The contractor shall have to replenish promptly damaged, stolen tower members and accessories conductors, earth wire, hardwares etc. and repair/re-erect the damaged lines, free of cost to the employer so

as to maintain the programme of work. The employer will not be responsible in any way for such loss of materials.

#### 1.1.4 EXCAVATION FOR FOUNDATION PITS, DE-WATERING AND SHORING SETS

The contractor shall execute the open excavation job in the foundation pits in all type of soil including latterite and or boulder mixed soil as detailed abelow including removing, spreading and/or stacking the excess spils (as directed by the employer). The item includes the necessary trimming of the sides, leveling, dressing and ramming (as necessary) the bottom of the pits including bailing out water, dewatering by manual and/or mechanical means by emplying water pumps including removing of slushes from foundation pits and nominal open plank shoring with vertical poling boards placed at suitable intervals as directed with required runners, struts, battens for framing as required complete. While quoting the unit rate for foundation as per the activity schedule, the contractor shall include cost of design, all cost of labour, materials, tools, plants, incidentals for earth excavation, dewatering, cement, water, sand, coarse and find aggregates, steel reinforcement, steel angles, forms, mixing, finishing, protection and curing of concrete, back-filling with carried earth, if necessary, disposal of surplus, spoils, stub setting and template. The contractor shall also include in the quoted unit rate for foundation, all charges/costs for preparing the pit marking and foundation layout drawing, grounding of towers including supply of pipe/concrete pipe, earthing, measurement of ground resistance before often growing etc.

#### 1.1.5 CEMENT CONCRETE :

##### A) Materials

All materials whether to be consumed in the work or used temporarily shall conform to relevant IS specification, unless stated otherwise, and shall be of the best approved quality.

##### B) Cement

Cement to be used in the work under the contract shall generally conform to IS:269/455-1989. Cement bags shall be stored by the contractor in a water tight well ventilated store sheds on raised wooden platform/dunnage (raised at least 150 mm above ground level) in such a manner as to prevent deterioration due to moisture or intrusion of foreign matter. Sub-standard or partly set cement shallnot be used and shall be removed from the site by the contractor at his cost on receipt of approval from the Engineer.

##### C) Coarse Aggregates Stone chips or stone ballast

##### D) Reinforcement : Different size of reinforcement(MS ROD-FE-500) as per latest IS.

Remarks: All foundation of tower shall be of RCC: M20 Grade (1:1.5:3)nominal mix



General Technical Particulars  
**C. 1 - Span Lengths**

		<b>132Kv</b>
Normal span	m	300
Tower design spans:		
Wind spans: Suspension towers		
Tension towers Maximum weight spans:	mm	300
Suspension towers Tension towers		300
Minimum weight spans: Suspension towers Tension towers (uplift net)	mm	450
	mm	450
		100
		-200

C . 2 - Line Conductor ( 33 kV Construction )

<b>Complete line conductor:</b>		
Actual area (total) per single conductor	mm <sup>2</sup>	288.3
Number of conductors per phase	mm	ONE
Horizontal distance between conductor centres one phase	of	-
<b>Each single conductor:</b>		
Equivalent to ACSR conductor of code name		ACSR PANTHER
IEC STANDARD No		IEC 1089
INDIAN STANDARD No		IS 398 (Pt 4) 1994
Material of conductor		AlumIniniu m
Number and diameter of wires: Aluminium	No./mm	30/3.0
Total area of conductor	mm <sup>2</sup>	261.5
Overall diameter of stranded conductor	mm	21
Mass of conductor per kilometre	kg	974
Ultimate strength of conductor	Newton	89670
Assumed equivalent modulus of elasticity of Conductor	N/mm <sup>2</sup>	81580
Assumed equivalent coefficient of linear expansion of conductor	per °C	17.8x 10 <sup>-6</sup>
Maximum length of conductor supplied on one Drum	km	2.4+/-5%

**\*\*ALL THE CONDUCTORS ARE ACSR CONDUCTORS HAVING 7 STRANDS OF GI  
STEEL WIE**

5 - Earth Wire (33KV Constructions)

		<b>GSW</b>
<b>Complete earth conductor:</b>		
Appropriate Indian Standard No		398(Part-2)
Appropriate British Standard No		183
Material of conductor		galvanised steel
Number and diameter of wires	No./m	7/3.15
	m	
Overall diameter of conductor	mm	9.45
Mass of conductor per kilometre	kg	428
Ultimate strength of conductor	Newto	56000
	n	
Lay length	mm	160 +/- 15
Direction of the lay of the outer layer		Right hand
Chemical composition of the steel wire	%	
Carbon		not more than 0.55
Manganese		0.4 to 0.9
Phosphorous		not more than 0.04
Sulphur		not more than 0.04
Silicon		0.15 to 0.35
Purity of Zinc for galvanising	%	99.95
Galvanising after stranding		
a) Minimum weight of Zinc coating per sq. m. of the uncoated wire surface	gms	240
b) Minimum no. of one minute dips that the galvanised wire can withstand in Standard Preece Test		3 and 1/2
Maximum length of conductor on drum #	km	4 +/- 5%
D.C. resistance at 20 °C	ohms/k	3.375
	m	

### C . 28 - Foundation Design Particulars

Assumed density of Plain Cement Concrete (PCC) for foundation in dry soil	kg/m <sup>3</sup>	2240
Assumed density of Plain Cement Concrete (PCC) for foundation in presence of sub-soil water	kg/m <sup>3</sup>	1240
Assumed density of Re-inforced Cement Concrete (RCC) for foundation in dry soil	kg/m <sup>3</sup>	2400
Assumed density of Re-inforced Cement Concrete (RCC) for foundation in presence of sub-soil water	kg/m <sup>3</sup>	1400
28 day concrete cube strength (characteristic strength for M-20 concrete)	N/mm <sup>2</sup>	20
28 day concrete cube strength (characteristic strength for M-15 concrete)	N/mm <sup>2</sup>	15
Minimum proportion of stub load to be allowed for in the design of stub cleats	%	100
Density of all type of soils :		
1) under dry conditions	kg/m <sup>3</sup>	1440
2) in presence of surface water	kg/m <sup>3</sup>	1440
3) in presence of sub-soil water	kg/m <sup>3</sup>	840
Ultimate bearing capacity of the soil :		
1) normal soil under dry condition	kN/m <sup>2</sup>	214
2) normal soil in presence of surface as well as sub-soil water	kN/m <sup>2</sup>	107
3) wet black cotton soil	kN/m <sup>2</sup>	107
4) fissured rock ( both for dry and wet )	kN/m <sup>2</sup>	400
5) hard rock	kN/m <sup>2</sup>	750
Angle of repose for :		
1) dry soil	Degree	30
2) wet soil due to presence of surface/ sub-soil	Degree	15
Water		
3) wet black cotton soil	Degree	0
4) dry fissured rock	Degree	20
5) wet fissured rock	Degree	10
Ultimate bond between steel and concrete	kN/m <sup>2</sup>	0.147

**Note :** All the soil parameters furnished above are subject to verification by actual soil investigations. The Contractor shall be required to carry-out field test for each type of foundation, as per the quoted rates in Price Schedules, to prove the design parameters considered.

The foundation classification criteria shall be as given below, depending upon type of soil and sub-soil water level / presence of surface water :

**Normal Dry :** To be used for locations where normal dry cohesive or non-cohesive soils are met without encountering sub-soil water table within the depth of foundation.

**Wet :** To be used for locations,

a) where sub-soil water is met at 1.5 m. or more below the ground level;

b) which are in surface water for long periods with water penetration not exceeding one metre below the ground level e.g. , the paddy field.

**Partially Submerged :** To be used for the locations where sub-soil water table is met between 0.75 to 1.5 m. below the ground level;

**Fully Submerged :** To be used for locations where sub-soil water table is met at less than 0.75 m. below the ground level;

**Black Cotton Type :** To be used at locations where soil is clayey type, not necessarily black in colour, which shrinks when dry and swells when wet, resulting in differential movement. For designing the foundation for such locations, the soil is to be considered as fully submerged.

**Fissured Rock :** To be used at locations where decomposed or fissured rock, hard gravel, kankar, lime-stone, laterite or any other soil of similar nature is met. Under-cut type foundation is to be used for such locations.

In case of fissured rock locations where water table is met at 1.5 m. or more below ground level, wet type fissured rock foundations shall be adopted.

**Hard Rock :** To be used for the locations where chiselling, drilling or blasting is required for excavation . For these locations rock anchoring is to be provided to resist the uplift forces

# **PILE FOUNDATION-**

- a) **SCOPE-** The work involved is to take up the pile foundation work of including stub setting of special type tower. The detailed survey, soil investigation and the design has to be done bidder and the design is to be approved by **TPCODL**, which shall be strictly followed by the contractor. The contractor shall cast the foundation including stub setting as per the design, the schedule of quantities enclosed and direction of engineer in charge.
- b) 1. The pile foundation shall be of RCC, Cast-in-situ bored piles as per IS:2911 . Pile boring shall be done using Rotary Hydraulic Rigs. Two stage flushing of pile bore shall be ensured by airlift technique duly approved by the Employer
2. Minimum diameters of piles shall be 450/500mm (for under reamed piles)/ 600 mm (for bored cast in situ piles).
3. Only straight shaft piles shall be used. Minimum cast length of pile above cutoff level shall be 1.0 m.
4. The bidder shall furnish design of piles (in terms of rated capacity, length, diameter, termination criteria to locate the founding level for construction of pile in terms of measurable parameter, reinforcement for job as well as test piles, locations of initial test piles etc.) for Engineer's approval.
5. The piling work shall be carried out in accordance with IS:2911 (Relevant part) and accepted construction methodology. The construction methodology shall be submitted by the Contractor for Engineer's approval.
6. Number of initial load tests to be performed for each diameter and rated capacity of pile shall be subject to minimum as under.
- Vertical  
Lateral : Minimum of 2 Nos. in each mode  
Uplift
7. The initial pile load test shall be conducted with test load upto three times the estimated pile capacity. In case of compression test (initial test) the method of loading shall be cyclic as per IS:2911 (relevant part).
8. Load test shall be conducted at pile cut of level (COL). If the water table is above the COL the test pit shall be kept dry through out the test period by suitable de-watering methods. Alternatively the vertical load test may be conducted at a level higher than COL. In such a case,an annular space shall be created to remove the effect of skin friction above COL by providingan outer casing of suitable diameter larger than the pile diameter
9. Number of routine pile load tests to be performed for each diameter/allowable capacity of pile shall be as under :
- (i) Vertical : 0.5% of the total number of piles provided.  
(ii) Lateral : 0.5% of the total number of piles provided.



10. The routine tests on piles shall be conducted upto test load of one and half times the allowable pile capacity. Piles for routine load tests shall be approved by the Employer.
11. In case, routine pile load test shows that the pile has not achieved the desired capacity or pile(s) have been rejected due to any other reason, then the Contractor shall install additional pile(s) as required and the pile cap design shall accordingly be reviewed and modified, if required.
12. Testing of piles and interpretation of pile load test results shall be carried out as per IS:2911 (Part-4). Contractor shall ensure that all the measuring equipment and instruments are properly calibrated at a reputed laboratory / institute prior to their use. Settlement / movement of the pile top shall be made by Linear Variable Differential Transducers (LVDT) having a least count of 0.01mm.
13. The test load on initial test piles shall be applied by means of reaction from anchor piles / rock anchors alone or combination of anchor piles / rock anchors and kentledge.
14. Low Strain Pile Integrity test shall be conducted on all test piles and job piles. This test shall be used to identify the routine load test and not intended to replace the use of static load test. This test is limited to assess the imperfection of the pile shaft and shall be undertaken by an independent specialist agency. The test equipment shall be of TNO or PDI make or equivalent. The process shall conform to ASTM.
15. Contribution of frictional resistance of filled up soil if any, shall not be considered for computation of frictional resistance of piles.
16. The following shall be adhered to **PILE FOUNDATION**:
  - i) The pile foundation shall be of under reamed piles as per IS: 2911 part III or bored cast in situ piles as per IS 2911 part I sec2
  - ii) The minimum diameter of pile shall be 500 mm in case of under reamed piles and 600 mm in case of bored cast in situ piles.
  - iii) Under reamed piles shall be adopted only in case of clay black cotton soil or medium dense sandy soil is encountered. Design of under reamed shall be done strictly as per IS 2911 part III.
  - iv) The bidder shall furnish design of piles (in terms of rated capacity, length, diameter, termination criteria to locate the founding level for construction of pile in terms of measurable parameter, reinforcement for job as well as test piles, locations of initial test piles etc.) for Engineer's approval.
  - v) The piling work shall be carried out in accordance with IS:2911 (Relevant part) and accepted construction methodology. The construction methodology shall be submitted by the Contractor for Engineer's approval.
  - vi) Number of initial load tests to be performed for each diameter and rated capacity of pile shall be subject to minimum as under.

Vertical

Lateral

Uplift

Minimum of 2 Nos. in each mode.

vii) The initial pile load test shall be conducted with test load upto three times the estimated pile capacity. In case of compression test (initial test) the method of loading shall be cyclic as per IS:2911 (part IV).

viii) Load test shall be conducted at pile cut of level (COL). If the water table is above the COL the test pit shall be kept dry through out the test period by suitable de-watering methods. Alternatively the vertical load test may be conducted at a level higher than COL. In such a case, an annular space shall be created to remove the effect of skin friction above COL by providing an outer casing of suitable diameter larger than the pile diameter.

ix) Number of routine pile load tests to be performed for each diameter/allowable capacity of pile shall be as under :

i) Vertical : 0.5% of the total number of piles provided.

ii) Lateral : 0.5% of the total number of piles provided.

x) The routine tests on piles shall be conducted upto test load of one and half times the allowable pile capacity. Piles for routine load tests shall be approved by the Employer.

xi) In case, routine pile load test shows that the pile has not achieved the desired capacity or pile(s) have been rejected due to any other reason, then the Contractor shall install additional pile(s) as required and the pile cap design shall accordingly be reviewed and modified, if required.

xii) Testing of piles and interpretation of pile load test results shall be carried out as per IS:2911 (Part-4). Contractor shall ensure that all the measuring equipment and instruments are properly calibrated at a reputed laboratory / institute prior to their use. Settlement / movement of the pile top shall be made by Linear Variable Differential Transducers (LVDT) having a least count of 0.01mm.

xiii) The test load on initial test piles shall be applied by means of reaction from anchor piles / rock anchors alone or combination of anchor piles / rock anchors and kentledge.

xiv) Contribution of frictional resistance of filled up soil if any, shall not be considered for computation of frictional resistance of piles.

**a) MATERIALS-** Contractor shall supply cement, steel rod and stubs and all other materials required. All coarse aggregates, fine aggregates are to be of very good quality and to be approved by the engineer in charge.

**b) Watch and Ward-** The cost of watch and ward, site store, making of Islanding/platform for the pile boring, stabilization of bore hole and all other activities incidental to successful construction of the pile foundation are to be included in the cost of the tender and no additional cost shall be paid separately on any additional component.

The cement, steel shall be supplied to the contractor at the nearest store and the contractor shall have to receive the same at designated stores and transport to site at his own cost.

The piling shall be done in presence of the engineer in charge and due certification to be done at the spot only.

Standard followed and to be followed-

Indian Standards(IS)	Title	International and Internationally Recognize Standard/Code
IS:1080-1990	Codes of Practice for Design and Construction of Simple Spread Foundations	
IS: 1498-1992	Classification and Identification of Soils for General Engineering Purposes.	ASTM D 2487/ ASTM D 2488
IS: 1892-1992	Code of Practice For Design and Construction of Foundation in Soils : General Requirements.	
IS: 2131-1992	Method of Standard Penetration Soils	ASTM D 1586
IS: 2132-1992	Code of Practice For Thin Walled Sampling of Soils	ASTM D 1587
IS: 2720-1992	Method of Test For Soils (Relevant Parts).	ASTM D 420
IS: 2809-1991	Glossary of Terms And symbols Relating to Soil Engineering	ASTM D 653
Indian Standards(IS)	Title	International and Internationally

IS: 2911-1980	Code of Practice For Design and Construction of Pile Foundations (Relevant Parts).	
IS: 3025	Methods of Sampling And Testing (Physical And Chemical) for Water used in industry.	
IS: 3043-1991	Code or Practice for Indexing and Storage Of Drill Cores.	
IS: 4091-1987	Code of Practice for Design and Construction Of Foundations for Transmission Line Towers and Poles.	
IS: 4434-1992	Code of Practice for in-situ Vane Shear Test for Soils.	ASTM D 2573/ ASTM D 4648
IS: 4453-1992	Code of Practice for Exploration by Pits, Trenches, Drifts and Shafts.	
IS: 4464-1990	Code of Practice for Presentation of Drilling Information and core Description in Foundation Investigation	
IS: 4968 - (Part-II) – 1992	Method for Subsurface sounding for soils, dynamic method using cone and Bentonite slurry	
IS: 5313-1989	Guide for Core Drilling Observations.	

Indian Standards(IS)	Title	International and Internationally Recognize Standard/Code
----------------------	-------	---

IS:6403-1990	Code of Practice for	
--------------	----------------------	--

	Diamond Core Drilling for Site Investigation for River Valley Projects.	
IS: 6935-1989	Method of Determination of water level in a Bore Hole.	
IS: 7422-1990	Symbols and Abbreviations for use in Geological Maps Sections and subsurface Exploratory Logs (Relevant Parts).	
IS:8009 (Part-I)-1993	Code of Practice for Calculation of Settlements of Foundations (Shallow Foundations subjected to symmetrical Vertical Loads).	
IS:8764-1991	Method of Determination of Point Load Strength Index of Rocks.	
IS: 9179-1991	Method of Determination of Unconfined compressive Strength of Rock Materials.	ASTM D 2938
IS: 9179-1991	Method of Preparation of Rock Specimen for Laboratory Testing.	ASTM D 4543
IS: 9259-1992	Specification for Liquid Limit apparatus.	ASTM D 4318
IS: 9640-1992	Specification for Split Spoon Sampler	ASTM D 1586
IS: 10050-1992	Method of Determination of Slake Durability Index of Rocks.	ASTM D 4644
IS: 11315- (Part-II)-1991	Description of Discontinuities in Rock Mass-Core Recovery	

## TESTS

Tests as indicated in this specification and as may be requested by the Owner, shall be conducted. There tests shall include but may not be limited to the following :

- a) Tests of undisturbed and disturbed samples
- Visual and engineering classification;
- Sleeve analysis and hydrometric analysis;

- Liquid, plastic and shrinkage limits;
- Specific gravity;
- Chemical analysis
- Swell pressure and free swell index determination
- Proctor compaction test.
- b) **Tests of undisturbed samples:**
  - Bulk density and moisture content;
  - Relative density (for sand),
  - Unconfined compression test;
  - Box shear test (for sand);
  - Tri-axial shear tests (depending on the type of soil and field conditions on undisturbed or remoulded samples):
    - i) Unconsolidated untrained;
    - ii) Consolidated drained test;
  - Consolidation.
- c) **Tests on rock samples**
  - Visual classification:
  - Moisture content, porosity and density:
  - Specific gravity;
  - Hardness
  - Stake durability;
  - Unconfined compression test (both saturated and at in-situ water content);
  - Point load strength index;
  - Deformability test (both saturated and dry samples)

## Annexure-I

SITC for River Crossing Work				
Description	Qty	Schedule Supply	Schedule Erecting	Total
River crossing using PC+6 EHT Tower	16	-	-	-
River crossing using UR+6 EHT Tower	6	-	-	-
River crossing using 14 Mtr H-Pole DP	22	-	-	-
<b>Total In Rs.</b>		-	-	-
<b>Total In Cr.</b>		-	-	-

## Annexure I

BoQ for PC +6 Tower (Span Length > 300 Mtr.)								
<b>1</b>	<b>Required Total Qty. of PC+6 Tower</b>	<b>No</b>	<b>16</b>					
<b>Supply of GIPC '+6' EHT Tower for River crossing including all types of materials, as per technical specification and scope of work.</b>								
Sl. No.	Description of items	UoM	Unit Qty. (A)	Total Qty. (A1)	BASIC PRICE PER UNIT (B)	18% GST Amount (C)	TOTAL PRICE PER UNIT ( In Rs) (D)= B+C	TOTAL PRICE FOR THE TENDER QUANTITY (E)= (A1 x D)
<b>1</b>	<b>GIPC '+6' Tower super structure G.I (Main + Extention +Stub + Template), as per technical specification and scope of work.</b>							
	i) PC Tower	MT	6.2	99.4		-	-	-
	ii) '+6' Mtr. Extention	MT	2.3	37.5		-	-	-
	iii) Template	MT	0.9	14.4		-	-	-
<b>2</b>	<b>GI Nut , Bolt &amp; Washer of different sizes, as per technical specification and scope of work.</b>				-			
	i) PC Tower	MT	0.3	5.4	-	-	-	-
	ii) '+6' Mtr. Extention	MT	0.1	1.8	-	-	-	-
<b>3</b>	<b>Supply of Conductor and Accessories, as per technical specification and scope of work.</b>				-			
	i 232 mm2 AAAC, as per technical specification and scope of work.	Km	1.9	29.6		-	-	-
	ii Earth wire 7/1.5 G.I, as per technical specification and scope of work.	Km	0.5	8.0		-	-	-
	iii Double tension Hardware Fittings suitable for Conductor size.	Set	12	192		-	-	-
	iv Disc insulator (B&S) 120 KN polymer type.	No's.	24	384		-	-	-
	v Tension fittings suitable for Earth wire.	Set	2	32		-	-	-
	vi. Vibration damper suitable for earth wire	No's.	2	32		-	-	-
	vii. Vibration damper suitable for conductor size.	No's.	12	192		-	-	-
	viii Copper flexible bond	No's.	1	16		-	-	-
	ix Phase Plate (R,Y,B)	Set	6	96		-	-	-
	x GI Tower Number Plate	No's.	2	32		-	-	-
	xi Circuit Plate	No's.	2	32		-	-	-
	xii Earthing Device & Associated Accessories (Heavy duty GI Perforated Pipe of ID=40mm & OD=50mm with 3000mm long for treated Earth Pit), as per technical specification and scope of work.	No's.	2	32		-	-	-
	xiii Earthing Conductor: 50X6 mm (2.4Kg./Mtr.) GI Flat for Raiser from the burial earth mat to equipment, structure etc), as per technical specification and scope of work.	KG	100	1600		-	-	-
	xiv GI Danger Board	No's.	2	32		-	-	-
	xv Bird Guard	No's.	12	192		-	-	-
	xvi Anticlimbing Device (G.I)	KG	106	1690		-	-	-
	xvii Loop Connector	No's.	6	96		-	-	-
<b>Total of Supply Work</b>								
.	<b>Erection, Testing &amp; Commissioning of Materials of GIPC '+6' EHT Tower for River crossing including Civil supply all types of materials, as per technical specification and scope of work.</b>							
Sl. No.	Description of items	UoM	Unit Qty. (A)	Total Qty. (A1)	BASIC PRICE PER UNIT (B)	18% GST Amount (C)	TOTAL PRICE PER UNIT ( In Rs) (D)= B+C	TOTAL PRICE FOR THE TENDER QUANTITY (E)= (A1 x D)



<b>1</b>	<b>GI PC '+6' Tower super structure G.I (Main + Extention +Stub + Template), as per technical specification and scope of work.</b>							
i)	PC Tower	MT	<b>6.2</b>	<b>99.4</b>		-	-	-
ii)	'+6' Mtr. Extention	MT	<b>2.3</b>	<b>37.5</b>		-	-	-
iii)	Template	MT	<b>0.9</b>	<b>14.4</b>		-	-	-
<b>2</b>	<b>GI Nut , Bolt &amp; Washer of different sizes, as per technical specification and scope of work.</b>							
i)	PC Tower	MT	<b>0.3</b>	<b>5.4</b>		-	-	-
ii)	'+6' Mtr. Extention	MT	<b>0.1</b>	<b>1.8</b>		-	-	-
<b>3</b>	<b>Erection, Testing &amp; Commissioning of Materials of Conductor and Accessories, as per technical specification and scope of work.</b>							
i	232 mm2 AAAC, as per technical specification and scope of work.	Km	<b>1.9</b>	<b>29.6</b>		-	-	-
ii	Earth wire 7/1.5 G.I, as per technical specification and scope of work.	Km	<b>0.5</b>	<b>8.0</b>		-	-	-
iii	Double tension Hardware Fittings suitable for Conductor size.	Set	<b>12</b>	<b>192</b>		-	-	-
iv	Disc insulator (B&S) 120 KN polymer type.	No's.	<b>24</b>	<b>384</b>		-	-	-
v	Tension fittings suitable for Earth wire.	Set	<b>2</b>	<b>32</b>		-	-	-
vi.	Vibration damper suitable for earth wire	No's.	<b>2</b>	<b>32</b>		-	-	-
vii.	Vibration damper suitable for conductor size.	No's.	<b>12</b>	<b>192</b>		-	-	-
viii	Copper flexible bond	No's.	<b>1</b>	<b>16</b>		-	-	-
ix	Phase Plate (R,Y,B)	Set	<b>6</b>	<b>96</b>		-	-	-
x	GI Tower Number Plate	No's.	<b>2</b>	<b>32</b>		-	-	-
xi	Circuit Plate	No's.	<b>2</b>	<b>32</b>		-	-	-
xii	Earthing Device & Associated Accessories (Heavy duty GI Perforated Pipe of ID=40mm & OD=50mm with 3000mm long for treated Earth Pit), as per technical specification and scope of work.	No's.	<b>2</b>	<b>32</b>		-	-	-
xiii	Earthing Conductor: 50X6 mm (2.4Kg./Mtr.) GI Flat for Raiser from the burial earth mat to equipment, structure etc), as per technical specification and scope of work.	KG	<b>100</b>	<b>1600</b>		-	-	-
xiv	GI Danger Board	No's.	<b>2</b>	<b>32</b>		-	-	-
xv	Bird Guard	No's.	<b>12</b>	<b>192</b>		-	-	-
xvi	Anticlimbing Device (G.I)	KG	<b>106</b>	<b>1690</b>		-	-	-
xvii	Loop Connector	No's.	<b>6</b>	<b>96</b>		-	-	-
<b>4</b>	<b>Civil Work for PC '+6' EHT Tower, as per technical specification and scope of work.</b>							
i	Detail Survey of lines profile plotting, spotting and marking, as per technical specification and scope of work.	No's.	<b>1</b>	<b>16</b>		-	-	-

ii	Soil Investigation, Design, Egg., Including Report submission and approval.	No's	<b>1</b>	<b>16</b>		-	-	-
iii	Levelling and Backfilling to prepare required land.	Cum	<b>50</b>	<b>800</b>		-	-	-
iv	Excavation in all type soil and rocks and back filling (back filling shall be done in layers of 500mm sprinkling of water and compaction thereafter and disposed of excess quantity of excavated soil at suitable place after back filling), & if required for filling the foundation, borrowed earth/murum/sand shall be brought for filling and compaction, including supply of sand, all T&P, labour as required.							
iv.i	Soft and loose soil	Cum	<b>50</b>	<b>800</b>		-	-	-
v	Boring for under reamed cast in situ piling with bentonite showing for stabilisation of bore:- Pile diameter (1200 MM) and approximate length of the bore is 15 (12mtr till FGL nad 3mtr above FGL) Mtrs BY DMC method as per approved drawing.	Mtr. length	<b>36</b>	<b>576</b>		-	-	-
vi	Supply of all materials like cement, steel, all coarse aggregates, fine aggregates and making pile foundations of the required Tower foundation, including supply of all materials,labours and T&P as per specification in the RCC :1:1:2 (Grade M-25.) (with cost of cement and without steel)	Cum	<b>41</b>	<b>656</b>		-	-	-
vii	Steel of different size(as per design) -32mm pile & ring 12mm)with cutting,bending,binding in position of M.S.Rod for reinforcement of foundation concret of pile of towers including supply of binding wire. (With supply of steel rod (TATA/RINL/SAIL make)).Ring at every 200mm.	MT	<b>7</b>	<b>112</b>		-	-	-
viii	Supply and putting of MS liner of 6mm thickness and 1000mm dia as per approved drawing and as per instruction of engineer in charge.	MT	<b>8</b>	<b>128</b>		-	-	-
ix	Pile riser, cap, tie-beam with RCC: 1:1.5:3 (Grade M-20) , including supply of all materials like Cement, coarse and fine aggregates,shuttering and supply of labours, de-watering,proper curing of the foundations/concrete and T&P in line with the Specification and as per direction of Engineer in Charge. (with cost of cement and without steel)	Cum	<b>20</b>	<b>320</b>		-	-	-
x	Steel of different size(as per design) with cutting,bending,binding in position of M.S.Rod for reinforcement of foundation concret of pile riser, cap and tie beam including supply of binding wire. (With supply of steel rod (TATA/RINL/SAIL make))	MT	<b>0.5</b>	<b>8.0</b>		-	-	-
xi	Design, Engineering, Providing and laying of plain cement concrete (PCC 1:3:6) of grade M10 with approved quality coarse aggregates (Nominal size 12mm to 20mm), fine aggregates, cement in tower foundation as blind layer inclusive of labour charges for concrete mixing & curing. This includes supply of all labourers, T&P and dewatering wherever required as per Technical specification and instruction of Engineer In charge.(With Cement)	Cum	<b>1.5</b>	<b>24.0</b>		-	-	-
xii	Shoring And Shuttering required in wet or special locations with supply of all materials, T&P and Labour.(Required for riser works above ground level)	Sq.Mtr	<b>72.0</b>	<b>1152.0</b>		-	-	-

Total of Erection & Civil Services Works
--

-
---

BoQ for UR +6 Tower (Span Length > 550 Mtr.)								
1	Required Total Qty. of UR+6 Tower	No	6					
Supply of GI UR '+6' EHT Tower for River crossing including all types of materials, as per technical specification and scope of work.								
Sl. No.	Description of items	UoM	Unit Qty. (A)	Total Qty. (A1)	BASIC PRICE PER UNIT (B)	18% GST Amount (C)	TOTAL PRICE PER UNIT ( In Rs) (D)= B+C	TOTAL PRICE FOR THE TENDER QUANTITY (E)= (A1 x D)
1	GI UR '+6' Tower super structure G.I (Main + Extention +Stub + Template), as per technical specification and scope of work.				-			
i)	UR Tower	MT	13.6	81.5		-	-	-
ii)	'+6' Mtr. Extention	MT	4.2	25.5		-	-	-
iii)	Template	MT	1.5	9.1		-	-	-
2	GINut , Bolt & Washer of different sizes, as per technical specification and scope of work.				-			
i)	UR Tower	MT	2.3	13.7		-	-	-
ii)	'+6' Mtr. Extention	MT	0.6	3.5		-	-	-
3	Supply of Conductor and Accessories, as per technical specification and scope of work.				-			
i	232 mm2 AAAC, as per technical specification and scope of work.	Km	3.4	20.4		-	-	-
ii	Earth wire 7/1.5 G.I, as per technical specification and scope of work.	Km	0.8	4.5		-	-	-
iii	Double tension Hardware Fittings suitable for Conductor size.	Set	12	72		-	-	-
iv	Disc insulator (B&S) 120 KN polymer type.	No's.	24	144		-	-	-
v	Tension fittings suitable for Earth wire.	Set	2	12		-	-	-
vi.	Vibration damper suitable for earth wire	No's.	2	12		-	-	-
vii.	Vibration damper suitable for conductor size.	No's.	12	72		-	-	-
viii	Copper flexible bond	No's.	1	6		-	-	-
ix	Phase Plate (R,Y,B)	Set	6	36		-	-	-
x	GI Tower Number Plate	No's.	2	12		-	-	-
xi	Circuit Plate	No's.	2	12		-	-	-
xii	Earthing Device & Associated Accessories (Heavy duty GI Perforated Pipe of ID=40mm & OD=50mm with 3000mm long for treated Earth Pit), as per technical specification and scope of work.	No's.	2	12		-	-	-
xiii	Earthing Conductor: 50X6 mm (2.4Kg./Mtr.) GI Flat for Raiser from the burial earth mat to equipment, structure etc), as per technical specification and scope of work.	KG	100	600		-	-	-
xiv	GI Danger Board	No's.	2	12		-	-	-
xv	Bird Guard	No's.	12	72		-	-	-
xvi	Anticlimbing Device (G.I)	KG	106	634		-	-	-
xvii	Loop Connector	No's.	6	36		-	-	-
<b>Total of Supply Work</b>								
.	Erection, Testing & Commissioning of Materials of GI UR '+6' EHT Tower for River crossing including Civil supply all types of materials, as per technical specification and scope of work.							
Sl. No.	Description of items	UoM	Unit Qty. (A)	Total Qty. (A1)	BASIC PRICE PER UNIT (B)	18% GST Amount (C)	TOTAL PRICE PER UNIT ( In Rs) (D)= B+C	TOTAL PRICE FOR THE TENDER QUANTITY (E)= (A1 x D)

<b>1</b>	<b>GI UR '+6' Tower super structure G.I (Main + Extention +Stub + Template), as per technical specification and scope of work.</b>							
i)	UR Tower	MT	<b>13.59</b>	<b>81.5</b>		-	-	-
ii)	'+6' Mtr. Extention	MT	<b>4.25</b>	<b>25.5</b>		-	-	-
iii)	Template	MT	<b>1.51</b>	<b>9.1</b>		-	-	-
<b>2</b>	<b>GI Nut , Bolt &amp; Washer of different sizes, as per technical specification and scope of work.</b>							
i)	UR Tower	MT	<b>2.28</b>	<b>13.7</b>		-	-	-
ii)	'+6' Mtr. Extention	MT	<b>0.59</b>	<b>3.5</b>		-	-	-
<b>3</b>	<b>Erection, Testing &amp; Commissioning of Materials of Conductor and Accessories, as per technical specification and scope of work.</b>							
i	232 mm2 AAAC, as per technical specification and scope of work.	Km	<b>3.40</b>	<b>20.4</b>		-	-	-
ii	Earth wire 7/1.5 G.I, as per technical specification and scope of work.	Km	<b>0.75</b>	<b>4.5</b>		-	-	-
iii	Double tension Hardware Fittings suitable for Conductor size.	Set	<b>12</b>	<b>72</b>		-	-	-
iv	Disc insulator (B&S) 120 KN polymer type.	No's.	<b>24</b>	<b>144</b>		-	-	-
v	Tension fittings suitable for Earth wire.	Set	<b>2</b>	<b>12</b>		-	-	-
vi.	Vibration damper suitable for earth wire	No's.	<b>2</b>	<b>12</b>		-	-	-
vii.	Vibration damper suitable for conductor size.	No's.	<b>12</b>	<b>72</b>		-	-	-
viii	Copper flexible bond	No's.	<b>1</b>	<b>6</b>		-	-	-
ix	Phase Plate (R,Y,B)	Set	<b>6</b>	<b>36</b>		-	-	-
x	GI Tower Number Plate	No's.	<b>2</b>	<b>12</b>		-	-	-
xi	Circuit Plate	No's.	<b>2</b>	<b>12</b>		-	-	-
xii	Earthing Device & Associated Accessories (Heavy duty GI Perforated Pipe of ID=40mm & OD=50mm with 3000mm long for treated Earth Pit), as per technical specification and scope of work.	No's.	<b>2</b>	<b>12</b>		-	-	-
xiii	Earthing Conductor: 50X6 mm (2.4Kg./Mtr.) GI Flat for Raiser from the burial earth mat to equipment, structure etc), as per technical specification and scope of work.	KG	<b>100</b>	<b>600</b>		-	-	-
xiv	GI Danger Board	No's.	<b>2</b>	<b>12</b>		-	-	-
xv	Bird Guard	No's.	<b>12</b>	<b>72</b>		-	-	-
xvi	Anticlimbing Device (G.I)	KG	<b>106</b>	<b>634</b>		-	-	-
xvii	Loop Connector	No's.	<b>6</b>	<b>36</b>		-	-	-
<b>4</b>	<b>Civil Work for UR '+6' EHT Tower, as per technical specification and scope of work.</b>							
i	Detail Survey of lines profile plotting, spotting and marking, as per technical specification and scope of work.	No's.	<b>1.00</b>	<b>6</b>		-	-	-
ii	Soil Investigation, Design, Egg., Including Report submission and approval.	No's	<b>1.00</b>	<b>6</b>		-	-	-
iii	Levelling and Backfilling to prepare required land.	Cum	<b>50.00</b>	<b>300</b>		-	-	-
iv	Excavation in all type soil and rocks and back filling (back filling shall be done in layers of 500mm sprinkling of water and compaction thereafter and disposed of excess quantity of excavated soil at suitable place after back filling), & if required for filling the foundation, borrowed earth/murum/sand shall be brought for filling and compaction, including supply of sand, all T&P, labour as required.							
iv.i	Soft and loose soil	Cum	<b>50.0</b>	<b>300.0</b>		-	-	-

v	Boring for under reamed cast in situ piling with bentonite showing for stabilisation of bore:- Pile diameter (1200 MM) and approximate length of the bore is 15 (12mtr till FGL nad 3mtr above FGL) Mtrs BY DMC method as per approved drawing.	Mtr. length	36.0	216.0		-	-	-
vi	Supply of all materials like cement, steel, all coarse aggregates, fine aggregates and making pile foundations of the required Tower foundation, including supply of all materials,labours and T&P as per specification in the RCC :1:1:2 (Grade M-25.) (with cost of cement and without steel)	Cum	41.0	246.0		-	-	-
vii	Steel of different size(as per design) -32mm pile & ring 12mm)with cutting,bending,binding in position of M.S.Rod for reinforcement of foundation concret of pile of towers including supply of binding wire. (With supply of steel rod (TATA/RINL/SAIL make)).Ring at every 200mm.	MT	6.5	39.0		-	-	-
viii	Supply and putting of MS liner of 6mm thickness and 1000mm dia as per approved drawing and as per instruction of engineer in charge.	MT	7.5	45.0		-	-	-
ix	Pile riser, cap, tie-beam with RCC: 1:1.5:3 (Grade M-20) , including supply of all materials like Cement, coarse and fine aggregates,shuttering and supply of labours, de-watering,proper curing of the foundations/concrete and T&P in line with the Specification and as per direction of Engineer in Charge. (with cost of cement and without steel)	Cum	20.0	120.0		-	-	-
x	Steel of different size(as per design) with cutting,bending,binding in position of M.S.Rod for reinforcement of foundation concret of pile riser, cap and tie beam including supply of binding wire. (With supply of steel rod (TATA/RINL/SAIL make))	MT	0.5	3.0		-	-	-
xi	Design, Engineering, Providing and laying of plain cement concrete (PCC 1:3:6) of grade M10 with approved quality coarse aggregates (Nominal size 12mm to 20mm), fine aggregates, cement in tower foundation as blind layer inclusive of labour charges for concrete mixing & curing. This includes supply of all labourers, T&P and dewatering wherever required as per Technical specification and instruction of Engineer In charge.(With Cement)	Cum	1.5	9.0		-	-	-
xii	Shoring And Shuttering required in wet or special locations with supply of all materials, T&P and Labour.(Required for riser works above ground level)	Sq.Mtr	72.0	432.0		-	-	-
<b>Total of Erection &amp; Civil Services Works</b>								<b>-</b>

BoQ for 33 KV 14Mtr. H-Pole DP With Isolator and 232sqmm AAA Conductor (Span Length < 100 Mtr.)								
1	Required Total Qty. of 33 KV DP With Isolator	No	22					
Supply of 33 KV 14Mtr. H-Pole DP With Isolator for River crossing including all types of materials, as per technical specification and scope of work.								
Sl. No.	Description of items	UoM	Qty. (A)	Total Qty. (A1)	BASIC PRICE PER UNIT (B)	18% GST Amount (C)	TOTAL PRICE PER UNIT ( In Rs) (D)= B+C	TOTAL PRICE FOR THE TENDER QUANTITY (E)= (A1 x D)
1	14 Mtr. Long H-Pole	No	2	44		-	-	-
2	Top Channel 100X50X6mm, 9.56 KG/Mtr., each channel length 4.3 mtr., 2 no's channel required =( 2x9.56x4.3)	KG	82.2	1809		-	-	-
3	Fish Plate 50x6 mm., 2.36 kg/Mtr., each 0.280 mtr. length, 6 no's required =( 6x2.36x0.280)	KG	4.0	87		-	-	-
4	Insulator Support Cahnnel 75X40X 4.8mm., 7.14KG/Mtr., each channel length 4.3 Mtr., 1 no's channel required =( 1x7.14x4.3)	KG	30.7	675		-	-	-
5	Isolator Support Cahnnel 75X40X 4.8mm., 7.14KG/Mtr., each channel length 4.3 Mtr., 2 no's channel required =( 2x7.14x4.3)	KG	61.4	1351		-	-	-
6	Double Pole Belting Channel 75X40X 4.8mm., 7.14KG/Mtr., each channel length 4.3 Mtr., 4 no's channel required =( 4x7.14x4.3)	KG	122.8	2702		-	-	-
7	50x50x6mm.GI Bracing Angle, 4.5Kg./mtr., each angle length 4.927 mtr., 4 nos angle required = (4*4.5*4.927)	KG	88.7	1951		-	-	-
8	Isolator Operating Down Pipe Support Cahnnel 75X40X 4.8mm., 7.14KG/Mtr., each channel length 0.8 Mtr., 1 no's channel required =( 1x7.14x0.8)	KG	5.7	126		-	-	-
9	Down Pipe Diagonal Support Angle, 4.5Kg./mtr., each angle length 0.388mtr., 1 nos angle required = (1*4.5*0.388)	KG	1.7	38		-	-	-
10	Down Pipe Base Support Angle, 4.5Kg./mtr., each angle length 0.34mtr., 1 nos angle required = (1*4.5*0.340)	KG	1.5	34		-	-	-
11	Isolator Support Side Cahnnel 100X50X6mm, 9.56 KG/Mtr., each channel length 0.5 mtr., 2 no's channel required =( 2x9.56x0.5)	KG	9.6	210		-	-	-
12	Danger Plate, 2 no's.	No.	2	44		-	-	-
13	Back Clamp for danger Plate 25X3 mm. flat, 0.59Kg/Mtr. Flat of 0.510mtr length 2 no's = (2x0.59x0.510)	KG	0.6018	13		-	-	-
14	H.T. Stay clamp, 50x8 mm. flat, 3.14Kg/Mtr., 0.511 Mtr. Length, 2 no's qty. required ( 1 Pair)	Pair	2	44		-	-	-
15	H.T. Stay set (Complete )	Set	2	44		-	-	-
16	H.T. Stay Insulator Type-C (2 No's.)	No.	4	88		-	-	-
17	7/8 SWG Stay Wire 15kg /stay	K.g.	30	660		-	-	-
18	Gi Pipe Earthing 40mm. 3 Mtr. Long	No.	2	44		-	-	-
19	50x6mm GI Flat for earthing, 2.36kg/mtr., (15 Mtr. For L.A, 4 Mtr for Isolator Body, 2.5 mtr. For mesh formation and 2.5 mtr. For raising)= 24x2.36	KG	56.6	1246		-	-	-
20	GI barbed wire anticlimbing device 3 Kg. Per support	Kg	6	132		-	-	-
21	Back Clamp for anticlimbing device 25X3 mm. flat, 0.59Kg/Mtr. Flat of 0.510mtr length 8 no's = (8x0.59x0.510)	KG	2.4	53		-	-	-
22	232 mm2 AAAC, as per technical specification and scope of work.	Km	0.3	6.8		-	-	-
23	33 KV 1250 AMP Double break (Turn & twist center rotating) isolator without earth switch with PI(Polymer)	Set	1	22		-	-	-
24	33KV pin insulator polymer	No.	3	66		-	-	-
25	H W fitting(B&S) 90KN,4 Bolt	No.	6	132		-	-	-

26	Disc insulator (B&S) 90 KN polymer	No.	6	132		-	-	-
27	Wedge Connector for 232sqmm conductor	No.	6	132		-	-	-
28	GI Nut , Bolt & Washer of different sizes (22.15 Kg each DP with Isolator)	K.g.	22.2	487		-	-	-
29	Black Paint	Ltr	1	22		-	-	-
30	Yellow Colour Paint for Background	Ltr	2	44		-	-	-
<b>Total of Supply Work</b>								-
<b>Erection, Testing &amp; Commissioning of Materials of 33 KV 14Mtr. H-Pole DP With Isolator for River crossing including Civil supply all types of materials, as per technical specification and scope of work.</b>								
Sl. No.	Description of items	UoM	Unit Qty. (A)	Total Qty. (A1)	BASIC PRICE PER UNIT (B)	18% GST Amount (C)	TOTAL PRICE PER UNIT ( In Rs) (D)= B+C	TOTAL PRICE FOR THE TENDER QUANTITY (E)= (A1 x D)
1	14 Mtr. Long H-Pole	No	2	44		-	-	-
2	Top Channel 100X50X6mm, 9.56 KG/Mtr., each channel length 4.3 mtr., 2 no's channel required =( 2x9.56x4.3)	KG	82.2	1809		-	-	-
3	Fish Plate 50x6 mm., 2.36 kg/Mtr., each 0.280 mtr. length, 6 no's required = (6x2.36x0.280)	KG	4.0	87		-	-	-
4	Insulator Support Cahnnel 75X40X 4.8mm., 7.14KG/Mtr., each channel length 4.3 Mtr., 1 no's channel required =( 1x7.14x4.3)	KG	30.7	675		-	-	-
5	Isolator Support Cahnnel 75X40X 4.8mm., 7.14KG/Mtr., each channel length 4.3 Mtr., 2 no's channel required =( 2x7.14x4.3)	KG	61.4	1351		-	-	-
6	Double Pole Belting Channel 75X40X 4.8mm., 7.14KG/Mtr., each channel length 4.3 Mtr., 4 no's channel required =( 4x7.14x4.3)	KG	122.8	2702		-	-	-
7	50x50x6mm.GI Bracing Angle, 4.5Kg./mtr., each angle length 4.927 mtr., 4 nos angle required = (4*4.5*4.927)	KG	88.7	1951		-	-	-
8	Isolator Operating Down Pipe Support Cahnnel 75X40X 4.8mm., 7.14KG/Mtr., each channel length 0.8 Mtr., 1 no's channel required =( 1x7.14x0.8)	KG	5.7	126		-	-	-
9	Down Pipe Diagonal Support Angle, 4.5Kg./mtr., each angle length 0.388mtr., 1 nos angle required = (1*4.5*0.388)	KG	1.7	38		-	-	-
10	Down Pipe Base Support Angle, 4.5Kg./mtr., each angle length 0.34mtr., 1 nos angle required = (1*4.5*0.340)	KG	1.5	34		-	-	-
11	Isolator Support Side Cahnnel 100X50X6mm, 9.56 KG/Mtr., each channel length 0.5 mtr., 2 no's channel required =( 2x9.56x0.5)	KG	9.6	210		-	-	-
12	Danger Plate, 2 no's.	No.	2	44		-	-	-
13	Back Clamp for danger Plate 25X3 mm. flat, 0.59Kg/Mtr. Flat of 0.510mtr length 2 no's = (2x0.59x0.510)	KG	0.6	13		-	-	-
14	H.T. Stay clamp, 50x8 mm. flat, 3.14Kg/Mtr., 0.511 Mtr. Length, 2 no's qty. required ( 1 Pair)	Pair	2	44		-	-	-
15	H.T. Stay set (Complete )	Set	2	44		-	-	-
16	H.T. Stay Insulator Type-C (2 No's.)	No.	4	88		-	-	-
17	7/8 SWG Stay Wire 15kg /stay	K.g.	30	660		-	-	-
18	GI Pipe Earthing 40mm. 3 Mtr. Long	No.	2	44		-	-	-
19	50x6mm GI Flat for earthing, 2.36kg/mtr., (15 Mtr. For L.A, 4 Mtr for Isolator Body, 2.5 mtr. For mesh formation and 2.5 mtr. For raising)= 24x2.36	KG	56.6	1246		-	-	-
20	GI barbed wire anticlimbing device 3 Kg. Per support	Kg	6	132		-	-	-
21	Back Clamp for anticlimbing device 25X3 mm. flat, 0.59Kg/Mtr. Flat of 0.510mtr length 8 no's = (8x0.59x0.510)	KG	2.4	53		-	-	-
22	232 mm2 AAAC, as per scope of work.	Km	0.3	6.8		-	-	-



23	33 KV 1250 AMP Double break (Turn & twist center rotating) isolator without earth switch with PI(Polymer)	Set	1	22	-	-	-
24	33KV pin insulator polymer	No.	3	66	-	-	-
25	H W fitting(B&S) 90KN,4 Bolt	No.	6	132	-	-	-
26	Disc insulator (B&S) 90 KN polymer	No.	6	132	-	-	-
27	Wedge Connector for 232sqmm conductor	No.	6	132	-	-	-
28	GI Nut , Bolt & Washer of different sizes (22.15 Kg each DP with Isolator)	K.g.	22.2	487	-	-	-
29	Black Paint	Ltr	1	22	-	-	-
30	Yellow Colour Paint for Background	Ltr	2	44	-	-	-
31	<b>Civil Work for 33 KV 14Mtr. H-Pole DP With Isolator, as per technical specification and scope of work.</b>						
i	Excavation of Earth for 14 Mtr. long poles pit. (1000mm X 500mm X 2300mm) = 1.15 Cu.mtr.), as per technical specification and scope of work.	Cum	2.3	51	-	-	-
ii	Concreting ratio 1:1.5:3 (500mmX500mmX2300mm) = 0.575Cu.mtr	Cu.mtr	1.2	25	-	-	-
iii	Couping ratio 1:1.5:3 with dimension (500X500X450)= 0.1125 Cu mtr	Cu.mtr	0.2	5	-	-	-
iv	Fixing of 33KV line Complete stay set, including excvaton, supply of 0.5Cum cement concrete foundation 1:2:4 size (500mmx500mmx800mm) using 20mm BHG metal with all labour and material (Excavation of earth will be done of size 500X500X1500 mm.)	No.	2	44	-	-	-
v	Making of earth chamber with brick masonry (1:5) , PCC (1:4:8) and with 50mm thick RCC Slab (with 8mm rod) cover for earth pit of size 450mmX450mm X600 mm depth as per direction of Engg in Charge.	No.	2	44	-	-	-
<b>Total of Erection &amp; Civil Services Works</b>							-
<b>Total of Supply, Erection &amp; Civil Services Works</b>							-

TPCODL		APPROVED MANUFACTURER-DISTRIBUTOR LIST OF TPCODL ( For New Connection work only) Updated Upto 10.01.2024				Valid Till : 31.01.2024
Sr. No	Description of Material/ Equipment	Manufacturer Name	Contact Address	Contact Person	Contact No.	Email ID
1	HT Outdoor Type Vacuum Circuit Breaker(VCB)	M/s CG Power & Industrial Solutions Ltd, Maharashtra	A-3, MIDC, Pandavleni, Ambad, Nashik, Maharashtra	Mr. Gaurav Dhikale	9370417581	gaurav.dhikale@cgglobal.com
		M/s ABB INDIA Ltd, Maharashtra	Plot No.34, MIDC Industrial Area,Satpur, Nashik, Maharashtra	Mr. Saibal Majumdar	9007000365	saibal.majumder@in.abb.com
2	HT Indoor Type Vacuum Circuit Breaker(VCB)	M/s ABB INDIA Ltd, Maharashtra	Plot No.34, MIDC Industrial Area,Satpur, Nashik, Maharashtra	Mr. Saibal Majumdar	9007000365	saibal.majumder@in.abb.com
		M/s Schneider Electric Infrastructure Ltd,Bhubaneswar	14,Forest Park,Bhubaneswar-751009	Mr. Girija Patnaik	9937062964	girija.patnaik@schneiderelectric.com
3	33 kV Ring Main Unit (With Metering)	M/s Lucy Electric India Pvt Ltd, Maharashtra	H-21, MIDC Ambad, Nashik, Maharashtra	Mr. Pratap Throat	9960867888	Pratap.Thorat@lucyelectric.com
		M/s ABB INDIA Ltd, Maharashtra	Nashik, Maharashtra	Mr. Saibal Majumdar	9007000365	saibal.majumder@in.abb.com
4	33 kV Ring Main Unit (Without Metering)	M/s Lucy Electric India Pvt Ltd, Maharashtra	H-21, MIDC Ambad, Nashik, Maharashtra	Mr. Pratap Throat	9960867888	Pratap.Thorat@lucyelectric.com
		M/s ABB INDIA Ltd, Maharashtra	Plot No.79,Street No. 17, MIDC Industrial Area,Satpur, Nashik, Maharashtra	Mr. Saibal Majumdar	9007000365	saibal.majumder@in.abb.com
		M/s SIEMENS Ltd, Goa	L-6,Verna Industrial Estate, Verna Salcete, Goa	Mr. Utpal Roy	9748255175	utpal.roy@siemens.com
		M/s Partha Electricals, Gujrat	E-113, Manjusar G.I.D.C Savli, Industrial Estate, Vadodara, Gujarat	Mr. Jignesh Patel	9879106471	jignesh.patel@parthelectricals.in
5	11 kV Ring Main Unit (With Metering)	M/s Lucy Electric India Pvt Ltd, Maharashtra	H-21, MIDC Ambad, Nashik, Maharashtra	Mr. Pratap Throat	9960867888	Pratap.Thorat@lucyelectric.com
		M/s ABB INDIA Ltd, Maharashtra	Plot No.79,Street No. 17, MIDC Industrial Area,Satpur, Nashik, Maharashtra	Mr. Saibal Majumdar	9007000365	saibal.majumder@in.abb.com
6	11 kV Ring Main Unit (Without Metering)	M/s Lucy Electric India Pvt Ltd, Maharashtra	H-21, MIDC Ambad, Nashik, Maharashtra	Mr. Pratap Throat	9960867888	Pratap.Thorat@lucyelectric.com
		M/s ABB INDIA Ltd, Maharashtra	Plot No.79,Street No. 17, MIDC Industrial Area,Satpur, Nashik, Maharashtra	Mr. Saibal Majumdar	9007000365	saibal.majumder@in.abb.com
		M/s SIEMENS Ltd, Goa	L-6,Verna Industrial Estate, Verna Salcete, Goa	Mr. Utpal Roy	9748255175	utpal.roy@siemens.com
		M/s Eaton Power Quality Pvt Ltd,Pondichery	EVR Street, Sedarapet, Pondicherry	Mr. Pritam Maiti Mr. Swarnadip Mukherjee	7291029069 9007026607	PRITAMKMaiti@eaton.com swarnadipmukherjee@eaton.com
		Ms C-Sec Technologies Pvt Ltd.	Plot no-10,Sec-11,II E Sidcul, Ranipur Haridwar-249403	Mr. Suhas Aapte	8291706861	sameer.apte@c-sec.co.in
		M/s Partha Electricals, Gujrat	E-113, Manjusar G.I.D.C Savli, Industrial Estate, Vadodara, Gujarat	Mr. Jignesh Patel	9879106471	jignesh.patel@parthelectricals.in
7	HT 630 KVA CSS	M/s Sudhir Power, Haryana	Plot No. 92, Sector - 8, IMT Manesar, Gurgaon – 122 050, Haryana, India	Mr. Amit S Rana	7906917260	amitsrana@sudhirpower.com
		M/s Partha Electricals, Gujrat	E-113, Manjusar G.I.D.C Savli, Industrial Estate, Vadodara, Gujarat	Mr. Jignesh Patel	9879106471	jignesh.patel@parthelectricals.in

TPCODL		APPROVED MANUFACTURER-DISTRIBUTOR LIST OF TPCODL ( For New Connection work only) Updated Upto 10.01.2024				Valid Till : 31.01.2024
Sr. No	Description of Material/ Equipment	Manufacturer Name	Contact Address	Contact Person	Contact No.	Email ID
	TRANSFORMER ( All are BIS Level-2 (Old) / Level-1(As per Ammdt.4/2021) except other wise mentioned)					
	11/0.4KV DTR: 25,63,100,250,500 KVA 11/0.240KV DTR: 16 KVA	M/s Alfa Transformers Ltd,Bhubaneswar	Plot No.3337,Mancheswar Industrial Estate,Rasulgarh,Bhubaneswar,Odisha	Mr.Debasish Das	9437007700	debasis.das@alfa.in sales@alfa.in info@alfa.in
	11/0.4KV DTR: 25,63,100,250,500 KVA	M/s Orissa Transformers Pvt. Ltd.,Bhubaneswar	S3/73, Sector-A, Zone-B, Mancheswar Industrial Estate, Bhubaneswar-751010	Mr. Jiban Kumar Badu	9437307224 8328838815	otpljkb@gmail.com
	11/0.4KV DTR: 25,63,100,250,500 KVA	M/s Suvam Transmission Pvt Ltd, Bhubaneswar	Kesura, Jharpada, Bhubaneswar,Odisha	Mr.Harihar Parida	9090968905	stpl.bhubaneswar@gmail.com
	11/0.4KV DTR: 25,63,100,250 KVA 11/0.240KV DTR: 16 KVA	M/s Gram Tarang Employability Training Services Pvt Ltd, Khurda	Jatani, Khurda,Odisha	Mr. Manoj Kumar Nayak	9338123532	manoj.nayak@gramtarang.org.in
	11/0.4KV DTR: 25,63,100,250 & 500 KVA	M/s Orissa Engineering Udyog Pvt. Ltd,Jagatpur,Cuttack	At-S3/17,Jagatpur Industrial Estate,Phase-3,Jagatpur,Cuttack,Odisha	Er. W. Z. Khan	9861050293 9238412786	oeu_wzk2003@yahoo.com oeu.groups@gmail.com
	11/0.4KV DTR: 25,63,100,250 KVA	M/s Power Line Transformer Pvt Ltd,Bhubaneswar	Mancheswar,Bhubaneswar	Mr.K C Mishra	9437025806	powerline.bbsr@gmail.com
	11/0.4KV DTR: 25,63,100 KVA 11/0.240KV DTR: 16 KVA	M/s Powertech & Technology,Cuttack	IDCO Plot No.80/O,Phase-III ,New I.E,Jagatpur,Cuttack,Odisha	Mr.Debasis Bhoi	9437120176 9437339639	powertechtechnology25@gmail.com
	11/0.4KV DTR: 25,63,100,250 KVA 11/0.240KV DTR: 16 KVA	M/s Om Sai Transformer Pvt Ltd,Cuttack	D2/2 & D2/3 , Old Industrial Estate,Jagatpur,Cuttack	Mr.Bijay Kishore Nanda	9861062611 9437312568	ommsaitransformers2007@gmail.com
	11/0.4KV DTR: 25,63,100 KVA	M/s Apolo Transformer,Cuttack	Balisahi,Khapuria(OGP),Cuttack	Mr.Samir Mohan Das	9439551221 9437027885	apolotransformer@gmail.com
	11/0.4KV DTR: 25,63,100 KVA	M/s Genmart Transformer,Cuttack	Imam Nagar,Cuttack	Mr.B.P.Mishra	9716164645 8368852984	genmartctc2019@gmail.com
	11/0.4KV DTR: 25,63,100 KVA	M/s Akhandalamani Electricals & Constructions, Cuttack	Kuspangi,Cuttack, Odisha	Mr. Prabhat Kumar Rout	9438873224	pravat@aecinfrastructure.com
	11/0.4KV DTR: 25,63,100 ,500 KVA 11/0.4KV DTR: 250 KVA(EEL-3(Old) / EEL-2(As per Ammdt.4/2021) 11/0.240KV DTR: 16 KVA	M/s Skylight Transformer,Cuttack	Plot No.51,Immam Nagar, Salipur, Bhairapur, Jagatpur, Cuttack, Odisha	Mr.C K Pradhan	9437644889 9337269896	skylight.odisha@gmail.com
	11/0.4KV DTR: 25,63,100,250,500 KVA	M/s J B Electricals,Dhenkanal	31 & 33 Kathagada,Anand Nagar,Dhenkanal	Mr.Ananta Charan Baral	8895353125 9861163657	jb.electricals14@yahoo.in anantacharanbaral2019@gmail.com
	11/0.4KV DTR: 25,63 & 250 KVA	M/s Siva Transformer,Talcher,Angul	At- Remuan, Po- Hatatota, Talcher , Dist-Angul(Odisha) Pin-759100	Mr.Siva Sekhar Sahoo	9437040182, 7381040188	sivatransformer2013@gmail.com
	11/0.4KV DTR: 25,63,100,250,500 KVA 11/0.240KV DTR: 16 KVA	M/s Bright Transformers Pvt Ltd,Bhubaneswar	I51, Sector-A, Zone-B, Industrial Estate,Mancheswar,Bhubaneswar,Odisha	Mr.Trilochan Lenka Mr.Ajay Chhualsingh	9437317639 7609866088	btplbbsr10@gmail.com
	11/0.4KV DTR: 25,63,100,250 KVA	M/s Kapilas Transformers,Dhenkanal	At : Asanabahal, Po : Barada, Dist : Dhenkanal, Odisha	Mr. Bipin Bihari Nayak	9938501617 9439580031	kapilashtransformer14@gmail.com
	11/0.4KV DTR: 25,63,100,250 KVA 11/0.240KV DTR: 16 KVA	M/s Orissa Industrial Equipments Pvt. Ltd.,Bhubaneswar	Plot no S/72,Sec A, Zone A, Mancheswar Industrial State ,Bhubaneswar,Odisha	Mr. Jiban Kumar Badu	9437307224	oieplsb@gmail.com
	11/0.4KV DTR: 25,63,100 KVA	M/S Maa Tarini Electricals & Engineering,Cuttack	IDCO Plot No.50/O,Phase-III ,New I.E,Jagatpur,Cuttack,Odisha	Mr. S Mohapatra	8328920567	maatarinitransformer@gmail.com
	11/0.4KV DTR: 25,63,100 KVA	M/s Bijyanee Transformer, Dhenkanal	At-Banamaliprasad near DPS , Po- Dhenkanal, Dist-Dhenkanal(Odisha) Pin-759001	Mr.Niranjana Biswal	9437292435	bijayeenierprise@gmail.com
	11/0.4KV DTR: 25,63,100 KVA(EEL-3(Old) / EEL-2(As per Ammdt.4/2021) 11/0.4KV DTR: 250,500 KVA	M/s Care Transformer,Bhubaneswar	Plot No 211 (F), Sector- A, Zone -B, Mancheswar Industrial Estate, Bhubaneswar-751010, odisha	Mr.Amiya Ranjan Behera	9861140540	caretransformerbbsr@gmail.com
	11/0.4KV DTR: 25,63,100,500 KVA	M/s Konark Transformer Pvt. Ltd,Cuttack	Plot No 55,Phase-II, New Industrial Estate, Jagatpur, Cuttack,Odisha	Saheduzzaman Khan	9861592825	chandbabu.12@rediffmail.com
8	11/0.4KV DTR: 25,63,100,250 KVA	M/s Maa Ugratara Transformers Pvt Ltd, Khurda	Nizigarh,Kuhuri,Near Tangi,Dist-Khurda,Pin-752027	Mr.Subhasish Pattnaik	9853511278 9861058123	m.ugratara@gmail.com
	11/0.4KV DTR: 100 KVA	M/s Madni Power Transformer & Electricals, Puri	Plot no-920, Near UGS College,Sakhigopal,Puri,Pin-752014.	Mohammad Khan	9861212812	madnipower786@gmail.com
	11/0.4KV DTR: 100 KVA	M/s Lakheswar Transformer & Tradings,Cuttack	Plot No.1640/3340, Kuranga Sasan, Niali, Cuttack	Mr. Pravat Kumar Baral	9337737271 9437035666	ltt20199@gmail.com
	11/0.4KV DTR: 25,63,100,250,500KVA	M/s S K Electricals, Jajpur	Oupada,Panikoili,Jajpur,Odisha	Mr. Saroj Kumar Poi	9338710303	eskelectricals@gmail.com

TPCODL	APPROVED MANUFACTURER-DISTRIBUTOR LIST OF TPCODL ( For New Connection work only) Updated Upto 10.01.2024					Valid Till : 31.01.2024
Sr. No	Description of Material/ Equipment	Manufacturer Name	Contact Address	Contact Person	Contact No.	Email ID
	11/0.4KV DTR: 25,63,100,250 KVA	M/s Samleswari Transformers Pvt. Ltd.,Bhadrak	Baradeswar,Kenduapada,Bhadrak,Odisha	Mr. Sumit Jena	7008905880 9853574199	menterprises761@gmail.com
	11/0.4KV DTR: 25,63,100,250 & 500KVA 11/0.240KV DTR: 16 KVA	M/s Microtek Transformers Pvt Ltd, Balasore	Kuruda,(NH-5), Near Kuruda Flyover, Balasore	Mr. Rajiv Shah Mr. Alok Ranjan Mallick	9437066509 9439841872	menterprises761@gmail.com microtek_trans@yahoo.com
	11/0.4KV DTR: 25,63,100 KVA	M/s Fyaro Transformers, Balasore	S-2/10, Industrial Estate, Balasore, Odisha-756001	Mr. S. Acharya	9437061793 9437000919 7008372871	fyarotrans@gmail.com
	11/0.4KV DTR: 25,63,100 KVA	M/s SaiKrupa Transformers, Keonjhar	Tangarpalasa, Ghadaghadi Temple Road, Near Railway Over Bridge, Naranpur, Keonjhar,Odisha	Mr. Uday Kumar Sha	9437157746 7008800796	saikrupatransformers@rediffmail.com
	11/0.4KV DTR: 25,63,100 & 500 KVA	M/s KMR Transformers, Balasore	Plot No 20, Gadiamal, Bahal, Sergarh Balasore, Odisha 756060	Mr. Mahesh Kumar Modi	8917258551 9438590438	kmrtransformer@gmail.com
	11/0.4KV DTR: 25 & 63 KVA	M/s Jagannath Electricals, Bhadrak	At - Erein, Po - Charampa, Dist - Bhadrak	Mr. Madan Lal Agarwal	9437060421 7008605895	madanagarwal51@yahoo.com
	11/0.4KV DTR: 25,63,100,250 KVA	M/s. Lakshmi Transformer Electricals ,Agra	B-8, Site-A, UPSIDC, Sikandra, AGRA-282007	Mr. M.K Bhagel	9927395842 9927395037	lakshmi.transformers@gmail.com
	11/0.4KV DTR: 63,100,250,500 KVA	M/s Nucon Switchgears Pvt Ltd, Ludhiana	D-47, Phase-V, Focal Point, Ludhinana-141 010. (Pb.) India	Mr.Sushil Kumar	9988388387 9891915253	sushil@nucon.co.indavgup@gmail.com
	11/0.4KV DTR: 250,500 KVA	M/s SVASCA Industries Ltd, Haryana	48th Milestone, Delhi Mathura Road, Parithala, Palwal,Haryana-121102	Mr.S C Sharma	9811084747	info@svascaindustries.com
	11/0.4KV DTR: 25,63,100,500 KVA	M/s Synergy Power Equipment Pvt Ltd ,Jamshedpur	Road#17, Jawahar Nagar, Mango, Jamshedpur-831020 Jharkhand	Mrs. Sangeeta Yadav	7485093673	synergypower18@yahoo.com
	11/0.4KV DTR: 250,500 KVA	M/s Telawne Power Equipments Pvt Ltd , Mumbai	R-457, MIDC Rabale,Behind pipeline road,Thane Belapur Road, Navi Mumbai - 400 701	Mr.Aswini Kumar	8698703532	tender@telawne.com
	11/0.4KV DTR: 25,63,250,500 KVA 11/0.240KV DTR: 16,25 KVA	M/s Toshiba T& D Systems(India) Pvt Ltd, Telengana	Rudraram, Patancheru Mandal, Sangareddy District, Telangana-502329	Mr. T Dhanraj	9573377652	srinikhitha.durgempudi@toshiba-tdi.com mahesh.katepalli@toshiba-tdi.com
	11/0.4KV DTR: 25,63,100,500 KVA	M/s Viji Power Transformers Pvt Ltd, Bangalore	Plot No-21, Meheta Industrial Estate, Dasanapura Hobli, Bapagrama Post, Machohalli, Bangalore-560091	Mr.Dinakar B	9900111089 7829975506 7760171114	vijitechdinakar10@yahoo.co.in
	11/0.4KV DTR: 25,63,100,250,500 KVA	M/s Volt Tech Manufacturing Company Ltd, Tamilnadu	Survey No.212/1,212/2,313/3, Pillainakkam Village, Sriperumpudur Taluk, Kancheepuram,Tamilnadu	Mr. R Adalarasan	9360124618 9369361044	transformers@voltechgroup.com
	11/0.4KV DTR: 25,63,100,250 KVA	M/s Siliguri Electric Works Ltd, West Bengal	Khaprail Road,Matigara,Siliguri,Darjeeng,West Bengal	Mr. A Das	9733309977 3532530776	contact.sew@gmail.com
	11/0.4KV DTR: 100 KVA	M/s Marsons Energy Ltd, Jaipur	403, Paradise Garden, A-25 Tilak Nagar, Vidhyalaya Marg, Jaipur-302004	Mr. Kanheya Lal	9829111080 8005861581	info@marsons.co.in
	11/0.4KV DTR: 25,63,100 KVA	M/s Star Delta Transformers Ltd, Bhopal	92-A, Industrial Area Gobindapur, Bhupal-462023(M.P)	Mr. Aman Tiwari	9589436146	star.deltaeng@gmail.com
	11/0.4KV DTR: 100 KVA	M/s Tesla Power Equipments & Projects Pvt Ltd, Bhopal	Plot no.H-147 & I-147,Sector-H,Industrial Area,Govindpura,Bhopal	Mr. Hemant Malviya	9981419641	hemant@teslaindia.co
	11/0.4KV DTR: 25,63,100 KVA, 11/0.240KV DTR: 16 KVA	M/s Vardhman Electromech Pvt Ltd, Jaipur	F-674, Phase-II, RIICO Industrial Area,Sitapura, Jaipur,Rajasthan-302022	Mr. K. P. Shenu	9179320240	kp.shenu@vardhman.net
	11/0.4KV DTR: 25,63,100,250,500 KVA	M/s Jay Bee Industries	Village Batwal, Tehsil raipur Rani, Dist Panchkula -Haryana	Mr. Sunil Soni	9971001211	Nitesh.soni@rhineenergy.com
		M/s Rashtriya Electricals & Engineering Corporation Pvt Ltd,Ghaziabad	C-2-3,Sector-A-3,Tronica City, Ghaziabad,Uttar Pradesh	Mr.Sanjeev Goyal Mr.Lalit	8048409175 8860040606	lalit@rashtriyaelectrical.com
		M/s Hindustan Chemicals, Khurja, UP	NH-91,G.T Road,Near Telephone Exchange,Khurja,Uttar Pradesh-203131	Mr.Shomil Gupta	9690011869 9837057759	sales@hindustanchemicals.com
		M/s Hobb International,Howrah	Jalan Complex,Howrah,West Bengal	Mr.Pratik Hore Mr.Vedant Balasaria	8017733646 9830079313	
		M/s Scenario Powertech Pvt Ltd,Gujrat	Survey No.82/P.Gambhirpura,Vavdi-Harsol Road,Talod,Sabarkantha,Gujarat,India-383305	Mr.Ketul Patel Mr.Yashdip Patel	9925246612 9898137221	ketul@scenariopower.com scenario.power@gmail.com
			<b>Authorized Distributors:</b> 1. Ms Indian Power Industries, Cuttack,Odisha	Mr. BN Patra	9937091838	indianpower123@gmail.com

TPCODL		APPROVED MANUFACTURER-DISTRIBUTOR LIST OF TPCODL ( For New Connection work only) Updated Upto 10.01.2024				Valid Till : 31.01.2024
Sr. No	Description of Material/ Equipment	Manufacturer Name	Contact Address	Contact Person	Contact No.	Email ID
9	HT Polymer Pin & Disc Insulator	M/s Adinath Industries, Rajasthan	Plot No. E-45(G-2), RICCO Ind. Area,Khushkhera, Bhiwadi, Dist. Alwar, Rajasthan- 301019 (INDIA)	Mr.Arnab Mitra	9830195664	arnab.adinathindus@gmail.com
		M/s Prime Insulators Pvt Ltd, Gujarat	Ceramic Zone, Block no. 134/P2,Dalpur, TA Prantij, Sabarkantha, Gujarat, INDIA (383 120).	Mr.Mohan Krishna	9925237312 9879521374	info@primeinsulators.com, sales@primeinsulators.com
		M/s Imperial Porcelain Pvt Ltd, Rajasthan	E 247-248,248A, IGC Khara, Khara, Bikaner, Rajasthan, India - 334601	Mr. Anand Lahoti Mr.Mukesh Joshi	9001091705 9001091707	polymer@imperialceramics.in
		M/s Ele Chem Systems Pvt. Ltd, Punjab	Plot No:- 524-525, Phase - IX, Industrial Area, Mohali, Punjab-160062 ( India)	M/s Neha	8872080082	elesystems1@gmail.com elechemindia123@gmail.com
		M/s Prithvi Industries Pvt. Ltd., Howrah	PB Samaddar Industrial Area,Vill: Ruia, Mouza:Popatulia, 24 North Parganas, Kolkata, West Bengal-700119	Mr. Sanjib Kumar Pal	9438344128	inquiry.prithvi@gmail.com
		Authorized Distributors: 1. Ms Indian Metal Industries Nayabazar, Cuttack				dingal007@gmail.com
10	12KV, 10KA Polymeric Lighting Arrestor	M/s Elektrolites Power Pvt Ltd, Jaipur	E-148 to 150,RICCO Industrial Area,Bagru,Jaipur,Rajasthan-302007	Ms. Alisha Garg	8696948980	alisha.garg@elektrolites.com
		M/s ELPRO International Ltd, Pune	Near Chaphekar Chowk,Chinchwad Gaon, Opposite Annapurna Hotel, Pune,Maharashtra	Mr. Satish Kale	8879113397	mkt@elpro.co.in mkt.mov@elpro.co.in
		M/s New Aquaria Electeck Pvt. Ltd., Telangana	Plot No.30,Kucharam Industrial Park,Toopran,Mandal,Medak,Telangana	Mr.Karthik C Mr.Raghabendra	8806667604 9538880209	sales@newaquariaelecteck.com raghu@newaquariaelecteck.com
			Authorized Distributors: 1. M/s Indian Metal Industries, Cuttack 53, Dingal Badi, Cuttack, Gosala Road, PO-Nayabazar, Odisha	Mr. Samir Kumar Dingal Mr. Santanu Dingal	7008696247 9853786663	dingal007@gmail.com
		M/s LAMCO Industries Pvt Ltd, Hyderabad	B-38 39 & 40,Industrial Estate,Sanathnagar,Hyderabad, Andhra Pradesh-500018	Ms.Lavanya	8096080080	lavanya.g@lamcoindia.com info@lamcoindia.com
			A-16&17,Assisted Private Industrial Estate,Balanagar,Hyderabad,Telangana-500037	Mr.Prasanna	9666218445	sales@oblum.co.in technical@oblum.co.in prasanna@oblum.co.in
		M/s Raychem RPG Pvt Ltd., Gujarat	Kanjari,Jyoti Compound,Nr Halol GIDC,Panchmahal,Gujarat	Mr.Rahul Biswas Mr.Mehul Patel	9771427299 9724304622	rahul_biswas@raychemrpg.com
		M/s Rashtriya Electricals & Engineering Corporation Pvt Ltd,Ghaziabad, UP	C-2-3,Sector-A-3,Tronica City, Ghaziabad,Uttar Pradesh	Mr.Sanjeev Goyal Mr.Lalit	08048409175 8860040606	lalit@rashtriyaelectrical.com
		M/s Hindustan Chemicals,Khurja, UP	NH-91,G.T Road,Near Telephone Exchange,Khurja,Uttar Pradesh-203131	Mr. Shomil Gupta	9690011869 9837057759	sales@hindustanchemicals.com
		M/s Orange Power T&D Equipments(P) Ltd, Bangalore	# 2, SSI Area, 1st Cross,Rajaji Nagar,Bangalore, Karnataka	Mr. Chetan Bhurat	9980533011	sales@orangepower.co.in
M/s SHREE RADHE INDUSTRIES	Plot no -86, Alindra GIDC, Manjusar, Ta-Savli, Dist-Vadodara-391775, Mob: 9879978170	1. Mr. Anurag Jha	6351323319 9983520057	sales@shreeradheindustries.com		

TPCODL		APPROVED MANUFACTURER-DISTRIBUTOR LIST OF TPCODL ( For New Connection work only) Updated Upto 10.01.2024				Valid Till : 31.01.2024
Sr. No	Description of Material/ Equipment	Manufacturer Name	Contact Address	Contact Person	Contact No.	Email ID
11	30KV, 10KA Polymeric Lighting Arrestor	M/s Engineer Enterprise, Rajasthan	F-112, RIICO Industrial Area Extn.,Phase-2, Bagru, Jaipur, Rajasthan	Mr. Hari	8058191595	marketing@ceenterprise.in
		M/s Oblum Electrical Industries Pvt Ltd, Hyderabad	A-16&17,Assisted Private Industrial Estate,Balanagar,Hyderabad,Telangana-500037	Mr.Prasanna	9666218445	sales@oblum.co.in technical@oblum.co.in prasanna@oblum.co.in
		M/s New Aquaria Electeck Pvt. Ltd., Telangana	Plot No.30,Kucharam Industrial Park,Too pran,Mandal,Medak,Telangana	Mr.Karthik C Mr.Raghabendra	8806667604 9538880209	sales@newaquariaelecteck.com raghu@newaquariaelecteck.com
			1. M/s Indian Metal Industries, Cuttack 53, Dingal Badi, Cuttack, Gosala Road, PO-Nayabazar, Odisha	Mr. Samir Kumar Dingal Mr. Santanu Dingal	7008696247 9853786663	dingal007@gmail.com
			<b>Authorized Distributors:</b> 2. M/s Samal Industries, Khurda Plot No C/10 and 9/1 IID centre Industrial Estate Khurda	1. Mr. Prakash Samal	1. 9437231336	1. samalindustries1234@gmail.com
		M/s SHREE RADHE INDUSTRIES	Plot no -86, Alindra GIDC, Manjusar, Ta-Savli, Dist-Vadodara-391775, Mob: 9879978170	1. Mr. Anurag Jha	6351323319 9983520057	sales@shreeradheindustries.com
		M/s Orange Power T&D Equipments(P) Ltd, Bangalore	1 st Cross Small Scale Industrial Area, Rajajinagar, Bangalore -560010 Phone-23356615 .	Mr. Chetan Bhurat	9980533011	orange.power@rediffmail.com
12	11 KV Polymer type AB Switch	M/s Ultima Switchgears Ltd.,Noida	F-6/F-7,UPIIDC,Surajpur Industrial Area,Greater Noida,UP-201336	Mr.Vansh Parmar	9582221901 9953233568	vdp@ultimaswitchgear.com
		M/s High Tension Electrical Equipments Pvt. Ltd,Howrah	101, C Road, Belgachia, Dasnagar,Howrah, West Bengal	Mr.Kaushik Das	9831906005	comm1@hightension.in
		M/s Sigma Power Industries, Cuttack	Plot no-18, Low Laying Area, Industrial Estate, Khapuria, Madhupatna, Cuttack, 753010, Odisha	Mr. Debankar Biswal	9755550290	sigmapower2020@gmail.com
		M/s Samal Industries, Khurda	Plot No C/10 and 9/1 IID centre Industrial Estate Khurda	Mr. Prakash Samal	9437231336	samalindustries1234@gmail.com
		M/s Indian Power Industries, Cuttack	Jhikiria, 42 Mouza, Cuttack, Odisha- 754112	Mr. Bholanath Patra	9937091838 7978602614	indianpower123@gmail.com
		M/s National Casting & Engineering Co., Cuttack	Nayabazar, Cuttack, Odisha- 753004	Mr. Amit Dingal Mr. Salil Kumar Dingal	9937444762 7008811568	salil_switchgear@rediffmail.com nec1986@gmail.com
		M/s Pramoda Engineering Works	S3/12, Phase-2,New industrial Estate,Jagatpur,Cuttack, Pin 754021 odisha.	Mr. Rakhesh malla.	9078071194/9437975180	pramodaengineeringworks@yahoo.in
		M/s Indian Metal Industries, Cuttack	53, Dingal Badi, Cuttack, Gosala Road, PO-Nayabazar, Odisha	Mr. Samir Kumar Dingal Mr. Santanu Dingal	7008696247 9853786663	dingal007@gmail.com

TPCODL		APPROVED MANUFACTURER-DISTRIBUTOR LIST OF TPCODL ( For New Connection work only) Updated Upto 10.01.2024				Valid Till : 31.01.2024
Sr. No	Description of Material/ Equipment	Manufacturer Name	Contact Address	Contact Person	Contact No.	Email ID
13	33 KV Polymer type AB Switch	M/s Sigma Power Industries, Cuttack	Plot no-18, Low Laying Area, Industrial Estate, Khapuria, Madhupatna, Cuttack, 753010, Odisha	Mr. Debankar Biswal	9755550290	sigmapower2020@gmail.com
		M/s Samal Industries, Khurda	Plot No C/10 and 9/1 IID centre Industrial Estate Khurda	Mr. Prakash Samal	9437231336	samalindustries1234@gmail.com
		M/s Indian Power Industries, Cuttack	Jhikiria, 42 Mouza, Cuttack, Odisha- 754112	Mr. Bholanath Patra	9937091838 7978602614	indianpower123@gmail.com
		M/s National Casting & Engineering Co., Cuttack	Nayabazar, Cuttack, Odisha- 753004	Mr. Amit Dingal Mr. Santanu Dingal	9937444762 7008811568	salil_switchgear@rediffmail.com ncec1986@gmail.com
		M/s Pramoda Engineering Works	S3/12, Phase-2, New industrial Estate, Jagatpur, Cuttack, Pin 754021 odisha.	Mr. Rakhesh malla.	9078071194/9437975180	pramodaengineeringworks@yahoo.in
		M/s Indian Metal Industries, Cuttack	53, Dingal Badi, Cuttack, Gosala Road, PO-Nayabazar, Odisha	Mr. Samir Kumar Dingal Mr. Santanu Dingal	7008696247 9853786663	dingal007@gmail.com
14	11 KV Polymer type HG Fuse	M/s Samal Industries, Khurda	Plot No C/10 and 9/1 IID centre Industrial Estate Khurda	Mr. Prakash Samal	9437231336	samalindustries1234@gmail.com
		M/s Indian Power Industries, Cuttack	Jhikiria, 42 Mouza, Cuttack, Odisha- 754112	Mr. Bholanath Patra	9937091838 7978602614	indianpower123@gmail.com
		M/s National Casting & Engineering Co., Cuttack	Nayabazar, Cuttack, Odisha- 753004	Mr. Amit Dingal Mr. Santanu Dingal	9937444762 7008811568	salil_switchgear@rediffmail.com ncec1986@gmail.com
		M/s Indian Metal Industries, Cuttack	53, Dingal Badi, Cuttack, Gosala Road, PO-Nayabazar, Odisha	Mr. Samir Kumar Dingal Mr. Santanu Dingal	7008696247 9853786663	dingal007@gmail.com
		M/s Sigma Power Industries, Cuttack	Plot no-18, Low Laying Area, Industrial Estate, Khapuria, Madhupatna, Cuttack, 753010, Odisha	Mr. Debankar Biswal	9755550290	sigmapower2020@gmail.com
		M/s Pramoda Engineering Works	S3/12, Phase-2, New industrial Estate, Jagatpur, Cuttack, Pin 754021 odisha.	Mr. Rakhesh malla.	9078071194/9437975180	pramodaengineeringworks@yahoo.in
		M/s Kishan Enterprises	115, Mahatma Gandhi Road, Kolkata 700007	Mr. Kishan Jhunjhunwala	7044360716 / 9831163516	kishanenterprises@hotmail.com
15	33 KV Polymer type HG Fuse (200 A)	M/s Indian Metal Industries, Cuttack	53, Dingal Badi, Cuttack, Gosala Road, PO-Nayabazar, Odisha	Mr. Samir Kumar Dingal Mr. Santanu Dingal	7008696247 9853786663	dingal007@gmail.com
16	33 kV Isolator 400/630/800/1250A with & without Earth Switch	M/s Ruma Isolator Company, Howrah	At: 6"Q" Road, Howrah	Md Aslam Parvez	9830221661	rumaisolatorco@gmail.com
		M/s. High Tension Electrical Equipments Pvt. Ltd, Howrah	101, C Road, Belgachia, Dasnagar, Howrah, West Bengal	Mr. Kaushik Das	9831906005	comm1@hightension.in
		M/s Panchkari Kayal & Co, Howrah	Balitikuri, Surkumill, Howrah, West Bengal-711113	Mr. Sandip Hazra	9831429252 8585068611	info.panchkari@gmail.com

TPCODL		APPROVED MANUFACTURER-DISTRIBUTOR LIST OF TPCODL ( For New Connection work only) Updated Upto 10.01.2024				Valid Till : 31.01.2024
Sr. No	Description of Material/ Equipment	Manufacturer Name	Contact Address	Contact Person	Contact No.	Email ID
17	11kV Isolator 400/630/800/1250A with & without Earth Switch	M/s Ruma Isolator Company, Howrah	At: 6"Q" Road, Howrah	Md Aslam Parvez	9830221661	rumaisolatorco@gmail.com
		M/s Panchkari Kayal & Co, Howrah	Baltikuri, Surkumill, Howrah, West Bengal-711113	Mr. Sandip Hazra	9831429252 8585068611	info.panchkari@gmail.com
		M/s Ultima Switchgears Ltd.,Noida	F-6/F-7,UPIIDC,Surajpur Industrial Area,Greater Noida,UP-201336	Mr.Vansh Parmar	9582221901 9953233568	vdp@ultimaswitchgear.com
18	LT XLPE AB Cable	M/s Paramount Communications Ltd,Haryana	Plot No.37,Industrial Estate,Dharuhera,Rewari,Haryana-123106	Mr.Manoj Verma	9958898025	manoj@paramountcables.com
		M/s Akhandalamani Electricals & Constructions, Cuttack	Kuspangi,Cuttack, Odisha	Mr. Prabhat Kumar Rout	9438873224	pravat@aecinfrastucture.com info@aecgroup.in
		M/s MMP Industries Ltd	211 Shrimohini, 345 Kingsway, Nagpur 440001	Mr.Vikrant Sahare	7350017910	vikrants@mmpil.com vvs@mmpil.com
		M/s Laser Power & Infra Pvt Ltd,Howrah	AT/P.O. : NH-6, Polypark, Dhulagore, Howrah-711302	Mr.Aniruddha Banerjee Mr.Sujib Goswami	9674763567 9674761456	lab.poly2016@gmail.com sales@laserpowerinfra.com
		M/s Dynamic Cables Ltd, Jaipur	F-260, Road No. 13, VKIA, Jaipur - 302013	Mr.S. Kadam	9001096020	info@dynamiccables.co.in
		M/s Havells India Pvt. Ltd,Rajasthan	Plot no. A/461-462 & SP-215,204 & 204(A), Matsya Industrial Area, Alwar, Rajasthan	Mr.Rudra Prasad Jena Mr.Barun Mishra	9937051045 8018041545	rudraprasad.jena@havells.com barun.mishra@havells.com
		M/s Lumino Industries Ltd,Howrah	Biprannapara, Jalan Complex,Domjur,Howrah,West Bengal	Mr.Tapas Debnath Mr.Vikash singh	9674755236 9674344474	susant@luminoindustries.com ababaj@luminoindustries.com
		M/s Pobon DPC & Cables Pvt. Ltd, Balasore	Nayakbanda, Bidu, Soro, Balasore,Odisha	Mr. Chandra Sekhara Mohanty	9777277719	pobondpcables@gmail.com
		M/s. Gupta power Infrastructure Ltd,Khurda	F/9, IID Centre,Khurda, Odisha-752054	Mr.Mridul Tyagi Mr.Sandeep Kumar Mr. Debabrata Parida	9821762282 8130388990 9937937659	mridul.tyagi@guptapower.com sandeep@guptapower.com debabrata.parida@guptapower.com
			<b>Authorized Distributors: Ms Dadaji Infratrading PVT LTD.</b>	Mr. Radhakanta Samanta	9938252401 7008069663	Dadaji.infratrading@gmail.com
M/s Polytech Wire and Cables Pvt. Ltd, Rourkela	Gurundia, Lathikata, Rourkela, Sundergarh, Odisha	Mr. Biswajit Pattanaik	8260500168 9776685251	polytechwireandcable@gmail.com		
	Authorized Distributors: Ms Samal Industries	Mr. Prakash chandra Samal	9437231336	samalindustries1234@gmail.com		



TPCODL		APPROVED MANUFACTURER-DISTRIBUTOR LIST OF TPCODL ( For New Connection work only) Updated Upto 10.01.2024				Valid Till : 31.01.2024	
Sr. No	Description of Material/ Equipment	Manufacturer Name	Contact Address	Contact Person	Contact No.	Email ID	
19	1.1KV PVC Insulated Cable and Control Cable	M/s Sterlite Technologies Ltd,Mumbai	9B & 9C, 9th Floor, South Tower, Godrej One, Pirojshanagar, Vikhroli (East), Mumbai - 400079	Mr.Asish Goyal		ashish.goyal@stl.tech	
		M/s Finolex Cables Limited,Bhubaneswar	677, Rudrapur, NH-16, PO: Pahal, Opp Kali Mandir, Bhubaneswar - 752101, Orissa		0674-2602971922 0674-2971188	florissa@finolex.com	
		M/s Universal Cables Limited,Madhya Pradesh	Birla Vikas,Satna,Madhya Pradesh-485005	Mr.A.Bose			kolkata@unistar.co.in sales@unistar.co.in
		M/s Gloster Cables Ltd,Telangana	310/E, NH 44, Kallakal Village, Manoharbad (Mnd), MEDAK, Telangana 502336	Mr. Rajesh Kumar Dutta (Cable Division)		9327239364	rkdutta@glostercable.com marketing@glostercable.com
		M/s Cords Cable Industries Ltd,Rajasthan	A-525,RIICO Industrial Area,Chopanki,Bhiwadi,Alwar, Rajasthan-301019	Mr.Niloy Chakraborty		9831066950	ccil@cordscable.co nc@cordscable.com
		M/s KEI Industries Ltd.,Alwar	SP 919,920,922 RIICO Industrial Area,Phase-3,Bhiwadi,Alwar,Rajasthan 301019	Mr. Chittrak Sardar		99030 27514	bhavana.patil@kei-ind.com chittrak.sardar@kei-ind.com
		M/s Crystal Cable Industries Ltd,Kolkata	32,Ganesh Chandra Avenue,Kolkata,West Bengal-700013				office@crystalcable.in
		M/s. Gupta power Infrastructure Ltd,Khurda	F/9, IID Centre,Khurda, Odisha-752054	Mr.Mridul Tyagi Mr.Sandeep Kumar Mr. Debabrata Parida		9821762282 8130388990 9937937659	mridul.tyagi@guptapower.com sandeep@guptapower.com debabrata.parida@guptapower.com
				<b>Authorized Distributors:</b> <b>Ms Dadaji Infratrading PVT LTD.</b> ( 1.1KV PVC Insulated Cable )	Mr. Radhakanta Samanta		9938252401 7008069663
		M/s Havells India Pvt. Ltd,Rajasthan	Plot no. A/461-462 & SP-215,204 & 204(A), Matsya Industrial Area, Alwar, Rajasthan	Mr.Rudra Prasad Jena Mr.Barun Mishra		9937051045 8018041545	nudraprasad.jena@havells.com barun.mishra@havells.com
		M/s KEC International Ltd.,Mysore	Mysore,Karnataka	Mr.Satish Tomar		8212402401	tomarsk@kecprg.com powercables@kecprg.com
		M/s Daksha Cable Industries Pvt Ltd(DCD),Mumbai	A-143,Govt Industrial Estate,Charkop Kandivali(West),Mumbai				dakshacables@hotmail.com
		M/s V-Guard Industries Ltd.,Bhubaneswar	42/962, Vennala High school Road, Kochi				mail@vguard.in
		M/s GEMSCAB Industries Ltd,Rajasthan	Plot No.SP-1192 L&K,Phase-4,RIICO Industrial Area,Bhiwadi,Alwar,Rajasthan				gemscab@vsnl.com sureshchandra@gemscab.com
		Mohta Electro system,Gujurat	M/s Mohta Electric & Engineering Co.A-5, 3rd Floor, Safal Profitiare,Corporate Road, Prahlad Nagar,Ahmedabad - 380 051,Gujarat			794032 2212 794032 2213	info@mohtaelectric.com
		M/s Torrent Cables Ltd, Gujrat	PELICAN Building, 6th Floor,GCCI Compound Ashram Road,Ahmedabad, Gujarat - 380009	Mr. S.C. Palekar (VP-Operation)		7930001067	sushampalekar@torrentcables.com
		M/s Thermo Cables Ltd, Hyderabad	28, Nagarjuna Hills,Punjugutta,Hyderabad-500 082			9339336204	kolkata@thermocables.com info@thermocables.com
		M/s Paramount Communications Ltd,Haryana	Plot No.37,Industrial Estate,Dharuhera,Rewari,Haryana-123106	Mr.Manoj verma		9958898025	manoj@paramountcables.com
		M/s Radiant Cables,New Delhi	RADIANT INFO SOLUTIONS PVT. LTD. Y-53, Ground Floor,Okhla Industrial Area, Phase2,New Delhi-110020				info@radiant.in
		M/s Ravin Cables Ltd,Mayurbhanj	Hamilton Gardens Baripada, Dist. Mayurbhanj Orissa - 757001	Mr.Santosh George			santosh.george@ravingroup.com ho@ravincables.com
M/s Laser Power & Infra Pvt Ltd,Howrah	AT/P.O. : NH-6, Polypark, Dhulagore, Howrah-711302	Mr. Aniruddha Banerjee Mr.Sujib Goswami		9674763567 9674761456	lab.poly2016@gmail.com sales@laserpowerinfra.com		
M/s Nicco Corporation Limited,Mayurbhanj	Hamilton Gardens,Baripada,Mayurbhanj,Odisha-757001	Mr.V R Moza		06792-252454 06792-252434	niccomkt@niccocable.com vrmoza@niccocable.com		

TPCODL		APPROVED MANUFACTURER-DISTRIBUTOR LIST OF TPCODL ( For New Connection work only) Updated Upto 10.01.2024				Valid Till : 31.01.2024
Sr. No	Description of Material/ Equipment	Manufacturer Name	Contact Address	Contact Person	Contact No.	Email ID
20	PVC Wire	M/s Havells India Pvt. Ltd,Rajasthan	Plot no. A/461-462 & SP-215,204 & 204(A), Matsya Industrial Area, Alwar, Rajasthan	Mr.Rudra Prasad Jena Mr.Barun Mishra	9937051045 8018041545	rudraprasad.jena@havells.com barun.mishra@havells.com
		M/s. Gupta power Infrastructure Ltd, Khurda	F/9, IID Centre,Khurda, Odisha-752054	Mr.Mridul Tyagi Mr.Sandeep Kumar Mr. Debabrata Parida	9821762282 8130388990 9937937659	mridul.tyagi@guptapower.com sandeep@guptapower.com debabrata.parida@guptapower.com
		M/s Polycab India Ltd,Gujarat	Unit 4, Plot No.105, Halol Vadodara Road,Nurpura, Halol, Panchmahal, Gujarat	Mr.Lalit	9437014212	enquiry@polycab.com info@polycab.com
		M/s Anchor Electricals Pvt Ltd	Steel House, B wing, Plot No. 24, Mahal Industrial Estate, Mahakali Caves Road, Near Paper Box, Andheri, Mumbai-400093, Maharashtra, India	Mr. Kavish Kotian	07045785821	
		M/s Finolex Cables Ltd, Bhubaneswar	677, Rudrapur, NH-16, PO: Pahal, Opp Kali Mandir, Bhubaneswar - 752101, Orissa		0674-2971922, 0674-2971188	felorissa@finolex.com
		L&T		Mr.Atul Singh		atulsingh@Intecc.com
21	AAAC Conductor	M/s APAR Industries Ltd, Gujarat	Plot No.153,157-163,2827,Survey 189/P1,Umbergaon,Valsad,Gujarat-396171	Mr. S K Suman	9967719156 8291664446	shyam.suman@apar.com m.kanakarajan@apar.com
		M/s. Lumino Industries Ltd,Howrah	Biprannapara, Jalan Complex,Domjur,Howrah,West Bengal	Mr.Tapas Debnath Mr.Vikash Singh	9674755236 9674344474	susant@luminindustries.com abajaj@luminindustries.com
		M/s Akhandalamani Electricals & Constructions, Cuttack	Kuspangi,Cuttack, Odisha	Mr. Prabhat Kumar Rout	9438873224	pravat@acinfrastructure.com info@accgroup.in
		M/s MMP Industries Ltd	211 Shrimohini, 345 Kingsway, Nagpur 440001	Mr. Vikrant Sahare	7350017910	wikrants@mmpil.com vvs@mmpil.com
		M/s Pobon DPC & Cables Pvt. Ltd, Balasore(AAAC)	Nayakbanda, Bidu, Soro, Balasore,Odisha	Mr. Chandra Sekhara Mohanty	9777277719	pobondpcables@gmail.com
		M/s Mahavir Transmission Limited, Uttarakhand	A-9,B-4,A-11-13 S, Industrial Estate, Vikasnagar, Dehradun, Uttarakhand 248198	Mr. Akhil Jain	8447813337 9871002668	akhil.jain@mahavirtransmission.com
		M/s Polytech Wire and Cables Pvt. Ltd, Rourkela	Gurundia, Lathikata, Rourkela, Sundergarh, Odisha	Mr. Biswajit Pattanaik	8260500168 9776685251	polytechwireandcable@gmail.com
		Authorized Distributors: Ms Samal Industries	Mr. Prakash chandra Samal	9437231336	samalindustries1234@gmail.com	
22	HT XLPE Insulated Covered AAAC Conductor (11kV)	M/s APAR Industries Ltd, Gujarat	Plot No.153,157-163,2827,Survey 189/P1,Umbergaon,Valsad,Gujarat-396171	Mr. S K Suman	9967719156 8291664446	shyam.suman@apar.com m.kanakarajan@apar.com
		Authorized Distributors: 1. M/s Samal Industries, Khurda Plot No C/10 and 9/1 IID centre Industrial Estate Khurda	Mr. Prakash Samal	9437231336	samalindustries1234@gmail.com	
		M/s KEI Industries Ltd.,Alwar	SP 919,920,922 RIICO Industrial Area,Phase-3,Bhiwadi,Alwar,Rajasthan-301019	Mr. Chitrak Sardar	99030 27514	bhavana.patil@kei-ind.com chitrak.sardar@kei-ind.com
		M/s. Gupta power Infrastructure Ltd, Khurda	F/9, IID Centre,Khurda, Odisha-752054	Mr.Mridul Tyagi Mr. Sandeep Kumar Mr. Debabrata Parida	9821762282 8130388990 9937937659	mridul.tyagi@guptapower.com sandeep@guptapower.com debabrata.parida@guptapower.com
		Authorized Distributors: Ms Dadaji Infratrading PVT LTD.	Mr. Radhakanta Samanta	9938252401 7008069663	Dadaji.infratrading@gmail.com	

TPCODL		APPROVED MANUFACTURER-DISTRIBUTOR LIST OF TPCODL ( For New Connection work only) Updated Upto 10.01.2024				Valid Till : 31.01.2024
Sr. No	Description of Material/ Equipment	Manufacturer Name	Contact Address	Contact Person	Contact No.	Email ID
23	HT XLPE Cable ( 11KV & 33 KV)	M/s Gupta power Infrastructure Ltd,Uttarakhand	132,Nandanagar Industrial Estate,Phase-2,Mahuakherganj,Kashipur,Uttarakhand-244713	Mr.Mridul Tyagi Mr.Sandeep Kumar Mr. Debabrata Parida	9821762282 8130388990 9937937659	mridul.tyagi@guptapower.com sandeep@guptapower.com debabrata.parida@guptapower.com
			Authorized Distributors: Ms Dadaji Infratrading PVT LTD.	Mr. Radhakanta Samanta	9938252401 7008069663	Dadaji.infratrading@gmail.com
		M/s KEI Industries Ltd.,Alwar	SP 919,920,922 RIICO Industrial Area,Phase-3,Bhiwadi,Alwar,Rajasthan 301019	Mr. Chitrak Sardar	99030 27514	bhavana.patil@kei-ind.com chitrak.sardar@kei-ind.com
		M/s GEMSCAB Industries Ltd,Rajasthan	Plot No.SP-1192 L&K,Phase-4,RIICO Industrial Area,Bhiwadi,Alwar,Rajasthan		9212560974	gemscab@vsnl.com sureshchandra@gemscab.com anpathak@gemscab.com
		M/s Havells India Pvt. Ltd.,Alwar(only for 11kV)	Plot no. A/461-462 & SP-215,204 & 204(A), Matsya Industrial Area, Alwar, Rajasthan	Mr.Rudra Prasad Jena Mr.Barun Mishra	9937051045 8018041545	rudraprasad.jena@havells.com barun.mishra@havells.com
		M/s Dynamic Cables Ltd, Jaipur	F-260, Road No. 13, VKIA, Jaipur - 302013	Mr.S. Kadam	9001096020 9339830586	info@dynamiccables.co.in tenderingdcl@dynamiccables.co.in
24	HT & LT Cable termination & Jointing kit (Except Touchproof kit)	M/s 3M Electro & Communication India Pvt Ltd,Pune	145,Mumbai-Pune Road,Pimpri,Pune,Maharashtra	Mr.Sujit Kumar Nayak Mr.Abhijit Bhagwat	98306 62725 9850667259	arbhagwat@mmm.com sknayak@mmm.com
			M/s Raychem RPG Pvt Ltd.,Gujurat	Kanjari,Jyoti Compound,Nr Halol GIDC,Panchamahaj,Gujarat	Mr.Rahul Biswas Mr. Saurav Maiti	9771427299 8372801987
		M/s Nexans (PCA Technologies Pvt Ltd.)	25,shah industries Estate, Kotambi, Vadodara, Gujrat , India 391510	Mr. Soman Maitra	9830559759	suman@thepcotech.com
		M/s Behr Bircher Cellpack BBC India Pvt. Ltd., Haryana	Plot No. 149, EHTP, Phase-5, Sector-56, HSIIDC Kundli, Sonipat, Haryana-131028	Mr. Soman Maitra	9830559759	suman.maitra@cellpack.com
25	Covered Conductor Accessories	M/s Raychem RPG Pvt Ltd.,Gujurat	Kanjari,Jyoti Compound,Nr Halol GIDC,Panchamahaj,Gujarat	Mr.Rahul Biswas Mr.Mehul Patel	9771427299 9724304622	rahul_biswas@raychemrpg.com Sourav_Maiti@raychemrpg.com
		M/s ENSTO India Pvt. Ltd, Haryana	Plot No. 241, Sector-6, IMT Manesar Gurugram - 122050, Haryana, India	Mr. Amit Biswas	9163503551	amit.biswas@ensto.com india@ensto.com
26	HDPE Pipes	M/s Aadi Polyextrusion & Moulding Pvt. Ltd,Cuttack	B 44 & 45, New Industrial Estate, Jagatpur, Cuttack, Odisha	Mr. S Mohanty	9861096647 9439755400	aadi.polyfit@gmail.com orissaplastpipes@rediffmail.com
		M/s Lingaraj Pipes Pvt. Ltd., Khurda	IDCO, Plot No. A/12, Sarua Industrial Estate, Sarua, Khurda, Odisha	Mr. Prashant Ku. Mishra	9040088846 8763211377	support@lingarajpipes.com
		M/s Hari Udyog Pvt Ltd, Balasore	Khanagar, Kuruda, Balasore, Odisha	Mr. H.K. Mohanty Mr. Tarun Ray	7894435270 9437963776	hariplaast@hariplaast.com ray.hupl@hariplaast.com hkmohanty@hariplaast.com
		M/s Valentina Pipes Pvt. Ltd, Bhubaneswar	A/22-23-24, Industrial Estate, Rasulgarh, Bhubaneswar-751010, Odisha	Mr. Nikunj Chhotray Mr. Praddep Pradhan	9437025882 8249322439	lion_nikunj@yahoo.co.in valentinapipespvtltd18@gmail.com
		M/s Metroplast Industries,Kuruda,Balasore	Kuruda, Near Kuruda Fly Over, NH-16, Balasore-756056, Odisha	Mr. S.K.Tripathy	9338833733 8249386985	metro_plast@yahoo.com sktripathy.279@gmail.com
		Ms Balaji Techproducts Pvt. Ltd	Plot no 9 (p),10(p) and 11(p) Kurki industrial area , Dist Puri	Mr. Sridhar kumar sethy	9778917213	balajitechproducts@gmail.com
		Ms Flexiflow Polymers LLP	Khasra No.143, Plot No.858-859, Kanjhawala Industrial Area, North West Delhi, Delhi-110081	Mr. Sukdeb Bansal	8076895170	quality@flexiflowpipe.com
		Ms Oriplast LTD.	Alupur, O.T Road, Balasore.	Mr. Alok Dalai	7735732024	alokdalai@oriplast.in
M/s Magnum Fibres Pvt. Ltd., Bhubaneswar	Plot No-132-A,Sector-A,Zone-A, Mancheswar Indl. Estate, Bhubaneswar - 751010 (ODISHA)	Mr. Biraja Prasad Acharya Mr. A.P. Malla	9040011139 9040011130	birajaacharya@magnum-india.com malla@magnum-india.com		

TPCODL		APPROVED MANUFACTURER-DISTRIBUTOR LIST OF TPCODL ( For New Connection work only) Updated Upto 10.01.2024				Valid Till : 31.01.2024
Sr. No	Description of Material/ Equipment	Manufacturer Name	Contact Address	Contact Person	Contact No.	Email ID
27	MCB	L&T		Mr.Atul singh		atulsingh@Intecc.com
		M/s ABB India Ltd,Bhubaneswar	1st Floor,City centre,A-5/1.Sachivalaya Marg,Unit-9,Bhubaneswar-751022			contact.center@in.abb.com
		M/s SIEMENS Ltd,Kolkata	43,Shanti Pally,EM ByPass,Connector,Rashbehari Avenue,Kolkata			adwaita.mukherjee@siemens.com anit.mitra@siemens.com
		M/s Havells India Pvt. Ltd,Uttarakhand	Plot no. 6, Site-4, Sahibabad Industrial Area, Sahibabad, Ghaziabad, UttarPradesh-201010	Mr.Siddhartha Das	9937203309	siddhartha.das@havells.com
		M/s Standard Electricals Ltd,Noida	Global Headquarters , QRG Towers,2D, Sec- 126, Expressway, Noida - 201304 U.P			standard.ho@havells.com
		M/s Schneider Electric Infrastructure Ltd,Bhubaneswar	14,Forest Park,Bhubaneswar-751009	Mr.Girija Patnaik		girija.patnaik@schneiderelectric.com
		Legrand, Kolkata	Bhakta Towers, 2nd & 3rd Floor, Plot No. KB 22, Salt Lake, Sector - 3, KOLKATA - 700 091			
		M/s Crompton Greaves India Ltd,Mumbai	Equinox Business Park, 1st Floor,Tower-3,LBS Marg,Kurla(W),Mumbai-400070	Mr.Thomas Geevarghese Mr.Subhasis	9831038155	nsm@crompton.co.in thomas.geevarghese@cglobal.com
		MERLIN GERIN				
M/s. C & S India Pvt Ltd,Uttarakhand	Plot no.10,Sector-11,IIE,SIDCUL,Ranipur,Haridwar, Uttarakhand-249403	Mr.Gaurav Sharma	9650564714	mvservice@c-sec.co.in		
28	LT ACB/MCCB	L&T		Mr.Atul Singh		atulsingh@Intecc.com
		M/s SIEMENS Ltd,Kolkata	43,Shanti Pally,EM By Pass,Connector,Rashbehari Avenue,Kolkata-700042			adwaita.mukherjee@siemens.com anit.mitra@siemens.com
		MERLIN GERIN				
		M/s GE Power Controls India Pvt Ltd, Bangalore	42/1 & 45/14,Electronic City Phase-2,Bangalore-560100			08041113000
		M/s ABB India Ltd,Bhubaneswar	1st Floor,City centre,A-5/1.Sachivalaya Marg,Unit-9,Bhubaneswar-751022			contact.center@in.abb.com
		M/s Crompton Greaves India Ltd,Mumbai	Equinox Business Park, 1st Floor,Tower-3,LBS Marg,Kurla(W),Mumbai-400070	Mr.Thomas Geevarghese Mr.Subhasis	9831038155	nsm@crompton.co.in thomas.geevarghese@cglobal.com
		M/s Havells India Pvt. Ltd,Uttar Pradesh	Plot no. 6, Site-4, Sahibabad Industrial Area, Sahibabad, Ghaziabad, UttarPradesh-201010	Mr.Siddhartha Das	9937203309	siddhartha.das@havells.com
		M/s. C & S India Pvt Ltd,Uttarakhand	Plot no. 10,Sector-11,IIE,SIDCUL,Ranipur,Haridwar, Uttarakhand-249403	Mr. Gaurav Sharma	9650564714	mvservice@c-sec.co.in
		M/s BCH Electric Ltd, Haryana	20/4, Mathura Road, Faridabad – 121 006 Haryana			marketing@bchindia.com
		M/s ERA Electricals Pvt Ltd,Noida	Plot No.B-200, Phase-II, Noida, Uttar Pradesh, 201305	Mr. Mukesh Gupta Mr.Sachin gupta		
M/s Schneider Electric Infrastructure Ltd,Bhubaneswar	14,Forest Park,Bhubaneswar-751009	Mr. Girija Patnaik		girija.patnaik@schneiderelectric.com		

TPCODL		APPROVED MANUFACTURER-DISTRIBUTOR LIST OF TPCODL ( For New Connection work only) Updated Upto 10.01.2024				Valid Till : 31.01.2024
Sr. No	Description of Material/ Equipment	Manufacturer Name	Contact Address	Contact Person	Contact No.	Email ID
29	Switches	M/s Anchor Electricals Pvt Ltd,Mumbai	Steel House, B wing, Plot No. 24, Mahal Industrial Estate, Mahakali Caves Road, Near Paper Box, Andheri, Mumbai-400093, Maharashtra, India	Mr. Kavish Kotian	07045785821	
		M/s Schneider Electric Infrastructure Ltd,Bhubaneswar	14,Forest Park,Bhubaneswar-751009	Mr. Girija Patnaik		girija_patnaik@schneiderelectric.com
		INDOASIAN , Maharashtra	Indo Asian Building Pvt. Ltd.,Eternity Mall Teen Hath Naka, Lal Bahadur Shastri Rd, Thane West, Thane, Maharashtra 400604			
		M/s Havells India Pvt. Ltd,Ghaziabad	Plot no. 6, Site-4, Sahibabad Industrial Area, Sahibabad, Ghaziabad, UttarPradesh-201010	Mr.Siddhartha Das	9937203309	siddhartha.das@havells.com
		M/s CONA Industries Pvt Ltd, Mumbai	302 Brahans Business Park, Off Mahakali Caves Rd, Andheri East, Mumbai, Maharashtra 400093			
		M/s ABB India Ltd, Bhubaneswar	1st Floor,City centre,A-5/1.Sachivalaya Marg,Unit-9,Bhubaneswar-751022			contact.center@in.abb.com
30	Cable Tie	M/s Mangal Enterprises Ltd, New Delhi	1743/46, 1st Floor,Electrical Market,Bhagirath Palace,Chandini Chowk,Delhi-110006	Mr.Bhuwan Pandey	8800702333	mangalenterprises2011@gmail.com
		M/s Novoflex Marketing Pvt Ltd, West Bengal	Raikva-5th Floor,Unit-6,3A,Ram Mohan Mullick Garden Lane,Kolkata,West bengal-700010	Mr.Vineet Kumar Banka	9903163634	sales@novoflex.in
		M/s Ripkons Tradewings, New Delhi	N1-79,Sector-5,DSHDC,Biswana Industrial Area,New Delhi-110039	Mr.Nilesh Hirani	9810764004	hiranineesh@yahoo.co.in
31	PSC Pole (300 Kg/9 mtr)	M/s Konark Construction & Engineers Ltd,Cuttack	On NH-16,Telengapentha, Cuttack,Odisha	Mr.Priya Ranjan Shial Mr.Giridharilal Halan	9668025336 9437012866	kcel05@hotmail.com
		M/s SR Cementech, Cuttack	Nischint,Benchua,Govindpur Chhak,Tangi,Cuttack,Odisha	Mr.Tarun Agarwal	9583212121	em.rahul@gmail.com
		M/s Divine Concrete Pvt. Ltd, Jajpur	Mandia,Haridaspur,Chandikhola,Jajpur,Odisha	Mr.S P Sahoo	9437042868	divineconcreteproducts@gmail.com
		M/s BabaAkhandalamani,Bhadrak	Randia,Bhadrak,Odisha	Mr.Chinmay T. Mohapatra	9040045476	babaconcrete17@gmail.com
		M/s Metro Poles,Balasure	Sahada,Sarhaon,Balasure,Odisha	Mr.Rajiv Shah	8249827644	metro_poles@yahoo.com
		M/s Neelachal Enterprises, Chhanpur, Balasure	Bampada, Chhanpur, Balasure, Odisha	Mr. Harish Patel	9437013147	neelcon@gmail.com
		M/s KMR Udyog, Balasure	At- Gadiamal, Po- Bahal, Via- Sergarh, Dist- Balasure, Odisha, Pin-756060	Mr. Mahesh Kumar Modi	9556196809	kmrudyg@gmail.com
		M/s Balaji PSC Poles Industries,Khurda	353/46,Jaydev Vihar,Near Vishnu Priya Appartment, Bhubaneswar, Khurda, Odisha	Mr. S P Mohapatra	9937528888 9437078787	sauriprasad@yahoo.com
		M/s Baba Loknath Pvt Ltd,Khurda	Kuhudi,Khurda	Mr.Bijay Pradhan Mr.Ravi Sharma	9937397199 9861058123	loknathdev@gmail.com
		M/s Laxmi Industries, Khurda	C-35 & C-36, IID Centre, Khurda Industrial Estate,Khurda, Odisha-752055	Mr. Bipin Trivedi	9934316366	laxmi.enterprises@gmail.com
		M/s Omm Concrete Products, Bhubaneswar	Kujimahal, Chandaka, Bhubaneswar, Khurda, Odisha	Mr. K.C.Padhi	9438877282	ommconcretes@yahoo.com
		M/s Gayatri Industry,Ganjam	Kalabada, Chikiti, Ganjam, Odisha	Mrs.Subhadra Sahu	9439331387	subhadra.sahu@gmail.com
		M/s Lackeir Stilit Pvt Ltd ,Ganjam	Palurgarh,Rambha,Huma, Ganjam, Odisha	Mr.K Dileswar Rao	9437434611 9337227923	kdr.lackeir@gmail.com
		M/s Sai Saran Concrete, Talcher	Remuan,Hatatota,Talcher,Angul,Odisha	Mr.Shivram Sahoo	7381040188 7381040189	saisaranconcrete48@gmail.com
		M/s Gautam Cements Works Ltd,Jharsuguda	Hirma,Badmal,Jharsuguda,Odisha	Mr.Abhijeet Surana Mr.Nirabh Mehta	9600221111 9165053638	orissapole@gmail.com
		M/s Meco, West Bengal	Bolpur, Birbhum, West Bengal	Munshi Asad Ali	9434762432	asadsppl@gmail.com

TPCODL		APPROVED MANUFACTURER-DISTRIBUTOR LIST OF TPCODL ( For New Connection work only) Updated Upto 10.01.2024				Valid Till : 31.01.2024
Sr. No	Description of Material/ Equipment	Manufacturer Name	Contact Address	Contact Person	Contact No.	Email ID
32	WPB / RSJ Pole (11 & 13 mtr)	M/s Supreme & Co Pvt Ltd & M/s Utkal Galvanizers Ltd,Cuttack	Kapursingh,Oranda,Cuttack, Odisha	Mr. Arun K Das	9938410739 8249608042	ho@utkaldt.in utkalho@gmail.com
		M/s Reliable Sponge Pvt Ltd, Sundergarh	Unit-3,Sagjore,Balanda,Sundergarh,Odisha	Mr. Pranab Mohanty	9437497402	tlr@reliableispat.com
			<b>Authorized Distributors:</b> <b>1. M/s Bright Steel,</b> Cuttack Road, Bhubaneswar, Odisha <b>2. M/s S R Cementech, Tangi, Cuttack</b> <b>3. M/s Konark Steel &amp; Pipes,</b> A/16, Industrial Estate, Madhupatana, Cuttack <b>4. M/s Steel Industries of Orissa,</b> 291, Bhomikhal, Cuttack-Puri Road, Bhubaneswar	1. Mr. Virendra Kheria 2. Mr. Tarun Agarwal 3. Mr. Sudhakar Sahoo 4. Mr. Deepak Poddar	1. 9040000500 9078956299 2. 9583212121 3. 9776655862 4. 9437075001	1. brightsteel_bbsr@rediffmail.com sales@brightsteel.co.in 2. em.raahul@gmail.com 3. kspbbsr.1927@gmail.com 4. deepakbbsr@gmail.com
		M/s New Laxmi Steel & Power Pvt Ltd, Khurda	Plot No.: A/22-25, Sarua Industrial Estate, Khordha, Odisha	Mr. Srikant Samantray Er. Bipin Kumar Buruwal	9437055908 6289715340	newlaxmisteel@gmail.com newlaxmisteelfactory@gmail.com
			<b>Authorized Distributors:</b> <b>1. M/s Samal Industries, Khurda</b> Plot No C/10 and 9/1 IID centre Industrial Estate Khurda <b>2. M/s Sai Saran Concrete, Talcher</b> Remuan,Hatatota,Talcher,Angul,Odisha	1. Mr. Prakash Samal 2. Mr. Shivram Sahoo	1. 9437231336 2. 7381040188      7381040189	1. samalindustries1234@gmail.com 2. saisaranconcrete48@gmail.com
		M/s Swastika Steel & Allied Products Pvt. Ltd., Howrah	AT: 8/1, Nutan Para Road, Liliuah, Howrah, West Bengal- 711204	Mr. Ravinder Sharma	9339775648	rks@swastikasteel.com
M/s K L Steels Pvt Ltd,Uttar Pradesh	G.T.Bulandshahar Road,Near Lal Kuan,Chippyana,Gautam Budh Nagar,Uttar Pradesh	Mr.Nageshwar Prasad Mr.Jagdeesh Sharma	9810235789 7291992004	mrc@klsons.in sales.rajesthan@klsons.in		
M/s Vijay Transmission Pvt Ltd, Raipur	Kanhera,Dharsiva,Ura Acholi road,Raipur, Chhatisgarh	Mr. Abhishek Dwivedi Mr.A Kodape	9753872335 9425503518	abhishekdv@vijaytransmission.com koushals@vijaytransmission.com		
33	Rebar Lacing Pole/H-Pole(14 mtr)	M/s Reliable Sponge Pvt Ltd, Sundergarh	Unit-3,Sagjore,Balanda,Sundergarh,Odisha	Mr. Pranab Mohanty	9437497402	tlr@reliableispat.com
34	SMC LT Distribution Box	M/s Sanskriti Composites Pvt Ltd, Hooghly	Mollerberh,Bhadua NH-2 Delhi Road,Hooghly,West Bengal	Mr.Aayush Jhunjunwala	9831158358	aayush@sanskriticomposites.com
		M/s Plasto Tech Industries Pvt Ltd, Pune	Plot No.3413,Talegaon Dhamdhare Talshirur, Pune,Maharashtra-412208	Mr.Jalinder P Bhujbal	8380035350 8380035352	plastotech@yahoo.com
		M/s Neelu Packing Industries Pvt Ltd, Uttar Pradesh	B-16,Sector-83,Noida,Uttar Pradesh	Mr.Manas Samal	8800538206	info@neelupacking.net neelupacking@gmail.com
		M/s Sintex Industries, Ahmedabad	119,Kalasar,Shopping Hub,1st floor,Opposite Sai Baba Temple,Sattadhar,Ahmedabad,Gujarat	Mr.Jigar	9909980572	jigar.brahmbhatt@sintex.co.in
35	M.S/GLT Distribution Box	M/s Bose Engineering (India) Pvt Ltd, Kolkata	K-14 Behela Industrial Estate,620 D.H Road,Kolkata,West Bengal-700034	Mr.Anindaya K Bose	9830063810	anind_bose@yahoo.co.in
		M/s S R Automation Pvt Ltd, Kolkata	Arapanch,Sonarpur,Kolkata,West Bengal-700150	Mr.B Sarkar	9831214861 9903050297	s_r_automation61@yahoo.com sr_automation@rediffmail.com factory@srautomationkolkata.com
		M/s J D Electrical Products Pvt Ltd,Kolkata	30,Bakrahat Road,Kolkata,Near Hospital Moore,West Bengal-700104	Ms. Rinka Ghosh Mr.Soumya Ghosh	8017024048 9804263626	rinka_ghosh@jde.co.in soumya_ghosh@jde.co.in
		M/s Arun Enterprises, Sahibabad, New delhi	B-48,site IV,Sahibabad-201010 , Dist -Ghaziabad(UP)	Mr. Nayan Raj / Narendra singh	7042896191 7042896177	mktg2arunenterprises@gmail.com // td@arunenterprises.in // enquiry@arunenterprises.in

TPCODL		APPROVED MANUFACTURER-DISTRIBUTOR LIST OF TPCODL ( For New Connection work only) Updated Upto 10.01.2024				Valid Till : 31.01.2024	
Sr. No	Description of Material/ Equipment	Manufacturer Name	Contact Address	Contact Person	Contact No.	Email ID	
36	All GI Channel, Angle , Flat,GI Pipe, V Cross Arm & Clamp, Pole Clamp	M/s Reliable Sponge Pvt Ltd, Sundergarh	Unit-3,Sagjore,Balanda,Sundergarh,Odisha	Mr. Pranab Mohanty	9437497402	tlt@reliableispat.com	
			<b>Authorized Distributors:</b> 1. M/s Bright Steel, Cuttack Road, Bhubaneswar, Odisha 2. M/s S R Cementech, Tangi, Cuttack 3. M/s Konark Steel & Pipes, A/16, Industrial Estate, Madhupatana, Cuttack 4. M/s Steel Industries of Orissa, 291, Bhomikhal, Cuttack-Puri Road, Bhubaneswar	1. Mr. Virendra Kheria 2. Mr. Tarun Agarwal 3. Mr. Sudhakar Sahoo 4. Mr. Deepak Poddar	1. 9040000500 9078956299 2. 9583212121 3. 9776655862 4. 9437075001	1. brightsteel_bbsr@rediffmail.com sales@brightsteel.co.in 2. em.rahul@gmail.com 3. kspbbsr.1927@gmail.com 4. deepakbbsr@gmail.com	
		M/s New Laxmi Steel & Power Pvt Ltd, Khurda	Plot No.: A/22-25, Sarua Industrial Estate, Khordha, Odisha	Mr. Srikant Samantray Er. Bipin Kumar Burnwal	9437055908 6289715340		newlaxmisteel@gmail.com newlaxmisteelfactory@gmail.com
			<b>Authorized Distributors:</b> 1. M/s Samal Industries, Khurda Plot No C/10 and 9/1 IID centre Industrial Estate Khurda 2. M/s Sai Saran Concrete, Talcher Remuan,Hatatota,Talcher,Angul,Odisha	1. Mr. Prakash Samal 2. Mr. Shivram Sahoo	1. 9437231336 2. 7381040188      7381040189	1. samalindustries1234@gmail.com 2. saisanranconcrete48@gmail.com	
		M/s J B Construction & Services, Kendrapara *(33kV & 11kV V-Cross Arm)	Narasinghpur,Gahaga Narasinghpur,Kendrapara,Odisha	Mr. Pratap Ranjan Panda	7978034822	pratap.jbcs@gmail.com	
		M/s. High Tension Electrical Equipments Pvt. Ltd,Howrah	101, C Road, Belgachia, Dasnagar,Howrah, West Bengal	Mr. Kaushik Das	9831906005	comm1@hightension.in	
		M/s KSE Electricals,Howrah	3rd Main road,NH-6,Begri,Howrah,West Bengal	Mr. Ashis. K Palit	9830547600	mkte@kse.in	
		M/s Industrial Forging Industries Pvt Ltd,Howrah	Jalan Complex, Gate No.1, Biparnapara, Howrah,West Bengal	Mr. Amit Daga Mr. Arindam Dutta	9831241956 7685835234	amit@dagagroup.com mpandit@dagagroup.com	
		M/s Vijay Transmission Pvt Ltd, Raipur	Kanhera,Dharsiva,Ura Acholi road,Raipur, Chhatisgarh	Mr. Abhishek Dwivedi Mr. A Kodape	9753872335 9425503518	abhishekd@vijaytransmission.com koushals@vijaytransmission.com	
		M/s Rahul Electricals,Howrah	P-85/22,Benaras Road,Belgachia,Howrah, West Bengal	Mr. Sachin Giri	7003284140 9836539130	rahulelectricals40@gmail.com	
M/s Jainco Transmission Ltd, Howrah	Jalan Complex, Gate No. 1, Lane No. 7, NH-6, Howrah, West Bengal	Mr. Pratul Ghosh	9831607956	engg@jainco.net			
	<b>Authorized Distributors:</b> 1. M/s Samal Industries, Khurda Plot No C/10 and 9/1 IID centre Industrial Estate Khurda	1. Mr. Prakash Samal	1. 9437231336	1. samalindustries1234@gmail.com			
M/s Pramoda Engineering Works	S3/12, Phase-2,New industrial Estate,Jagatpur,Cuttack, Pin 754021 odisha.	Mr. Rakesh malla.	9078071194/9437975180	pramodaengineeringworks@yahoo.in			
M/s Rajesh Electricals, Howrah	Salap 1, Kantalia Industrial Complex, Howrah Amta Road, Nibra, Howrah, West Bengal	Mr. Rajesh Punatar	9830169125	rajeshlectricalskol@gmail.com			
37	Hardware fittings,GI Pin,GI HT & LT Stay Set	M/s Jainco Transmission Ltd, Howrah	Jalan Complex, Gate No. 1, Lane No. 7, NH-6, Howrah, West Bengal	Mr. Pratul Ghosh	9831607956	engg@jainco.net	
			<b>Authorized Distributors:</b> 1. M/s Samal Industries, Khurda Plot No C/10 and 9/1 IID centre Industrial Estate Khurda	1. Mr. Prakash Samal	1. 9437231336	1. samalindustries1234@gmail.com	
		M/s Industrial Forging Industries Pvt Ltd,Howrah	Jalan Complex, Gate No.1, Biparnapara, Howrah,West Bengal	Mr. Amit Daga Mr. Arindam Dutta	9831241956 7685835234	amit@dagagroup.com mpandit@dagagroup.com	
		M/s Pramoda Engineering Works	S3/12, Phase-2,New industrial Estate,Jagatpur,Cuttack, Pin 754021 odisha.	Mr. Rakesh malla.	9078071194/9437975180	pramodaengineeringworks@yahoo.in	

TPCODL		APPROVED MANUFACTURER-DISTRIBUTOR LIST OF TPCODL ( For New Connection work only) Updated Upto 10.01.2024				Valid Till : 31.01.2024
Sr. No	Description of Material/ Equipment	Manufacturer Name	Contact Address	Contact Person	Contact No.	Email ID
38	GI Stay Wire ,GI Barbed Wire, GI Earthing Coil,GI Wire	M/s Jainco Transmission Ltd, Howrah	Jalan Complex, Gate No. 1, Lane No. 7, NH-6, Howrah, West Bengal	Mr.Pratul Ghosh	9831607956	engg@jainco.net
			<b>Authorized Distributors:</b> 1. M/s Samal Industries, Khurda Plot No C/10 and 9/1 IID centre Industrial Estate Khurda	1. Mr. Prakash Samal	1. 9437231336	1. samalindustries1234@gmail.com
		M/s Industrial Forging Industries Pvt Ltd,Howrah	Jalan Complex, Gate No.1, Biparnapara, Howrah,West Bengal	Mr.Amit Daga Mr.Arindam Dutta	9831241956 7685835234	amit@dagagroup.com mpandit@dagagroup.com
		M/s R K Wire Products Ltd, Kolkata	Unit No-VII, 15th Floor,Tower-I, PS Srijan Corporate Park,Plot No G-2, Block-EP & GP, Sector-V, Salt Lake City, Kolkata - 700 091	Mr. Indrajeet Banerjee	9123380881	ib@rkwire.com info@rkwire.com
39	GI Pipe	M/s Tata Iron & Steel Ltd,Jamshedpur	4, Armoury Road, Bistupur, Jamshedpur, Jharkhand, India-831001			ibmd.marketingcomm@tatasteel.com
		M/s Jindal Steel & Power Ltd,Bhubaneswar	Plot no.3,Forest Park,Bhubaneswar-751009	Mr.Mehul Aggarwal	9812063000 8288063000	Mehul.aggarwal@jindalsteel.com
40	GI Bolts & Nuts	M/s Garg Fasteners,Ludhiana	Street No.5,Saheed Bhagat Singh Colony,(Near Swaran Cinema),Sherpur,Ludhiana-141010			garg@gargfasteners.com
		M/s NEXO Industries Pvt Ltd,Ludhiana	Village Mangarh, Machhiwara Road, Kohara Ludhiana-141 112 (INDIA).		9814022767 9814222767	info@nexoindia.com
		M/s G.K. Winding Wires Ltd,Noida	B-20, UPSIDC Industrial Area, Site C, Surajpur, Greater Noida, (U.P)- 201306		918744005143	bd@gkwinning.com
		M/s Maheswari Fasteners & Bright Pvt. Ltd.,Hyderabad	Plot No. - 152 & 154, IDA Medchal, Medchal, Hyderabad, Telangana - 501401, India		9246887753 9246810800	maheswarifasteners@gmail.com mktg.mfb@gmail.com
		M/s Agarwal Fasteners Pvt Ltd,Maharashtra	Plot No 11, Manohar Palghar Road, Chahade Village, Saijanpada, Palghar (E), Thane Dist - 401404 , Maharashtra, India	Mr. Arish Malvi	7720010545	marketing@aplhome.com
		M/s Techman India Ltd, Chandigarh	Plot No. 163, Phase 2, Industrial Area, Chandigarh-160002, India	Mr. A.L Aggarwal	08043051633	
		M/s Millenium structurals (India ) Ltd, Indore	Indore Trade Centre, 3/2, South Tukoganj, Indore-452002, Madhya Pradesh, India	Mr.Datta Hase	09317878877	
		M/s Strelling Bolts Pvt. Ltd, Kolkata	1 ,Bonfield Lane, Kolkata, West Bengal		9674161869	corporate@sterlingbolts.net
		M/s Pankaj International Ltd, Ludhiana	B-40/III, Phase V, Focal Point, Ludhiana-141010 (INDIA)		09463400401	sales@pankajinternational.com quality@pankajinternational.com madhur@pankajinternational.com
		M/s Ravi Engineers Ltd, Punjab	Plot No.179-183, Focal Point, Industrial Area, Amritsar ,Punjab-143001		9814050801 9814111804	satyam@raviengineers.net
		M/s Precision Industrial Fasteners, Ludhiana	Hara Industrial Estate, Near Sukhmani Kanda, Sua Road, Indl. Area-C, Ludhiana-141014, Punjab, INDIA	Mr.Vekkas Banssal Mr. Sanjay Bansal	9878500193 9878400193	vekkas@pafnuts.com sanjay@pafnuts.com vekkasbanssal@yahoo.in
		M/s Deepak Fasteners Ltd, Ludhiana	4th Floor, First Mall, Mall Road,Ludhiana - 141001 Punjab, India			sales@deepakfasteners.com
		M/s Fit Right Nut and Bolts Pvt Ltd.,Maharashtra	E-27,Additional Ambermath Industrial Area,Anand Nagar,MIDC,Ambarnath,Maharashtra-421506			sales@fitright.co.in
		M/s Bharat Industries, Gujarat	8-A National Highway, Mahendranagar Morbi - 363 642 , Gujarat (India)		98253 34342	info@bharatindustries.co.in
		Karamtara Engineering Pvt Ltd.,Maharashtra	Plot No. A-12, MIDC, Tarapur, District : Palghar,401506, INDIA	Mr.D B Subramanian (Assistant Manager)	02240710000	Sales.Fasteners@karamtara.com
		M/s Bolt Master India Pvt Ltd, Maharashtra	D- 1, Laghu Udyog Kendra, I.B. Patel Road Goregaon East, Mumbai- 400063, Maharashtra, India	Mr.Chirag Gambhira (Business Development Director)	09819057175	
M/s J.C. Fasteners Ltd, Haryana	Rohtak, Haryana, India	Mr.Siddhaarth Jain	98966671140	siddhaarthji@gmail.com		
M/s Bharati Overseas Ltd, Ludhiana	B-29/6 & 12, N.P.C Transport Lane, Sherpur Chowk, G.T. Road, Ludhiana - 141003 (INDIA)	Mr. Anil Bharti Mr. Sanjeev Bharti	99151 99884 99156 03388	info@bhartioverseas.org admin@bhartioverseas.co.in		



TPCODL		APPROVED MANUFACTURER-DISTRIBUTOR LIST OF TPCODL ( For New Connection work only) Updated Upto 10.01.2024				Valid Till : 31.01.2024
Sr. No	Description of Material/ Equipment	Manufacturer Name	Contact Address	Contact Person	Contact No.	Email ID
	GI Bolts & Nuts	M/s Remax India Fasteners Industries Ltd,Ludhiana	D-62, Focal Point Rd, Phase V, Focal Point, Ludhiana, Punjab -141010	Mr.S. Parminder Singh Mr.S. Manpreet Singh	94170 57262 9501017262	info@remaxbolts.com export@remaxbolts.com
		M/s Forex Fasteners, Ludhiana	Forex Estate, Dehlon Road, Vill. Dhrou, Sahnewal, District Ludhiana-141120, Punjab, India		9855037567	customercare@forex.co.in
		M/s A V Forgings,Punjab	230, Industrial Area, Phase- IX Mohali(Punjab), India	Mr.Vikas Gupta Mr.Anil Goyal	09815354249 09814115092	sales@avforgings.com
		M/s Anshika Fasteners,Maharashtra	216/217 Wanaongri, MIDC Hingna Road, Nagpur, India 440016		9765550134	info@anshikafasteners.com
		M/s Durafast Automatives Pvt Ltd, Andhra Pradesh	Plot No.31, Block-E,Autonagar, Visakhapatnam,Andhra Pradesh,India-530012			rudra.sahoo@aster.in
		M/s Paramhari Engineers Pvt Ltd,Maharashtra	Plot No 6A,Vijay Nagar,Nagpur,Maharashtra-440013			claw@jsuberoi.com
		M/s Turbo Industries Pvt Ltd,Ludhiana	Industrial Area C, Dhandari Kalan, Surjit Cinema Road, Ludhiana-141010, Punjab, India	Mr.Sanjeev Kumar (HOD Design & Works)	08048935178	
		M/s Roshan Impex,Ludhiana	Plot No. 30-31, Street No. 3, Oswal Agro Plot, GT Road, Ludhiana-141003 Punjab-INDIA	Mr. Narinder Singh (Managing Director)	9876036600	md@roshanimpex.in
		M/s Isitva (Fasteners) Pvt Ltd,Hyderabad	Survey No.58, Keesara Road,Nagaram Village,Hyderabad-501 301		040-27127766	info@isitva.in
41	Steel Structure	M/s SAIL India Ltd,Rourkela	SAIL, Rourkela Steel Plant, Rourkela, 769011	Mr.Subhransu Mohanty	9437074007	smohanty@sail.in
		M/s Rashtriya Ispat Nigam Ltd.,Vizag	Visakhapatnam Steel Plant, Visakhapatnam - 530031,Andhra Pradesh	Mr. Ashutosh Verma	9907140015	
		M/s Jindal Steel & Power Ltd,Bhubaneswar	Plot no.3,Forest Park,Bhubaneswar-751009	Mr.Mehul Aggarwal	9812063000 8288063000	Mehul.aggarwal@jindalsteel.com
42	GI Earth Wire	M/s Aarti Steels Ltd.,Cuttack	Ghantikhil ,Mahakalbasta,Athgarh,Cuttack (Orissa)		91-671-7161000	info@aartisteelsltd.com
		M/s Kritika Wires (P) Ltd.,Kolkata	No.1A, Bonfield Lane, Bara bazaar,Mezanine Floor,Caning Street,Kolkata, West Bengal, 700001		3322429581	
		M/s UIC Udyog Limited,Kolkata	Anandlok, Block- A, 1st Floor, 227, A.J.C. Bose Road, Kolkata - 700020,West Bengal, India.			info@uicwires.com, sales@uicwires.com
		M/s. Gupta power Infrastructure Ltd,Khurda	F/9, IID Centre,Khurda, Odisha-752054	Mr.Mridul Tyagi Mr.Sandeep Kumar Mr. Debabrata Parida	9821762282 8130388990 9937937659	mridul.tyagi@guptapower.com sandeep@guptapower.com debabrata.parida@guptapower.com
		M/s G.K Winding Wires Ltd,Noida	B-20, UPSIDC Industrial Area, Site C, Surajpur Greater Noida, (U.P) 201306 (India)		8744005143	bd@gkwinning.com
		M/s Balaji Wires Pvt Ltd,Daman	Plot 51 & 52, Bharat Industrial Estate, Bhimpore, Daman 396210		9909952812	hr@balajiwires.in, costing@balajiwires.in
		M/s R K Wire Products Ltd, Kolkata	Unit No-VII, 15th Floor,Tower-1, PS Srijan Corporate Park,Plot No G-2, Block-EP & GP, Sector-V, Salt Lake City, Kolkata - 700 091	Mr. Indrajeet Banerjee	9123380881	ib@rkwire.com info@rkwire.com
		M/s Bajrang Wire Products(India) Pvt Ltd, Jaipur	E - 762(A), Road No. 9F - 1, Vishwakarma Industrial Area, Jaipur - 302 013, INDIA	Mr.Gajendra Maheshwari Mr.Ashish Maheshwari	9414050162 9414052722	enquiry@bajranggroup.com
		M/s Kataria Wires Pvt Ltd,Madhya Pradesh	Kataria Industries Pvt. Ltd.34-38 & 44 Industrial Area, Ratlam - 457001 (MP) - INDIA		9981828377	info@katarigroup.co.in sales@katarigroup.co.in marketing@katarigroup.co.in
		M/s Bharat Wire Ropes Ltd,Mumbai	A - 701, Trade World Building, Kamala Mills, Senapati Bapat Marg, Lower Parel (W), Mumbai			info@bharatwireropes.com
		M/s Ratlam Wires Pvt Ltd,Madhya Pradesh	Plot No. 3, Industrial Estate., Ratlam-457001, Madhya Pradesh, India	Mr.Jeevan Singh Dhala (Managing Director)	08048987734	
		M/s Tata Iron & Steel Ltd,Jamshedpur	4, Armoury Road, Bistupur,Jamshedpur,Jharkhand			ibmd.marketingcomm@tatasteel.com
		M/s Usha Martin Industries Ltd,Kolkata	2A, Shakespeare Sarani,'Mangal Kalash',Kolkata			marketing-east@ushamartin.com
		M/s Jainco Transmission Ltd, Howrah	Jalan Complex, Gate No. 1, Lane No. 7, NH-6, Howrah, West Bengal	Mr.Pratul Ghosh	9831607956	engg@jainco.net

TPCODL		APPROVED MANUFACTURER-DISTRIBUTOR LIST OF TPCODL ( For New Connection work only) Updated Upto 10.01.2024				Valid Till : 31.01.2024
Sr. No	Description of Material/ Equipment	Manufacturer Name	Contact Address	Contact Person	Contact No.	Email ID
		M/s Ramsarup Industrial Corporation Ltd,Kolkata	7C, Kiran Shankar Roy Road, Hastings Chamber, 1st & 2nd Floor,Kolkata - 700 001			ramsarup@cal2.vsnl.net.in wire@ramsarup.com infra@ramsarup.com
		M/s Manohar Lal Hira Lal Ltd,Ghaziabad	28th KM Stone , Delhi Meerut Road,Duhai,Sainthli, Muradnagar,Ghaziabad ,(U.P) -201206			mhwire@mhwire.com mktg@mhwire.com
43	LT ABC Accessories, IPC (Insulated Piercing connector, Suspension, Dead end etc.)	M/s KSE Electricals,Howrah	3rd Main road,NH-6,Begri,Howrah,West Bengal	Mr.Ashis.K Palit	9830547600	mktg@kse.in
		M/s Jainco Transmission Ltd, Howrah	Jalan Complex, Gate No. 1, Lane No. 7, NH-6, Howrah, West Bengal	Mr.Pratul Ghosh	9831607956	engg@jainco.net
			<b>Authorized Distributors:</b> <b>1. M/s Samal Industries, Khurda</b> Plot No C/10 and 9/1 IID centre Industrial Estate Khurda	Mr. Prakash Samal	9437231336	samalindustries1234@gmail.com
		M/s Raychem RPG Pvt Ltd.,Gujurat	Kanjari,Jyoti Compound,Near Halol GIDC,Panchmahal,Gujarat	Mr.Rahul Biswas Mr.Mehul Patel	9771427299 9724304622	rahul_biswas@raychemrpg.com
		M/s SICAME India Connectors Pvt Ltd,Tamilnadu	473/1(96),Sirkundram Village,Chengalpet Taluk,Kanchipuram,Sirkundram, Tamilnadu-603108	Mr.Mahesh Kumar	9818156021	mahesh.gurjar@sicame.in
		M/s 3M Electro & Communication India Pvt Ltd,Pune	145,Mumbai-Pune Road,Pimpri,Pune,Maharashtra	Mr.Sujit Kumar Nayak Mr.Abhijit Bhagwat	98306 62725 9850667259	arbhagwat@mmm.com sknayak@mmm.com
44	Fire Fighting Equipment	MINIMAX ,Gujurat	Gunnebo India Private Ltd.Plot No. 1302-1306, GIDC Industrial Estate,Panchmahal, Halol - 389350, Gujrat,India			info@minimax.co.in
		M/s Kanadia Fyr Fyter Pvt Ltd,Gujurat	A-110, Kanara Business Centre, B/H. Everest Garden, Apartment Laxmi Nagar, Ghatkopar East, Sihar, Bhavnagar-334240, Gujarat, India	Mr.Akash Bhatt	09376717299	
		M/s Ceasefire Industries Pvt Ltd,Noida	Plot No 4, 2nd Floor, Noida-Greater Noida Expy, Sector 135, Noida, Uttar Pradesh- 201304		9540 666 666	response@ceasefire.in
		M/s Aska Equipments Pvt Ltd,New Delhi	R-482,New Rajendra Nagar,Gangaram Hospital Square,Shankar Road,New Delhi-110060			sales@askagroup.com
		M/s Nitin Fire Protection Industries Ltd,Mumbai	501 Delta,Technology Street,Hiranandani Powai,Mumbai,INDIA : 400076			nitinfire@vsnl.com
		M/s Safex Fire Services Ltd,Mumbai	A-202, Dhanraj Industrial Estate, Dhanraj Mill Compound, S. J. Road,Lower Parel (w), MUMBAI 400 013 INDIA			tejas@safexfire.com
		M/s The Zenith Engineers Ltd,West Bengal	Karbala , Sonarpur, Vivekanand College, Narendrapur, Kolkata-700103, West Bengal, India	Mr. Subir Ghosh	08068441113 Dial(425) connected	
45	Bird Cap	M/s.3M Electro & Communication India Pvt Ltd,Pune	145,Mumbai-Pune Road,Pimpri,Pune,Maharashtra	Mr.Sujit Kumar Nayak Mr.Abhijit Bhagwat	9830662725 9850667259	arbhagwat@mmm.com sknayak@mmm.com
		M/s Raychem RPG Pvt Ltd.,Gujurat	Kanjari,Jyoti Compound,Nr Halol GIDC,Panchmahal,Gujarat	Mr.Rahul Biswas Mr.Mehul Patel	9771427299 9724304622	rahul_biswas@raychemrpg.com
46	Bird Guard	M/s Asian Loto Corporation Ltd, Haryana	C-3,1st Floor,Arya Samaj Road,Nehru Ground,N.I.T,Faridabad-121001	Mr.Dipak Arora	9811320275 9599057159	asianloto@asianlotocorporation.com sales@asianloto.com
		M/s Mangal Enterprises Pvt Ltd, Delhi	1743/46, 1st Floor,Electrical Market,Bhagirath Palace,Chandini Chowk,Delhi-110006	Mr.Bhuwan Pandey	8800702333	mangalenterprises2011@gmail.com
		M/s Namdhari Industrial Traders Pvt Ltd,Ludhiana	Latton Dana,Chandigarh Road,Ludhiana-141003	Mr.Gurjeet Singh	9814100398 9592000398	namdhari_ind_traders@yahoo.com sales@namdhariindtraders.com
		M/s Rahul Powertech Engineers Pvt Ltd,Rajasthan	A-807,Phase-2,Industrial Area,Bhilwadi,Alwar,Rajasthan	Mr.Yogendra Jain	9350863924 9810437369	
		M/s Yogeyata Electric,Delhi	361,Rohini,Sector-14,Aggrawal Plaza,Shahabad,Delhi-110033	Mr.Yogesh Singla	8048372221	