

CORRIGENDUM-1

Ref: TPCODL/P&S/117/2020-21/Corrigendum/001

Dated: 29th Oct 2020

Subject: Addition/Modification to Technical Specification of Tender number TPCODL/P&S/117/2020-21

Reference Document- Our Tender number TPCODL/P&S/117/2020-21 for Rate contract for Supply, Installation, Testing and Commissioning of High Mast Lights at stores of TPCODL.

With reference to above the bidder are intimated to note the following and find Replies to bid queries:

I. Extension of due date and time of bid submission/opening of Technical bids and EMD:

Tender No.	Work Description	Existing Entry	May be read as
TPCODL/P&S/117/2020-21	Rate Contract for Supply, Installation, Testing and Commissioning of High Mast Lights at stores of TPCODL	<p>a: Last date and time of Payment of Tender Fee 28.10.2020 1500 Hours</p> <p>b: Due date and time of bid submission /Date & Time of opening technical bids and EMD) 10.11.2020 1500 Hours</p>	<p>a: Last date and time of Payment of Tender Fee 05.11.2020 15:00 Hours</p> <p>b: Due date and time of bid submission /Date & Time of opening technical bids and EMD) 16.11.2020 1500 Hours</p>

II. Addition/Modification to Technical Specification as Annexure-A

Note:

- Those new bidders who are interested to participated in our above tender, they are requested to download the above tender from our website and submit their bids along with tender fee, and all supporting documents as per Corrigendum-1 and revised time schedule
- Only new bidders who have not participated earlier in above tender are allowed to submit their pre-bid queries (if any) by e-mail only latest by Dt.06.11.2020 15:00 Hrs
- All other terms and conditions of the above tender will remain same

By Order

Chief-Procurement & Store, TPCODL

ANNEXURE-A

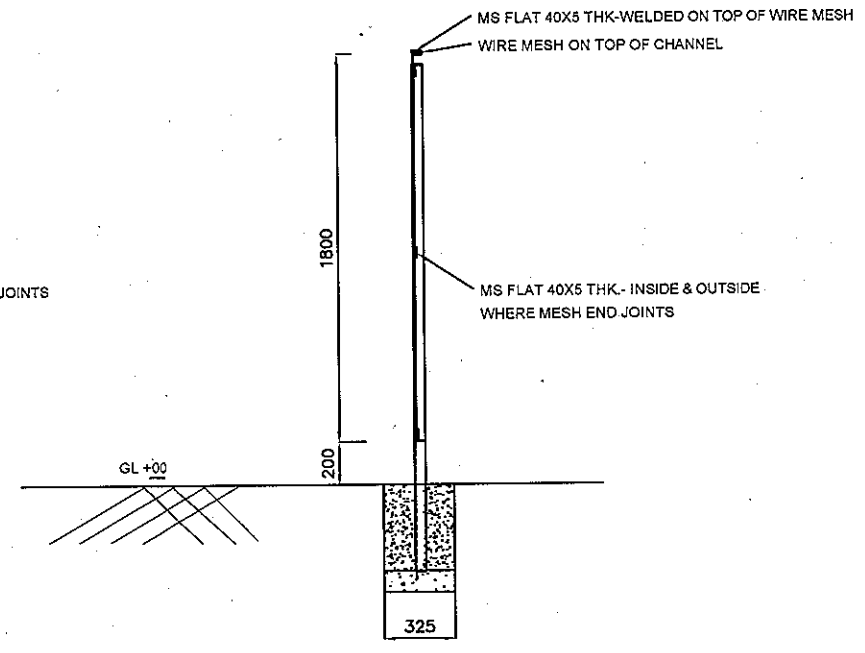
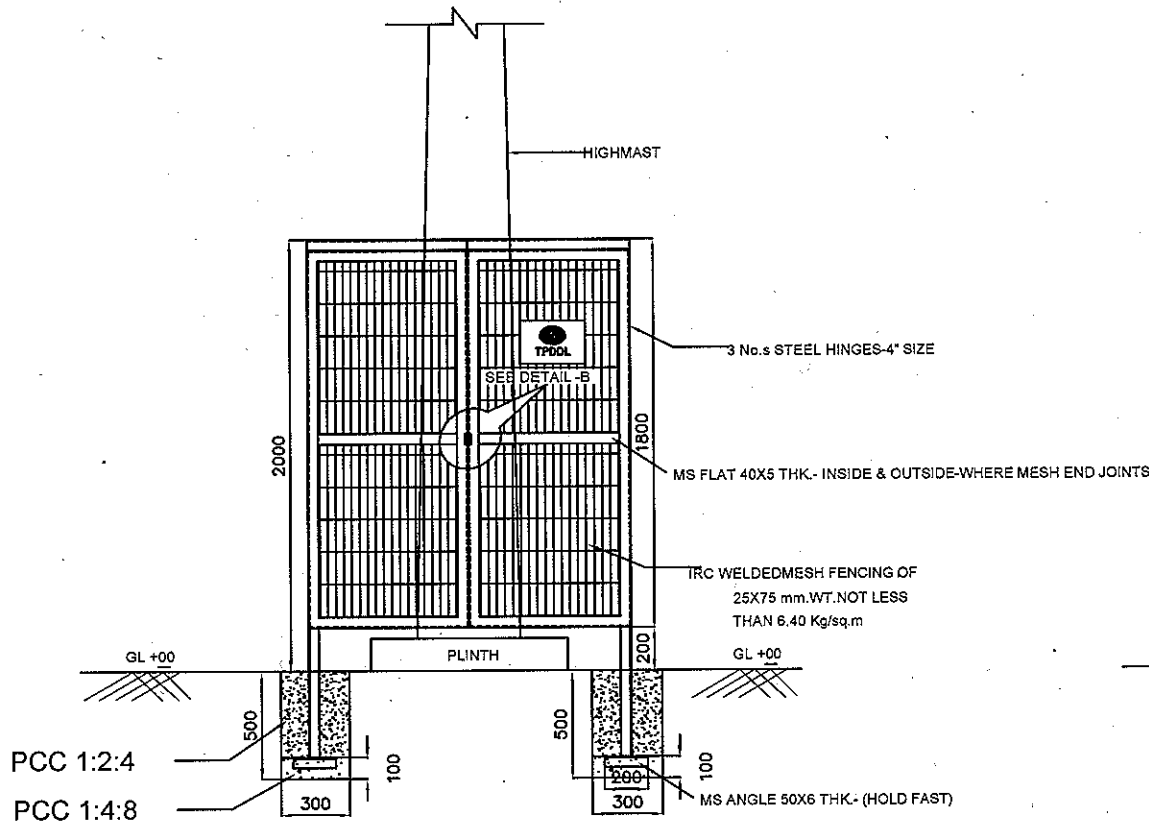

ELEVATION - A - A'

SECTIONAL ELEVATION - BB'

FDT. 300X300X500

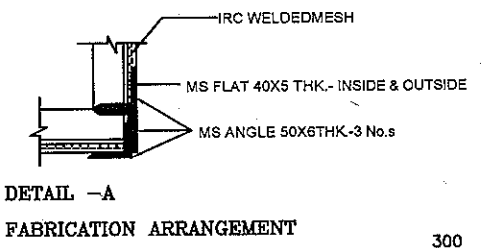
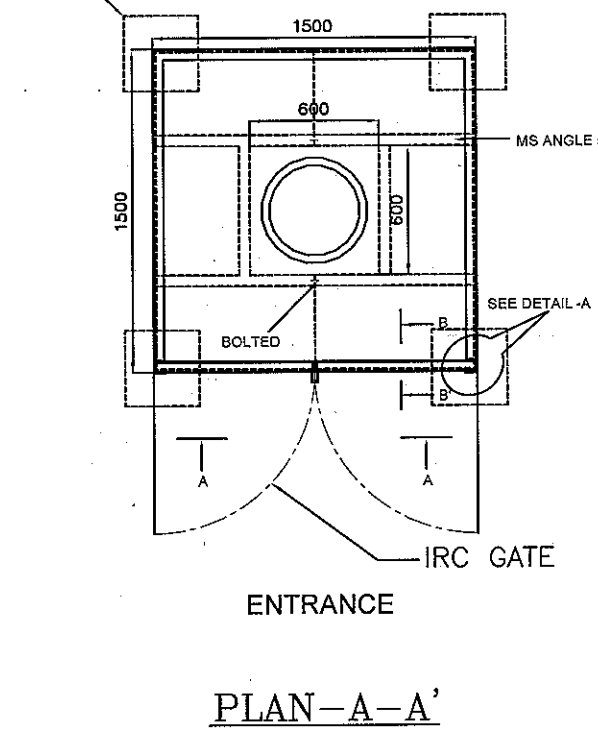

DETAIL - A
FABRICATION ARRANGEMENT

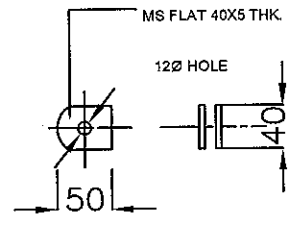

DETAIL - B
LOCKING ARRANGEMENT

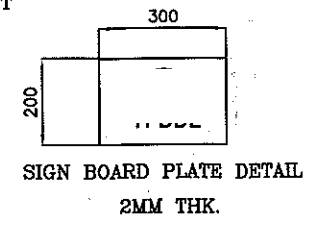

LEGEND:-

NOTE:-

All dimensions are in mm and the drawing is in not in scale

REFERENCES:-

REVISION STATUS:-						
DATE	REV. NO.	REVISION	DGN.	REV.	APPD.	ISSUED.
	2					
	1					
12.12.12	0	issued for construction purpose				

PROJECT:- STATION LIGHTING/STREET LIGHTING

DESIGN PS TITLE:-
DRAWN RKP
CHECKED PS
FENCING FOR HIGHMAST

APPD.	JKS	SHEET	DRAWING NO.	REV.
SCALE	NTS	1 OF 1	TPD-S-121-D-039	0